

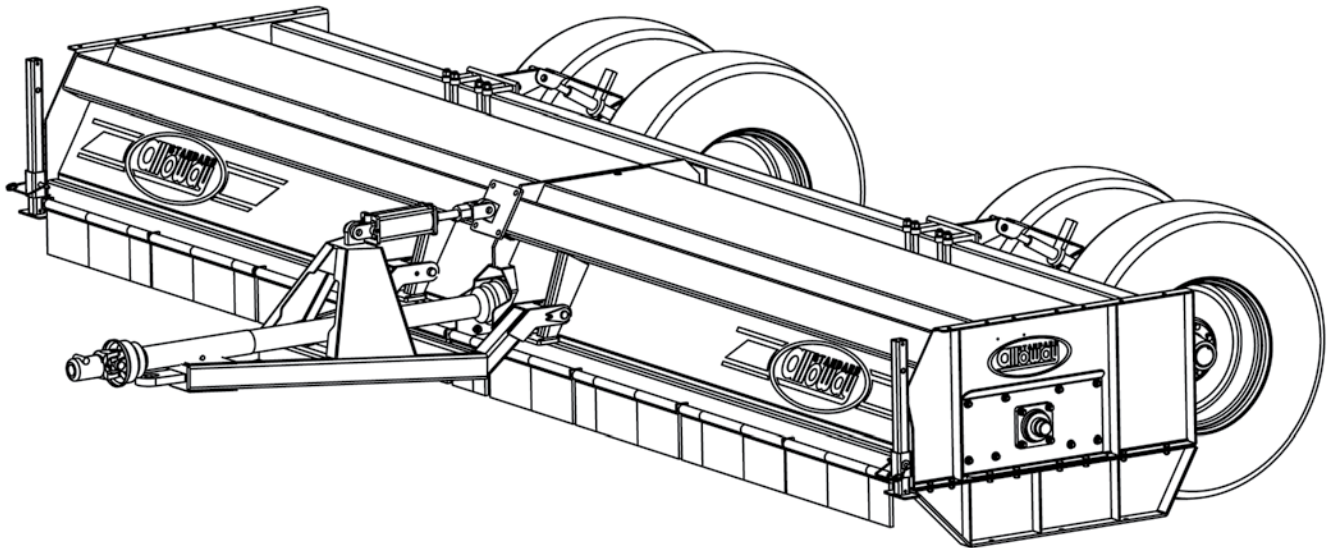

2007 - 2008

CENTER DRIVE SHREDDER



OPERATOR'S MANUAL

TO THE DEALER:

Assembly and proper installation of this product is the responsibility of the Alloway dealer. Read manual instructions and safety rules. Make sure all items on the Dealer's Pre-Delivery and Delivery Check Lists in the Operator's Manual are completed before releasing equipment to the owner.

The dealer must complete the Warranty Registration included in this manual. Both dealer and customer must sign the registration which certifies that all Dealer Check List items have been completed. The dealer is to return the prepaid postage portion to Alloway, give one copy to the customer, and retain one copy. **Note: Warranty credit is subject to this form being completed and returned.**

TO THE OWNER:

Read this manual before operating your Alloway equipment. The information presented will prepare you to do a better and safer job. Keep this manual handy for ready reference. Require all operators to read this manual carefully and become acquainted with all the adjustment and operating procedures before attempting to operate. Replacement manuals can be obtained from your dealer.

The equipment you have purchased has been carefully engineered and manufactured to provide dependable and satisfactory use. Like all mechanical products, it will require cleaning and upkeep. Lubricate the unit as specified. Observe all safety information in this manual and safety decals on the equipment.

For service, your authorized Alloway dealer has trained mechanics, genuine Alloway service parts, and the necessary tools and equipment to handle all your needs.

Use only genuine Alloway service parts. Substitute parts will void the warranty and may not meet standards required for safe and satisfactory operation. Record the model number and serial number of your equipment in the spaces provided:

Model: _____ **Date of Purchase** _____

Serial Number: (see Safety Decal section for location) _____

Provide this information to your dealer to obtain correct repair parts.

Throughout this manual, the term **IMPORTANT** is used to indicate that failure to observe can cause damage to equipment. The terms **CAUTION**, **WARNING** and **DANGER** are used in conjunction with the Safety-Alert Symbol, (a triangle with an exclamation mark), to indicate the degree of hazard for items of personal safety.



This Safety-Alert Symbol indicates a hazard and means **ATTENTION! BECOME ALERT! YOUR SAFETY IS INVOLVED!**



Indicates an imminently hazardous situation that, if not avoided, will result in death or serious injury.



Indicates a potentially hazardous situation that, if not avoided, could result in death or serious injury, and includes hazards that are exposed when guards are removed



Indicates a potentially hazardous situation that, if not avoided, may result in minor or moderate injury.

IMPORTANT

Indicates that failure to observe can cause damage to equipment.

NOTE

Indicates helpful information.

TABLE OF CONTENTS

INTRODUCTION	Inside Front Cover
GENERAL INFORMATION	1
SPECIFICATIONS	2
SAFETY RULES	3-6
SAFETY DECALS	8-9
OPERATOR SIGN-OFF RECORD	10
OPERATION	11
FIELD OPERATION.....	17
ADDITIONAL EQUIPMENT	24
SHREDDER STORAGE	25
SERVICE & MAINTENANCE	26
TROUBLE SHOOTING	37
CONTOUR FLAIL PATTERN WORKSHEETS	38
ASSEMBLY	40
INDEX TO PARTS LISTS	47
BOLT TORQUE CHART	66
BOLT SIZE CHART & ABBREVIATIONS	67
NUMERICAL INDEX	68
INDEX	70
REPLACEMENT PARTS WARRANTY	72
PRODUCT WARRANTY.....	Inside Back Cover

GENERAL INFORMATION

The purpose of this manual is to assist you in operating and maintaining your Center Drive Shredder. Read it carefully. It furnishes information and instructions that will help you achieve years of dependable performance. These instructions have been compiled from extensive field experience and engineering data. Some information may be general in nature due to unknown and varying operating conditions. However, through experience and these instructions, you should be able to develop procedures suitable to your particular situation.

The illustrations and data used in this manual were current at the time of printing, but due to possible inline production changes, your machine may vary

Slightly in detail. We reserve the right to redesign and change the machines as may be necessary without notification.

WARNING

■ **Some illustrations in this manual show the Center Drive Shredder with safety shields removed to provide a better view. The Center Drive Shredder should never be operated with any safety shielding removed.**

Throughout this manual, references are made to right and left direction. These are determined by standing behind the equipment facing the direction of forward travel.

SPECIFICATIONS

Maximum Outside Body Width:

12'	149 in. (3.8m)
15'	189 in. (4.9m)
18'	221 in. (5.6m)
20'	253 in. (6.4m)
22'	277 in. (7.0m)
25'	309 in. (7.8m)
27'	333 in. (8.4m)
30'	369 in. (9.3m)

Cutting Height 3 - 18 in. (7.62 cm to 45.7 cm)

Width of Cut

12'	142 in. (3.6m)
15'	182 in. (4.6m)
18'	214 in. (5.4m)
20'	246 in. (6.2m)
22'	270 in. (6.8m)
25'	302 in. (7.6m)
27'	326 in. (8.3m)
30'	362 in. (9.2m)

Knives: Cups "L"

Number on 12'	64	128
Number on 15'	84	168
Number on 18'	100	200
Number on 20'	116	232
Number on 22'	128	256
Number on 25'	136	272
Number on 27'	156	312
Number on 30'		

Recommended Tire Size:..... Traction Tires 7.50 x 15 or 12.4 x 24

Tire Inflation Pressure: 25 psi

Rotor: Speed 1500 RPM dynamically balanced

Drive: PTO 1000 RPM

Weight of Shredder (approximate):

12'	2800 lbs. (1270 kg)
15'	3100 lbs. (1406 kg)
18'	3400 lbs. (1542 kg)
20'	3700 lbs. (1678 kg)
22'	4000 lbs. (1814 kg)
25'	4770 lbs. (2163 kg)
27'	5100 lbs. (2313 kg)
30'	5900 lbs. (2676 kg)



SAFETY RULES

ATTENTION! BECOME ALERT! YOUR SAFETY IS INVOLVED!



Safety is a primary concern in the design and manufacture of our products. Unfortunately, our efforts to provide safe equipment can be wiped out by a single careless act of an operator.

In addition to the design and configuration of equipment, hazard control and accident prevention are dependent upon the awareness, concern, prudence and proper training of personnel involved in the operation, transport, maintenance and storage of equipment.

It has been said *"The best safety device is an informed, careful operator."* We ask you to be that kind of an operator.

The designed and tested safety of this equipment depends on it being operated within the limitations as explained in this manual.

TRAINING

- **Safety instructions are important! Read all attachment and power unit manuals; follow all safety rules and safety decal information. (Replacement manuals are available from dealer). Failure to follow instructions or safety rules can result in serious injury or death.**
- **If you do not understand any part of this manual and need assistance, see your dealer.**
- **Know your controls and how to stop engine and attachment quickly in an emergency.**
- **Operators must be instructed in and be capable of the safe operation of the equipment, its attachments and all controls. Do not allow anyone to operate this equipment without proper instructions.**
- **Keep hands and body away from pressurized lines. Use paper or cardboard, not body parts to check for leaks. Wear safety goggles. Hydraulic fluid under pressure can easily penetrate skin and will cause serious injury or death.**
- **Make sure that all operating and service personnel know that in the event hydraulic fluid penetrates skin, it must be surgically removed as soon as possible by a doctor familiar with this form of injury, or gangrene, serious injury or death will result. CONTACT A PHYSICIAN IMMEDIATELY IF FLUID ENTERS SKIN OR EYES. DO NOT DELAY.**
- **Never allow children or untrained persons to operate equipment.**

PREPARATION

- **Check that all hardware is tight and properly installed. Always tighten to torque chart specifications unless instructed otherwise in this manual.**
- **Air in hydraulic systems can cause erratic operation and allows loads or equipment components to drop unexpectedly. Before operating or allowing anyone to approach the equipment, purge any air in the system by operating all hydraulic functions several times after connecting equipment, connecting hoses, or doing any hydraulic maintenance.**
- **Make sure all hydraulic hoses, fittings and valves are in good condition and not leaking before starting power unit or using equipment. Check and route hoses carefully to prevent damage. Hoses must not be twisted, bent sharply, kinked, frayed, pinched, or come into contact with any moving parts. Operate moveable components through full operational range to check clearances. Replace any damaged hoses immediately.**
- **Always wear relatively tight and belted clothing to avoid entanglement in moving parts. Wear sturdy, rough-soled work shoes and protective equipment for eyes, hair, hands, hearing and head; and respirator or filter mask where appropriate.**
- **Ensure implement is properly attached, adjusted and in good operating condition.**
- **Make sure spring-activated locking pin or collar slides freely and is seated firmly in tractor PTO spline groove.**
- **Before starting power unit, check all equipment driveline guards for damage and make sure they rotate freely on all drivelines. Replace any damaged guards. If guards do not rotate freely on drivelines, repair and replace bearings before operating.**
- **Power unit must be equipped with ROPS or ROPS CAB and seat belt. Keep seat belt securely fastened. Falling off power unit can result in death from being run over or crushed. Keep foldable ROPS systems in "locked up" position at all times.**
- **Connect PTO driveline directly to power unit PTO shaft. Never use adapter sleeves or adapter shafts. Adapters can cause driveline failures due to incorrect spline or incorrect operating length and can result in personal injury or death.**

SAFETY RULES



ATTENTION! BECOME ALERT! YOUR SAFETY IS INVOLVED!



- Inspect rubber flaps and swing rod before each use. Replace if damaged or missing. Flaps must pivot and hang freely so there are no gaps. Do not put equipment into service until repaired.
- Remove accumulated debris from this equipment, tractor and engine to avoid fire hazard.
- Ensure all safety decals are installed. Replace if damaged. (See Safety Decals section for location.)
- Ensure shields and guards are properly installed and in good condition. Replace if damaged.
- A minimum 20% of tractor and equipment weight must be on tractor front wheels when attachments are in transport position. Without this weight, tractor could tip over, causing personal injury or death. The weight may be attained with a loader, front wheel weights, ballast in tires or front tractor weights. When attaining the minimum 20% weight on the front wheels, you must not exceed the Roll Over Protection Structure (ROPS) weight certification. Weigh the tractor and equipment. Do not estimate.
- Make sure hydraulic hoses and cylinders are fully purged of air before operating. Keep all persons away and fill the system by raising and lowering all functions several times. Air in the system can allow components to fall unexpectedly.
- Inspect and clear area of stones, branches, or other hard objects that might be thrown, causing injury or damage.

TRANSPORTING

- Power unit must be equipped with ROPS or ROPS cab and seat belt. Keep seat belt securely fastened. Falling off power unit can result in death from being run over or crushed. Keep foldable ROPS systems in "locked up" position at all times.
- Always sit in power unit seat when operating controls or starting engine. Securely fasten seat belt, place transmission in neutral, engage brake, and ensure all other controls are disengaged before starting power unit engine.
- A minimum 20% of tractor and equipment weight must be on the tractor front wheels when attachments are in transport position. Without this weight, tractor could tip over, causing personal injury or death.

The weight may be attained with a loader, front wheel weights, ballast in tires or front tractor weights. Weigh the tractor and equipment. Do not estimate.

- Always attach safety chain to tractor drawbar when transporting unit.
- Always raise unit and install transport locks before transporting. Leak down or failure of mechanical or hydraulic system can cause equipment to drop.
- Never exceed 20 MPH during transport. See the Speed vs. Weight Ratio Table in "Field Operation, Transporting the Unit" for proper tow vehicle to machine weight ratios.
- Watch for hidden hazards on the terrain.
- Always comply with all state and local lighting and marking requirements.
- Never allow riders on power unit or attachment.
- Do not operate PTO during transport.
- Look down and to the rear and make sure area is clear before operating in reverse.
- Do not operate or transport on steep slopes.
- Use extreme care and reduce ground speed on slopes and rough terrain.
- Do not operate or transport equipment while under the influence of alcohol or drugs.

OPERATION

- Equipment may be pictured with covers open for instructional purposes. Never operate equipment with covers open.
- Do not allow bystanders in the area when operating, attaching, removing, assembling, or servicing equipment.
- Do not allow anyone to stand between tractor and unit when backing up to unit.
- Never go underneath equipment (lowered to the ground or raised) unless it is properly blocked and secured. Never place any part of the body underneath equipment or between moveable parts even when the engine has been turned off. Hydraulic system leak down, hydraulic system failures, mechanical failures, or movement of control levers can cause equipment to drop or rotate unexpectedly and cause severe injury or death. Follow Operator's Manual instructions for working underneath and blocking requirements or have work done by a qualified dealer.

(Safety Rules continued on next page)

PN-50730198 (11/07)



SAFETY RULES

ATTENTION! BECOME ALERT! YOUR SAFETY IS INVOLVED!



(Safety Rules continued from previous page)

- Keep bystanders away from equipment.
- Do not operate or transport equipment while under the influence of alcohol or drugs.
- Operate only in daylight or good artificial light.
- Avoid contact with electrical wires.
- Keep hands, feet, hair, and clothing away from equipment while engine is running. Stay clear of all moving parts.
- Always comply with all state and local lighting and marking requirements.
- Never allow riders on power unit or attachment.
- Power unit must be equipped with ROPS or ROPS cab and seat belt. Keep seat belt securely fastened. Falling off power unit can result in death from being run over or crushed. Keep foldable ROPS systems in "locked up" position at all times.
- Always sit in power unit seat when operating controls or starting engine. Securely fasten seat belt, place transmission in neutral, engage brake, and ensure all other controls are disengaged before starting power unit engine.
- Operate tractor PTO at the RPM speed stated in "Specifications" section.
- Do not operate PTO during transport.
- Look down and to the rear and make sure area is clear before operating in reverse.
- Do not operate or transport on steep slopes.
- Do not stop, start, or change directions suddenly on slopes.
- Use extreme care and reduce ground speed on slopes and rough terrain.
- Watch for hidden hazards on the terrain during operation.
- Stop power unit and equipment immediately upon striking an obstruction. Turn off engine, remove key, inspect, and repair any damage before resuming operation.
- Never work on scalper attachment in the raised position. Lower scalpings to the ground and service each unit individually.
- Always raise scalper arms before going in reverse.

- Always connect safety chain from equipment to towing vehicle when transporting.
- **AVOID INJURY OR DEATH FROM POWER LINES:**
 - Stay away from power lines.
 - Electrocution can occur without direct contact.
 - Check clearances before raising implement.
 - Do not leave the operator's seat if any part of the tractor or implement contacts electric lines.
- Before servicing, adjusting, repairing or unplugging, stop tractor engine, place all controls in neutral, set park brake, remove ignition key, and wait for all moving parts to stop.
- Before working underneath a raised implement, read and follow all Operator's Manual instructions and safety rules. Implement must be attached to tractor. Lift cylinder locks must be installed and lift cylinders lowered against locks. Hydraulic system leak down, hydraulic system failures, or movement of control levers can cause equipment to drop unexpectedly and cause severe injury or death.

MAINTENANCE

- Before servicing, adjusting, repairing or unplugging, stop tractor engine, place all controls in neutral, set park brake, remove ignition key, and wait for all moving parts to stop.
- Before working underneath a raised implement, read and follow all Operator's Manual instructions and safety rules. Implement must be attached to tractor. Lift cylinder locks must be installed and lift cylinders lowered against locks. Hydraulic system leak down, hydraulic system failures, or movement of control levers can cause equipment to drop unexpectedly and cause severe injury or death.
- Service and maintenance work not covered in OWNER SERVICE must be done by a qualified dealership. Special skills, tools, and safety procedures may be required. Failure to follow these instructions can result in serious injury or death.
- Do not modify or alter or permit anyone else to modify or alter the equipment or any of its components in any way.
- Your dealer can supply original equipment hydraulic accessories and repair parts. Substitute parts may not meet original equipment specifications and may be dangerous.

SAFETY RULES



ATTENTION! BECOME ALERT! YOUR SAFETY IS INVOLVED!



- Always wear relatively tight and belted clothing to avoid entanglement in moving parts. Wear sturdy, rough-soled work shoes and protective equipment for eyes, hair, hands, hearing and head; and respirator or filter mask where appropriate.
- Do not allow other people in the area when operating, attaching, removing, assembling or servicing equipment.
- Never go underneath equipment lowered to the ground or raised, unless it is properly blocked and secured. Never place any part of the body underneath equipment or between moveable parts even when the engine has been turned off. Hydraulic system leak down, hydraulic system failures, mechanical failures or movement of control levers can cause equipment to drop or rotate unexpectedly and cause severe injury or death. Follow Operator's Manual instructions for working underneath and blocking requirements, or have work done by a qualified dealer.
- Ensure implement is properly attached, adjusted and in good operating condition.
- Never perform service or maintenance with engine running.
- Make sure hydraulic hoses and cylinders are fully purged of air before operating. Keep all persons away and fill the system by raising and lowering all functions several times. Air in the system can allow components to fall unexpectedly.

- Keep all persons away from operator control area while performing adjustments, service or maintenance.
- Make certain all movement of implement components has stopped before approaching for service.
- Do not handle blades with bare hands. Careless or improper handling may result in serious injury.
- Tighten all bolts, nuts and screws to torque chart specifications. Check that all cotter pins are installed securely to ensure equipment is in a safe condition before operating.
- Ensure all safety decals are installed. Replace if damaged. (See Safety Decals section for location.)
- Ensure shields and guards are properly installed and in good condition. Replace if damaged.
- Do not disconnect hydraulic lines until machine is securely blocked or placed in lowest position and system pressure is released by operating all valve control levers.

STORAGE

- Follow manual instructions for storage.
 - Keep children and bystanders away from storage area.
-

CHECK LISTS

PRE-DELIVERY CHECK LIST

(DEALER'S RESPONSIBILITY)

Inspect the equipment thoroughly after assembly to ensure it is set up properly before delivering it to the customer.

The following check lists are a reminder of points to inspect. Check off each item as it is found satisfactory or after proper adjustment is made.

- Check that all safety decals are installed and in good condition. Replace if damaged.
- Check that shields and guards are properly installed and in good condition. Replace if damaged.
- Check that PTO shaft is properly installed.
- Properly attach implement to tractor and make all necessary adjustments.
- Check all bolts to be sure they are tight.
- Check wheel bolts for proper torque.
- Check that all cotter pins and safety pins are properly installed. Replace if damaged.
- Check and grease all lubrication points as identified in "Service, lubrication information."
- Check the level of gearbox fluids before delivery. Service, if required, as specified in the "Service, lubrication information."
- Check that tractor hydraulic reservoir has been serviced and that hydraulic system and all functions have been operated through full cylinder stroke to purge air from system.
- After pressurizing and operating all Shredder functions, stop tractor and make sure there are no leaks in the hydraulic system. Follow all safety rules when checking for leaks.

DELIVERY CHECK LIST

(DEALER'S RESPONSIBILITY)

- Show customer how to make adjustments and select proper PTO speed.
- Show customer how to make adjustments.
- Instruct customer how to lubricate and explain importance of lubrication.
- Point out the safety decals. Explain their meaning and the need to keep them in place and in good condition. Emphasize the increased safety hazards when instructions are not followed.
- Present Operator's Manual and request that customer and all operators read it before operating equipment. Point out the manual safety rules, explain their meanings and emphasize the increased safety hazards that exist when safety rules are not followed.
- Show customer how to make sure driveline is properly installed and that spring-activated locking pin or collar slides freely and is seated in groove on tractor PTO shaft.
- Show customer the safe, proper procedures to be used when mounting, dismounting, and storing equipment.
- Explain to customer that when equipment is transported on a road or highway, safety devices should be used to give adequate warning to operators of other vehicles.
- Explain to customer that when equipment is transported on a road or highway, a Slow Moving Vehicle (SMV) sign should be used to provide adequate warning to operators of other vehicles.
- Explain to customer that when towing on a public road to comply with all state and local lighting/marketing laws and to use a safety tow chain.
- Make customer aware of optional equipment available so that customer can make proper choices as required.
- Point out all guards and shields. Explain their importance and the safety hazards that exist when not kept in place and in good condition.



SAFETY & INSTRUCTIONAL DECALS

ATTENTION! BECOME ALERT! YOUR SAFETY IS INVOLVED!

Replace Immediately If Damaged!

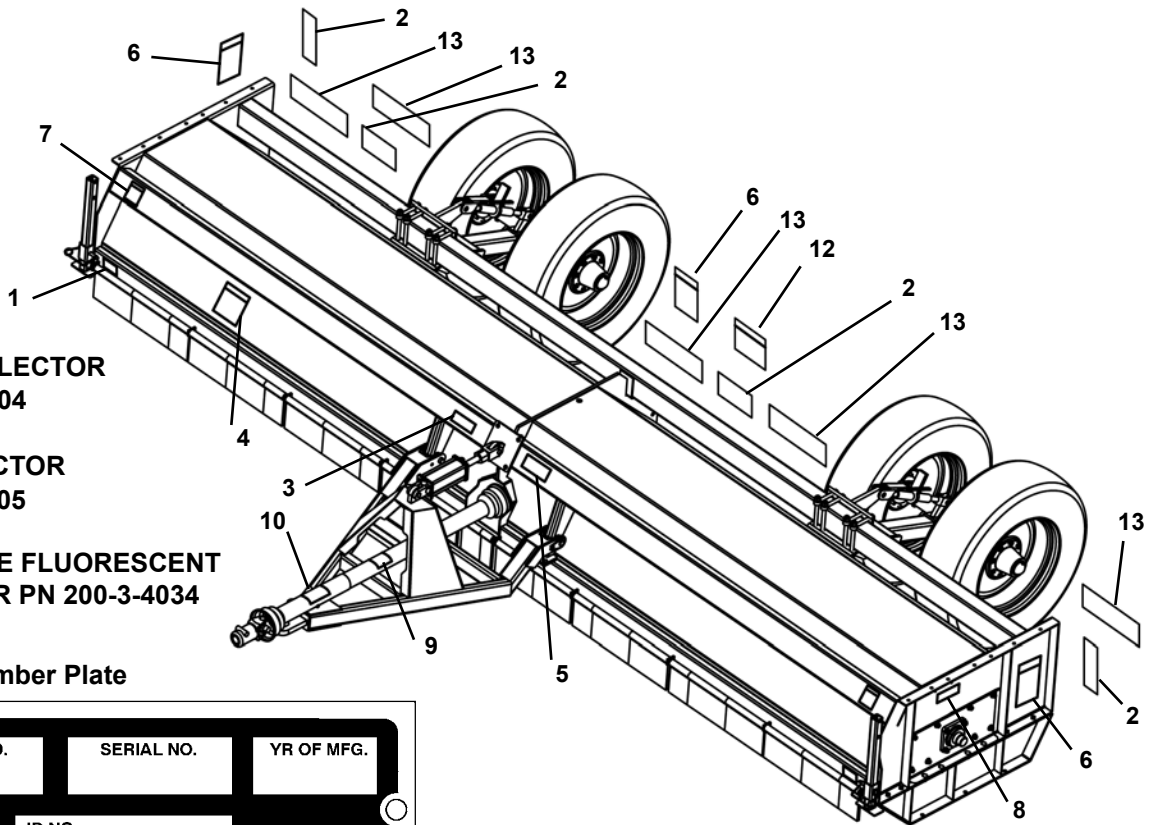

**1 - AMBER REFLECTOR
PN 200-3-4004**

**2 - RED REFLECTOR
PN 200-3-4005**

**13 - RED-ORANGE FLUORESCENT
REFLECTOR PN 200-3-4034**

3 - Serial Number Plate

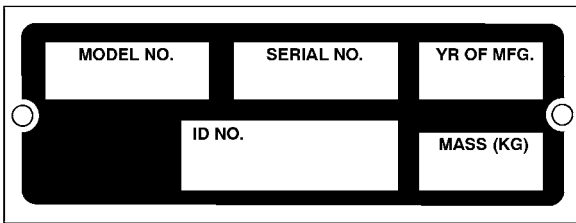

5 - PN 500-3-0978



6 - PN 500-3-0982

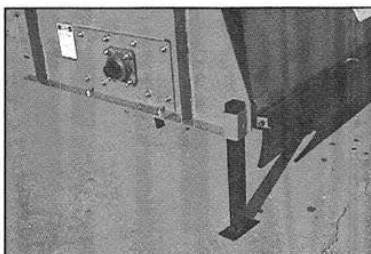

4 - PN 500-3-0977

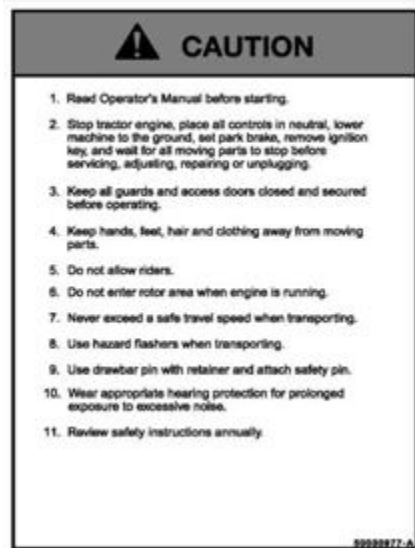

(Safety Decals continued on next page)

SAFETY & INSTRUCTIONAL DECALS
ATTENTION! BECOME ALERT! YOUR SAFETY IS INVOLVED!
 Replace Immediately If Damaged!

⚠ DANGER



**GUARD MISSING.
DO NOT OPERATE.**

⚠ DANGER



**GUARD MISSING.
DO NOT OPERATE.**

33347E

⚠ DANGER

9 - PN 33347

⚠ WARNING

MANUAL CONTAINER AND MANUAL ARE MISSING

- REPLACE AND READ BEFORE OPERATING.
- KEEP MANUAL CONTAINER AND MANUAL MOUNTED IN THIS LOCATION. (Available from dealer or call 1-877-275-8714.)

FAILURE TO FOLLOW MANUAL INSTRUCTIONS AND SAFETY RULES CAN RESULT IN SERIOUS INJURY OR DEATH. 506-3-0192

8 - PN 50630192

10 - PN 18864

⚠ DANGER



**ROTATING DRIVELINE
CONTACT CAN CAUSE DEATH
KEEP AWAY!**

DO NOT OPERATE WITHOUT-

- ALL DRIVELINE GUARDS, TRACTOR AND EQUIPMENT SHIELDS IN PLACE
- DRIVELINES SECURELY ATTACHED AT BOTH ENDS
- DRIVELINE GUARDS THAT TURN FREELY ON DRIVELINE

18864B

⚠ WARNING



THROWN OBJECT HAZARD

To prevent serious injury or death:

1. Stay away from the front of machine when operating.
2. Keep others away.
3. Keep deflectors in good condition when operating.

505-3-0314

7 - PN 50530314

⚠ WARNING



HIGH-PRESSURE FLUID HAZARD

To prevent serious injury or death:

1. Relieve pressure on system before repairing, adjusting or disconnecting.
2. Wear proper hand and eye protection when searching for leaks. Use wood or cardboard instead of hands.
3. Keep all components in good repair.

505-3-0315

12 - PN 50530315

OPERATOR SIGN-OFF RECORD

Safety is a primary concern in the design and manufacture of our products. Unfortunately, our efforts to provide safe equipment can be wiped out by an operator's single careless act.

In addition to the design and configuration of equipment, hazard control and accident prevention are dependent upon the awareness, concern, judgement, and proper training of personnel involved in the operation, transport, maintenance and storage of equipment.

It has been said "The best safety device is an informed, careful operator." We ask you to be that kind of operator.

Agricultural Engineers (ASAE) and the Occupational Safety and Health Administration (OSHA).

Anyone who will be operating and/or maintaining the Center Drive Shredder must read and clearly understand all Safety, Operating, and Service & Maintenance information presented in this manual.

Do not operate or allow anyone else to operate this equipment until this information has been reviewed. Review this information annually, before the season start-up. Make periodic reviews of the Safety and Operation sections a standard practice for those using any of your equipment.

Use the following Operator Sign-off Record to verify that each operator has read and understood the information in this manual and has been instructed in the safe operation of the Shredder.

Alloway Equipment Company follows the general safety standards specified by the American Society of

DATE	OPERATOR'S NAME	OPERATOR'S SIGNATURE

OPERATION

Safety is a primary concern in the design and manufacture of our products. Unfortunately, our efforts to provide safe equipment can be wiped out by an operator's single careless act.

In addition to the design and configuration of equipment, hazard control and accident prevention are dependent upon the awareness, concern, judgment, and proper training of personnel involved in the operation, transport, maintenance and storage of equipment.

It has been said "The best safety device is an informed, careful operator." We ask you to be that kind of operator.

The Alloway Flail Shredder is designed to pick up and shred crop and plant residue left in the field. Rotational power to the flails is provided by the tractor PTO.

Be familiar with the flail shredder before starting.

The owner is responsible for training operators in the safe operation of the flail shredder.

WARNING

- **Safety instructions are important! Read all attachment and power unit manuals; follow all safety rules and safety decal information. (Replacement manuals are available from your Alloway dealer.) Failure to follow instructions or safety rules can result in serious injury or death.**
- **Never allow children or untrained persons to operate equipment.**
- **Make sure shields and guards are properly installed and in good condition. Replace if damaged.**
- **Keep hands, feet, hair, and clothing away from equipment while engine is running. Stay clear of all moving parts.**
- **Before dismounting power unit or performing any service or maintenance, follow these steps: disengage power to equipment, lower the 3-point hitch and all raised components to the ground, operate valve levers to release any hydraulic pressure, set parking brake, stop engine, remove key, and unfasten seat belt.**
- **Never allow riders on power unit or attachment.**
- **Do not allow bystanders in the area when operating, attaching, removing, assembling, or servicing equipment.**
- **Keep hands, feet, hair, and clothing away from equipment while engine is running. Stay clear of all moving parts.**

CAUTION

- **Always sit in power unit seat when operating controls or starting engine. Securely fasten seat belt, place transmission in neutral, engage brake, and ensure all other controls are disengaged before starting power unit engine.**
- **Never allow riders on power unit or attachment.**
- **Keep bystanders away from equipment.**
- **Operate tractor PTO at the RPM speed stated in "Specifications" section.**
- **Always comply with all state and local lighting and marking requirements.**
- **Always wear relatively tight and belted clothing to avoid entanglement in moving parts. Wear sturdy, rough-soled work shoes and protective equipment for eyes, hair, hands, hearing, and head; and respirator or filter mask where appropriate.**

Operation Continued

PRINCIPAL COMPONENTS

The Alloway Flail Shredder consists of a large rotating drum with free-swinging steel flails attached. The flails pick up or strike crop residue or trash and shred it. Rotational power to the drum is provided by the tractor PTO through a gearbox in the center of the machine.

For removing the center strip of crop residue, an optional hydraulically driven blade can be installed under the cover in the center of the machine.

The flail shredder is designed to be used as a pull-type, semi-mounted, or 3-point mounted machine.

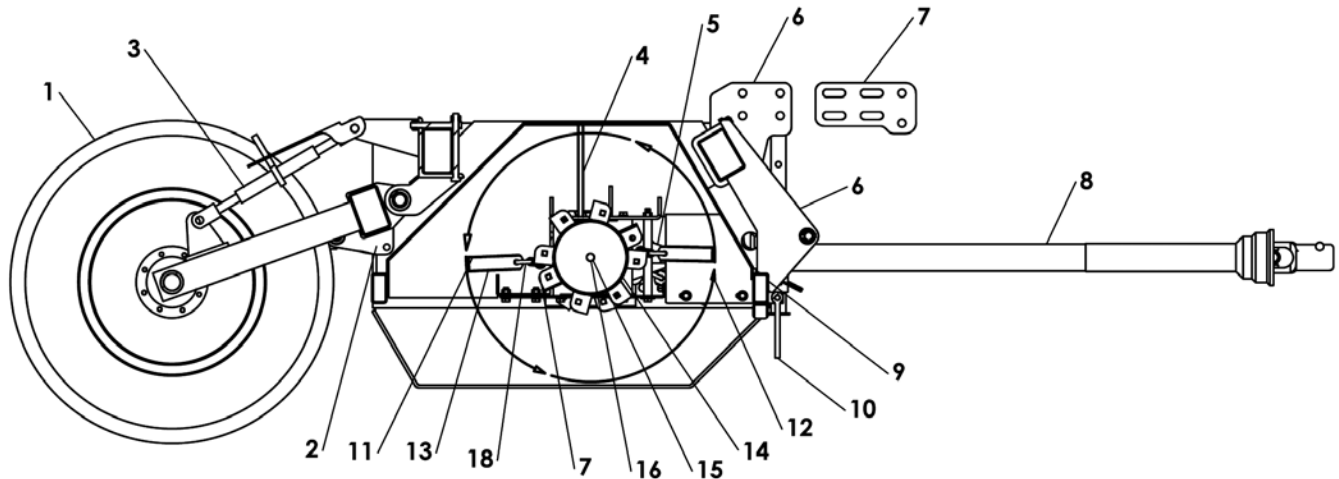

Figure 1a. Flail Shredder with 3-Pt Hitch Principal Components

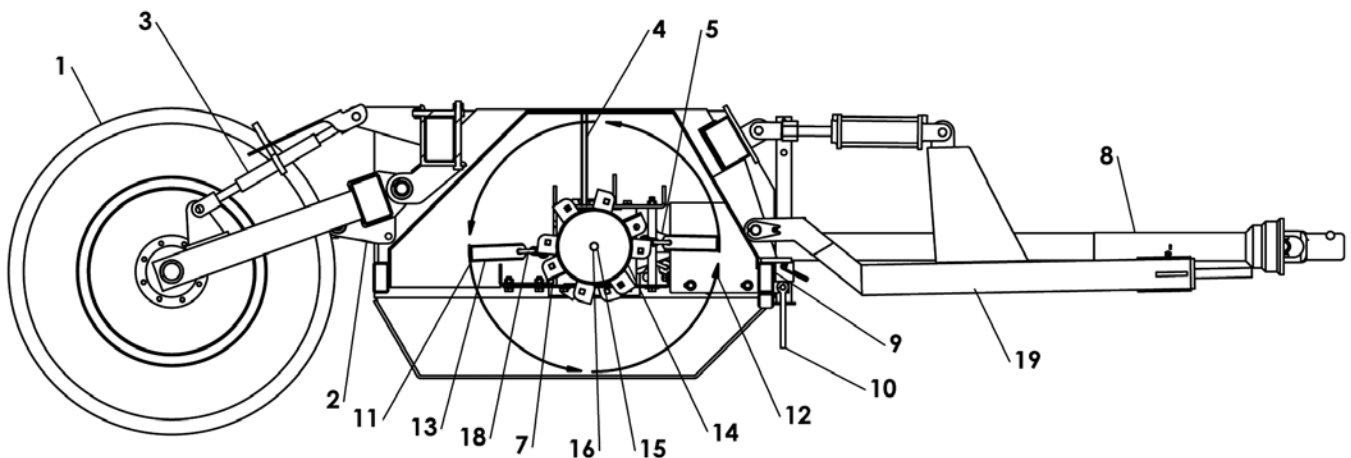

Figure 1b. Pull Type Flail Shredder Principal Components

- | | |
|------------------|-----------------------------|
| 1. Wheels | 10. Rubber shield flaps |
| 2. Rear hitch | 11. Flails |
| 3. Ratchet | 12. Tip speed |
| 4. Dipstick | 13. Cup or "L" Knife flails |
| 5. Gearbox | 14. Rotor (Flail Tube) |
| 6. 3-Point hitch | 15. End bearing |
| 7. Floating mast | 16. Stub shaft |
| 8. Driveline | 17. Flail Tube Clip |
| 9. Frame | 18. D-Ring |
| | 19. Pull Type Hitch |

Operation Continued

PRE-OPERATION CHECK LIST

(OWNER'S RESPONSIBILITY) *Continued*

IMPORTANT

■ This Pre-Operation Check List is provided for the operator. It is important to follow for both personal safety and maintenance of the flail shredder.

- ___ Check all lubrication points and grease as instructed in Lubrication Schedule, page 33.
- ___ Use only a tractor of adequate power and weight to pull the unit.
- ___ Check that the unit is properly attached to the tractor. On pull-type unit, be sure there is a mechanical retainer through the drawbar pin and the safety chain is installed. On 3-point hitch units, be sure retainers are used on the mounting pins.
- ___ Check oil level in gearbox. Add oil as required.
- ___ Check that the PTO driveline turns freely and that the driveline can telescope easily.
- ___ Check tire pressure. Bring to specified level.
- ___ Check flails. Inspect for damage or breakage. Make sure the swing freely on their mount. Repair or replace as required.
- ___ Check condition of cutter blade (if so equipped).
- ___ Inspect all hydraulic lines, hoses, couplers, and fittings. Tighten, repair, or replace any leaking or damaged components.
- ___ Install and secure all guards, doors, and covers.
- ___ Check PTO clutch operation (See Servicing Weasler Modular Friction Clutch, page 44).

Choosing the Correct Equipment

To ensure safe and reliable operation of the flail shredder, use a tractor with the correct specifications. Use the following guidelines to select the correct tractor.

1. Horsepower

Use Table 1 for selecting the tractor horsepower class appropriate for your unit's width.

Increase the horsepower level by 25 percent when operating in hilly, soft, or wet conditions.

2. Tractor Weight

By following recommendations for tractor horsepower, the tractor will have sufficient weight to provide stability for unit during field operation or when transporting.

When using a 3-point mounted shredder, it is recommended that each tractor be equipped with a full complement of suitcase weights on the tractor front (see Figure 2 for example). This will provide the required front weight for turning and extra traction if equipped with front wheel assist.

Width	Minimum Horsepower
12'	60
15'	75
18'	90
20'	100
22'	110
25'	120
27'	140
30'	150

Table 1: Tractor Horsepower vs. Unit Width

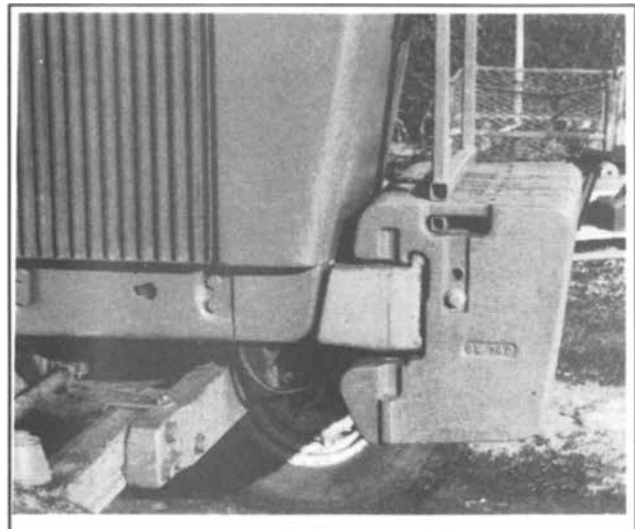

Figure 2. DTractor Front Weights

Operation Continued

Choosing the Correct Equipment (Cont'd)

3. 3-Point Hitch

The 3-point hitch models require the tractor to be equipped with a Category II or Category III 3-point hitch. If the hitch can be converted from one to the other, use a Category III to provide a wider stance and more stability.

Use the upper pin hole for Category III and the lower hole for Category II as shown in Figure 3.

For easier attachment, use a quick hitch. If not using a quick hitch, use optional hitch extension.

4. Load Sensing Hydraulics (3-Point models only)

Many newer tractors are equipped with "load sensing" hydraulics. The operator is responsible for setting the tractor hydraulic

system to provide "float" on the 3-point hitch. Refer to the tractor manual for specific instructions.

The "float" feature will allow the unit to follow the ground contours during operation. This applies to 3-point mounted machines only.



Figure 3. 3-Point Hitch Attachment

5. Drawbar (Pull-type models only)

The tractor drawbar must be set to provide 16" - 20" (406 mm - 508 mm) between the end of the PTO shaft and the center of the drawbar pin for all and 1000 rpm PTO. See Figure 4. This dimension will provide the required clearance for the CV (Constant Velocity) joint on the front of the driveline.

IMPORTANT

- Do not use PTO shaft adapters. They will change the drawbar dimension and can cause driveline failures.

NOTE: On pull-type models, do not cut driveline.

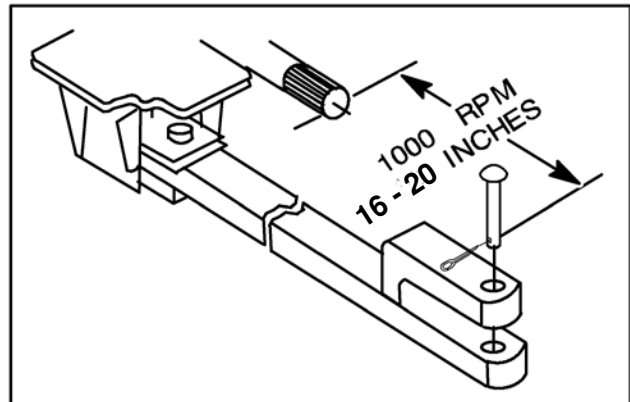

Figure 4. Drawbar Dimensions

Break-in of the Flail Shredder

The following should be observed when operating the unit for the first time:

IMPORTANT

- Before operating the unit in the field, run the PTO clutch. See Servicing Weasler Modular Friction Clutch, page 44.

After operating for 1/2 hour

1. Check all nuts, bolts, and other fasteners. Tighten to specifications given in the Bolt Torque Chart, page 72.
2. Tighten wheel bolts to specifications given in the

Bolt Torque Chart, page 72.

3. Check that the flails are in good condition and swing freely.
4. Check oil level in the gearbox. Add oil if needed.
5. Check that the PTO driveline shield turns freely.
6. Lubricate all grease points.

After operating for 5 to 10 hours

1. Repeat Steps 1 to 5 above.
2. Follow regular service schedule as outlined in Service & Maintenance.

Operation Continued

PTO Driveline Length (3-Point & 2-Point models only)

The unit is equipped with a PTO driveline long enough to fit any tractor and 3-point linkage system.

The operator is responsible for measuring the dimensions of the driveline through its working range. These dimensions will indicate if the driveline requires shortening to operate on the particular tractor/unit attachment system. The operator must check dimensions before using the unit for the first time and each time a different tractor is used with the unit

Use the following procedure when determining driveline dimension:

1. Clear the area of bystanders, especially children.

WARNING

- **Keep bystanders away from equipment.**
2. Attach the 3-point hitch to the unit but not the PTO driveline.
 3. Raise the unit until the tractor PTO and gearbox shafts are the same height.
 4. Measure the dimension between the shaft grooves on the tractor and implement ends. If this dimension is less than 34.81 inches, the shaft will require shortening.

5. Move the unit to its highest and lowest working position and measure this dimension again. The unit's shaft can telescope (see Figure 6) before it has been shortened.

6. If required, shorten the shaft to prevent bottoming out during use. NOTE: An extra inch of compression space in the shaft can eliminate bottoming out during use. Measure to make sure.

7. Use an abrasive wheel power saw to cut the male end of the shaft. Cut the same amount from both the splined shaft and the safety shield. See Figure 5. Use a file to remove any burrs from the cut end.

IMPORTANT

- **Cut only the male end. Never cut the female end.**

8. Never cut more than 9 inches from the male end. Cutting 1 inch from the male end shortens both the minimum and maximum lengths by 1 inch.

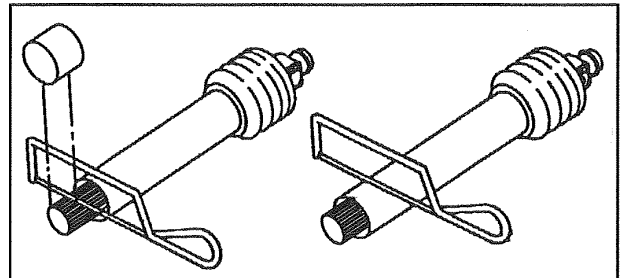

Figure 5. Cutting the Driveline Shaft

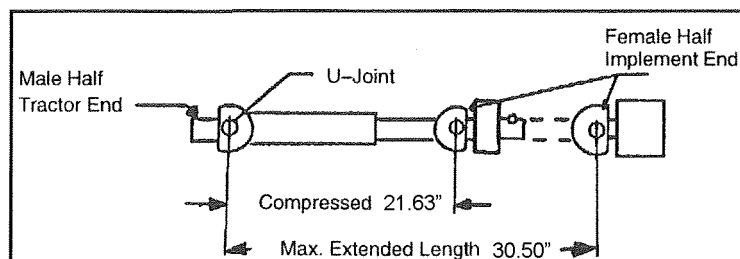

Figure 6. Driveline Dimension - 3-Pt Hitch

Operation Continued

Attaching the Shredder to the Tractor

1. Place unit on a level, dry area free of debris and other foreign object.

⚠ WARNING

- Keep bystanders away from equipment.

2. Clear the area of bystanders, especially children.

3. Provide enough clearance to back the tractor safely into the unit.

⚠ CAUTION

- Do not allow anyone to stand between tractor and unit when backing up to the unit.

3-point and 2-point models:

4. Set the height of the 3-point hitch so that quick hitch claws are lower than the mounting pins.
5. Make sure 3-point hitch is set in the non-sway position. See tractor manual for details.
6. Align the claws under the mounting pins (see Figure 7) while backing up.

NOTE: For a Category II hitch, use the bottom hole for the center pin. For a Category III hitch, use the top hole for the center pin.

7. When the claws are under the pins, slowly raise the 3-point hitch. Make sure each mounting pin seats in its respective claw.
8. Release the claw retainer locks to secure the mounting pins in the claws.
9. Check the top link frame. It should be free to slide

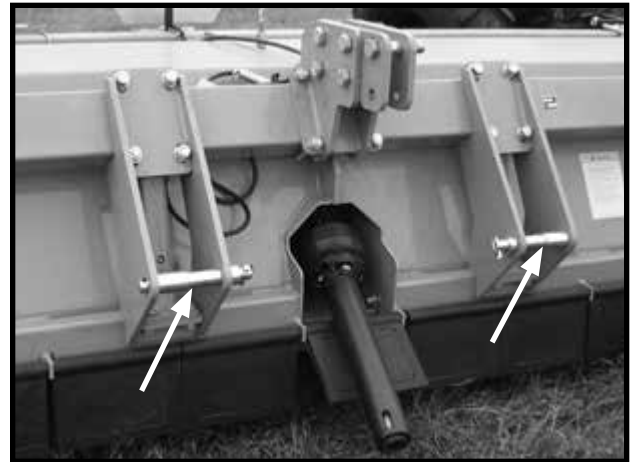

Figure 7. Attaching to 3-point model

in its mounting slots. This movement allows the unit to follow the ground contour when cresting a hill or going through a depression.

Pull-type model:

4. Use the ratchet (see Figure 8) on top of the hitch to set the hitch height.
5. Check and set the drawbar dimension.
6. Back the tractor up to the hitch.
7. Use a hardened drawbar pin that provides for a mechanical retainer, such as a Klik pin.
8. Attach a safety chain around the drawbar or cage to prevent unexpected separation. Provide sufficient slack for turning.
9. Use the ratchet to transfer the unit's weight to the drawbar.
10. Make sure the drawbar is pinned in its center position.

Attach PTO Driveline

11. Make sure the driveline telescopes easily and shields rotate freely.

IMPORTANT

- The drawbar may need repositioning to provide clearance for the driveline.



Figure 8. Attaching to Pull-type model

12. Attach the driveline to the tractor by retracting the locking collar. Slide the yoke over the shaft and push on the yoke until the lock collar clicks into position. Make sure the yoke is locked into position. See Figure 9.

Attach Hydraulics

13. Use a clean cloth to clean hose ends and area around the couplers on the tractor.

Operation Continued

Attaching the Shredder to the Tractor

(Cont'd)

14. Insert the hose male ends into the tractor couplers. Make sure hoses lock in place.

15. Route hoses along or over the hitch and secure in position with clips, tape, or plastic ties. Provide enough slack for turning and lifting.

Raise Stands

16. Use hitch ratchets or 3-point hitch to raise the front of the machine.

17. Unpin front frame stands. Raise and pin in their upper position. See Figure 10.

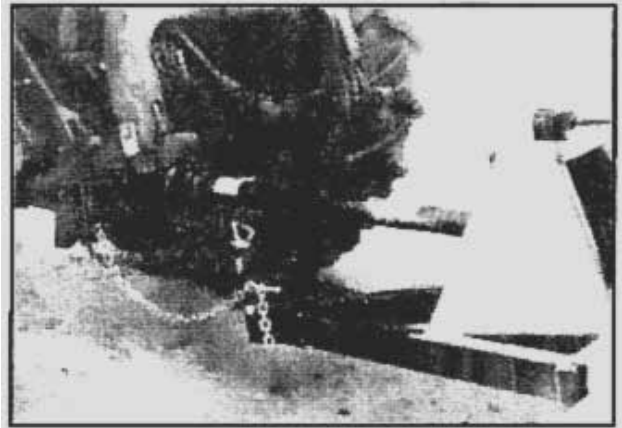

Figure 9. Belt Drive

Removing the Shredder from the Tractor

1. Reverse the above procedure (Steps 1-17) when removing unit from the tractor.



Figure 10. Parking Stand

Field Operation

The Alloway Flail Shredder is designed with the flexibility to operate well in almost any kind of crop and terrain conditions. However, the operator is responsible for being familiar with all operating and safety procedures and following them.

Each operator should review this Field Operation

section at the start of the season and as often as required to be familiar with the unit.

Operators should also review the PRE-OPERATION CHECK LIST, Attaching the Shredder to the Tractor, and Transporting the Unit.

WARNING

- Safety instructions are important! Read all attachment and power unit manuals; follow all safety rules and safety decal information. (Replacement manuals are available from your Alloway dealer.) Failure to follow instructions or safety rules can result in serious injury or death.
- Never allow children or untrained persons to operate equipment.

- Make sure shields and guards are properly installed and in good condition. Replace if damaged.
- Keep hands, feet, hair, and clothing away from equipment while engine is running. Stay clear of all moving parts.
- Before dismounting power unit or performing any service or maintenance, follow these steps: disengage power to equipment, lower the 3-point hitch and all raised components to the ground, operate valve levers to release any hydraulic pressure, set parking brake,

Field Operation *Continued*

WARNING

stop engine, remove key, and unfasten seat belt.

- Never allow riders on power unit or attachment.
- Do not allow bystanders in the area when operating, attaching, removing, assembling, or servicing equipment.
- Inspect and clear area of stones, branches, or other hard objects that might be thrown, causing injury or damage.
- Operators must be instructed in and be capable of the safe operation of the equipment, its attachments, and all controls. Do not allow anyone to operate this equipment without proper instructions.

CAUTION

- Always sit in power unit seat when operating controls or starting engine. Securely fasten seat belt, place transmission in neutral, engage brake, and ensure all other controls are disengaged before starting power unit engine.
- Keep bystanders away from equipment.
- Operate tractor PTO at the RPM speed stated in “Specifications” section.
- Always comply with all state and local lighting and marking requirements.
- Always wear relatively tight and belted clothing to avoid entanglement in moving parts. Wear sturdy, rough-soled work shoes and protective equipment for eyes, hair, hands, hearing, and head; and respirator or filter mask where appropriate.

Transporting the Unit

WARNING

- Never allow riders on power unit or attachment.

CAUTION

- Always comply with all state and local lighting and marking requirements.

1. Be sure all bystanders are clear of the unit.
2. Be sure center cutter is disengaged and has stopped turning (if so equipped).
3. Be sure the unit is securely attached to the tractor and all retainer pins are installed.
4. Be sure safety chain is installed on pull-type model.
5. Raise the machine.
6. Clean the SMV emblem, lights, and reflectors and be sure they are working.

Road Speed	Fully equipped or loaded implement(s) weight relative to towing machine weight
Up to 32 km/h (20 mph)	1 to 1 or less
Up to 16 km/h (10 mph)	2 to 1 or less
Do not tow	more than 2 to 1

Table 2: Speed vs. Weight Ratio

7. Be sure you are in compliance with all applicable lighting and marking regulations when transporting. Check with your local authorities.
8. Never transport the unit faster than 20 mph (32 kmph). The ratio of the tractor weight to the shredder weight plays an important role in defining acceptable travel speed. Table 2 summarizes the recommended travel speed-to-weight ratio.

Field Operation *Continued*

Preparing for Operation

1. Pull into the field and position the unit in a level area.
2. Lower into operating position.
3. 3-Point hitch models: Set the 3-point so the quick hitch is vertical and the floating upper mast is forward.

Flail Height

4. Set the unit to give a flail height of **at least 2-1/2 to 6 inches (75 to 150 mm)** above the ground. This will minimize the amount of stones and dirt picked up by the flails under all operating conditions.

NOTE: To avoid unnecessary wear on knives and related parts, never set the unit lower than the recommended setting.

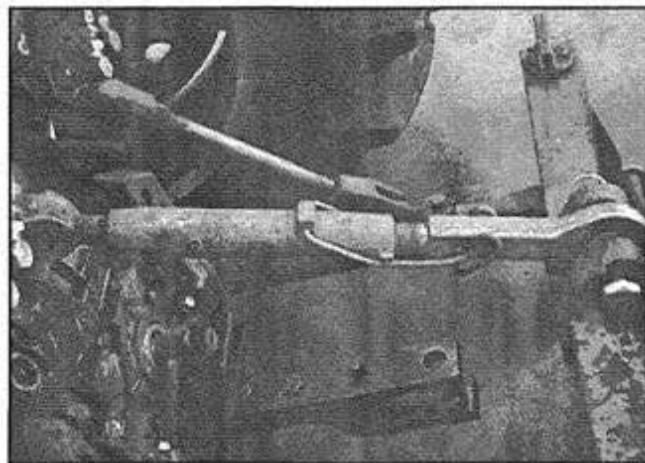

Figure 15. Flail Height

Set Operating Height

3-Point hitch models

Use the ratchet on the cylinder stops on the rear struts and on third link of 3-point to set the unit height.



Figure 16. 3-Point Hitch Models

Pull-type models

Use the cylinders on the hitch and rear struts to set the unit height.



Figure 17. Pull-type Models

Operation *Continued*

3-Point & 2-Point Hitch Models

1. Set lower 3-point arms in the free-float position.
2. Set the hitch in the non-swing position.
3. Set the hydraulic system to allow the 3-point to float. Refer to tractor manual for instructions.
4. **3-Point models only:** Be sure the floating mast is free to slide in its mounting frame to allow the machine to follow ground contours. Refer to Figure 18.

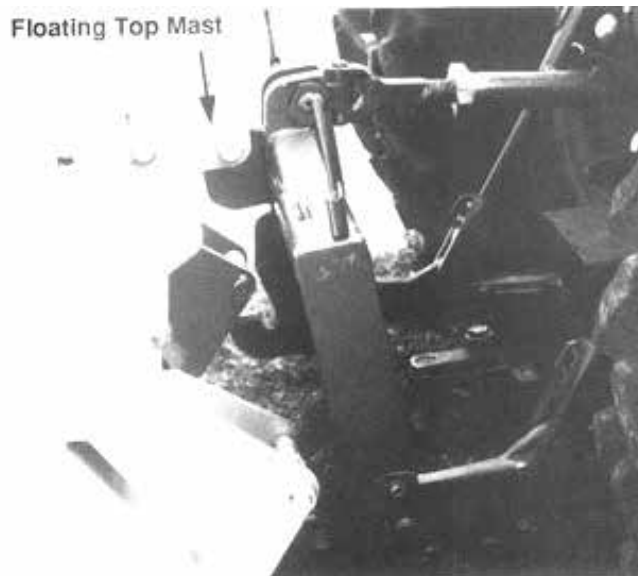

Figure 18. Free-float position

Field Operation *Continued*

Flail Types

The shredder is factory equipped with “L” or cup type flails. The two types are interchangeable.

“L” Flails, “L” Flails w/ D-Ring

“L” flails (Figure 20) work best when trash or crop residue is standing.

Cup Flails

Cup flails (Figure 21) can pick up material from the ground and work best in matted trash conditions.

The standard cup flail is 11 inches (279 mm) long and is used for most applications. Optional 7 and 9 inch (177 and 228 mm) flails are available to match the tip position to ground contour.

Attach optional cup flails as follows (see Figure 19):

1. Leave standard flails located between the rows.
2. Remove others and install shorter flails to follow ground contour. Be sure to mount the same size flails on opposite sides of the tube. Measure the row spacing and flail position carefully to minimize ground contact.

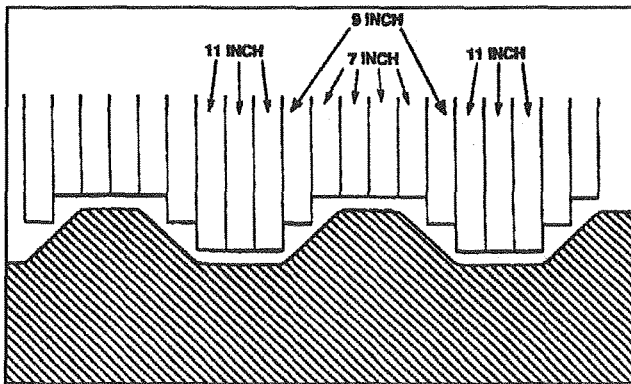

Figure 19. Optional Flail Contour

Setting Flail Height

1. Be sure wheels are set to follow in the center of furrow row. **Set flails 3 to 6 inches (75 to 150 mm) above the ground.**
2. Align the unit with the working area on or between rows on flat farming.



Figure 20. “L” Flails

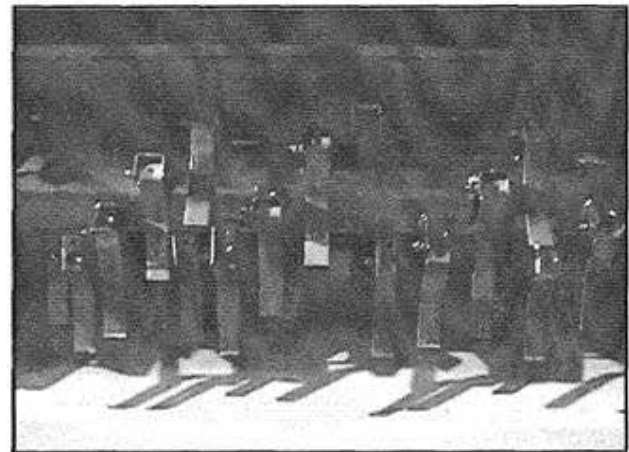

Figure 21. Cup Flails

3. **3-Point models:** Set the 3-point hitch so the wheels carry only a small portion of the unit's weight and act more as stabilizing wheels. See tractor manual for setting hitch.

Field Operation *Continued*

Setting Outer Trailing Wheels

Normally, wheels are set to track in the row centers, between the raised seed beds. Tire position will determine flail height, but depth of furrow is also a factor in setting flail height. In some conditions the furrow between the seed beds is deeper on the ends, where irrigation waters enter the field. As furrows change depth, flail height will change.

To compensate for the depth change, move the trailing wheels against the side of the outer seed bed (see Figure 22). The wheels will then tend to climb up the side of the seed bed and prevent the flails from hitting the top of the bed.

Set the flail height after the wheels have been moved against the seed bed.

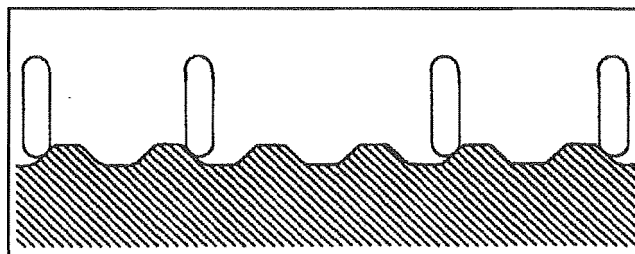

Figure 22. Wheel Position

Adjust wheel position by moving spindle to different hole location in spindle holder tube.

Starting the Tractor

1. Run tractor engine at low idle.
2. Slowly engage PTO control to start the shredder.
3. Slowly bring tractor engine to rated PTO speed. Never exceed rated speed.

Stopping the Tractor

WARNING

■ **Before dismantling power unit or performing any service or maintenance, follow these steps: disengage power to equipment, lower the 3-point hitch and all raised components to the ground, operate valve levers to release any hydraulic pressure, set parking brake, stop engine, remove key, and unfasten seat belt.**

1. Slowly decrease engine speed to low idle.
2. Slowly disengage PTO clutch. The overrunning clutch will allow the shredder to freewheel down,
3. Restart the unit only after the drums quit turning. The PTO will not need to be disengaged to lift the unit on the ends or while turning.

Field Operation *Continued*

Hazard Area

WARNING

- **Make certain all movement of equipment components has stopped before approaching for service.**

Stay away from front, side, and rear of unit while it is running. Flails can pick up stones, sticks, wire, and other debris and throw it out with enough force to severely injure bystanders.

Keep out of shaded area shown in Figure 24.

Shut down unit and wait for moving parts to stop before approaching.

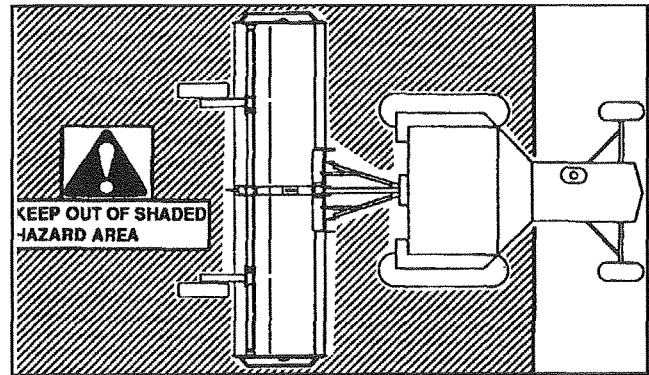

Figure 24. Hazard Area

Ground Speed

Travel speed can vary between 3 and 8 mph (5 and 13 kmph) depending on the bulk of residue and terrain conditions. The operator is responsible for noting the condition of the work, setting the speed to obtain a quality shredding job, and maintaining control of the unit.

Speed may be increased if shredding quality is good.

Decrease speed if trash is left standing or if some is not picked up.

Turning

3-Point mounted units:

Always raise the unit slightly to lift rear wheels off the ground before turning. This will eliminate side loads on the wheel assembly, unless unit is equipped with castor wheels.

Pull-type units:

The front universal is equipped with a CV (Constant Velocity) joint to allow for turning. Although the CV joint allows for sharper turns than a regular drive-line, it does have some limitations. Refer to Figure 25.

CV joint angle should not exceed 80 degrees in either operating or standstill condition of the drive-line. Larger angles will damage the joint.

The angle should never exceed 35 degrees when the driveline is under full load.

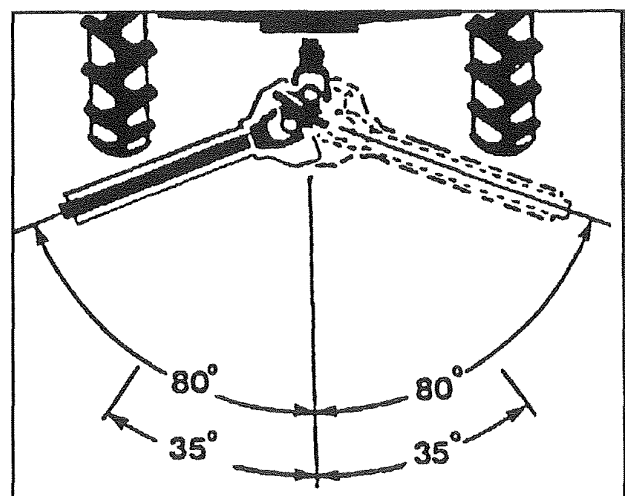

Figure 25. CV Joint Angles

IMPORTANT

- **Disengage PTO when making sharp turns.**

Additional Equipment

Center Divider (Optional)

An optional center divider (Figure 27) can be mounted under the gearbox for pushing trash to the flails.



Figure 27. Optional Center Divider

Front Shield Flap

All units are equipped front shield flaps (Figure 28) along the front of the frame. The shield flaps stop or deflect any trash, stones, or other debris picked up by the flails.

Be sure the shield flaps are in good condition for operation. Replace if damaged, torn, or missing.



Figure 28. Front Shield Flap

End Guards & Skids

All units are equipped with end guard skids (Figure 29) to prevent flying debris or flail-to-ground contact.

 **WARNING**

- Replace damaged or missing skids immediately.



Figure 29. Skids

STORAGE

WARNING

- **Block equipment securely for storage.**
- **Keep children and bystanders away from storage area.**

At the end of the season, the shredder should be thoroughly inspected and prepared for storage. Repair or replace any worn or damaged components to prevent unnecessary down time at the beginning of the next season.

To ensure a long, trouble-free life, prepare the unit for storage by carrying out the following procedure:

1. Clear the area of bystanders, especially children.
2. Thoroughly wash the unit, using a pressure washer to remove all dirt, mud, debris, and residue.
3. Inspect the flails and rotors for damage or entangled material. Remove entangled material. Repair or replace damaged parts.
4. Inspect all hydraulic hoses, lines, couplers, and fittings. Tighten all loose fittings. Replace any hose that is cut, nicked, abraded, or separating from the crimped end of a fitting.
5. Change gearbox oil.
6. Lubricate all grease fittings. Make sure all grease cavities have been filled with grease to remove any water residue from pressure washing.
7. Touch up all paint nicks and scratches to prevent rust.
8. Move to storage area. Select a dry area free of debris. Store in an area away from human activity.
9. Unhook from tractor (see Removing the Shredder from the Tractor, page 18).
10. Place safety stands or large blocks under the frame to take the load off the tires.
NOTE: Do not deflate tires.
11. If the unit cannot be placed indoors, cover with a waterproof tarpaulin and tie securely. Store away from human activity.
12. Do not allow children to play on or around the stored unit.

SERVICE & MAINTENANCE

WARNING

■ Before dismounting power unit or performing any service or maintenance, follow these steps: disengage power to equipment, lower the 3-point hitch and all raised components to the ground, operate valve levers to release any hydraulic pressure, set parking brake, stop engine, remove key, and unfasten seat belt.

■ Before working underneath, read manual instructions, securely block up, and check stability. Secure blocking prevents equipment from dropping due to hydraulic leak down, hydraulic system failure, or mechanical component failure.

■ Keep all persons away from operator control area while performing adjustments, service, or maintenance.

■ Make sure shields and guards are properly installed and in good condition. Replace if damaged.

■ Do not handle blades with bare hands. Careless or improper handling may result in serious injury.

CAUTION

■ Always wear relatively tight and belted clothing to avoid entanglement in moving parts. Wear sturdy, rough-soled work shoes and protective equipment for eyes, hair, hands, hearing, and head; and respirator or filter mask where appropriate.

■ Make certain all movement of equipment components has stopped before approaching for service.

Lubricants

1. Grease

Use an SAE multi-purpose high temperature grease with extreme pressure (EP) performance. An SAE multi-purpose lithium-based grease is also acceptable.

2. Gearbox Oil

Use an SAE 85W90 gear oil for all operating conditions. Capacity: 2-1/2 U.S. quarts (2.13 liters)

3. Storing Lubricants

Your unit can operate at top efficiency only if clean lubricants are used. Use clean containers to handle all lubricants. Store them in an area protected from dust, moisture, and other contaminants.

Greasing

NOTE: Use the Lubrication Service Record, page 36 to keep a record of all scheduled maintenance.

1. Use a hand-held grease gun for all greasing.
2. Wipe grease fitting with a clean cloth before greasing to avoid injecting dirt and grit.
3. Replace and repair broken fittings immediately.
4. If fittings will not take grease, remove and clean thoroughly. Also clean lubricant passageway. Replace fitting if necessary.

Service & Maintenance *Continued*

Lubrication Schedule

NOTE: Recommendations are based on normal operating conditions. Severe or unusual conditions may require more frequent lubrication or oil changes. Refer to Figure 30.

Daily or every 8 hours of operation

PTO Driveline Lubricate daily or every 8 hours of operation (every 4 hours if U-joints run at angles). See Figure 29 for lubrication points.

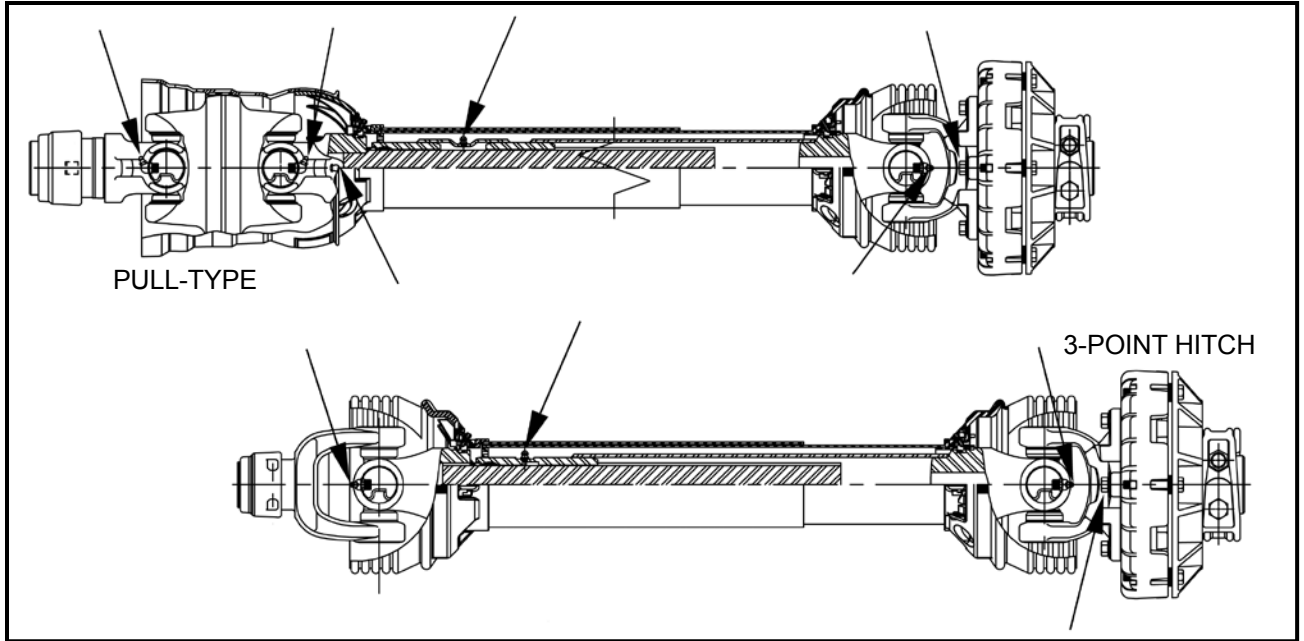

Figure 29. PTO Driveline Lubrication Points

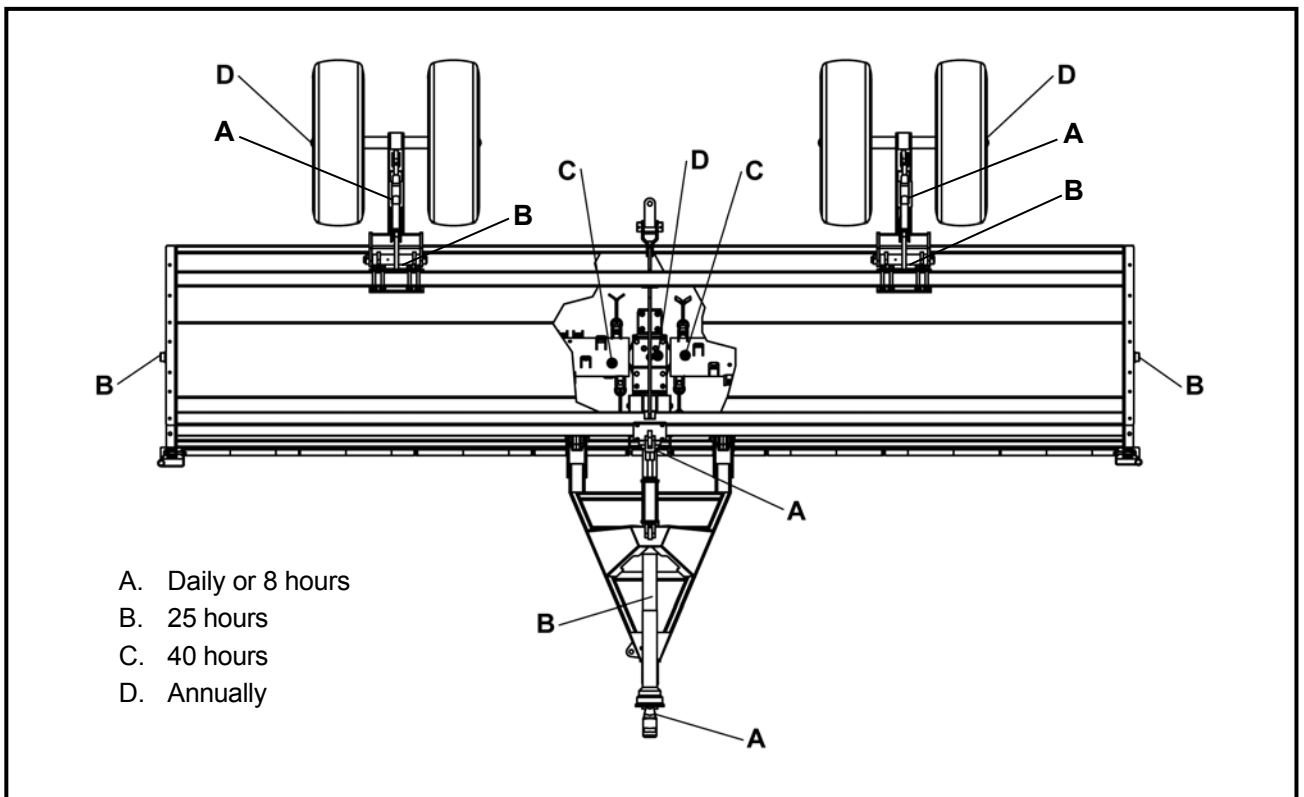

Figure 30. Lubrication Points

Service & Maintenance *Continued*

Lubrication Schedule *(Cont'd)*

Daily or every 8 hours of operation

1. Check gearbox daily or every 8 hours of operation. See Figure 31 for gearbox oil fill location

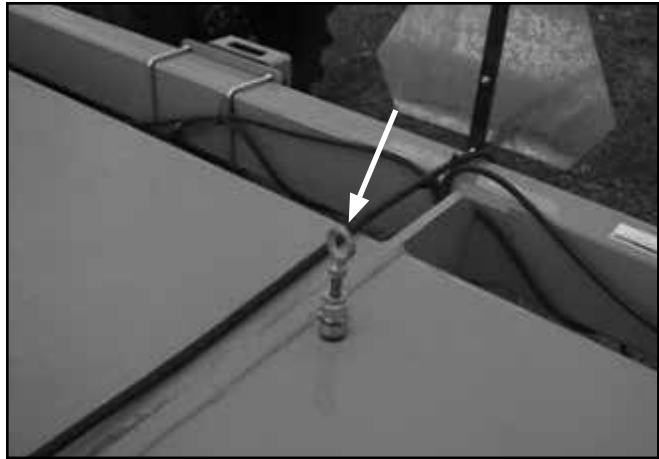

Figure 31. Gearbox Oil Fill Location

Every 25 hours of operation

1. Lubricate PTO driveline telescoping section (1 location, Position B, Figure 30).
2. Lubricate rotor end bearings. See Figure 32.



Figure 32. Rotor End Bearing Lubrication Point

3. Lubricate wheel strut pivots (3 to 5 locations). See Figure 33.



Figure 33. Wheel Strut Pivot Bearing Lubrication Points

Service & Maintenance *Continued*

Lubrication Schedule *(Cont'd)*

Every 40 hours of operation

1. Lubricate rotor drive hubs next to the couplers on underside of unit (2 locations). See Figure 34.
2. Grease the drive hubs with 10 to 20 shots. You may use extra grease only on drive hubs.

Annually

1. Change gearbox oil. Refill with SAE 85W90 gear oil. See Figure 34.

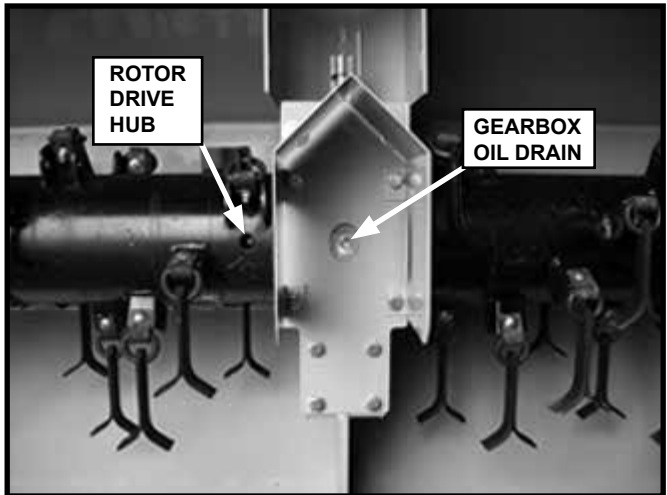

Figure 34. Rotor Drive Hub Lubrication Points & Gearbox Oil Drain Location

2. Repack wheel bearings. See Figure 35.



Figure 35. Wheel Bearings

3. Lubricate ratchets as necessary (2 locations each ratchet). See Figure 36.

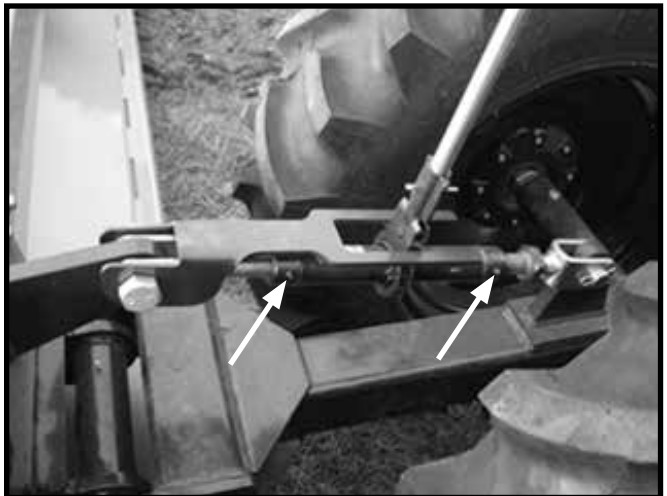

Figure 36. Ratchet Lubrication Points

Service & Maintenance *Continued*

Lubrication Service Record

✓ CHECK

C CHANGE

NOTE: See page 33 through page 35 for details.
Copy this page to continue service record.

L LUBRICATE

R REPACK

HOURS OF SERVICE																			
SERVICED BY																			
10 Hours or daily																			
L PTO Driveline (8)																			
L PTO Driveline telescope section																			
L U-Joint(1)																			
L Overrunning clutch (1)																			
✓ Gearbox oil level																			
25 Hours																			
L Rotor end bearings																			
L Wheel mounting tube bearings																			
40 Hours																			
L Rotor inner bearings (2)																			
Annually																			
C Gearbox oil																			
R Wheel bearings																			

Service & Maintenance *Continued*

Acceptable Oil Leakage from Gearbox

Not all gearbox oil leakage or seepage is serious.

IMPORTANT

■ Gearbox oil seepage is acceptable if

1. Oil covers less than a 3-inch diameter area around the shaft seal area (see Figure 37).
2. Oil covers 4 inches around the vent or drain plugs (see Figure 37).

if oil covers an area larger than that described in 1 & 2, do the following:

- a. Check gearbox oil level. If it is low, fill to proper level.
- b. Clean oily area of gearbox. Use a degreaser to remove all oil.
- c. Closely monitor gearbox for 10 hours of operation. Check oil level often.
- d. If after 10 hours of operation oil covers less than area described in 1 & 2 above, leakage is acceptable.

NOTE: Warranty only covers oil leakage that is in excess of above limits.

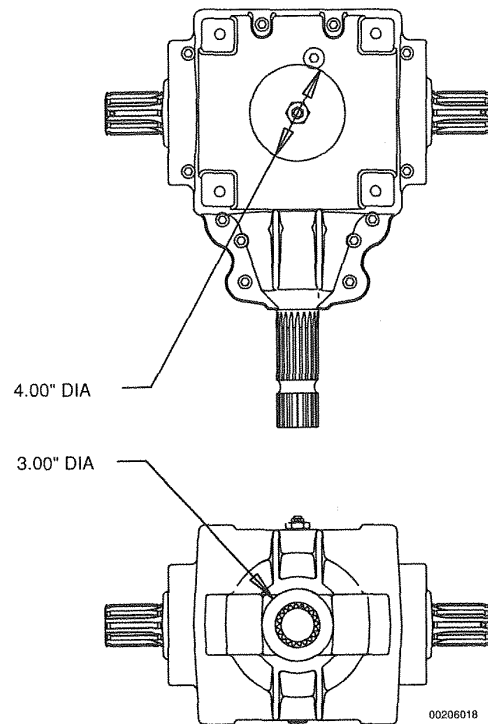

Figure 37. Acceptable Oil Leakage

Changing Gearbox Oil

Although gearbox oil never wears out, dust, dirt, and moisture can enter through the breather during operation. These contaminants must be removed once a year to ensure a long life for working components. In very dusty or dirty conditions, change the oil twice a year.

1. Clear area of bystanders, especially children.
2. Shut off tractor, place all controls in neutral, set parking brake, remove key, and wait for all moving parts to stop.
3. Raise the unit to provide access to underside. Place safety stands or large blocks under frame.
4. Disconnect PTO driveline and hydraulic lines.
5. Place a pan under drain plug. Remove drain plug and dip stick plug (see Figure 38).
6. Allow gearbox to drain for 10 minutes.

NOTE: To remove the most contaminants, drain oil when gearbox is hot.

7. Re-install and tighten drain plug.
8. Dispose of used oil in an approved container.
9. Add SAE 85W90 gear oil through the dip stick cover. Use the dip stick to check the oil level (Figure 39) and add oil accordingly.
10. Re-install and tighten fill plug.
11. Reconnect PTO driveline and hydraulic lines.
12. Remove blocks or safety stands.



Figure 38. Drain Plug (underside of unit)



Figure 39. Dipstick Location

Service & Maintenance *Continued*

Setting Ratchets

Mechanical ratchets provide height setting for the unit. To set ratchets, follow this procedure:

1. Clear the area of bystanders, especially children.
2. Turn the turnbuckle to achieve the desired ratchet length (see Figure 39).
3. Repeat Step 2 with other ratchets.

Wheel Spacing

The rear wheels can be adjusted for alignment with crop rows.

1. Clear the area of bystanders, especially children.
2. Shut off tractor, place all controls in neutral, set parking brake, remove key, and wait for all moving parts to stop.
3. Use a jack with sufficient capacity to lift the frame.
4. To determine wheel spacing, measure from the center line of the unit. Mark positions on the frame.
5. Lift frame until wheels have cleared the ground.
6. Place safety stands or large blocks under the frame.
7. Loosen mounting bolts on one wheel assembly.
8. Slide assembly along the frame tube to new position (see Figure 40).
9. Tighten mounting bolts to specified torque level.
10. Remove safety stands or blocks.
11. Lower and remove jack.
12. Repeat with other wheel assembly.



Figure 40. Positioning Wheel Assembly

Replacing Flails “L” Knife w/ D-Ring

WARNING

- **Do not handle blades with bare hands. Careless or improper handling may result in serious injury.**

The flails swing on D rings, which are sandwiched between clips and mounted to the flail tube with bolts. Regularly inspect the flails for wear or damage. To replace worn or damaged flails, follow this procedure:

1. Clear the area of bystanders, especially children.
2. Shut off tractor, place all controls in neutral, set parking brake, remove key, and wait for all moving parts to stop.
3. Disconnect driveline and hydraulic lines from the tractor.
4. Place safety stands or large blocks under the frame.
5. Loosen and remove the mounting bolt on the worn flail and its opposite on the other side of the rotor. Discard worn flails and their mounting hardware.
6. Replace with new flails and and mounting hardware (see Figure 41).

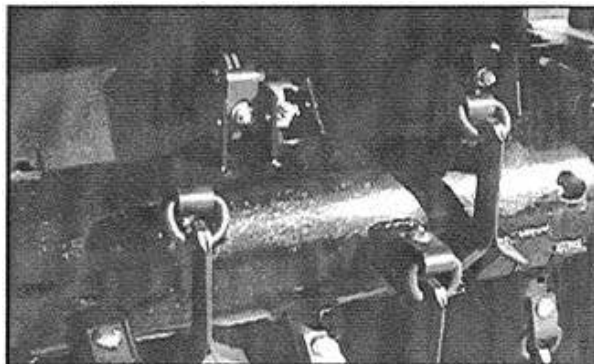

Figure 41. Flail Replacement

IMPORTANT

- **To maintain rotor balance, always replace opposite pairs of flails and mounting hardware.**

7. Tighten flail mounting bolt to its specified torque.
8. Replace additional worn flails following Step 5 and Step 6.
9. Remove safety stands or blocks from under frame.
10. Lower unit and remove jack.
11. Attach driveline and hydraulic line to tractor.

Replacing Rubber Shield Flaps

Rubber shield flaps on the front of the unit deflect or prevent stones or debris from being ejected when operating unit. Replace if damaged or missing to provide a safe work environment. To replace, follow this procedure:

1. Clear the area of bystanders, especially children.
2. Lower the unit to the ground, place all controls in neutral, shut off engine, set park brake, remove key, and wait for all moving parts to stop before dismounting.

NOTE: For 3-point hitch units, unhook to gain access to center flaps.

3. Remove the cotter pin from the end of the flap rod and pull rod until the flap comes off.
4. Install new shield flap.
5. Push rod through flaps and re-install cotter pin.



Figure 42. Front Rubber Shield Flaps

NOTE: Use only genuine Alloway parts when replacing flaps.

Servicing Rotors

The shredder rotors are dynamically balanced from the factory and should be maintained to keep them in balance and to prevent excessive wear on drive components.

IMPORTANT

■ Any vibration caused by missing knives or worn drive components can cause excessive damage to the shredder. Vibration is also transmitted through the PTO shaft to the tractor and will damage tractor

When servicing rotors, follow this procedure:

1. Clear the area of bystanders, especially children.
2. Shut off tractor, place all controls in neutral, set park brake, remove key, and wait for all moving parts to stop.
3. Disconnect unit from the tractor.
4. Remove the PTO driveline from the unit.
5. Remove wheel arms.
6. Use a hoist, crane, or a frame of sufficient capacity to raise the front of the unit and allow back of unit to rest on a solid surface.

CAUTION

■ Use a suitable lifting device of sufficient capacity. Use adequate personnel to handle heavy components.

7. Leave lifting device attached while working on rotors to prevent tipping.
8. Remove knives. Wear heavy canvas or leather gloves to protect your hands.

Removing components:

1. With unit raised (Step 6), support each end of rotor with crane or hoist.
2. Remove bearing locking collar (see Figure 44).
3. Remove 8 bolts holding bearing plate to body assembly.
4. Slide rotor out to disengage from the center drive hub.
5. Check drive hubs for wear and replace if necessary. If O-ring grease seal is cut or worn, replace it.
6. Remove gearbox if damaged.

Replacing components:

Place new stud bolts into gearbox, using Loctite® No. 271 or equivalent.

7. Remount gearbox.
8. Insert outer shaft through end plate hole.
9. Install drive hub to gearbox output shaft. Thoroughly clean both halves of the drive couplers and apply new grease to all gear teeth.

NOTE: When replacing flail tube, you will have to remove the grease zerk to allow air to purge from the coupler assembly. Then replace grease fitting and follow lubrication schedule.

10. Install bearing plate bolts and tighten to specified torque.

IMPORTANT

■ To keep drive hub bolts from loosening, use Loctite No. 271 or equivalent and special Hi-Collar lock washers.

11. Re-install locking collar and tighten in the direction of rotation (see Figure 44).

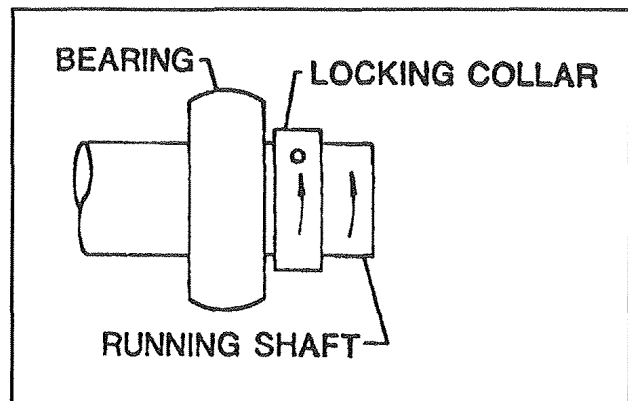

Figure 44. Locking Collar



Figure 45. Rotor Direction of Rotation

a. Loctite is a registered trademark of the Loctite Corporation.

Service & Maintenance *Continued*

Replacing Stub Shaft

1. Remove rotor (see Servicing Rotors, page 41).
2. Remove three 1/2 x 2-1/2 hex bolts in taper lock hub and re-install bolts in three threaded holes (see Figure 46).
3. Tighten bolts evenly to release taper lock hub from stub shaft. **NOTE:** You may have to give a sharp blow directly to each bolt head to help the hub disengage.
4. Unscrew stub shaft from the rotor tube.
5. Install new stub shaft, reversing Steps 1-3.

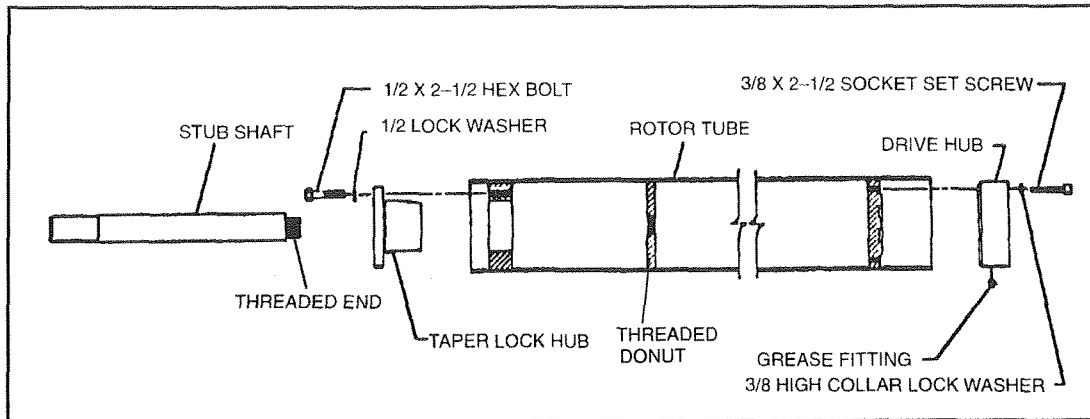

Figure 46. Stub Shaft Assembly

Servicing Weasler Modular Friction Clutch

Tools Required

- 3/4" Socket wrench
- 8" Minimum C-clamps (2)
- 1/4" Hex Allen wrench
- Regular screwdriver or punch
- Duct tape or locking pliers with 3" throat minimum
- Hammer
- 1/2" sq. to 1"sq. barx 9"
- Scale or Vernier

Breaking in the Clutch (Run In)

NOTE: All new clutches must be broken in (Run in) and any clutch that has not been used for approximately 60 days.

1. Shut off tractor and disengage PTO.
2. Disconnect driveline from the tractor PTO shaft.
3. Loosen the bolts on the outside diameter of the clutch until all bolts are just loose, then tighten all bolts 1/2 turn.
4. Attach the shredder to the tractor and the drive-line to the tractor PTO. Stand clear of the unit.
5. Start tractor. Engage PTO clutch and run for a few seconds or until clutch visibly smokes.
6. Disengage PTO. Shut off tractor. Disconnect driveline from the tractor.
7. Tighten all bolts on the outside diameter of the clutch until the compression plate is tight against the housing.
8. Grease the fitting on the yoke, using Shell Super Duty or an equivalent lithium grease.
9. For an integral overrunning clutch, make sure clutch turns freely in one direction.

Servicing Weasler Modular Friction Clutch (*Cont'd*)

Removing the Driveline

1. Shut off tractor and disengage PTO.
2. Disconnect driveline from PTO shaft.
3. Remove the clamp bolts attaching the clutch to the shredder's input shaft.
4. **NOTE:** The shaft is heavy. Grasp the clutch firmly with both hands and slide off the input shaft.

Rebuilding Friction Pack

Disassembly

1. Position clutch and universal joint assembly on a bench so that end is accessible.
2. Remove the long bolts on the outside of the housing that hold the friction pack together.
3. Remove the plate(s) and all internal components. Leave the yoke/hub intact.
4. Discard friction discs.
5. If rebuilding the overrunning clutch, refer to Rebuilding Overrunning Clutch, page 45, beginning with Step 2.

Inspection

6. Inspect the steel and iron parts for wear, warping, or cracks, and replace if necessary.
7. Inspect the yoke/hub for looseness. If there is more than .03 end play, replace.
8. Clean any rust or dust from the plate surfaces with a wire brush or steel wool.

Assembly

9. Into housing place one new friction disc, then separator plate, then second friction disc.
10. Add the pressure plate so that the flat surface rests on the friction disc. **NOTE:** The tangs on the plate must fall into the reliefs in the housing.
11. Add the disc spring so that its inside diameter contacts the fins of the pressure plate.
12. Assemble the compression plate and all the long bolts. Make sure all nuts rest in their pockets.
13. Tighten all long bolts to 30 lbs.-ft.

Rebuilding Overrunning Clutch

Disassembly

1. Remove the four bolts that secure the friction pack. Remove the friction pack.

2. Using screwdriver and pliers, remove the retaining ring that holds the overrunning clutch together.
3. Slide the collar and washer off the clutch hub, noting the orientation of the collar for reinsertion.
4. Remove and discard the keys and leaf springs.

Inspection

5. Inspect the steel parts for wear and replace if necessary.
6. Inspect the yoke/hub for looseness. If there is more than .03 end play, replace.
7. Using screwdriver, scrape any hardened grease from the overrunning key pockets.

Assembly

8. Using Shell Super Duty grease or equivalent, inject one grease gun pump into each key pocket. Evenly wipe two more pumps over the overrunning surface.
9. Press a new leaf spring into each pocket. The ends should touch the bottom of the pockets.
10. Add new keys. With one hand, hold the two keys in the pockets.
11. Slide the collar onto the hub, orienting collar correctly.
12. Add washer.
13. Install retaining ring.
14. Make sure clutch spins freely and only in correct direction.
15. Reassemble friction pack.

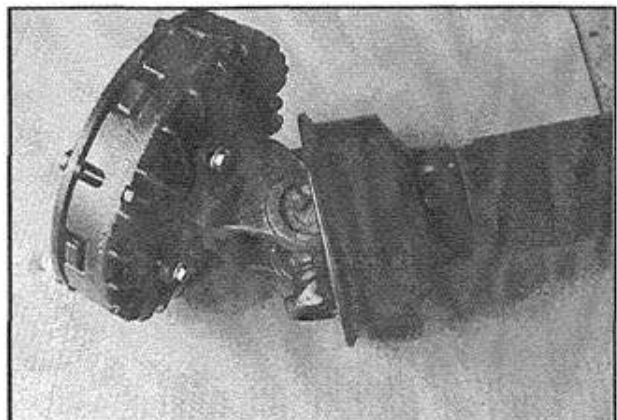

Figure 47. Weasler Modular Friction Clutch Mounting Clutch onto Shredder

1. Mount and bolt the clutch hub onto the shredder input shaft. Make sure shaft and clutch grooves line up.
2. Re-install any shielding that was moved or removed.
3. Run the clutch before using. Refer to Breaking in the Clutch (Run In), page 44.

TROUBLE SHOOTING

The Alloway Center Drive Shredder uses swinging flails to pick up and shred crop residue left in the field. It is a simple and reliable system that requires minimal maintenance.

The following table lists problems, causes, and

solutions that you may encounter. If you encounter a problem that is difficult to solve even after reading through this table, please call your local Alloway dealer. When calling, please have this manual and your unit's serial number ready.

PROBLEM	CAUSE	SOLUTION
Shredder doesn't track	Poor wheel spacing	Set wheels in center of crop rows
	3 Point not set	Set 3-point hitch in non-sway position
	Shredder not level	Level shredder (see Set Operating Height, page 23)
Shredder doesn't follow ground contour	Irrigation furrows not even	Set wheels against seed bed (see Setting Outer Trailing Wheels, page 26)
	3 Point not set	Set 3 point in float position
	Shredder too high	See tractor manual to set Load Sensing hydraulic system
Shredder vibrates	Irrigation furrows not even	Set shredder closer to ground
	Driveline doesn't telescope	Set wheels against seed bed
	Rotor out of balance	Remove, disassemble, and clean telescoping joint
Debris being thrown out from under shredder		Replace damaged or broken flails and flails 180 degree opposite
	Shredder set too low	Check for missing balance weights or rebalance
	Knives excessively worn	Raise shredder
Crop residue left	Rubber shields missing	Replace knives
	Travelling too fast	Replace flaps immediately
	Shredder too high	Slow travel speed
	Improper flails	Lower shredder
Windrowing centers or ends	Crop residue strip left in shredder center	Change flails
	Light, fluffy residue expelled from unit with air flow	Add center cutter or divider

WORKSHEET FOR CONTOUR FLAIL PATTERNS

NOTE: Use the same knives on opposite clips to keep balanced.

30" ROWS

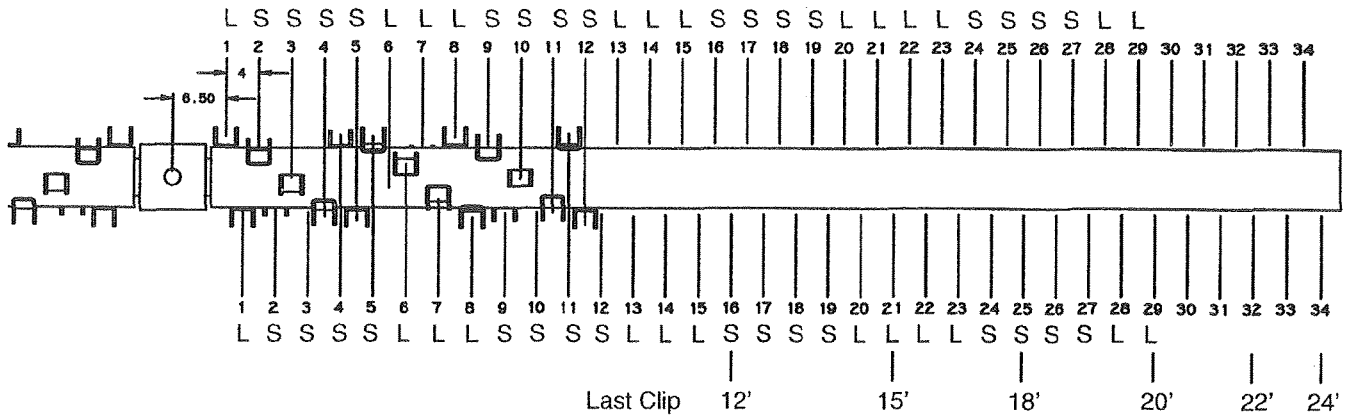

34" ROWS

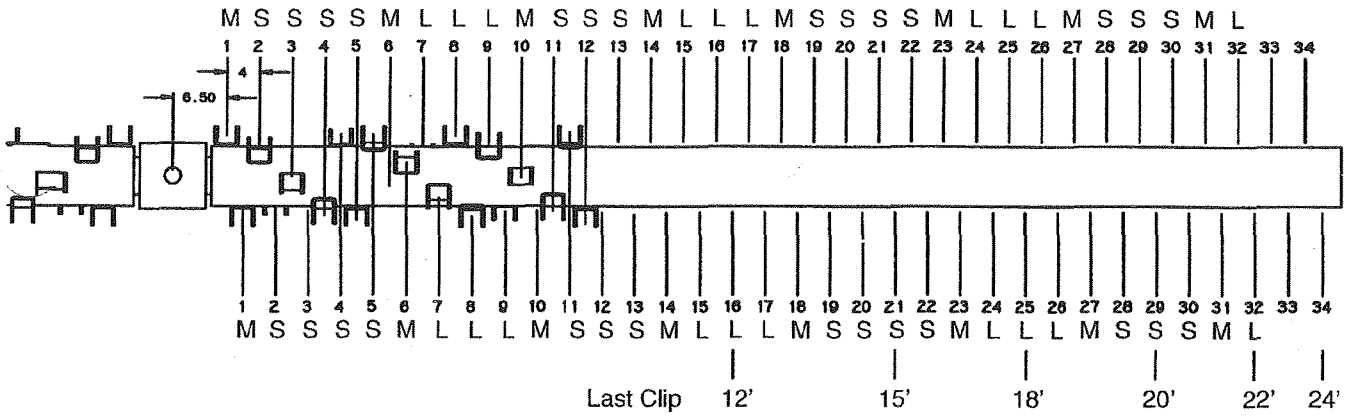

36" ROWS

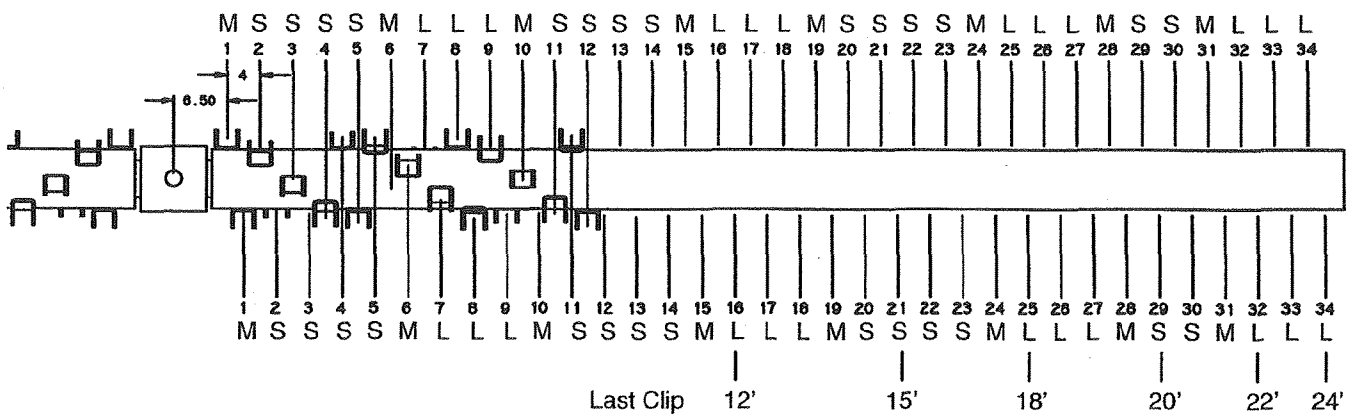

WORKSHEET FOR CONTOUR FLAIL PATTERNS

NOTE: Use the same knives on opposite clips to keep balanced.

38" ROWS

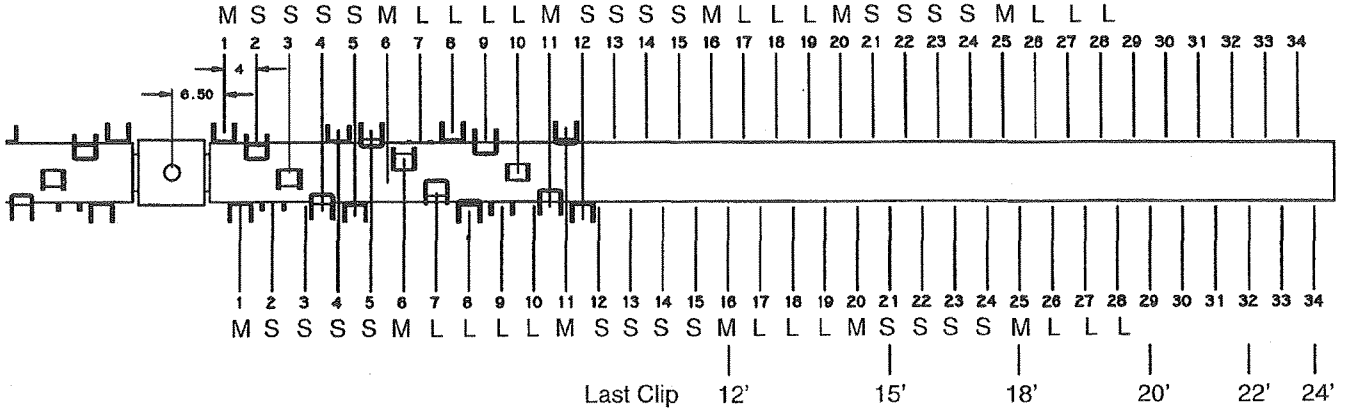

40" ROWS

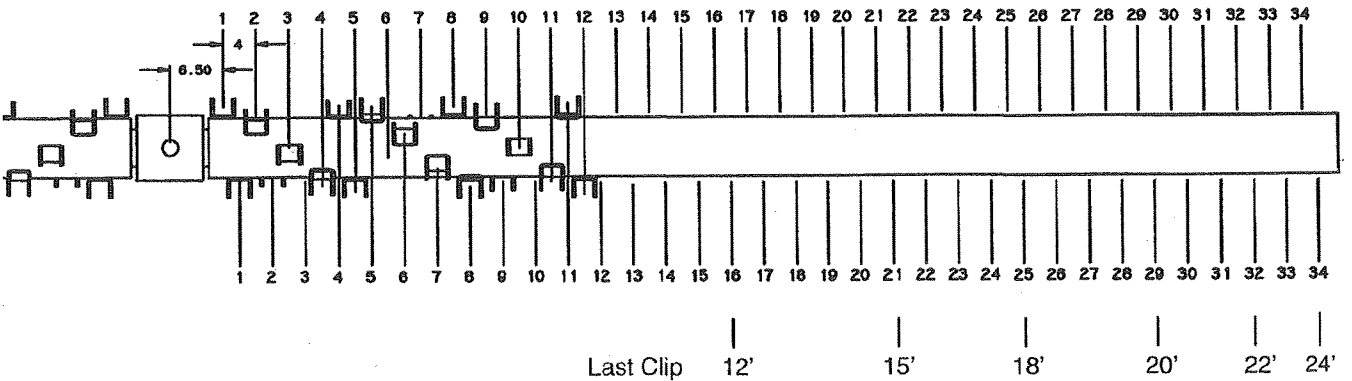
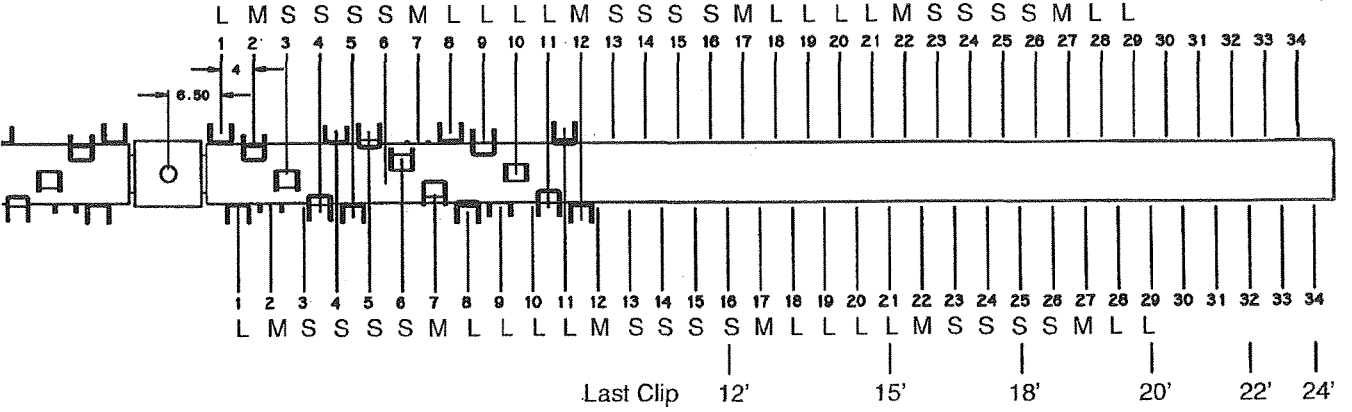

ASSEMBLY

WARNING

- Do not allow bystanders in the area when operating, attaching, removing, assembling, or servicing equipment.
- Do not handle blades with bare hands. Careless or improper handling may result in serious injury.

CAUTION

- Always wear relatively tight and belted clothing to avoid entanglement in moving parts. Wear sturdy, rough-soled work shoes and protective equipment for eyes, hair, hands, hearing, and head; and respirator or filter mask where appropriate.

WARNING

- Keep hands and body away from pressurized lines. Use paper or cardboard, not hands or other body parts to check for leaks. Wear safety goggles. Hydraulic fluid under pressure can easily penetrate skin and will cause serious injury or death.
- Make sure that all operating and service personnel know that if hydraulic fluid penetrates skin, it must be surgically removed as soon as possible by a doctor familiar with this form of injury or gangrene, serious injury, or death will result. **CONTACT A PHYSICIAN IMMEDIATELY IF FLUID ENTERS SKIN OR EYES. DO NOT DELAY.**
- Check that all hardware is properly installed. Always tighten to torque chart specifications unless instructed otherwise in this manual.

CHECK LISTS

Assembly *Continued*

PRE-DELIVERY CHECK LIST (DEALER'S RESPONSIBILITY)	DELIVERY CHECK LIST (DEALER'S RESPONSIBILITY)
<p>Inspect the equipment thoroughly after assembly to ensure it is set up properly before delivering it to the customer.</p> <p>The following check lists are a reminder of points to inspect. Check off each item as it is found satisfactory or after proper adjustment is made.</p> <p><input type="checkbox"/> Check that all safety decals are installed and in good condition. Replace if damaged.</p> <p><input type="checkbox"/> Check that shields and guards are properly installed and in good condition. Replace if damaged.</p> <p><input type="checkbox"/> Check that PTO shaft is properly installed.</p> <p><input type="checkbox"/> Properly attach implement to tractor and make all necessary adjustments.</p> <p><input type="checkbox"/> Check all bolts to be sure they are tight.</p> <p><input type="checkbox"/> Check wheel bolts for proper torque.</p> <p><input type="checkbox"/> Check that all cotter pins and safety pins are properly installed. Replace if damaged.</p> <p><input type="checkbox"/> Check and grease all lubrication points as identified in "Service, lubrication information."</p> <p><input type="checkbox"/> Check the level of gearbox fluids before delivery. Service, if required, as specified in the "Service, lubrication information."</p> <p><input type="checkbox"/> Check that tractor hydraulic reservoir has been serviced and that hydraulic system and all functions have been operated through full cylinder stroke to purge air from system.</p> <p><input type="checkbox"/> After pressurizing and operating all Shredder functions, stop tractor and make sure there are no leaks in the hydraulic system. Follow all safety rules when checking for leaks.</p>	<p><input type="checkbox"/> Show customer how to make adjustments and select proper PTO speed.</p> <p><input type="checkbox"/> Instruct customer how to lubricate and explain importance of lubrication.</p> <p><input type="checkbox"/> Point out the safety decals. Explain their meaning and the need to keep them in place and in good condition. Emphasize the increased safety hazards when instructions are not followed.</p> <p><input type="checkbox"/> Present Operator's Manual and request that customer and all operators read it before operating equipment. Point out the manual safety rules, explain their meanings and emphasize the increased safety hazards that exist when safety rules are not followed.</p> <p><input type="checkbox"/> Show customer how to make sure driveline is properly installed and that spring-activated locking pin or collar slides freely and is seated in groove on tractor PTO shaft.</p> <p><input type="checkbox"/> Show customer the safe, proper procedures to be used when mounting, dismounting, and storing equipment.</p> <p><input type="checkbox"/> Explain to customer that when equipment is transported on a road or highway, safety devices should be used to give adequate warning to operators of other vehicles.</p> <p><input type="checkbox"/> Explain to customer that when equipment is transported on a road or highway, a Slow Moving Vehicle (SMV) sign should be used to provide adequate warning to operators of other vehicles.</p> <p><input type="checkbox"/> Explain to customer that when towing on a public road to comply with all state and local lighting/ marking laws and to use a safety tow chain.</p> <p><input type="checkbox"/> Make customer aware of optional equipment available so that customer can make proper choices as required.</p> <p><input type="checkbox"/> Point out all guards and shields. Explain their importance and the safety hazards that exist when not kept in place and in good condition.</p>

Assembly Continued

WARNING

■ Do not allow bystanders in the area when operating, attaching, removing, assembling, or servicing equipment.

CAUTION

■ Always wear relatively tight and belted clothing to avoid entanglement in moving parts. Wear sturdy, rough-soled work shoes and protective equipment for eyes, hair, hands, hearing, and head; and respirator or filter mask where appropriate.

■ Use a suitable lifting device of sufficient capacity. Use adequate personnel to handle heavy components.

1. Open the crate and cartons containing the attaching components and mounting hardware.
2. Use the packing list to check that all parts have been shipped.

3. Raise the rear of the unit.
4. Place safety stands or large blocks under the frame.
5. Measure the wheel spacing from the center of the unit. Mark the frame.
6. Install the wheel assembly to the mounting tube (Figure 51). **If equipped with caster wheels, verify that there is enough clearance for casters to rotate without hitting each other.** Failure to do so will result in tire damage. Offset struts may be required (see Wheel Assembly parts page 64).
7. Tighten mounting bolts to their specified torque.



Figure 51. Wheel Assembly Installed

3-Point Units:

8. Fasten floating top mast (1) to shredder, using four 1 x 6" hex bolts and top lock nuts as shown in Figure 52. Be sure mast is free to slide forward.
9. Attach one upper 3-point 1 x 5" bolt, bushing, lock washer, and hex nut (2).
 - a. **Category II:** Fasten components in the lower hole in floating top mast.
 - b. **Category III:** Fasten components in the upper hole in floating top mast.
10. Fasten lower 3-point.

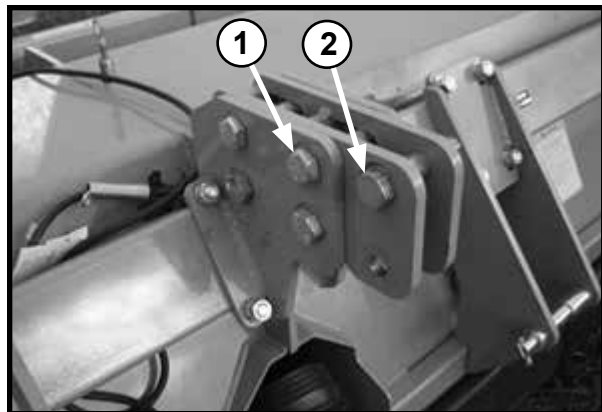

Figure 52. Floating Top Mast Installed

All Units

3. Install PTO driveline by sliding the yoke with the slip clutch over the input shaft (Figure 53).
4. Tighten mounting bolts to its specified torque.
5. Install front parking stands, using pin.

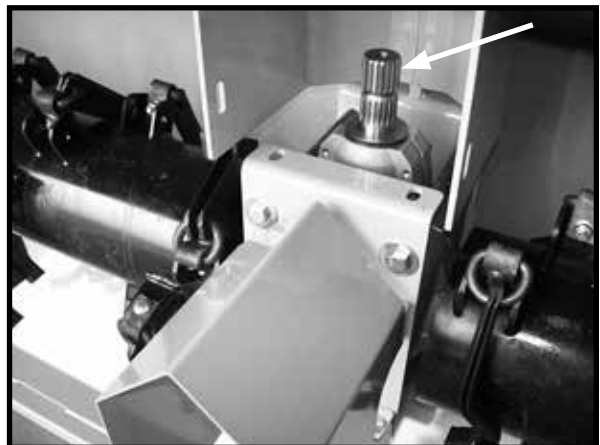

Figure 53. Gearbox Input Shaft

Assembly Continued

Install Pull-Type Hitch (Pull-type units only)

1. Mount hitch to frame using pins and bolts.
2. Install ratchet. Be sure to install retaining pins.
3. Attach Ear Plate to upper tube using U-Bolts and hardware provided.
4. Attach clevis to hitch, using 1-1/4" pin and 3/8 x 3-1/2" cotter pins.
5. Attach tow chain to hitch. See Figure 56 for completed assembly.

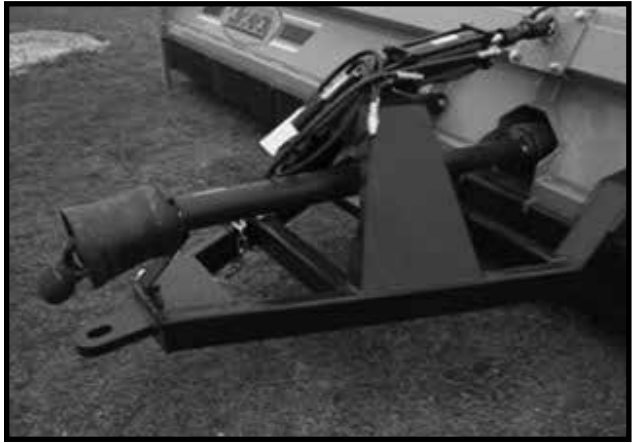

Figure 54. Pull-type Hitch Installed

Install Manual Storage Tube

1. Mount the tube clamp to the shredder side sheet, using two 1/4" self-tapping screws. Mounting holes are located above the bearing plate (see Figure 55).
2. Place the tube in the clamp with the cap facing forward.

NOTE: Keep the Owner's Manual with the shredder at all times.

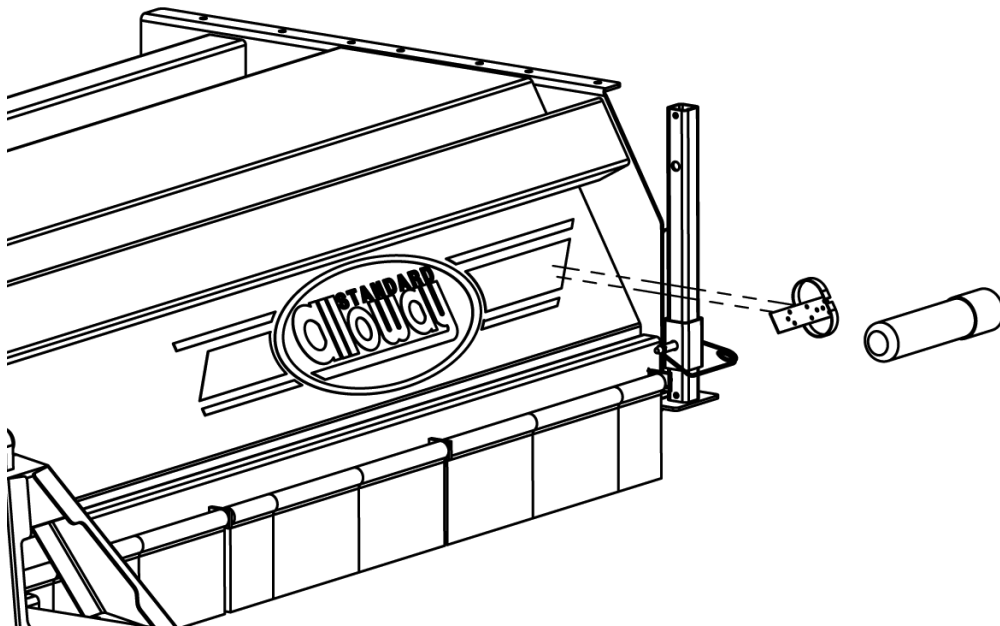

Figure 55. Manual Storage Tube Assembly

Assembly Continued

Safety Light Kit Installation (Non-End Tow)

1. Remove all components from shipping carton. Make sure that all required hardware is included.
2. Attach dual safety lights (Figure 59) to their bases using 1/4 NC x 1" hex bolts, washers and nuts provided. Make sure that light lenses are in the correct position in relation to direction of equipment travel: amber lenses on the outside, red lenses on the inside facing rear of shredder.
3. Plug ends of wiring harness into corresponding plugs of the light units (Note: left side of wishbone harness is labeled "Left").
4. Run wiring harness along top of shredder and secure with enclosed adhesive-backed clamps (5) approximately every two feet.
5. Connect 7-pin connector of wiring harness to tractor and test all light functions before actual use.



Figure 58. Safety Light Kit Installed
(Non-End Tow)

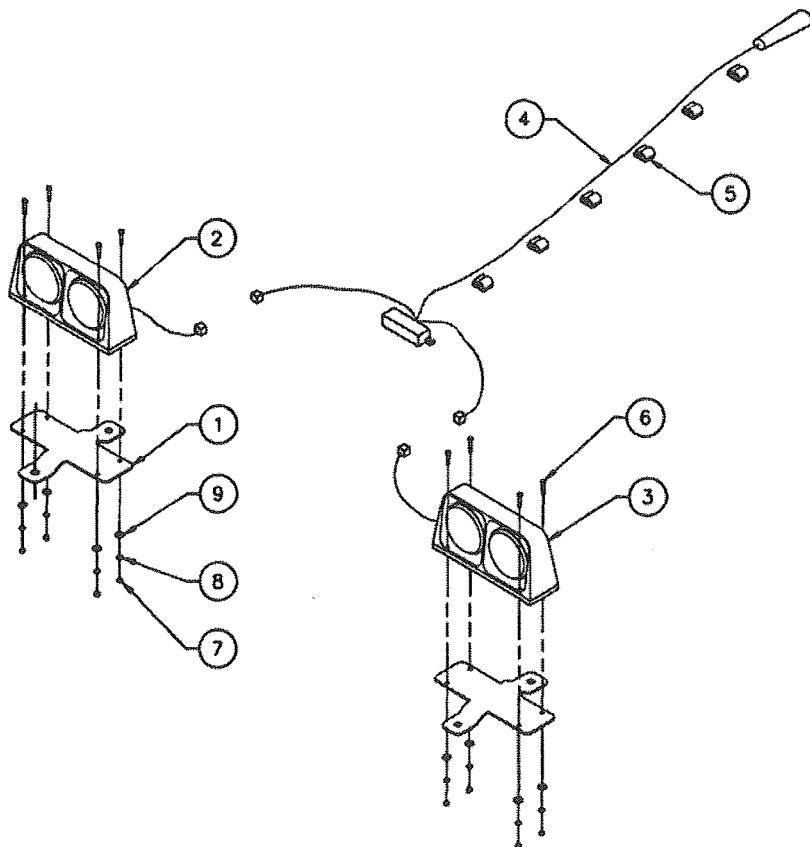

Figure 59. Safety Light Kit Diagram (Non-End Tow)

1. Dual light bracket
2. Dual lamp, 4-pin LH
3. Dual lamp, 4-pin RH
4. Wiring harness
5. Clamp, adhesive-backed
6. 1/4 NCx1" Hex bolt
7. 1/4 NC Hex nut
8. 1/4" Lock washer
9. 1/4" Flat washer

Assembly Continued

Dual Safety Light Assembly (End Tow)

1. Remove all components from shipping carton. Make sure that all required hardware is included.
2. Install light bar on end of shredder that does not have end transport hitch attached. Use 1/2 NC x 1-1/2" hex bolts, washers and nuts (3 each).
3. Attach Slow Moving Vehicle sign (1) to upright bracket using 1/4 NC x 1" hex bolts, washers and nuts (2 each).
4. Attach dual safety lights (5 & 6), Figure 62, to their bases using 1/4 NC x 1" hex bolts, washers and nuts (9,10,11, 12). Make sure that light lenses are in the correct position in relation to direction of equipment travel: amber lenses on the outside, red lenses on the inside facing rear of shredder.

5. Attach lighting module of wiring harness (7) to mount weld (3) using self-drilling Tek screws (17) (2 each). Plug ends of wiring harness into corresponding plugs of the light units (Note: Left side of wishbone harness is labeled "Left").

6. Run wiring harness along top of shredder to front (end transport end) and secure to top with adhesive-backed clamps (8) approximately every 2 feet.

7. Connect 7-pin connector of wiring harness to tractor and test all light functions before actual use.

8. For field use, the tubes will be at their shortest length; during highway transport, they will be at their widest position. Make sure that tubes are locked in place with pins at all times.

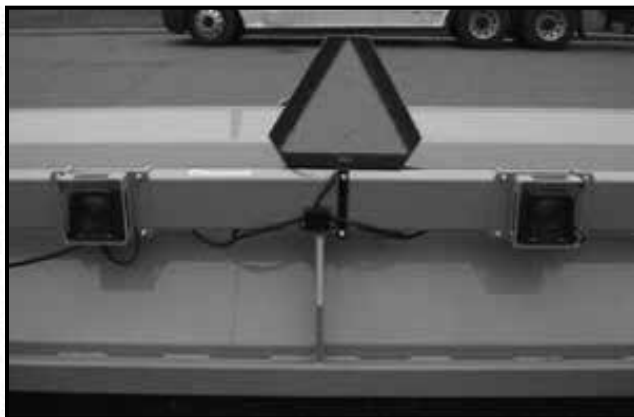
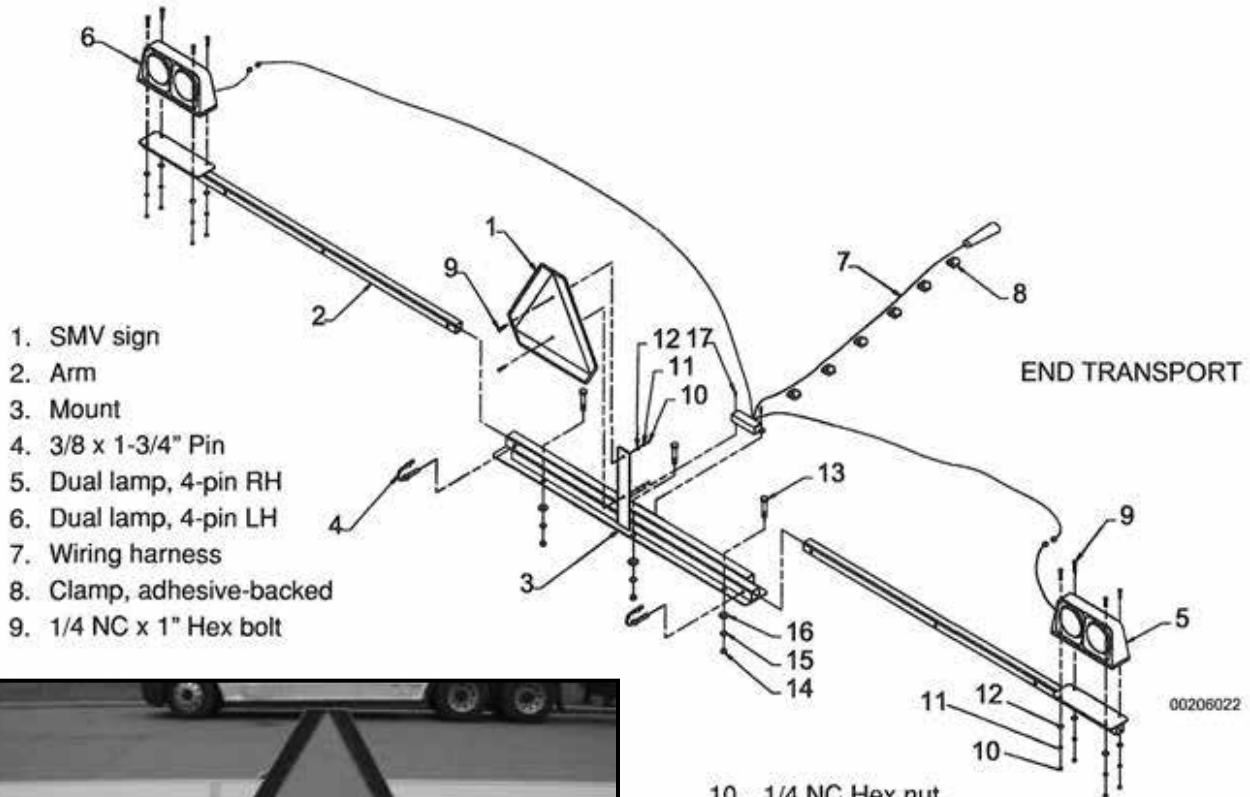

Figure 61. Dual Safety Light Kit Installed

10. 1/4 NC Hex nut
11. 1/4" Lock washer
12. 1/4" Flat washer
13. 1/2 NC x 1-1/2" Hex bolt
14. 1/2 NC Hex nut
15. 1/2" Lock washer
16. 1/2" Flat washer
17. 1/4 x 3/4" Self-drilling Tek screw

Figure 62. Dual Safety Light Kit

NOTES

FLAIL SHREDDER
Center Drive

FRAME COMPONENTS	48-49
FLAIL TUBE COMPONENTS	50-51
3-POINT HITCH COMPONENTS.....	52
PULL TYPE HITCH COMPONENTS.....	53
FRONT CASTER WHEEL COMPONENTS	54-55
REAR CASTER WHEEL COMPONENTS	56-57
RIGID STRUT - DUAL (LARGE WHEELS).....	58-59
RIGID STRUT - DUAL (SMALL WHEELS)	60
LIGHT KIT COMPONENTS	61
WEASLER PULL-TYPE PTO SHAFT WITH TORQ MASTER CLUTCH.....	62
WEASLER 2-POINT & 3-POINT PTO SHAFT WITH TORQ MASTER CLUTCH.....	63
WEASLER TORQ MASTER CLUTCH COMPONENTS.....	64
CENTER DRIVE GEARBOX COMPONENTS.....	65

CENTER DRIVE FLAIL SHREDDER FRAME COMPONENTS

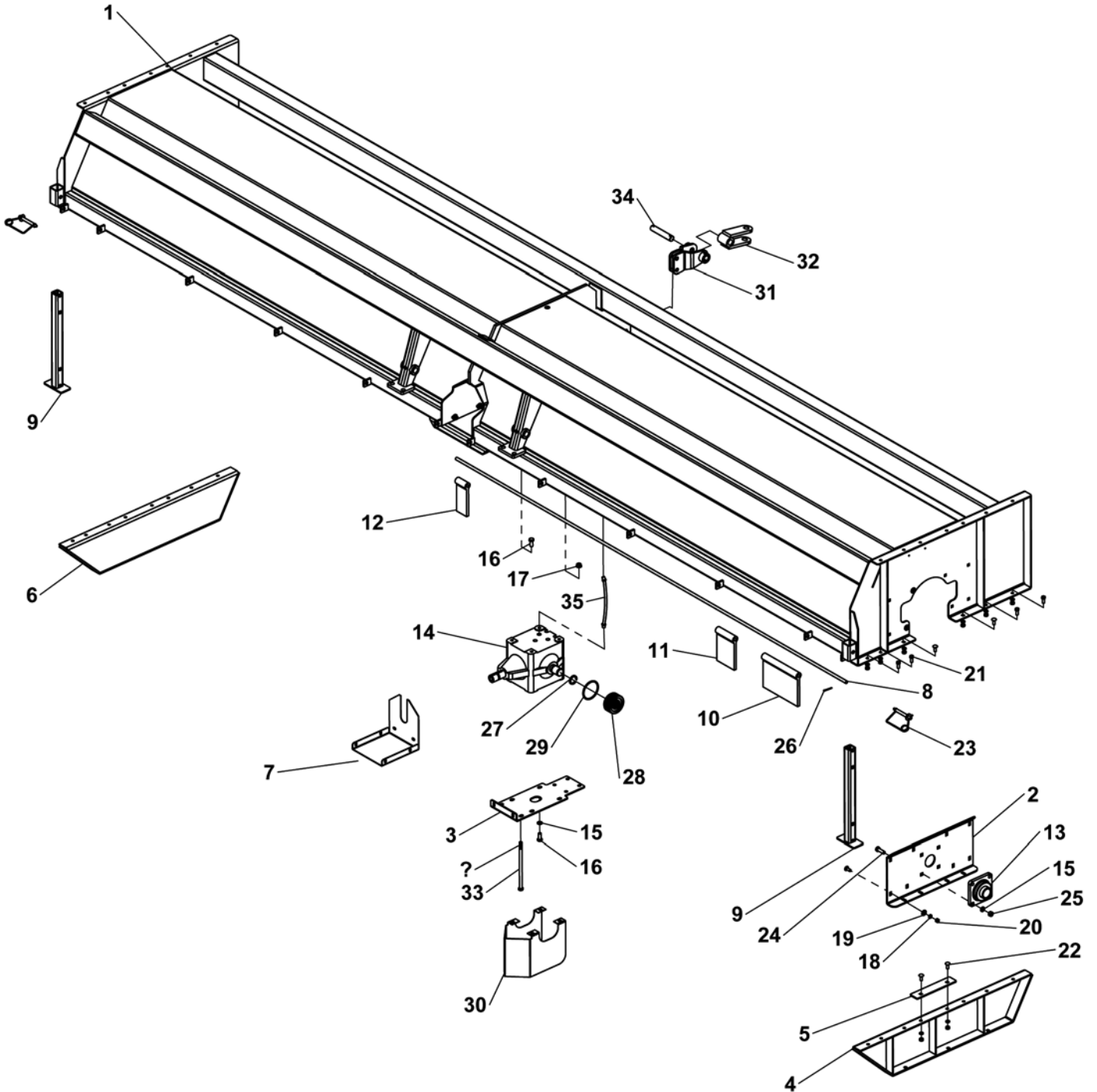

CENTER DRIVE FLAIL SHREDDER FRAME COMPONENTS

ITEM NO.	PART NUMBER	DESCRIPTION	QTY.
1	507-2-0062	12' SHREDDER BODY WELD - GEAR DRIVE	1
	507-2-0063	15' SHREDDER BODY WELD - GEAR DRIVE	
	507-2-0064	18' SHREDDER BODY WELD - GEAR DRIVE	
	507-2-0065	20' SHREDDER BODY WELD - GEAR DRIVE	
	507-2-0066	22' SHREDDER BODY WELD - GEAR DRIVE	
	507-2-0067	25' SHREDDER BODY WELD - GEAR DRIVE	
	507-2-0068	27' SHREDDER BODY WELD - GEAR DRIVE	
	507-2-0069	30' SHREDDER BODY WELD - GEAR DRIVE	
2	507-3-0023	BEARING MOUNTING PLATE	2
3	507-3-0120	BOTTOM GEARBOX PLATE	1
4	507-2-0018	SKID PLATE WELD-LH	1
5	507-3-0046	SPACER PLATE - SKID	2
6	507-2-0019	SKID PLATE WELD - RH	1
7	507-3-0121	CLUTCH SHIELD	1
8	507-3-0220	FLAP ROD - 12'	2
	507-3-0221	FLAP ROD - 15'	
	507-3-0222	FLAP ROD - 18'	
	507-3-0054	FLAP ROD - 20'	
	507-3-0128	FLAP ROD - 22'	
	507-3-0196	FLAP ROD - 25'	
	507-3-0209	FLAP ROD - 27'	
	507-3-0223	FLAP ROD - 30'	
9	507-2-0021	PARKING STAND WELD	2
10	505-3-1089	FLAP SHIELD 12"	18
11	505-3-1097	FLAP SHIELD 6"	7
12	505-3-0868	FLAP SHIELD 3-1/2"	1
13	901-01311	BEARING - UCF 211-35 2.19 4-BOLT	2
14	903-15566	G-BOX - SUPERIOR MODEL R800	1
15	900-11015	WASHER, LOCK, 5/8	20
16	900-01341	HEX BOLT 5/8 NC X 1-1/2 NC GR5 ZP	12
17	900-06145	5/8 WHIZ NUT	4
18	900-11013	WASHER, LOCK 1/2	38
19	900-11035	1/2 FLAT WASHER	28
20	900-06009	NUT HEX 1/2 UNC	38
21	900-01223	1/2 NC X 1-1/2 HEX BOLT GR 5	14
22	900-01750	CARRIAGE BOLT 1/2 NC X 1 1/4 GD 5 ZP	24
23	900-42054	LOCK UP PIN	2
24	900-01345	5/8" X 2 NC HEX BOLT	8
25	900-06013	NUT HEX 5/8 UNC	8
26	900-23043	3/16 X 1 1/2 COTTER PIN	2
27	900-39030	RETAINING RING 600 SERIES	4
28	500-3-0338	COUPLER	2
29	901-09126	O-RING, FLAIL COUPLER	2
30	507-3-0157	CENTER DIVIDER PLATE - MODEL 800 GEARBOX (Optional)	1
31	507-2-0016	REAR HITCH BASE WELD	1
32	507-2-0017	REAR HITCH WELD	1
33	900-01393	HEX BOLT- 5/8 X 12 UNC ZP	1
34	507-3-0042	PIN - REAR HITCH	1
35	905-19224	DIPSTICK TUBE, FLEXIBLE R800	1

FLAIL TUBE COMPONENTS

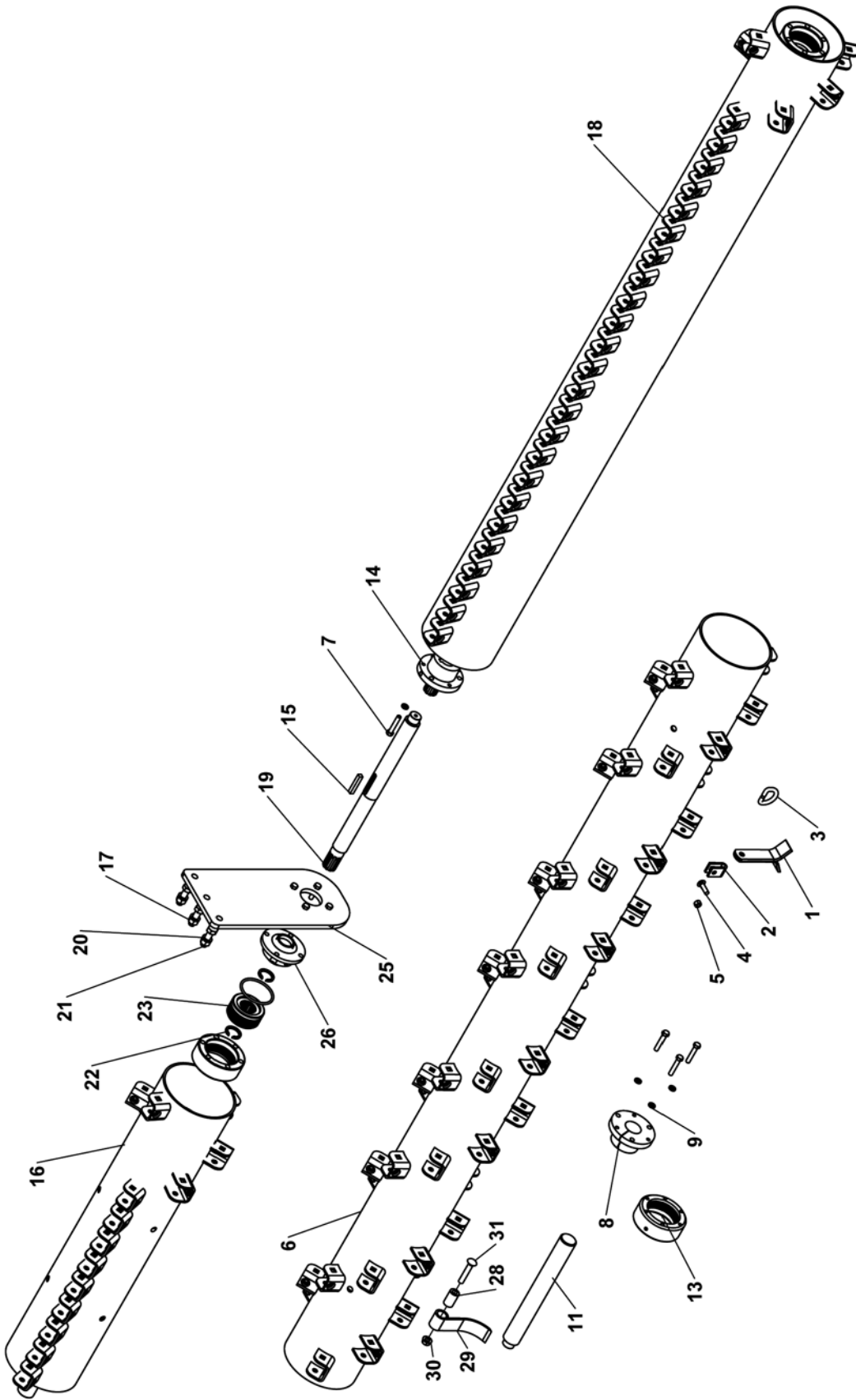

FLAIL TUBE COMPONENTS

ITEM NO.	PART NUMBER	DESCRIPTION	QTY.
1	505-3-0001	STEEL L-KNIFE LONG	A/R
2	507-3-0109	D-RING CLIP	A/R
3	505-3-0008	D-RING	A/R
4	900-01752	CARRIAGE BOLT 1/2 NC X 1 3/4 GD 5 ZP	A/R
5	900-06504	NUT, HEX 1/2 NC TOP LOCK NUT ZP	A/R
6	507-2-0131	12' FLAIL TUBE WELDMENT - LH	1
	507-2-0130	12' FLAIL TUBE WELDMENT - RH	1
	507-2-0133	15' FLAIL TUBE WELDMENT - LH	
	507-2-0132	15' FLAIL TUBE WELDMENT - RH	
	507-2-0135	18' FLAIL TUBE WELDMENT - LH	
	507-2-0134	18' FLAIL TUBE WELDMENT - RH	
	507-2-0075	20' FLAIL TUBE WELDMENT - LH	
	507-2-0076	20' FLAIL TUBE WELDMENT - RH	
	507-2-0079	22' FLAIL TUBE WELDMENT - LH	
	507-2-0080	22' FLAIL TUBE WELDMENT - RH	
	507-2-0114	25' FLAIL TUBE WELDMENT - LH	
	507-2-0113	25' FLAIL TUBE WELDMENT - RH	
7	900-02526	BOLT HEX 1/2 X 2-3/4 GR 5	6
8	903-08420	TYPE E HUB 2-3/16 BORE	1
9	900-11013	WASHER, LOCK 1/2	5
10	507-2-0004	INNER DONUT WELD - 10" FLAIL TUBE	1
11	507-3-0012	STUB SHAFT - 2.19 DIA	1
12	507-3-0013	MOUNTING HUB - TYPE E HUB	1
13	500-3-0345	DRIVE SLEEVE, OUTER	2
14	500-3-1060	HUB 2" TYPE "E" W/KW	1
15	100-3-3331	KEY - 1/2 X 1/2 X 3	1
16	507-2-0118	FLAIL TUBE WELDMENT - 27' OUTER LH	1
	507-2-0119	FLAIL TUBE WELDMENT - 27' OUTER RH	
	507-2-0137	FLAIL TUBE WELDMENT - 30' OUTER LH	
	507-2-0136	FLAIL TUBE WELDMENT - 30' OUTER RH	
17	900-06015	HEX NUT - 3/4 NC	3
18	507-2-0125	INNER FLAIL TUBE WELDMENT - 27' & 30' LH	1
	507-2-0126	INNER FLAIL TUBE WELDMENT - 27' & 30' RH	1
19	500-3-0785	SHAFT - CENTER	1
20	900-11017	3/4 LOCK WASHER	3
21	900-01407	3/4-10 X 2-1/2 HEX BOLT ZP	3
22	900-39030	RETAINING RING 600 SERIES	4
23	500-3-0338	COUPLER	2
24	901-09126	O-RING, FLAIL COUPLER	2
25	507-2-0121	HANGER PLATE WELD	1
26	500-2-0598	BEARING ASSEMBLY, ROUND TEROG	1
27	900-06009	NUT HEX 1/2 UNC	1
28	505-3-0405	BUSHING, CUP KNIFE	A/R
29	505-3-0004	CUP KNIFE - 7"	A/R
	505-3-0006	CUP KNIFE - 9"	
	505-3-0005	CUP KNIFE - 11"	
30	900-06145	NUT, 5/8 WHIZ	A/R
31	900-01792	BOLT, CARRIAGE 5/8-11 x 3.50	A/R

3-POINT HITCH COMPONENTS

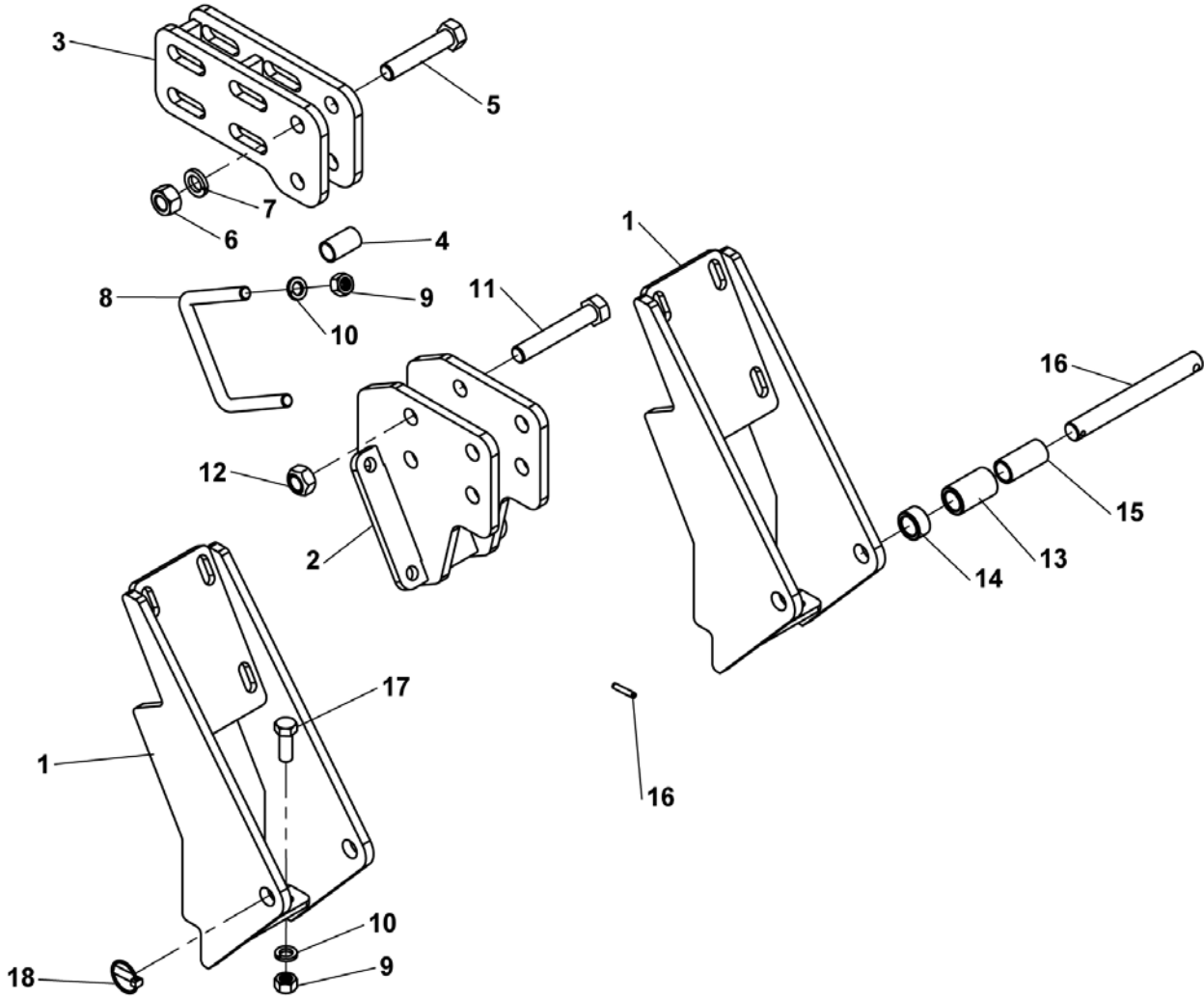

NS = Not Shown
AR = As Required

ITEM NO.	PART NUMBER	DESCRIPTION	QTY.
1	507-2-0013	LOWER 3-PT HITCH WELD	2
2	507-2-0015	UPPER 3-PT MOUNT	1
3	507-2-0020	UPPER MAST PLATE WELD	1
4	200-3-0151	MAST SPACER BUSHING	1
5	900-01531	HEX BOLT - 1NC X 5 GR5 ZP	1
6	900-06019	1-8 HEX NUT	1
7	900-11021	LOCK WASHER - 1	1
8	200-3-0024	U-BOLT 3/4 X 6 X 5.5 X 1.5	6
9	900-06015	HEX NUT - 3/4 NC	AR
10	900-11017	3/4 LOCK WASHER	AR
11	900-01535	HEX BOLT - 1NC X 6 GR5 ZP	4
12	900-06514	1-8 TOP LOCK NUT	4
13	200-3-0959	SPACER - LOWER 3 PT HITCH	2
14	200-3-0960	SPACER - LOWER 3 PT HITCH	2
15	200-3-0961	BUSHING - LOWER 3 PT	2
16	200-2-0553	PIN ASSY - LOWER 3 PT HITCH	2
17	900-01403	HEX BOLT - 3/4NC X 2 GR5 ZP	4
18	900-25012	KLICK PIN - 7/16 X 2	2
	507-1-0002	CARTON - 3 PT HITCH	

PULL TYPE HITCH COMPONENTS

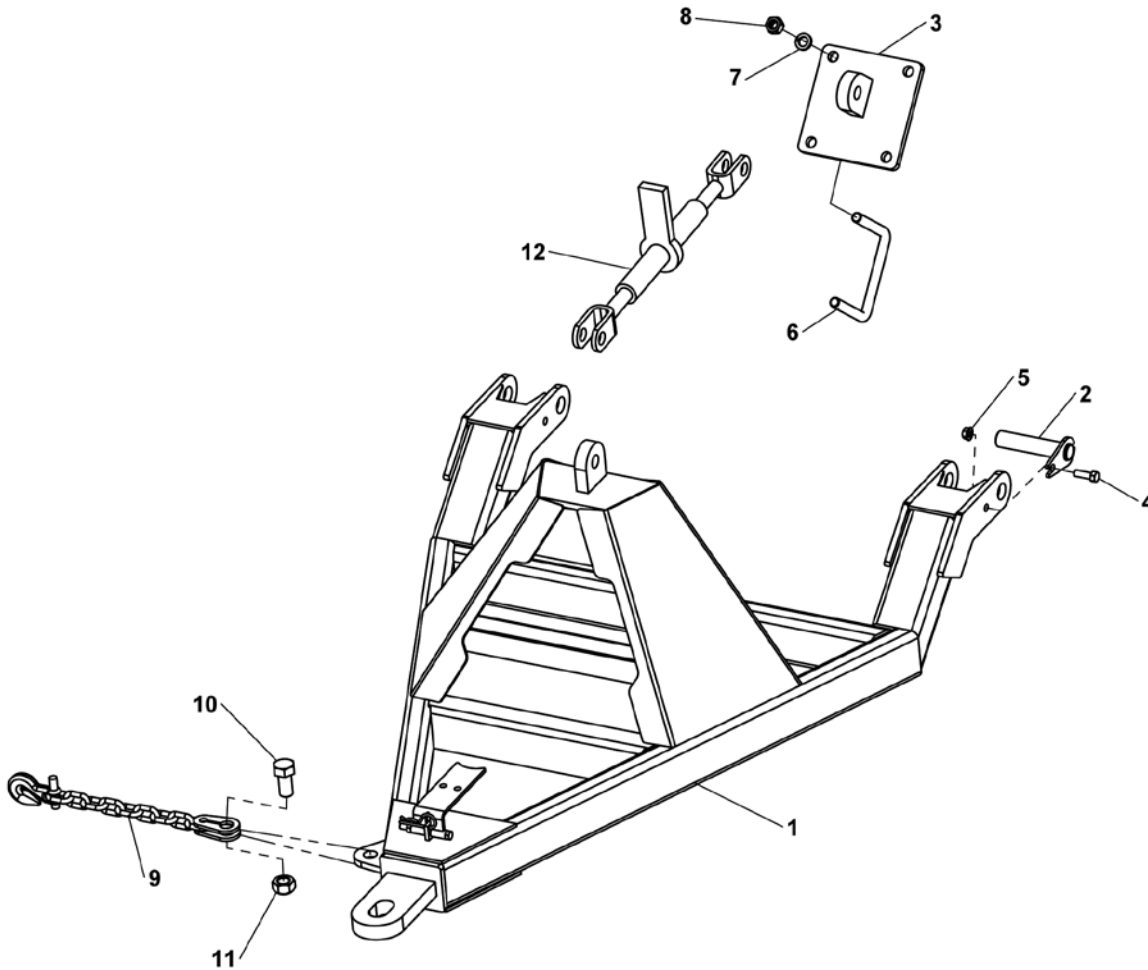

ITEM NO.	PART NUMBER	DESCRIPTION	QTY.
1	507-2-0027	HITCH WELD - PULL TYPE	1
2	500-2-0684	1-1/4" PIN WELDMENT	2
3	507-2-0033	TOP EAR WELD	1
4	900-01225	1/2 NC X 1-1/2 HEX BOLT GR 5	2
5	900-06143	1/2 NC SPIRALOCK NUT ZP GR5	2
6	200-3-0024	U-BOLT 3/4 X 6 X 5.5 X 1.5	2
7	900-11017	3/4 LOCK WASHER	4
8	900-06015	HEX NUT - 3/4 NC	4
9	905-07123	TOW CHAIN SAFETY 21,000 LB	1
10	900-01511	HEX BOLT 1 NC X 2 GD 5 ZP	1
11	900-06514	1-8 TOP LOCK NUT	1
12	905-23014	RATCHET JACK HEAVY DUTY	1
	507-1-0003	CARTON - PULL TYPE HITCH	

FRONT CASTER WHEEL COMPONENTS

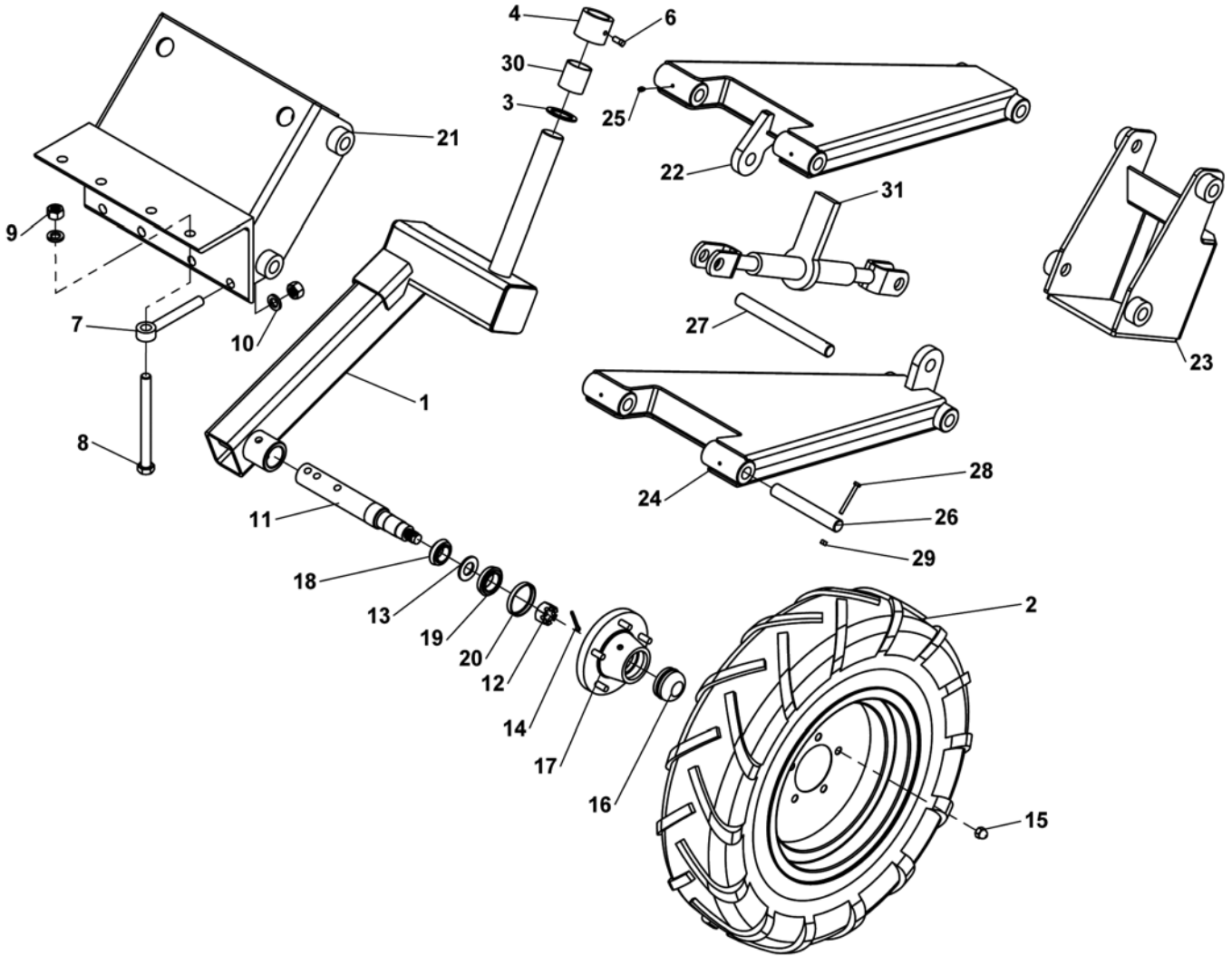

FRONT CASTER WHEEL COMPONENTS

ITEM NO.	PART NUMBER	DESCRIPTION	QTY.
1	507-2-0103	LOWER CASTER WELDMENT	1
2	500-2-0157	TRACTION TIRE ASSY RH	1
	500-2-0158	TRACTION TIRE ASSY LH	
3	901-01259	THRUST BEARING	1
4	500-3-0928	COLLAR	1
5	900-06270	3/8" JAM NUT	1
6	900-16031	3/8-16 X 3/4" SQUARE HEAD SET SCREW	1
7	900-03463	3/4-10 EYE BOLT	4
8	900-01437	HEX BOLT - 3/4 NC X 8-1/2 GR5	4
9	900-06015	HEX NUT - 3/4 NC	8
10	900-11017	3/4 LOCK WASHER	8
11	500-3-0136	SPINDLE	1
12	900-06062	1-14 HEX SLOTTED NUT	1
13	905-09068	WASHER 1" SAE	1
14	900-23045	3/16 X 2 COTTER PIN	1
15	905-09011	WHEEL NUT	5
16	905-09009	DUST CAP	1
17	905-09003	5 BOLT HUB	1
18	901-01015	BEARING CONE	1
19	901-01023	BEARING CONE	1
20	901-09002	BORE SEAL	1
21	507-2-0105	FRONT CASTER MOUNT WELD	1
22	507-2-0101	PARALLEL LINK ARM	1
23	507-2-0028	UPPER CASTER WELDMENT	1
24	507-2-0102	LOWER PARALLEL LINK ARM	1
25	905-15024	ZERK 1/4-28 UNF STRAIGHT	7
26	507-3-0179	PIN - CASTER WHEEL LINKAGE	4
27	507-3-0180	LONG PIN - CASTER WHEEL LINKAGE	2
28	900-01021	.25 UNC X 2 1/2 BOLT	6
29	900-06496	1/4-20 TOP LOCK HEX NUT	6
30	901-01261	OILITE BUSHING	2
31	905-23014	RATCHET JACK HEAVY DUTY	1
	507-2-0106	FRONT CASTER WHEEL ASSY	

REAR CASTER WHEEL COMPONENTS

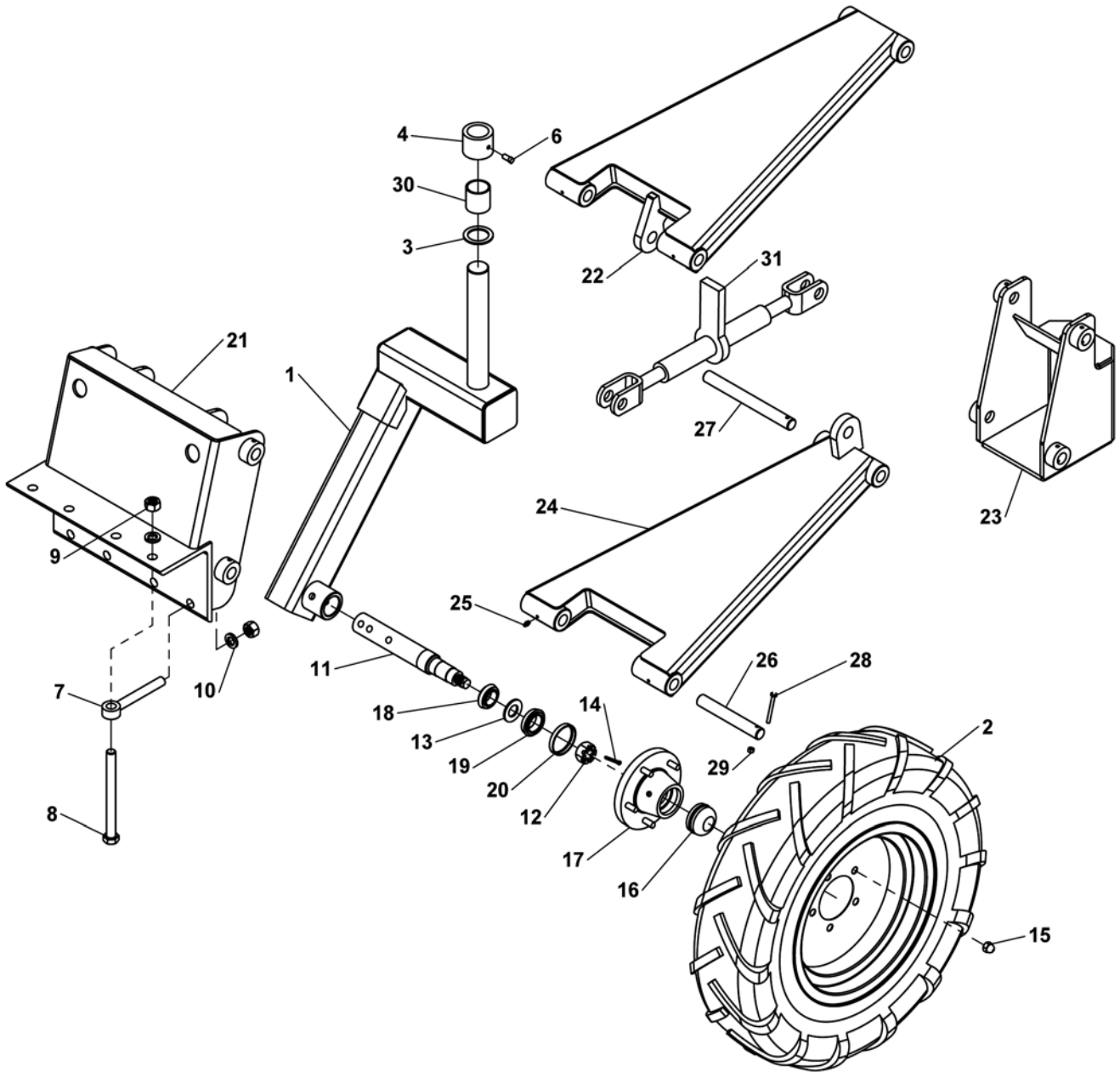

REAR CASTER WHEEL COMPONENTS

ITEM NO.	PART NUMBER	DESCRIPTION	QTY.
1	507-2-0103	LOWER CASTER WELDMENT	1
2	500-2-0157	TRACTION TIRE ASSY RH	1
3	901-01259	THRUST BEARING	1
4	500-3-0928	COLLAR	1
5	900-06270	3/8" JAM NUT	1
6	900-16031	3/8-16 X 3/4" SQUARE HEAD SET SCREW	1
7	900-03463	3/4-10 EYE BOLT	4
8	900-01437	HEX BOLT - 3/4 NC X 8-1/2 GR5	4
9	900-06015	HEX NUT - 3/4 NC	8
10	900-11017	3/4 LOCK WASHER	8
11	500-3-0136	SPINDLE	1
12	900-06062	1-14 HEX SLOTTED NUT	1
13	905-09068	WASHER 1" SAE	1
14	900-23045	3/16 X 2 COTTER PIN	1
15	905-09011	WHEEL NUT	5
16	905-09009	DUST CAP	1
17	905-09003	5 BOLT HUB	1
18	901-01015	BEARING CONE	1
19	901-01023	BEARING CONE	1
20	901-09002	BORE SEAL	1
21	507-2-0099	REAR CASTER MOUNT WELD	1
22	507-2-0101	PARALLEL LINK ARM	1
23	507-2-0028	UPPER CASTER WELDMENT	1
24	507-2-0102	LOWER PARALLEL LINK ARM	1
25	905-15024	ZERK 1/4-28 UNF STRAIGHT	7
26	507-3-0179	PIN - CASTER WHEEL LINKAGE	4
27	507-3-0180	LONG PIN - CASTER WHEEL LINKAGE	2
28	900-01021	.25 UNC X 2 1/2 BOLT	6
29	900-06496	1/4-20 TOP LOCK HEX NUT	6
30	901-01261	OILITE BUSHING	2
31	905-23014	RATCHET JACK HEAVY DUTY	1
	507-2-0107	REAR CASTER WHEEL ASSY	

RIGID STRUT - DUAL (LARGE WHEELS)

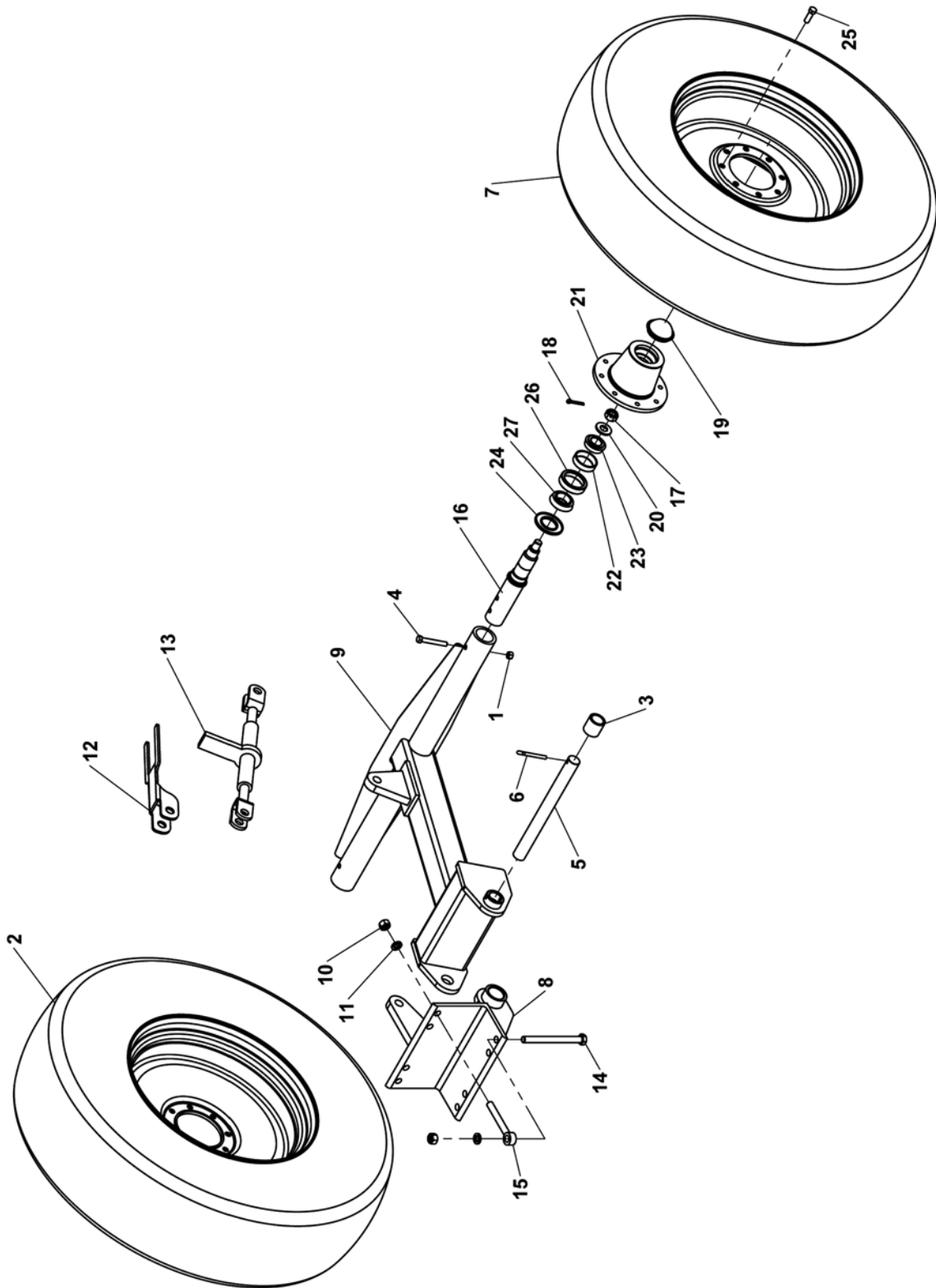

RIGID STRUT - DUAL (LARGE WHEELS)

ITEM NO.	PART NUMBER	DESCRIPTION	QTY.
1	900-06504	NUT HEX 1/2 NC TOP LOCK ZP	2
2	700-2-0168	TIRE AND RIM ASSY RH	1
3	500-3-1151	BUSHING	2
4	900-01241	1/2-13 X 3.5" HEX BOLT	2
5	500-3-1328	PIN, PIVOT	1
6	900-23084	3/8 X 3-1/2 COTTER PIN	1
7	700-2-0167	TIRE AND RIM ASSY LH	1
8	507-2-0032	MOUNTING ANGLE WELDMENT	1
9	500-2-0998	REAR STRUT WELDMENT - DUAL 22"	1
	500-2-1023	REAR STRUT WELDMENT - DUAL 30"	
10	900-06015	HEX NUT - 3/4 NC	8
11	900-11017	3/4 LOCK WASHER	8
12	500-3-2202	RACHET JACK SUPPORT BRACKET	1
13	905-23014	RATCHET JACK HEAVY DUTY	1
14	900-01437	HEX BOLT - 3/4 NC X 8-1/2 GR5	4
15	900-03463	3/4-10 EYE BOLT	4
16	700-3-0143	SPINDLE REAR STRUT	2
17	900-06060	SLOTTED HEX NUT 7/8 -14 NF	2
18	900-23064	COTTER PIN - 1/4 X 2	2
19	905-09135	HUB CAP	2
20	905-09067	WASHER, FLAT	2
21	905-09136	HUB WITH CUPS	2
22	901-01324	BEARING TIMKEN 25821	2
23	901-01326	BEARING TIMKEN 25877	2
24	901-09215	SEAL	2
25	905-09039	WHEEL BOLT 9/16-18 X 1-11/16	16
26	901-01152	BEARING TIMKEN 25520	2
27	901-01325	BEARING TIMKEN 25590	2
	507-2-0031	REAR STRUT ASSY - DUAL W/ RATCHET JACK 44" WHEELS	

RIGID STRUT - DUAL (SMALL WHEELS)

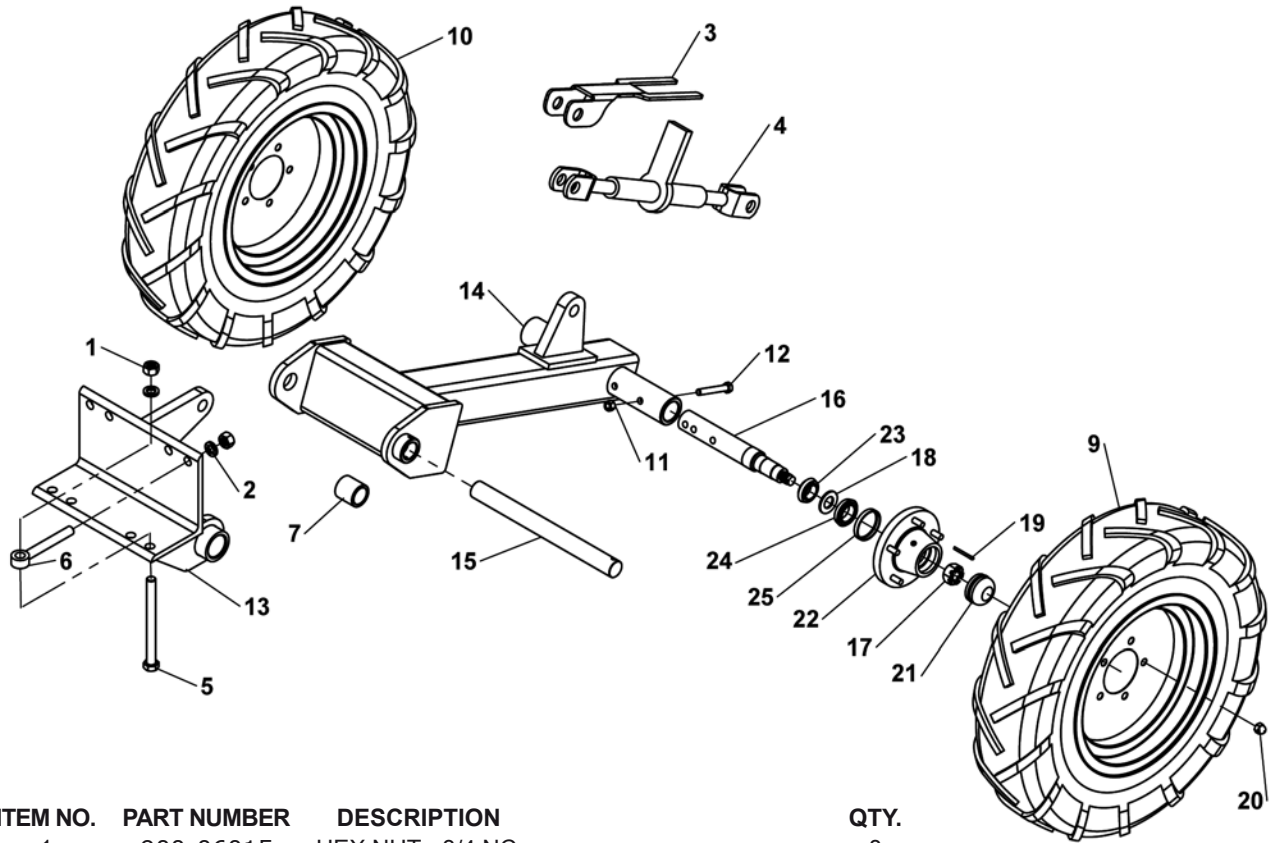

ITEM NO.	PART NUMBER	DESCRIPTION	QTY.
1	900-06015	HEX NUT - 3/4 NC	8
2	900-11017	3/4 LOCK WASHER	8
3	500-3-2202	RATCHET JACK SUPPORT BRACKET	1
4	905-23014	RATCHET JACK HEAVY DUTY	1
5	900-01437	HEX BOLT - 3/4 NC X 8-1/2 GR5	4
6	900-03463	3/4-10 EYE BOLT	4
7	500-3-1151	BUSHING	2
8	500-2-0161	HUB & SPINDLE ASSEMBLY	1
9	500-2-0157	TRACTION TIRE ASSY RH	1
10	500-2-0158	TRACTION TIRE ASSY LH	1
11	900-06504	NUT HEX 1/2 NC TOP LOCK ZP	2
12	900-01241	1/2-13 X 3.5" HEX BOLT	2
13	507-2-0032	MOUNTING ANGLE WELDMENT	1
14	507-2-0083	REAR STRUT WELD - DUAL 22"	1
	507-2-0093	REAR STRUT WELD - DUAL 30"	
15	500-3-1328	PIN, PIVOT	1
16	500-3-0136	SPINDLE	2
17	900-06062	1-14 HEX SLOTTED NUT	2
18	905-09068	WASHER 1" SAE	2
19	900-23045	3/16 X 2 COTTER PIN	2
20	905-09011	WHEEL NUT	10
21	905-09009	DUST CAP	2
22	905-09003	5 BOLT HUB	2
23	901-01015	BEARING CONE	2
24	901-01023	BEARING CONE	2
25	901-09002	BORE SEAL	2
	507-2-0082	REAR STRUT ASSY - DUAL W/RATCHET JACK	

LIGHT KIT COMPONENTS

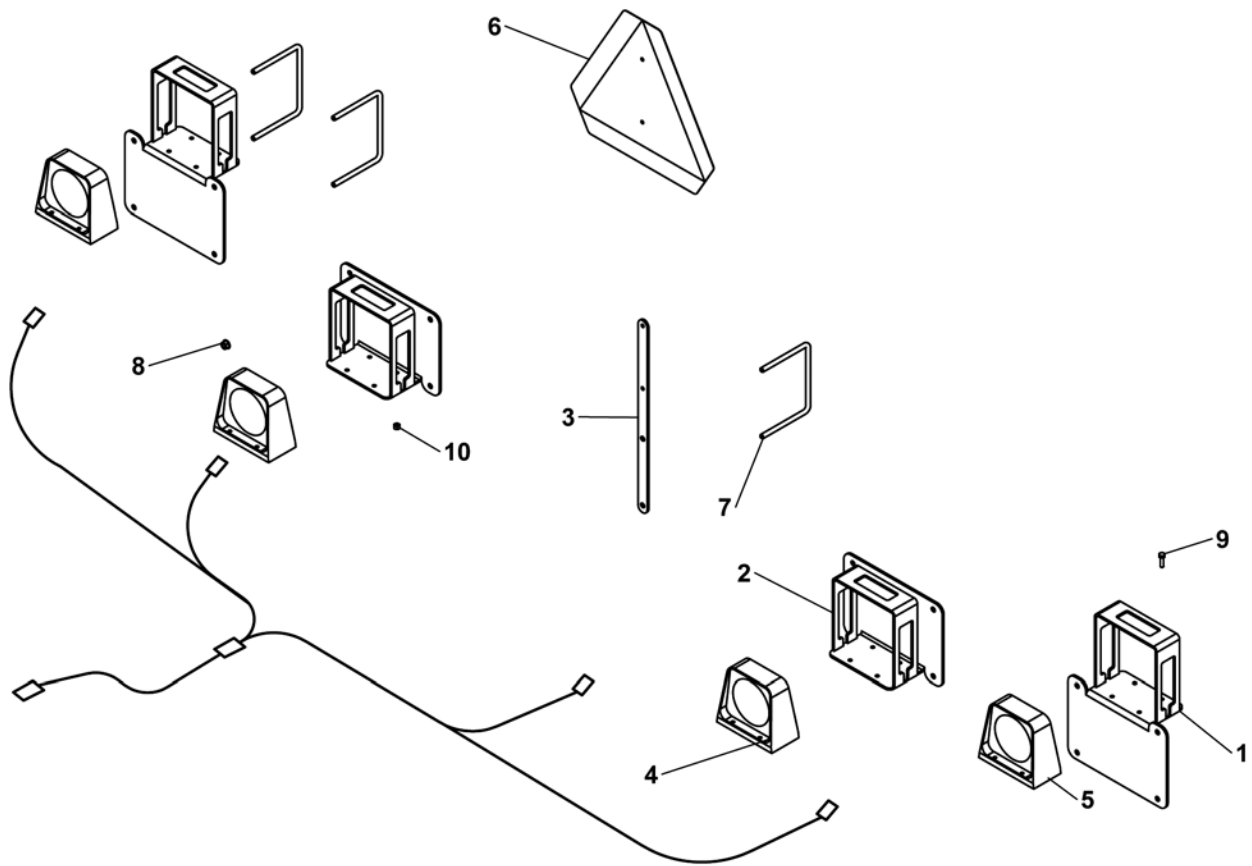

ITEM NO.	PART NUMBER	DESCRIPTION	QTY.
1	507-2-0108	AMBER LIGHT BRACKET	2
2	500-2-0930	RED LIGHT BRACKET	2
3	500-3-2091	SMV MOUNT	1
4	904-01155	RED LAMP	2
5	904-01154	AMBER LAMP	2
6	500-3-1696	SMV SIGN	1
7	900-35000	U-BOLT 3/8 X 6 X 5 X 1.5	9
8	900-06005	3/8 NC FLANGED WHIZ NUT	18
9	900-01005	1/4-20 X 1 ZP HEX BOLT	16
10	900-06496	1/4-20 TOP LOCK HEX NUT	16
	507-1-0019	CARTON - LIGHT KIT STD SHREDDER	

WEASLER PULL-TYPE PTO SHAFT WITH TORQ MASTER CLUTCH

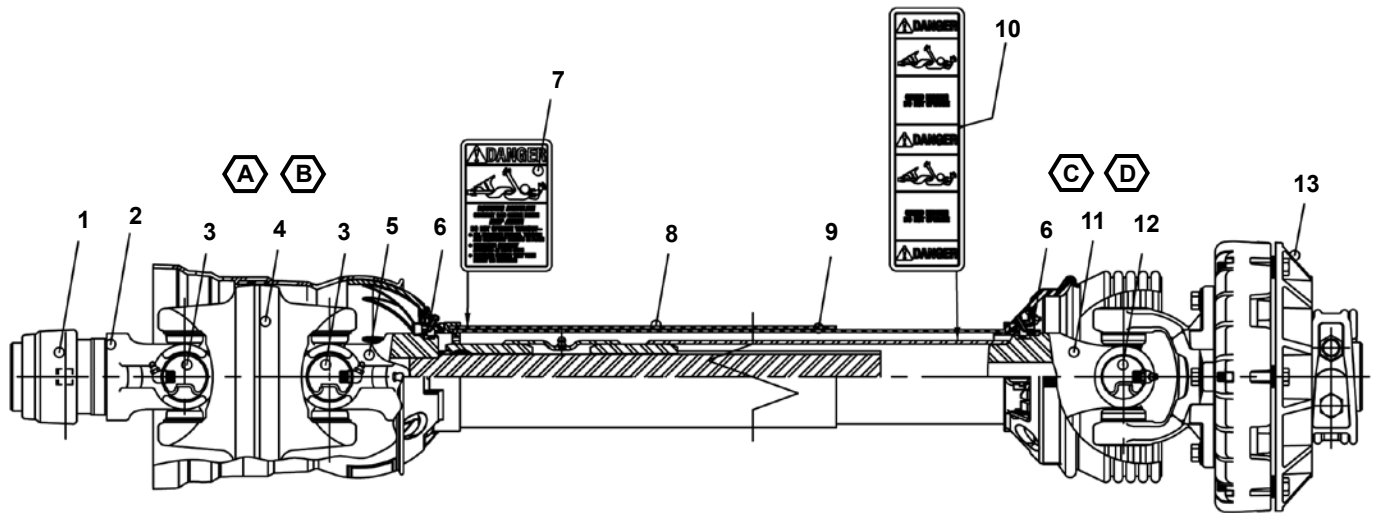

ITEM NO.	PART	DESCRIPTION	QTY
1	903-18106	Safety Slide Lock Repair Kit 1-3/8"	1
		-OR-	
	903-17772	Safety Slide Lock Repair Kit 1-3/4"	1
2	903-17733	Safety Slide Lock Yoke Assembly 1-3/8"	1
		-OR-	
	903-18121	Safety Slide Lock Yoke Assembly 1-3/4"	1
3	903-17737	CAT 6 Cross & Bearing Kit	2
4	903-17739	Center Housing Assembly	1
5	903-17908	Yoke & Shaft	1
6	903-17774	Nylon Repair Kit	2
7	903-17455	Safety Sign	1
8	903-18057	Outer Guard	1
9	903-17910	Inner Guard	1
10	903-17456	Safety Sign	1
11	903-17909	Yoke, Tube, & Slip Sleeve	1
12	903-17239	55R Cross & Bearing Kit	1
13	903-18303	Friction Over Running Clutch Assembly	1
	903-18283	Guard Set	
A	903-18286	Joint & Shaft Half Assembly - 1-3/8", with Guard	
	903-18288	Joint & Shaft Half Assembly - 1-3/4", with Guard	
B	903-18287	Joint & Shaft Half Assembly - 1-3/8"	
	903-18289	Joint & Shaft Half Assembly - 1-3/4"	
C	903-18284	Joint & Tube Half Assembly, with Guard	
D	903-18285	Joint & Tube Half Assembly	
	903-18220	CV Slip Clutch PTO, 1-3/8", Complete	
	903-18221	CV Slip Clutch PTO, 1-3/4", Complete	

WEASLER 2-POINT & 3-POINT PTO SHAFT WITH TORQ MASTER CLUTCH

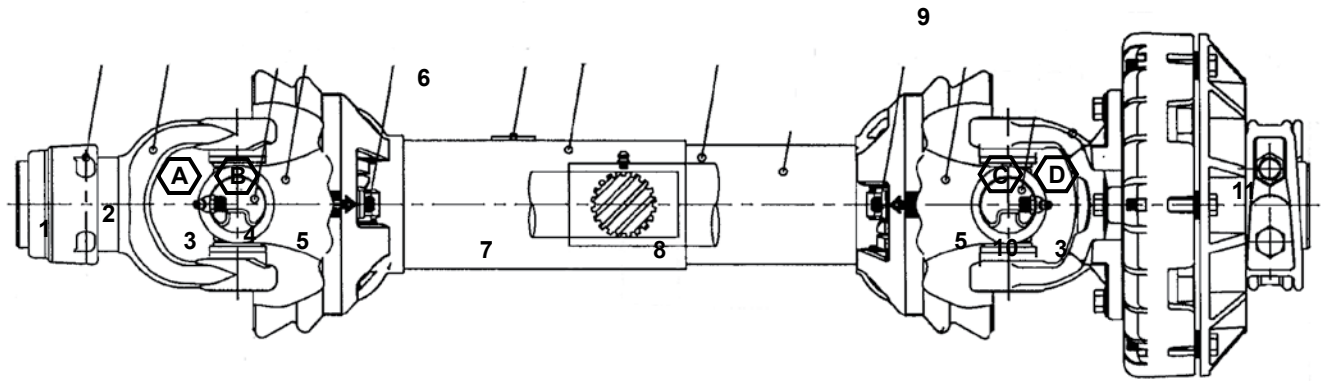

ITEM NO.	PART NUMBER	DESCRIPTION	QTY
1	903-17772	Safety Slide Lock / Auto-Lock Repair Kit	1
2	903-17418	Safety Slide Lock Yoke Assembly 1-3/4"	1
3	903-17239	55R Cross & Bearing Kit	2
4	903-17613	Yoke & Shaft 26.8 Center-End	
5	903-17774	Nylon Repair Kit (NS)	2
6	903-17455	Safety Sign	1
7	903-17614	Outer Guard, 24" Long Bell	1
		-OR-	
	903-18073	Outer Guard, 31" Long Bell	1
8	903-17725	Inner Guard	1
9	903-17456	Safety Sign	1
10	903-17724	Yoke, Tube, & Slip Sleeve	1
11	903-18303	Friction Over Running Clutch Assembly	1
	903-18290	Guard Set	
A	903-18293	Joint & Shaft Half Assembly - 1-3/8", with Guard	
	903-18295	Joint & Shaft Half Assembly - 1-3/4", with Guard	
B	903-18294	Joint & Shaft Half Assembly - 1-3/8"	
	903-18296	Joint & Shaft Half Assembly - 1-3/4"	
C	903-18291	Joint & Tube Half Assembly, with Guard	
D	903-18292	Joint & Tube Half Assembly	
	903-18218	Slip Clutch PTO, 1-3/8", Complete	
	903-18219	Slip Clutch PTO, 1-3/4", Complete	

WEASLER TORQ MASTER CLUTCH COMPONENTS

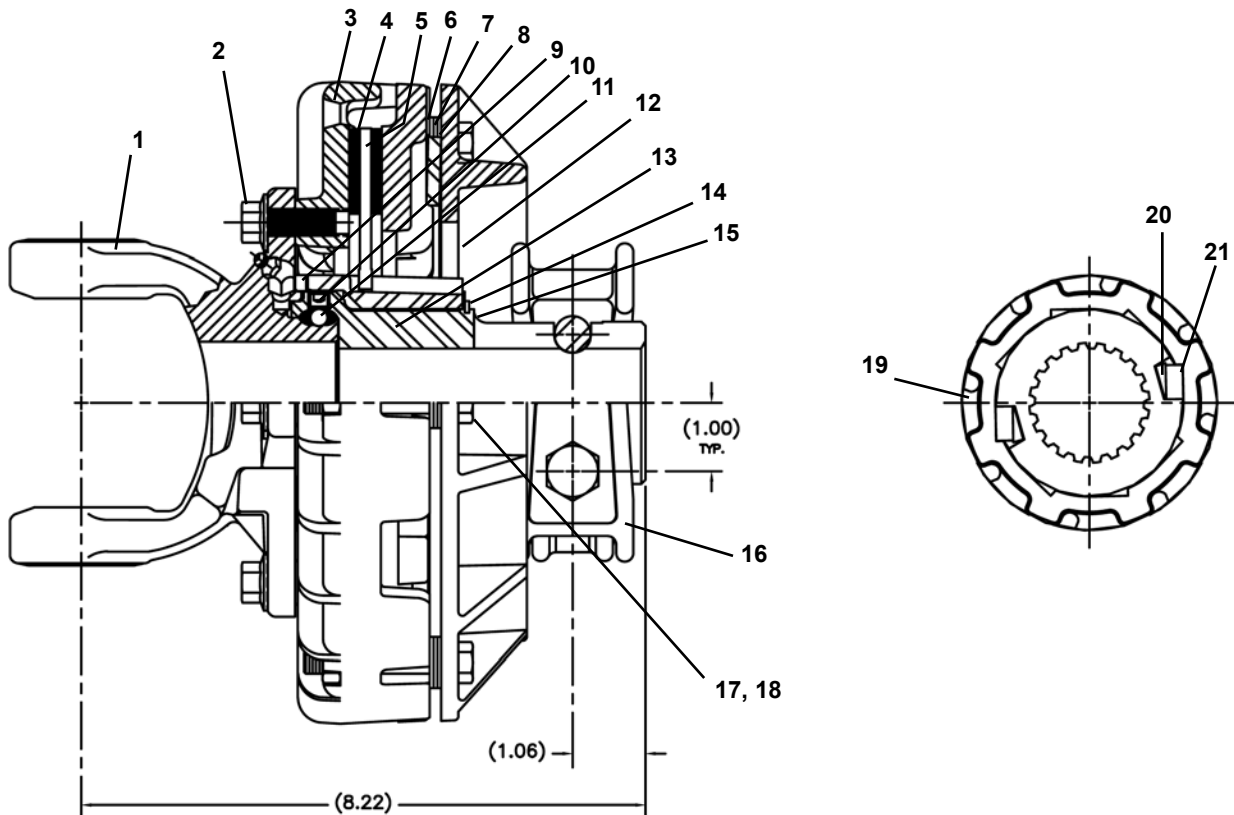

ITEM NO.	PART NUMBER	DESCRIPTION	QTY
1	903-18191	YOKE	1
	903-18226	OVERRUNNING REPAIR KIT, (2, 6, 7, 8, 9)	
2	900-03054	BOLT, M10 X 1.50 LG, CLASS 10.9	4
3	903-18227	HOUSING	1
4	903-18175	FRICTION DISC	2
5	903-18174	SEPARATOR PLATE	
6	903-18228	PRESSURE PLATE	1
7	905-14019	SPRING	1
8	900-11236	WASHER, M8 NARROW	24
9	900-03053	WAVE SPRING	1
10	903-18154	SET SCREW, .315-18 X .25 LG	1
11	903-18230	BALL, .250, GRADE 5	31
12	903-18229	COMPRESSION PLATE	1
13	903-18232	OVERRUNNING INNER HUB	1
14	903-18167	WASHER	
15	903-18168	RETAINING RING	1
16	903-18233	CLAMP	1
17	900-03053	BOLT, M8 X 1.25 X .60 LG, CLASS 10.9	6
18	900-06548	NUT, M8 X 1.25	6
19	903-18231	OVERRUNNING HUB	1
20	903-18170	LEAF SPRING	2
21	903-18171	OVERRUNNING KEY	2
	903-18234	YOKE & HUB ASM.	
	903-18235	FRICTION PACK	
	903-18303	FRICTION OVERRUNNING CLUTCH ASSEMBLY	

CENTER DRIVE GEARBOX

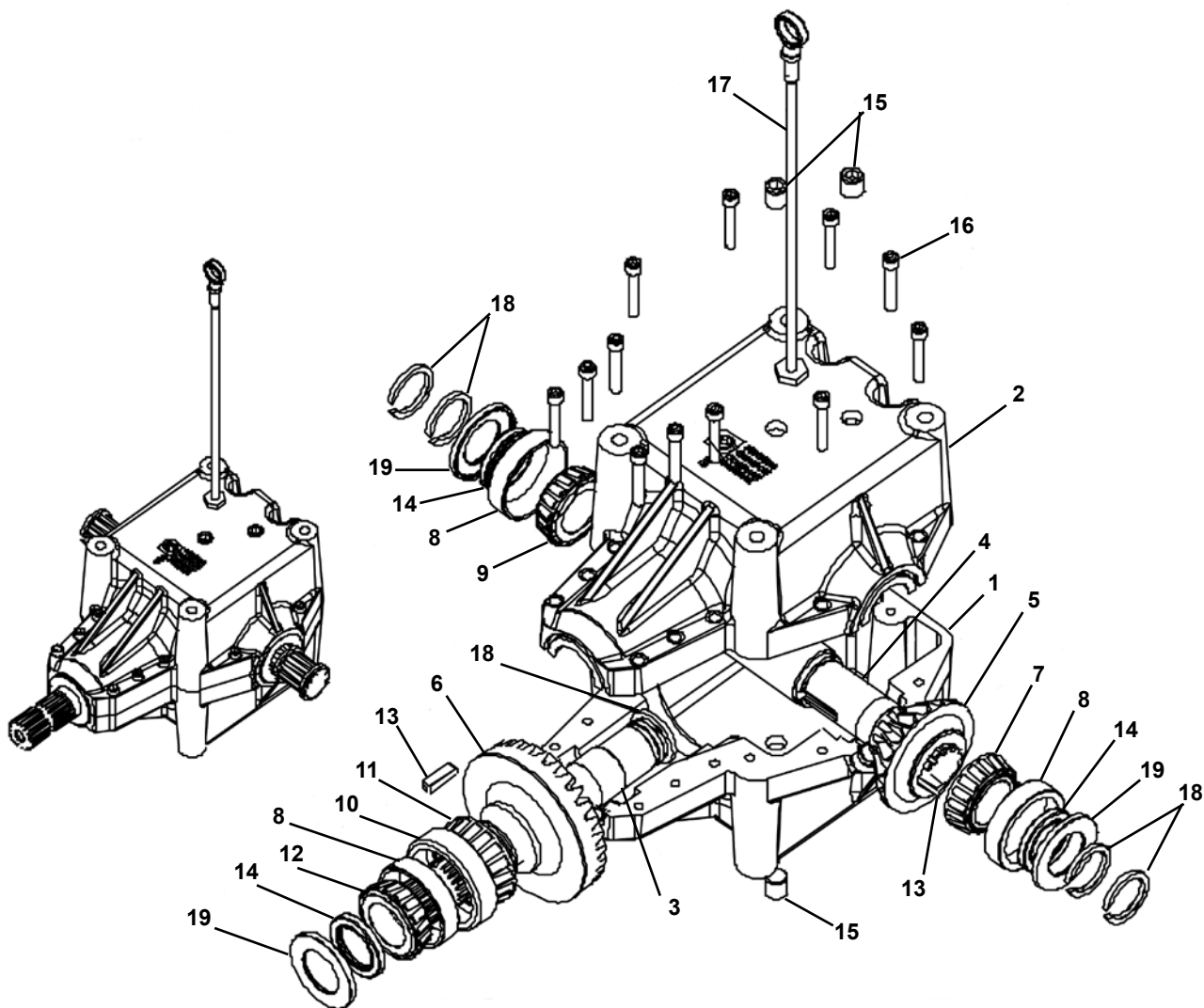

REF	PART NUMBER	DESCRIPTION	QTY
1	903-18222	HOUSING, SEAL GUARD	1
2	903-18223	CASTING, MACH R800 THRU	1
3	903-15567	SHAFT, STUB R600 KEYED 20T	1
4	903-15568	SHAFT, CROSS R600 KEYED 2X 10T	1
5	903-15321	GEAR R6 1.5 .375 KEYED 20T	1
6	903-15320	GEAR R6 1.5 .375 KEYED 30T	1
7	901-01150	BEARING, CONE 1.750 VN-25581	1
8	901-01152	BEARING, CUP 3.2650 VN-25520	3
9	901-01328	BEARING, CONE 25580	1
10	901-01153	BEARING, CUP 3.6718 VN-3720	1
11	901-09230	BEARING, CONE TMKN #3777	1
12	901-09231	BEARING, CONE TMKN #25592	1
13	903-15374	KEY, 3/8 X 3/8, 1.435	2
14	901-09125	SEAL, 1.750-2.437-.312 (R) TC	3
15	905-03078	PLUG, 1/2-14NPT SCHD W/3M	4
16	900-03033	BOLT, 3/8-16 X 2.25 SHCS	12
17	903-18225	DIPSTICK, R800 1/2-14NPT	1
18	900-39030	RETAINING RING, EXT 1.750 SHFT	5
19	901-09233	GUARD, SEAL (OD3.00 ID1.745)	3
	903-15566	COMPLETE GEARBOX	

BOLT TORQUE CHART

SAE Series Torque Chart

Always tighten hardware to these values unless a different torque value or tightening procedure is listed for a specific application. Fasteners must always be replaced with the same grade as specified in the manual parts list.

Make sure fastener threads are clean and you properly start thread engagement.

SAE Bolt Head Identification

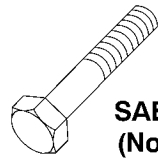

**SAE Grade 2
(No Dashes)**

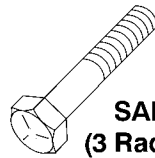

**SAE Grade 5
(3 Radial Dashes)**

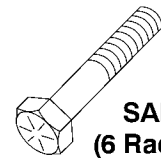

**SAE Grade 8
(6 Radial Dashes)**

Ⓐ Diameter (Inches)	Wrench Size	MARKING ON HEAD					
		SAE 2		SAE 5		SAE 8	
		Lbs.-Ft.	(N-m)	Lbs.-Ft.	(N-m)	Lbs.-Ft.	(N-m)
1/4"	7/16"	6	(8)	10	(13)	14	(18)
5/16"	1/2"	12	(17)	19	(26)	27	(37)
3/8"	9/16"	23	(31)	35	(47)	49	(67)
7/16"	5/8"	36	(48)	55	(75)	78	(106)
1/2"	3/4"	55	(75)	85	(115)	120	(163)
9/16"	13/16"	78	(106)	121	(164)	171	(232)
5/8"	15/16"	110	(149)	170	(230)	240	(325)
3/4"	1-1/8"	192	(261)	297	(403)	420	(569)
7/8"	1-5/16"	306	(416)	474	(642)	669	(907)
1"	1-1/2"	350	(475)	680	(925)	1020	(1383)
1-1/8"	1-11/16"	450	(610)	885	(1200)	<p>Bolt Diameter</p>	
1-1/4"	1-7/8"	600	(815)	1255	(1700)		
1-3/8"	2-1/16"	675	(915)	1620	(2200)		
1-1/2"	2-1/4"	920	(1250)	2200	(2900)		

Metric Series Torque Chart

Use only metric tools on metric hardware. Always tighten hardware to these values unless a different torque value or tightening procedure is listed for a specific application. Fasteners must always be replaced with the same grade.

Make sure fastener threads are clean and you properly start thread engagement.

Ⓐ Diameter & Thread Pitch (Millimeters)	Wrench Size	COARSE THREAD				FINE THREAD				Ⓐ Diameter & Thread Pitch (Millimeters)
		MARKING ON HEAD				MARKING ON HEAD				
		Metric 8.8		Metric 10.9		Metric 8.8		Metric 10.9		
		N-m	Lbs.-Ft.	N-m	Lbs.-Ft.	N-m	Lbs.-Ft.	N-m	Lbs.-Ft.	
6x1.0	10 mm	8	6	11	8	8	6	11	8	6x1.0
8x1.25	13 mm	20	15	27	20	21	16	29	22	8x1.0
10x1.5	16 mm	39	29	54	40	41	30	57	42	10x1.25
12x1.75	18 mm	68	50	94	70	75	55	103	76	12x1.25
14x2.0	21 mm	109	80	151	111	118	87	163	120	14x1.5
16x2.0	24 mm	169	125	234	173	181	133	250	184	16x1.5
18x2.5	27 mm	234	172	323	239	263	194	363	268	18x1.5
20 x 2.5	30 mm	330	244	457	337	367	270	507	374	20x1.5
22 x 2.5	34 mm	451	332	623	460	495	365	684	505	22 x 1.5
24 x 3.0	36 mm	571	421	790	583	623	459	861	635	24 x 2.0
30 x 3.0	46 mm	1175	867	1626	1199	1258	928	1740	1283	30 x 2.0

Metric Bolt Head Identification

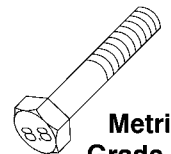

Metric Grade 8.8

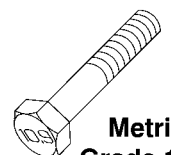

Metric Grade 10.9

Typical Washer Installations

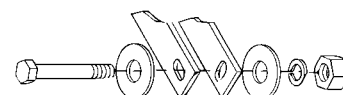
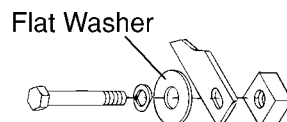
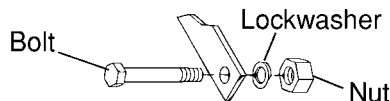

8/9/00

BOLT SIZE CHART

NOTE: Chart shows bolt thread sizes and corresponding head (wrench) sizes for standard SAE and Metric Bolts.

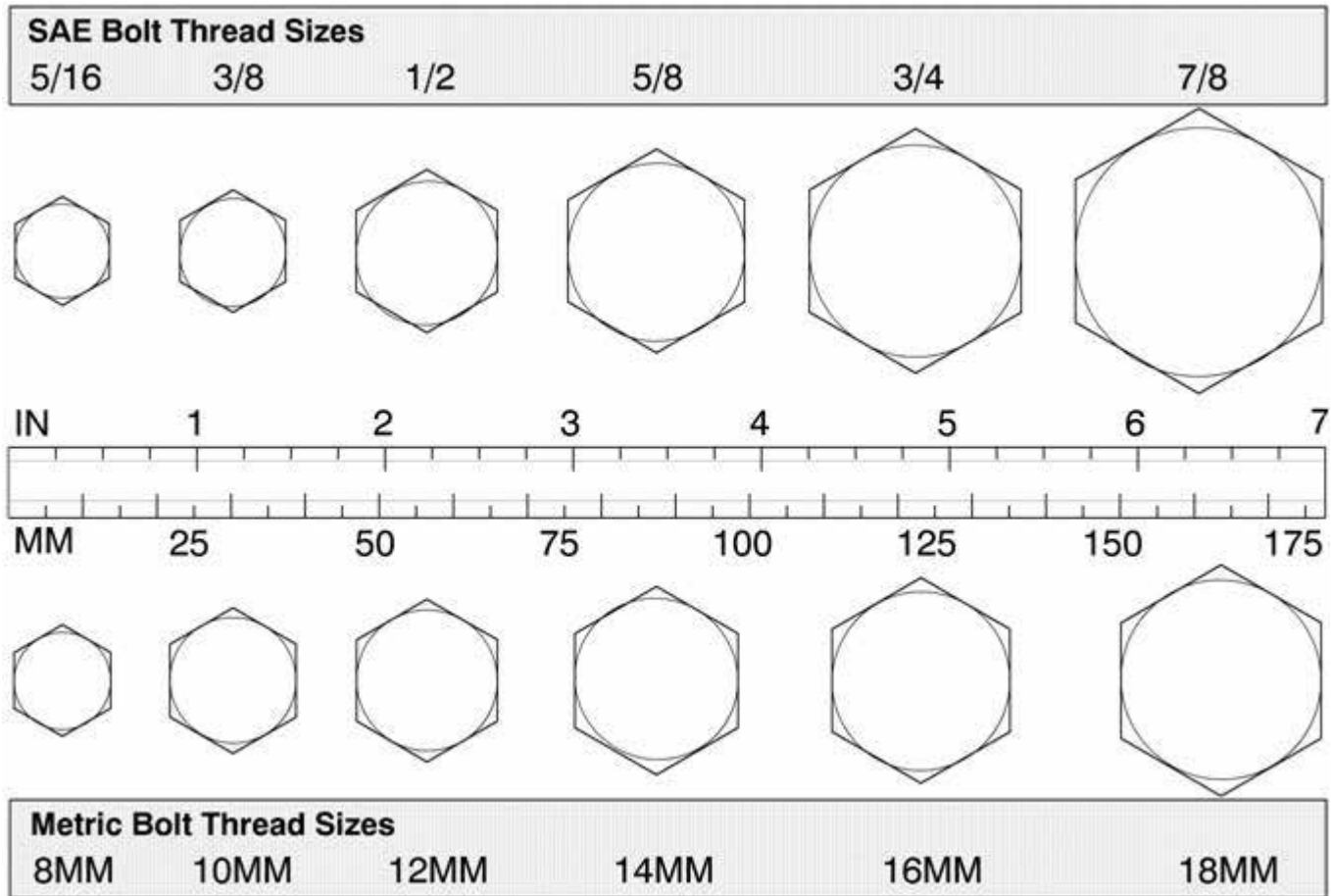

ABBREVIATIONS

AG	Agriculture	NC	National Coarse
ATF	Automatic Transmission Fluid	NF	National Fine
BSPP	British Standard Pipe Parallel	NPSM	National Pipe Straight Mechanical
BSPTM	British Standard Pipe Tapered Male	NPT	National Pipe Tapered
CV	Constant Velocity	NPT SWF	National Pipe Tapered Swivel Female
CCW	Counter-Clockwise	ORBM	O-Ring Boss - Male
CW	Clockwise	P	Pitch
F	Female	PBY	Power Beyond
GA	Gauge	psi	Pounds per Square Inch
GR (5, etc.)	Grade (5, etc.)	PTO	Power Take Off
HHCS	Hex Head Cap Screw	QD	Quick Disconnect
HT	Heat Treated	RH	Right Hand
JIC	Joint Industry Council 37° Degree Flare	ROPS	Roll Over Protective Structure
LH	Left Hand	RPM	Revolutions Per Minute
LT	Left	RT	Right
m	Meter	SAE	Society of Automotive Engineers
mm	Millimeter	UNC	Unified Coarse
M	Male	UNF	Unified Fine
MPa	Mega Pascal	UNS	Unified Special
N	Newton		

NUMERICAL INDEX

PART NO.	PAGE	PART NO.	PAGE	PART NO.	PAGE	PART NO.	PAGE
100-3-3331	51	507-1-0019	61	507-2-0125	51	900-01437	59
200-2-0553	52	507-2-0004	51	507-2-0126	51	900-01437	60
200-3-0024	52	507-2-0013	52	507-2-0130	51	900-01511	53
200-3-0024	53	507-2-0015	52	507-2-0131	51	900-01531	52
200-3-0151	52	507-2-0016	49	507-2-0132	51	900-01535	52
200-3-0959	52	507-2-0017	49	507-2-0133	51	900-01750	49
200-3-0960	52	507-2-0018	49	507-2-0134	51	900-01752	51
200-3-0961	52	507-2-0019	49	507-2-0135	51	900-01792	51
500-2-0157	55	507-2-0020	52	507-2-0136	51	900-02526	51
500-2-0157	57	507-2-0021	49	507-2-0137	51	900-03033	65
500-2-0157	60	507-2-0027	53	507-3-0012	51	900-03053	64
500-2-0158	55	507-2-0028	55	507-3-0013	51	900-03053	64
500-2-0158	60	507-2-0028	57	507-3-0023	49	900-03054	64
500-2-0161	60	507-2-0031	59	507-3-0042	49	900-03463	55
500-2-0598	51	507-2-0032	59	507-3-0046	49	900-03463	57
500-2-0684	53	507-2-0032	60	507-3-0054	49	900-03463	59
500-2-0930	61	507-2-0033	53	507-3-0109	51	900-03463	60
500-2-0998	59	507-2-0062	49	507-3-0120	49	900-06005	61
500-2-1023	59	507-2-0063	49	507-3-0121	49	900-06009	49
500-3-0136	55	507-2-0064	49	507-3-0128	49	900-06009	51
500-3-0136	57	507-2-0065	49	507-3-0157	49	900-06013	49
500-3-0136	60	507-2-0066	49	507-3-0179	55	900-06015	51
500-3-0338	49	507-2-0067	49	507-3-0179	57	900-06015	52
500-3-0338	51	507-2-0068	49	507-3-0180	55	900-06015	53
500-3-0345	51	507-2-0069	49	507-3-0180	57	900-06015	55
500-3-0785	51	507-2-0075	51	507-3-0196	49	900-06015	57
500-3-0928	55	507-2-0076	51	507-3-0209	49	900-06015	59
500-3-0928	57	507-2-0079	51	507-3-0220	49	900-06015	60
500-3-1060	51	507-2-0080	51	507-3-0221	49	900-06019	52
500-3-1151	59	507-2-0082	60	507-3-0222	49	900-06060	59
500-3-1151	60	507-2-0083	60	507-3-0223	49	900-06062	55
500-3-1328	59	507-2-0093	60	700-2-0167	59	900-06062	57
500-3-1328	60	507-2-0099	57	700-2-0168	59	900-06062	60
500-3-1696	61	507-2-0101	55	700-3-0143	59	900-06143	53
500-3-2091	61	507-2-0101	57	900-01005	61	900-06145	49
500-3-2202	59	507-2-0102	55	900-01021	55	900-06145	51
500-3-2202	60	507-2-0102	57	900-01021	57	900-06270	55
505-3-0001	51	507-2-0103	55	900-01223	49	900-06270	57
505-3-0004	51	507-2-0103	57	900-01225	53	900-06496	55
505-3-0005	51	507-2-0105	55	900-01241	59	900-06496	57
505-3-0006	51	507-2-0106	55	900-01241	60	900-06496	61
505-3-0008	51	507-2-0107	57	900-01341	49	900-06504	51
505-3-0405	51	507-2-0108	61	900-01345	49	900-06504	59
505-3-0868	49	507-2-0113	51	900-01393	49	900-06504	60
505-3-1089	49	507-2-0114	51	900-01403	52	900-06514	52
505-3-1097	49	507-2-0118	51	900-01407	51	900-06514	53
507-1-0002	52	507-2-0119	51	900-01437	55	900-06548	64
507-1-0003	53	507-2-0121	51	900-01437	57	900-11013	49

NUMERICAL INDEX *(Continued)*

PART NO.	PAGE	PART NO.	PAGE	PART NO.	PAGE	PART NO.	PAGE
900-11013	51	901-09125	65	903-18218	63	905-09067	59
900-11015	49	901-09126	49	903-18219	63	905-09068	55
900-11017	51	901-09126	51	903-18220	62	905-09068	57
900-11017	52	901-09215	59	903-18221	62	905-09068	60
900-11017	53	901-09230	65	903-18222	65	905-09135	59
900-11017	55	901-09231	65	903-18223	65	905-09136	59
900-11017	57	901-09233	65	903-18225	65	905-14019	64
900-11017	59	903-08420	51	903-18226	64	905-15024	55
900-11017	60	903-15320	65	903-18227	64	905-15024	57
900-11021	52	903-15321	65	903-18228	64	905-19224	49
900-11035	49	903-15374	65	903-18229	64	905-23014	53
900-11236	64	903-15566	49	903-18230	64	905-23014	55
900-16031	55	903-15566	65	903-18231	64	905-23014	57
900-16031	57	903-15567	65	903-18232	64	905-23014	59
900-23043	49	903-15568	65	903-18233	64	905-23014	60
900-23045	55	903-17239	62	903-18234	64		
900-23045	57	903-17239	63	903-18235	64		
900-23045	60	903-17418	63	903-18283	62		
900-23064	59	903-17455	62	903-18284	62		
900-23084	59	903-17455	63	903-18285	62		
900-25012	52	903-17456	62	903-18286	62		
900-35000	61	903-17456	63	903-18287	62		
900-39030	49	903-17613	63	903-18288	62		
900-39030	51	903-17614	63	903-18289	62		
900-39030	65	903-17724	63	903-18290	63		
900-42054	49	903-17725	63	903-18291	63		
901-01015	55	903-17733	62	903-18292	63		
901-01015	57	903-17737	62	903-18293	63		
901-01015	60	903-17739	62	903-18294	63		
901-01023	55	903-17772	62	903-18295	63		
901-01023	57	903-17772	63	903-18296	63		
901-01023	60	903-17774	62	903-18303	62		
901-01150	65	903-17774	63	903-18303	63		
901-01152	59	903-17908	62	903-18303	64		
901-01152	65	903-17909	62	904-01154	61		
901-01153	65	903-17910	62	904-01155	61		
901-01259	55	903-18057	62	905-03078	65		
901-01259	57	903-18073	63	905-07123	53		
901-01261	55	903-18106	62	905-09003	55		
901-01261	57	903-18121	62	905-09003	57		
901-01311	49	903-18154	64	905-09003	60		
901-01324	59	903-18167	64	905-09009	55		
901-01325	59	903-18168	64	905-09009	57		
901-01326	59	903-18170	64	905-09009	60		
901-01328	65	903-18171	64	905-09011	55		
901-09002	55	903-18174	64	905-09011	57		
901-09002	57	903-18175	64	905-09011	60		
901-09002	60	903-18191	64	905-09039	59		

INDEX

ASSEMBLY

- All Units, 42
- Assembling 3-Point Components, 42
- Delivery Checklist (Dealer's Responsibility), 7, 41
- Dual Safety Light (End Tow), 45
- Installing Manual Storage Tube, 43
- Installing Pull-Type Hitch, 43
- Installing wheel assembly, 42
- Pre-Delivery Checklist (Dealer's Responsibility), 7, 41
- Preparation, 42
- Safety Light Kit (Non-End Tow), 44

CHECK LISTS

- Delivery Check List(Dealer's Responsibility), 7, 41
- Pre-Delivery Check List(Dealer's Responsibility), 7, 41
- Pre-Operation Check List(Owner's Responsibility), 13

GENERAL

- Abbreviations, 67
- Bolt Size Chart, 67
- Bolt Torque Chart, 66
- Check Lists, 7, 41
- General Information, 1
- Introduction, 2
- Product Warranty, 72
- Replacement Parts Warranty, 73
- Table of Contents, 1
- Worksheet for Contour Flail Patterns, 38

OPERATION, 11

- Additional Equipment, 24
 - Center Divider, 24
 - End Guards & Skids, 24
 - Front Shield Flap, 24
- Attaching Shredder to Tractor, 16
 - 3-point and 2-point models, 16
 - Hydraulics (Center cutter option), 16
 - PTO Driveline, 16
 - Pull-type model, 16
 - Raising Stands, 17
- Breaking-in, 14
- Choosing the Correct Equipment, 13
 - 3-Point Hitch, 14
 - Drawbar clearance (Pull-type models), 14
 - Horsepower, 13
 - Load Sensing Hydraulics, 14
 - Tractor Weight, 13
- Field Operation, 17
 - Ground Speed, 23
 - Hazard Area, 23
 - Setting 3-Point & 2-Point Hitch, 20
 - Setting Operating Height, 19
 - 3-Point hitch models, 19
 - Pull-type models, 19
 - Setting Outer Trailing Wheels, 22
 - Speed vs. Weight Ratio (Table 2), 18
 - Starting the Tractor, 22
 - Stopping the Tractor, 22

OPERATION (Continued)

- Transporting the Shredder, 18
- Turning, 23
- Flail Types, 21
- Pre-Operation Check List (Owner's Responsibility), 13
- Preparing for Operation, 19
 - Flail Height, 19
- Principal Components, 12
- PTO Driveline Dimensions, 15
- Removing the Shredder from the Tractor, 17
- Setting Flail Height, 21
- Storage, 25
- Tractor Horsepower vs. Unit Width (Table 1), 13
- Transporting the Shredder, 18
- Trouble Shooting, 37

OWNER SERVICE

- Lubrication
 - Lubrication Points, 23

PARTS INDEX, 47

SAFETY

- Check Lists
 - Delivery (Dealer's Responsibility), 7, 41
 - Pre-Delivery (Dealer's Responsibility), 7, 41
 - Pre-Operation (Owner's Responsibility), 13
- Field Operation
 - Hazard Area, 23
 - Operator Sign-off Record, 10
 - Safety & Instructional Decals, 8–9
 - Safety-Alert Symbol (Explanation), 2
 - Safety Rules, 3
 - Transporting the Shredder, 18

SERVICE & MAINTENANCE

- Acceptable Oil Leakage from Gearbox, 31
- Changing Gearbox Oil, 31
- Lubricants, 26
- Lubrication Schedule, 27
- Lubrication Service Record, 30
- Replacing Flails, 33
- Replacing Rubber Shield Flaps, 33
- Replacing Stub Shaft, 35
- Servicing Modular Friction Clutch, 35
- Servicing Rotors, 34
- Setting Ratchets, 32
- Trouble Shooting, 37
- Wheel Spacing, 32

TROUBLE SHOOTING, 37

NOTES

WARRANTY

Please Enter Information Below and Save For Future Reference.

Date Purchased: _____ From (Dealer): _____

Model Number: _____ Serial Number: _____

ALLOWAY STANDARD, d/b/a ALLOWAY, warrants this product to be free from defect in material and workmanship for TWELVE (12) MONTHS COMMENCING ON THE DATE OF DELIVERY OF THE PRODUCT TO THE ORIGINAL PURCHASER.

Under no circumstances will this Warranty apply in the event that the product, in the good faith opinion of ALLOWAY, has been subjected to improper operation, improper maintenance, misuse, or an accident. This Warranty does not apply in the event that the product has been materially modified or repaired by someone other than ALLOWAY, a ALLOWAY authorized dealer or distributor, and/or a ALLOWAY authorized service center; This Warranty does not cover normal wear or tear, or normal maintenance items. This Warranty also does not cover repairs made with parts other than those obtainable through ALLOWAY.

This Warranty is extended solely to the original purchaser of the product. Should the original purchaser sell or otherwise transfer this product to a third party, this Warranty does not transfer to the third party purchaser in any way. There are no third party beneficiaries of this Warranty.

ALLOWAY makes no warranty, express or implied, with respect to tires or other parts or accessories not manufactured by ALLOWAY. Their respective manufacturers, if any, provide warranties for these items, separately. ALLOWAY'S' obligation under this Warranty is limited to, at ALLOWAYS' option, the repair or replacement, free of charge, of the product if ALLOWAY, in its sole discretion, deems it to be defective or in noncompliance with this Warranty. The product must be returned to ALLOWAY with proof of purchase within thirty (30) days after such defect or noncompliance is discovered or should have been discovered, routed through the dealer and distributor from whom the purchase was made, transportation charges prepaid. ALLOWAY shall complete such repair or replacement within a reasonable time after ALLOWAY receives the product. THERE ARE NO OTHER REMEDIES UNDER THIS WARRANTY. THE REMEDY OF REPAIR OR REPLACEMENT IS THE SOLE AND EXCLUSIVE REMEDY UNDER THIS WARRANTY.

THERE ARE NO WARRANTIES, WHICH EXTEND BEYOND THE DESCRIPTION ON THE FACE OF THIS WARRANTY. ALLOWAY MAKES NO OTHER WARRANTY, EXPRESS OR IMPLIED, AND ALLOWAY SPECIFICALLY DISCLAIMS ANY IMPLIED WARRANTY OF MERCHANTABILITY AND/OR ANY IMPLIED WARRANTY OF FITNESS FOR A PARTICULAR PURPOSE.

ALLOWAY shall not be liable for any incidental or consequential losses, damages or expenses, arising directly or indirectly from the product, whether such claim is based upon breach of contract, breach of warranty, negligence, strict liability in tort or any other legal theory. Without limiting the generality of the foregoing, Alloway specifically disclaims any damages relating to (i) lost profits, business, revenues or goodwill; (ii) loss of crops; (iii) loss because of delay in harvesting; (iv) any expense or loss incurred for labor, supplies, substitute machinery or rental; or (v) any other type of damage to property or economic loss.

This Warranty is subject to any existing conditions of supply, which may directly affect ALLOWAYS' ability to obtain materials or manufacture replacement parts.

No agent, representative, dealer, distributor, serviceperson, salesperson, or employee of any company; including without limitation, ALLOWAY, its authorized dealers, distributors, and service centers, is authorized to alter, modify, or enlarge this Warranty.

This Warranty is effective only if the warranty registration card is returned within ten (10) days.

Answers to any questions regarding warranty service and locations may be obtained by contacting:

Alloway
4230 14th Ave.NW
 Fargo, North Dakota 58102
 701-356-4983



WARRANTY

ALLOWAY STANDARD, d/b/a ALLOWAY, warrants this product to be free from defect in material and workmanship for a period of One (1) year, ninety (90) days for Service Parts, from the date of delivery of the product to the original purchaser.

Under no circumstances will this Warranty apply in the event that the product, in the good faith opinion of ALLOWAY, has been subjected to improper operation, improper maintenance, misuse, or an accident. This Warranty does not cover normal wear or tear, or normal maintenance items.

This Warranty is extended solely to the original purchaser of the product. Should the original purchaser sell or otherwise transfer this product to a third party, this Warranty does not transfer to the third party purchaser in any way. There are no third party beneficiaries of this Warranty.

ALLOWAY'S' obligation under this Warranty is limited to, at ALLOWAY'S option, the repair or replacement, free of charge, of the product if ALLOWAY, in its sole discretion, deems it, to be defective or in noncompliance with this Warranty. The product must be returned to ALLOWAY with proof of purchase within thirty (30) days after such defect or noncompliance is discovered or should have been discovered, routed through the dealer and distributor from whom the purchase was made, transportation charges prepaid. ALLOWAY shall complete such repair or replacement within a reasonable time after ALLOWAY receives the product. THERE ARE NO OTHER REMEDIES UNDER THIS WARRANTY. THE REMEDY OF REPAIR OR REPLACEMENT IS THE SOLE AND EXCLUSIVE REMEDY UNDER THIS WARRANTY.

THERE ARE NO WARRANTIES WHICH EXTEND BEYOND THE DESCRIPTION ON THE FACE OF THIS WARRANTY. ALLOWAY MAKES NO OTHER WARRANTY, EXPRESS OR IMPLIED, AND ALLOWAY SPECIFICALLY DISCLAIMS ANY IMPLIED WARRANTY OF MERCHANTABILITY AND/OR ANY IMPLIED WARRANTY OF FITNESS FOR A PARTICULAR PURPOSE.

ALLOWAY shall not be liable for any incidental or consequential losses, damages or expenses, arising directly or indirectly from the product, whether such claim is based upon breach of contract, breach, of warranty, negligence, strict liability in tort or any other legal theory. Without limiting the generality of the foregoing, Alloway specifically disclaims any damages relating to (i) lost profits, business, revenues or goodwill; (ii) loss of crops; (iii) loss because of delay in harvesting; (iv) any expense or loss incurred for labor, supplies, substitute machinery or rental; or (v) any other type of damage to property or economic loss.

This Warranty is subject to any existing conditions of supply, which may directly affect ALLOWAYS' ability to obtain materials or manufacture replacement parts.

No agent, representative, dealer, distributor, service person, salesperson, or employee of any company, including without limitation, ALLOWAY, Its authorized dealers, distributors, and service centers, IS authorized to alter, modify, or enlarge this Warranty.

Answers to any questions regarding warranty service and locations may be obtained by contacting:

Alloway
4230 14th Ave.NW
Fargo, North Dakota 58102
701-356-4983



PART NUMBER
507-3-0198

**Alloway Equipment
Company**

4230 14th Ave NW.
Fargo, ND 58102

877-275-8714 tel

701-356-4985 fax

