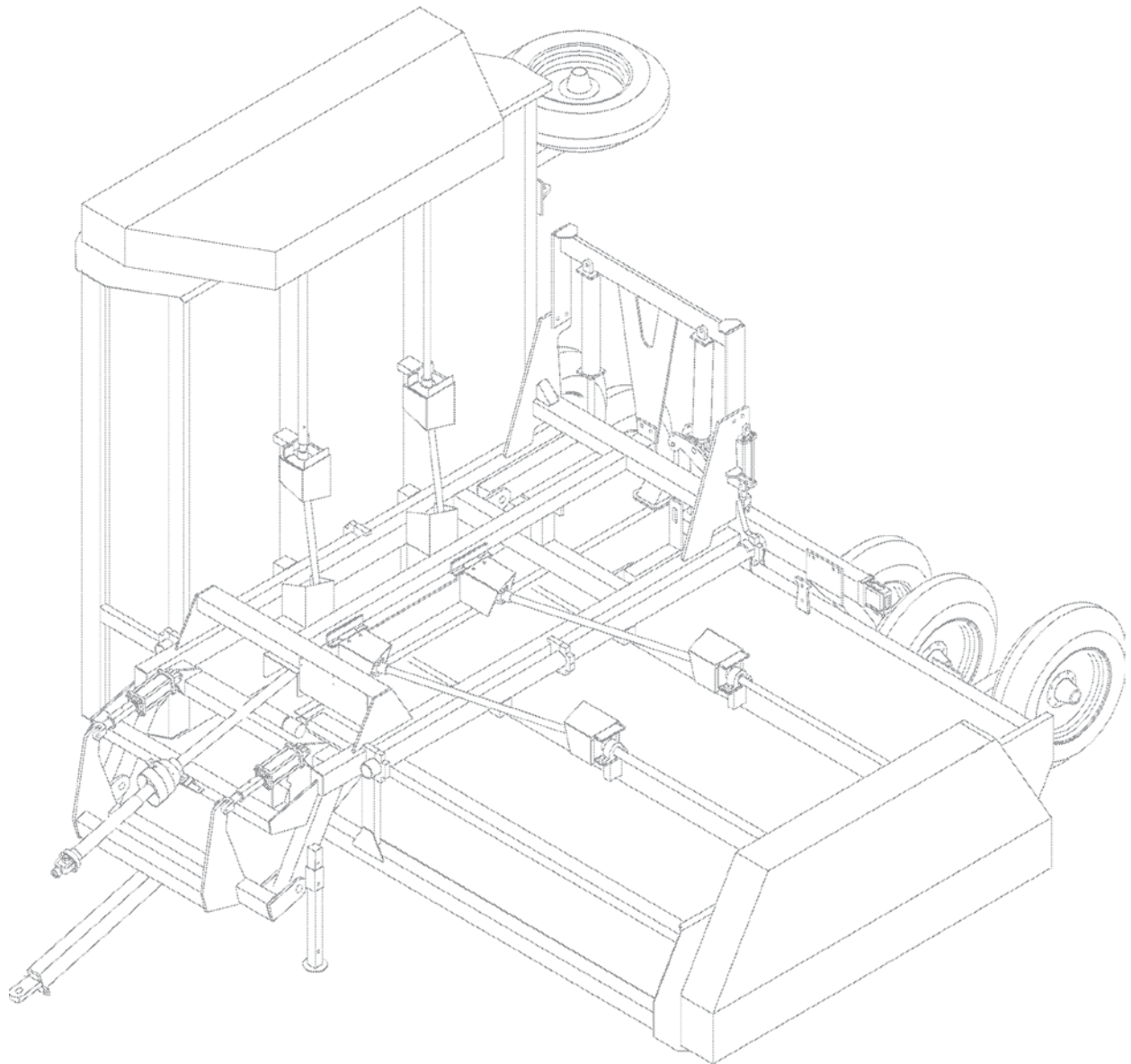




**2008**

# **FOLDING DEFOLIATOR**



# **OPERATOR'S MANUAL**

## TO THE DEALER:

Assembly and proper installation of this product is the responsibility of the Alloway dealer. Read manual instructions and safety rules. Make sure all items on the Dealer's Pre-Delivery and Delivery Check Lists in the Operator's Manual are completed before releasing equipment to the owner.

The dealer must complete the Warranty Registration included in this manual. Both dealer and customer must sign the registration which certifies that all Dealer Check List items have been completed. The dealer is to return the prepaid postage portion to Alloway, give one copy to the customer, and retain one copy. **Note: Warranty credit is subject to this form being completed and returned.**

## TO THE OWNER:

Read this manual before operating your Alloway equipment. The information presented will prepare you to do a better and safer job. Keep this manual handy for ready reference. Require all operators to read this manual carefully and become acquainted with all the adjustment and operating procedures before attempting to operate. Replacement manuals can be obtained from your dealer.

The equipment you have purchased has been carefully engineered and manufactured to provide dependable and satisfactory use. Like all mechanical products, it will require cleaning and upkeep. Lubricate the unit as specified. Observe all safety information in this manual and safety decals on the equipment.

For service, your authorized Alloway dealer has trained mechanics, genuine Alloway service parts, and the necessary tools and equipment to handle all your needs.

Use only genuine Alloway service parts. Substitute parts will void the warranty and may not meet standards required for safe and satisfactory operation. Record the model number and serial number of your equipment in the spaces provided:

**Model:** \_\_\_\_\_ **Date of Purchase** \_\_\_\_\_

**Serial Number: (see Safety Decal section for location)** \_\_\_\_\_

Provide this information to your dealer to obtain correct repair parts.

Throughout this manual, the term **IMPORTANT** is used to indicate that failure to observe can cause damage to equipment. The terms **CAUTION**, **WARNING** and **DANGER** are used in conjunction with the Safety-Alert Symbol, (a triangle with an exclamation mark), to indicate the degree of hazard for items of personal safety.



This Safety-Alert Symbol indicates a hazard and means **ATTENTION! BECOME ALERT! YOUR SAFETY IS INVOLVED!**



Indicates an imminently hazardous situation that, if not avoided, will result in death or serious injury.



Indicates a potentially hazardous situation that, if not avoided, could result in death or serious injury, and includes hazards that are exposed when guards are removed



Indicates a potentially hazardous situation that, if not avoided, may result in minor or moderate injury.

**IMPORTANT**

Indicates that failure to observe can cause damage to equipment.

**NOTE**

Indicates helpful information.



# TABLE OF CONTENTS

INTRODUCTION .....	Inside Front Cover
SPECIFICATIONS .....	1
SAFETY RULES .....	2-5
GENERAL INFORMATION .....	5
CHECK LISTS (DEALER'S RESPONSIBILITY) .....	6
SAFETY DECALS .....	7-10
OPERATOR SIGN-OFF RECORD .....	11
OPERATION .....	12-24
OWNER SERVICE .....	25-28
TROUBLE SHOOTING .....	29
INDEX TO PARTS LIST .....	31
BOLT TORQUE CHART .....	53
BOLT SIZE CHART & ABBREVIATIONS .....	54
NUMERICAL INDEX .....	56
INDEX .....	59
REPLACEMENT PARTS WARRANTY .....	60
PRODUCT WARRANTY.....	Inside Back Cover

## SPECIFICATIONS

Number of Rows .....	12
Row Spacing.....	22"
Transport Width (Folded) .....	14' 4"
Overall Width (Operating Position) .....	25' 6"
Transport Height (Folded).....	13' 4"
Tractor PTO Speed .....	1000 RPM
Tire Size .....	11.2x24
Tire Pressure .....	20 PSI
Flail Types .....	Steel (Cup-Knife) Steel (L-Knife) or Rubber
Scalper (Rotating Disc Type) .....	Optional
Weight (with Cup-Knife Rotor) .....	14,395 Lbs.
Weight (with L-Knife Rotor) .....	13,775 Lbs.
Weight (with Rubber Flail Rotor) .....	13,200 Lbs.
Weight of Optional Scalper Attachment .....	2,826 Lbs.



# SAFETY RULES

**ATTENTION! BECOME ALERT! YOUR SAFETY IS INVOLVED!**



Safety is a primary concern in the design and manufacture of our products. Unfortunately, our efforts to provide safe equipment can be wiped out by a single careless act of an operator.

In addition to the design and configuration of equipment, hazard control and accident prevention are dependent upon the awareness, concern, prudence and proper training of personnel involved in the operation, transport, maintenance and storage of equipment.

It has been said *"The best safety device is an informed, careful operator."* We ask you to be that kind of an operator.

The designed and tested safety of this equipment depends on it being operated within the limitations as explained in this manual.

## TRAINING

- **Safety instructions are important! Read all attachment and power unit manuals; follow all safety rules and safety decal information. (Replacement manuals are available from dealer). Failure to follow instructions or safety rules can result in serious injury or death.**
- **If you do not understand any part of this manual and need assistance, see your dealer.**
- **Know your controls and how to stop engine and attachment quickly in an emergency.**
- **Operators must be instructed in and be capable of the safe operation of the equipment, its attachments and all controls. Do not allow anyone to operate this equipment without proper instructions.**
- **Keep hands and body away from pressurized lines. Use paper or cardboard, not body parts to check for leaks. Wear safety goggles. Hydraulic fluid under pressure can easily penetrate skin and will cause serious injury or death.**
- **Make sure that all operating and service personnel know that in the event hydraulic fluid penetrates skin, it must be surgically removed as soon as possible by a doctor familiar with this form of injury, or gangrene, serious injury or death will result. CONTACT A PHYSICIAN IMMEDIATELY IF FLUID ENTERS SKIN OR EYES. DO NOT DELAY.**
- **Never allow children or untrained persons to operate equipment.**

## PREPARATION

- **Check that all hardware is tight and properly installed. Always tighten to torque chart specifications unless instructed otherwise in this manual.**
- **Air in hydraulic systems can cause erratic operation and allows loads or equipment components to drop unexpectedly. Before operating or allowing anyone to approach the equipment, purge any air in the system by operating all hydraulic functions several times after connecting equipment, connecting hoses, or doing any hydraulic maintenance.**
- **Make sure all hydraulic hoses, fittings and valves are in good condition and not leaking before starting power unit or using equipment. Check and route hoses carefully to prevent damage. Hoses must not be twisted, bent sharply, kinked, frayed, pinched, or come into contact with any moving parts. Operate moveable components through full operational range to check clearances. Replace any damaged hoses immediately.**
- **Always wear relatively tight and belted clothing to avoid entanglement in moving parts. Wear sturdy, rough-soled work shoes and protective equipment for eyes, hair, hands, hearing and head; and respirator or filter mask where appropriate.**
- **Ensure implement is properly attached, adjusted and in good operating condition.**
- **Make sure spring-activated locking pin or collar slides freely and is seated firmly in tractor PTO spline groove.**
- **Before starting power unit, check all equipment driveline guards for damage and make sure they rotate freely on all drivelines. Replace any damaged guards. If guards do not rotate freely on drivelines, repair and replace bearings before operating.**
- **Power unit must be equipped with ROPS or ROPS CAB and seat belt. Keep seat belt securely fastened. Falling off power unit can result in death from being run over or crushed. Keep foldable ROPS systems in "locked up" position at all times.**
- **Connect PTO driveline directly to power unit PTO shaft. Never use adapter sleeves or adapter shafts. Adapters can cause driveline failures due to incorrect spline or incorrect operating length and can result in personal injury or death.**

# SAFETY RULES



**ATTENTION! BECOME ALERT! YOUR SAFETY IS INVOLVED!**



- Inspect rubber flaps and swing rod before each use. Replace if damaged or missing. Flaps must pivot and hang freely so there are no gaps. Do not put equipment into service until repaired.
- Remove accumulated debris from this equipment, tractor and engine to avoid fire hazard.
- Ensure all safety decals are installed. Replace if damaged. (See Safety Decals section for location.)
- Ensure shields and guards are properly installed and in good condition. Replace if damaged.
- A minimum 20% of tractor and equipment weight must be on tractor front wheels when attachments are in transport position. Without this weight, tractor could tip over, causing personal injury or death. The weight may be attained with a loader, front wheel weights, ballast in tires or front tractor weights. When attaining the minimum 20% weight on the front wheels, you must not exceed the Roll Over Protection Structure (ROPS) weight certification. Weigh the tractor and equipment. Do not estimate.
- Make sure hydraulic hoses and cylinders are fully purged of air before operating. Keep all persons away and fill the system by raising and lowering all functions several times. Air in the system can allow components to fall unexpectedly.
- Inspect and clear area of stones, branches, or other hard objects that might be thrown, causing injury or damage.

---

## TRANSPORTING

- Power unit must be equipped with ROPS or ROPS cab and seat belt. Keep seat belt securely fastened. Falling off power unit can result in death from being run over or crushed. Keep foldable ROPS systems in "locked up" position at all times.
- Always sit in power unit seat when operating controls or starting engine. Securely fasten seat belt, place transmission in neutral, engage brake, and ensure all other controls are disengaged before starting power unit engine.
- A minimum 20% of tractor and equipment weight must be on the tractor front wheels when attachments are in transport position. Without this weight, tractor could tip over, causing personal injury or death.

The weight may be attained with a loader, front wheel weights, ballast in tires or front tractor weights. Weigh the tractor and equipment. Do not estimate.

- Always attach safety chain to tractor drawbar when transporting unit.
- Always raise unit and install transport locks before transporting. Leak down or failure of mechanical or hydraulic system can cause equipment to drop.
- Never exceed 20 MPH during transport. See the Speed vs. Weight Ratio Table in "Field Operation, Transporting the Unit" for proper tow vehicle to machine weight ratios.
- Watch for hidden hazards on the terrain.
- Always comply with all state and local lighting and marking requirements.
- Never allow riders on power unit or attachment.
- Do not operate PTO during transport.
- Look down and to the rear and make sure area is clear before operating in reverse.
- Do not operate or transport on steep slopes.
- Use extreme care and reduce ground speed on slopes and rough terrain.
- Do not operate or transport equipment while under the influence of alcohol or drugs.

## OPERATION

- Equipment may be pictured with covers open for instructional purposes. Never operate equipment with covers open.
- Do not allow bystanders in the area when operating, attaching, removing, assembling, or servicing equipment.
- Do not allow anyone to stand between tractor and unit when backing up to unit.
- Never go underneath equipment (lowered to the ground or raised) unless it is properly blocked and secured. Never place any part of the body underneath equipment or between moveable parts even when the engine has been turned off. Hydraulic system leak down, hydraulic system failures, mechanical failures, or movement of control levers can cause equipment to drop or rotate unexpectedly and cause severe injury or death. Follow Operator's Manual instructions for working underneath and blocking requirements or have work done by a qualified dealer.

*(Safety Rules continued on next page)*



# SAFETY RULES

**ATTENTION! BECOME ALERT! YOUR SAFETY IS INVOLVED!**



*(Safety Rules continued from previous page)*

- Keep bystanders away from equipment.
- Do not operate or transport equipment while under the influence of alcohol or drugs.
- Operate only in daylight or good artificial light.
- Avoid contact with electrical wires.
- Keep hands, feet, hair, and clothing away from equipment while engine is running. Stay clear of all moving parts.
- Always comply with all state and local lighting and marking requirements.
- Never allow riders on power unit or attachment.
- Power unit must be equipped with ROPS or ROPS cab and seat belt. Keep seat belt securely fastened. Falling off power unit can result in death from being run over or crushed. Keep foldable ROPS systems in "locked up" position at all times.
- Always sit in power unit seat when operating controls or starting engine. Securely fasten seat belt, place transmission in neutral, engage brake, and ensure all other controls are disengaged before starting power unit engine.
- Operate tractor PTO at the RPM speed stated in "Specifications" section.
- Do not operate PTO during transport.
- Look down and to the rear and make sure area is clear before operating in reverse.
- Do not operate or transport on steep slopes.
- Do not stop, start, or change directions suddenly on slopes.
- Use extreme care and reduce ground speed on slopes and rough terrain.
- Watch for hidden hazards on the terrain during operation.
- Stop power unit and equipment immediately upon striking an obstruction. Turn off engine, remove key, inspect, and repair any damage before resuming operation.
- Never work on scalper attachment in the raised position. Lower scalpings to the ground and service each unit individually.
- Always raise scalper arms before going in reverse.

- Always connect safety chain from equipment to towing vehicle when transporting.
- **AVOID INJURY OR DEATH FROM POWER LINES:**
  - Stay away from power lines.
  - Electrocutation can occur without direct contact.
  - Check clearances before raising implement.
  - Do not leave the operator's seat if any part of the tractor or implement contacts electric lines.
- Before servicing, adjusting, repairing or unplugging, stop tractor engine, place all controls in neutral, set park brake, remove ignition key, and wait for all moving parts to stop.
- Before working underneath a raised implement, read and follow all Operator's Manual instructions and safety rules. Implement must be attached to tractor. Lift cylinder locks must be installed and lift cylinders lowered against locks. Hydraulic system leak down, hydraulic system failures, or movement of control levers can cause equipment to drop unexpectedly and cause severe injury or death.

---

## MAINTENANCE

- Before servicing, adjusting, repairing or unplugging, stop tractor engine, place all controls in neutral, set park brake, remove ignition key, and wait for all moving parts to stop.
- Before working underneath a raised implement, read and follow all Operator's Manual instructions and safety rules. Implement must be attached to tractor. Lift cylinder locks must be installed and lift cylinders lowered against locks. Hydraulic system leak down, hydraulic system failures, or movement of control levers can cause equipment to drop unexpectedly and cause severe injury or death.
- Service and maintenance work not covered in OWNER SERVICE must be done by a qualified dealership. Special skills, tools, and safety procedures may be required. Failure to follow these instructions can result in serious injury or death.
- Do not modify or alter or permit anyone else to modify or alter the equipment or any of its components in any way.
- Your dealer can supply original equipment hydraulic accessories and repair parts. Substitute parts may not meet original equipment specifications and may be dangerous.

# SAFETY RULES



**ATTENTION! BECOME ALERT! YOUR SAFETY IS INVOLVED!**



- Always wear relatively tight and belted clothing to avoid entanglement in moving parts. Wear sturdy, rough-soled work shoes and protective equipment for eyes, hair, hands, hearing and head; and respirator or filter mask where appropriate.
- Do not allow other people in the area when operating, attaching, removing, assembling or servicing equipment.
- Never go underneath equipment lowered to the ground or raised, unless it is properly blocked and secured. Never place any part of the body underneath equipment or between moveable parts even when the engine has been turned off. Hydraulic system leak down, hydraulic system failures, mechanical failures or movement of control levers can cause equipment to drop or rotate unexpectedly and cause severe injury or death. Follow Operator's Manual instructions for working underneath and blocking requirements, or have work done by a qualified dealer.
- Ensure implement is properly attached, adjusted and in good operating condition.
- Never perform service or maintenance with engine running.
- Make sure hydraulic hoses and cylinders are fully purged of air before operating. Keep all persons away and fill the system by raising and lowering all functions several times. Air in the system can allow components to fall unexpectedly.

- Keep all persons away from operator control area while performing adjustments, service or maintenance.
- Make certain all movement of implement components has stopped before approaching for service.
- Do not handle blades with bare hands. Careless or improper handling may result in serious injury.
- Tighten all bolts, nuts and screws to torque chart specifications. Check that all cotter pins are installed securely to ensure equipment is in a safe condition before operating.
- Ensure all safety decals are installed. Replace if damaged. (See Safety Decals section for location.)
- Ensure shields and guards are properly installed and in good condition. Replace if damaged.
- Do not disconnect hydraulic lines until machine is securely blocked or placed in lowest position and system pressure is released by operating all valve control levers.

---

## STORAGE

- Follow manual instructions for storage.
- Keep children and bystanders away from storage area.

---

## GENERAL INFORMATION

The purpose of this manual is to assist you in operating and maintaining your Folding Defoliator. Read it carefully. It furnishes information and instructions that will help you achieve years of dependable performance. These instructions have been compiled from extensive field experience and engineering data. Some information may be general in nature due to unknown and varying operating conditions. However, through experience and these instructions, you should be able to develop procedures suitable to your particular situation.

The illustrations and data used in this manual were current at the time of printing, but due to possible inline production changes, your machine may vary

Slightly in detail. We reserve the right to redesign and change the machines as may be necessary without notification.



### WARNING

- Some illustrations in this manual show the Folding Defoliator with safety shields removed to provide a better view. The Folding Defoliator should never be operated with any safety shielding removed.

Throughout this manual, references are made to right and left direction. These are determined by standing behind the equipment facing the direction of forward travel.

# CHECK LISTS

## PRE-DELIVERY CHECK LIST

(DEALER'S RESPONSIBILITY)

Inspect the equipment thoroughly after assembly to ensure it is set up properly before delivering it to the customer.

The following check lists are a reminder of points to inspect. Check off each item as it is found satisfactory or after proper adjustment is made.

- \_\_\_ Check that all safety decals are installed and in good condition. Replace if damaged.
- \_\_\_ Check that shields and guards are properly installed and in good condition. Replace if damaged.
- \_\_\_ Check that PTO shaft is properly installed.
- \_\_\_ Properly attach implement to tractor and make all necessary adjustments.
- \_\_\_ Check all bolts to be sure they are tight.
- \_\_\_ Check wheel bolts for proper torque.
- \_\_\_ Check that all cotter pins and safety pins are properly installed. Replace if damaged.
- \_\_\_ Check and grease all lubrication points as identified in "Service, lubrication information."
- \_\_\_ Check the level of gearbox fluids before delivery. Service, if required, as specified in the "Service, lubrication information."
- \_\_\_ Check that tractor hydraulic reservoir has been serviced and that hydraulic system and all functions have been operated through full cylinder stroke to purge air from system.
- \_\_\_ After pressurizing and operating all Defoliator functions, stop tractor and make sure there are no leaks in the hydraulic system. Follow all safety rules when checking for leaks.

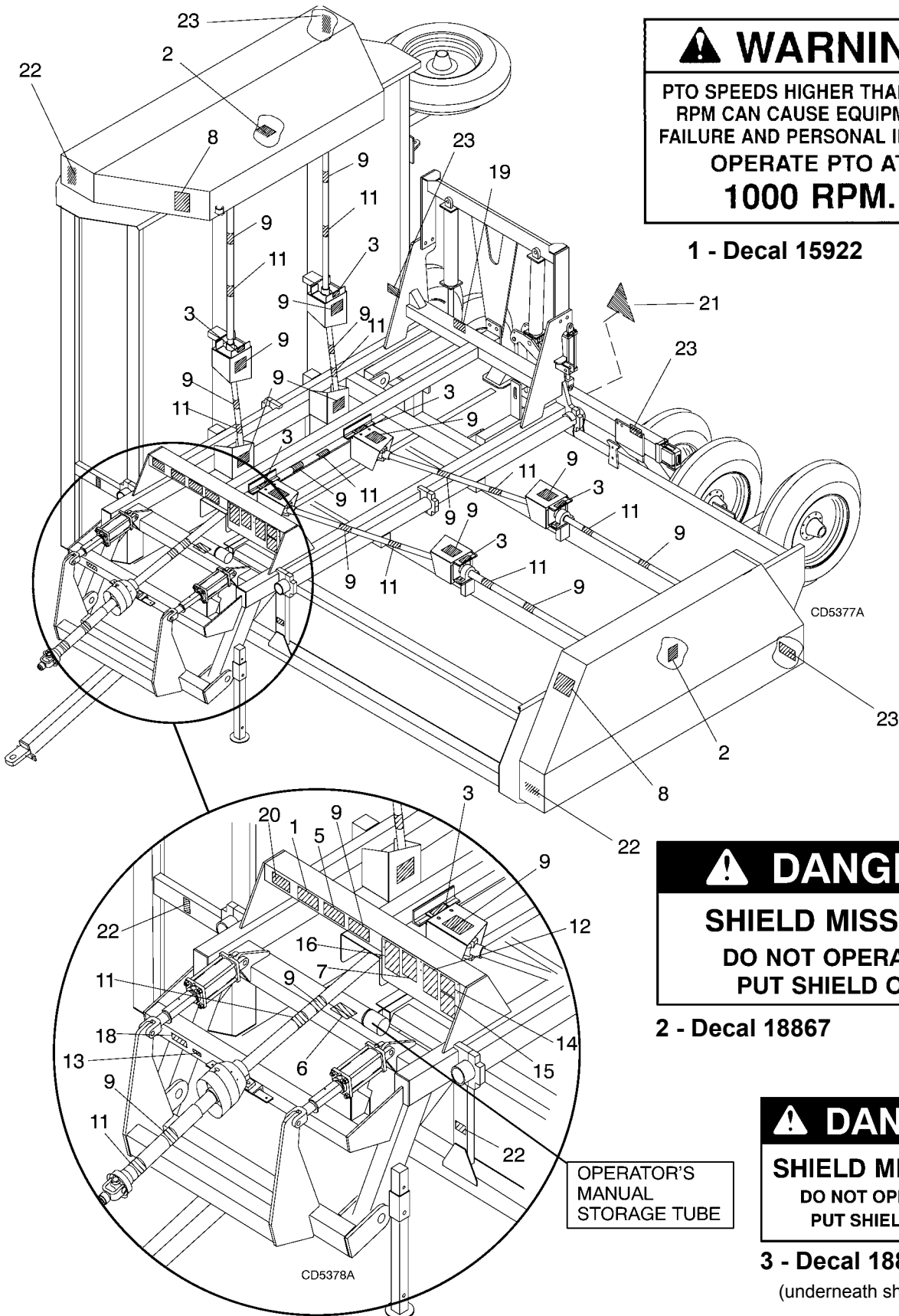
## DELIVERY CHECK LIST

(DEALER'S RESPONSIBILITY)

- \_\_\_ Show customer how to make adjustments and select proper PTO speed.
- \_\_\_ Show customer how to make adjustments.
- \_\_\_ Instruct customer how to lubricate and explain importance of lubrication.
- \_\_\_ Point out the safety decals. Explain their meaning and the need to keep them in place and in good condition. Emphasize the increased safety hazards when instructions are not followed.
- \_\_\_ Present Operator's Manual and request that customer and all operators read it before operating equipment. Point out the manual safety rules, explain their meanings and emphasize the increased safety hazards that exist when safety rules are not followed.
- \_\_\_ Show customer how to make sure driveline is properly installed and that spring-activated locking pin or collar slides freely and is seated in groove on tractor PTO shaft.
- \_\_\_ Show customer the safe, proper procedures to be used when mounting, dismounting, and storing equipment.
- \_\_\_ Explain to customer that when equipment is transported on a road or highway, safety devices should be used to give adequate warning to operators of other vehicles.
- \_\_\_ Explain to customer that when equipment is transported on a road or highway, a Slow Moving Vehicle (SMV) sign should be used to provide adequate warning to operators of other vehicles.
- \_\_\_ Explain to customer that when towing on a public road to comply with all state and local lighting/marketing laws and to use a safety tow chain.
- \_\_\_ Make customer aware of optional equipment available so that customer can make proper choices as required.
- \_\_\_ Point out all guards and shields. Explain their importance and the safety hazards that exist when not kept in place and in good condition.



**SAFETY & INSTRUCTIONAL DECALS**  
**ATTENTION! BECOME ALERT! YOUR SAFETY IS INVOLVED!**  
 Replace Immediately If Damaged!



**⚠ WARNING**  
 PTO SPEEDS HIGHER THAN 1000  
 RPM CAN CAUSE EQUIPMENT  
 FAILURE AND PERSONAL INJURY.  
 OPERATE PTO AT  
**1000 RPM.** 15922

**1 - Decal 15922**

**⚠ DANGER**  
**SHIELD MISSING**  
 DO NOT OPERATE  
 PUT SHIELD ON 18867


**2 - Decal 18867**

**⚠ DANGER**  
**SHIELD MISSING**  
 DO NOT OPERATE  
 PUT SHIELD ON 18868

**3 - Decal 18868**  
 (underneath shield)

OPERATOR'S  
 MANUAL  
 STORAGE TUBE

**SAFETY & INSTRUCTIONAL DECALS**  
**ATTENTION! BECOME ALERT! YOUR SAFETY IS INVOLVED!**  
**Replace Immediately If Damaged!**

 <small>19924</small>	<p><b>⚠ WARNING</b></p> <p><b>HIGH PRESSURE HYDRAULIC OIL LEAKS CAN PENETRATE SKIN</b></p> <ul style="list-style-type: none"> <li>■ CHECK FOR LEAKS WITH CARDBOARD; NEVER USE HAND.</li> <li>■ BEFORE LOOSENING FITTINGS: LOWER LOAD, RELEASE PRESSURE, AND BE SURE OIL IS COOL.</li> <li>■ CONSULT PHYSICIAN IMMEDIATELY IF SKIN PENETRATION OCCURS.</li> </ul> <p><b>SKIN PENETRATION CAN RESULT IN SERIOUS INJURY AND GANGRENE.</b></p>
---	--

5 - Decal 19924

<p><b>⚠ WARNING</b></p> <p><b>MANUAL CONTAINER AND MANUAL ARE MISSING</b></p> <ul style="list-style-type: none"> <li>■ REPLACE AND READ BEFORE OPERATING.</li> <li>■ KEEP MANUAL CONTAINER AND MANUAL MOUNTED IN THIS LOCATION. (Available from dealer or call 1-877-275-8714.)</li> </ul> <p><b>FAILURE TO FOLLOW MANUAL INSTRUCTIONS AND SAFETY RULES CAN RESULT IN SERIOUS INJURY OR DEATH.</b> <small>506-3-0192</small></p>
--

6 - Decal 50630192

9 - Decal 18864

<p><b>⚠ DANGER</b></p>

<p><b>ROTATING DRIVELINE CONTACT CAN CAUSE DEATH</b></p> <p><b>KEEP AWAY!</b></p> <p><b>DO NOT OPERATE WITHOUT-</b></p> <ul style="list-style-type: none"> <li>• ALL DRIVELINE GUARDS, TRACTOR AND EQUIPMENT SHIELDS IN PLACE</li> <li>• DRIVELINES SECURELY ATTACHED AT BOTH ENDS</li> <li>• DRIVELINE GUARDS THAT TURN FREELY ON DRIVELINE</li> </ul> <p style="text-align: right;"><small>18864B</small></p>

13 - Serial Number Plate

MODEL NO.	SERIAL NO.	YR OF MFG.
ID NO.	MASS (KG)	

<p><b>⚠ DANGER</b></p>

<p><b>GUARD MISSING. DO NOT OPERATE.</b></p>
<p><b>⚠ DANGER</b></p>


<p><b>GUARD MISSING. DO NOT OPERATE.</b></p> <p style="text-align: right;"><small>33347E</small></p>
<p><b>⚠ DANGER</b></p>

11 - Decal 33347  
(underneath driveline guard)

7 - Decal 70030493

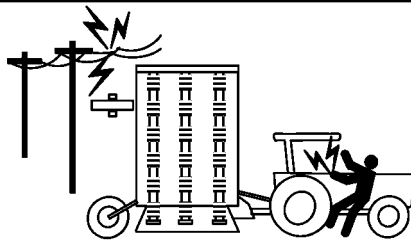
<p><b>⚠ WARNING</b></p> <p><b>TO AVOID SERIOUS INJURY OR DEATH:</b></p> <ul style="list-style-type: none"> <li>■ Read Operator's Manual before operating, servicing or repairing equipment. Follow all safety rules and instructions. Store Manual in Manual Container on this equipment. (Manuals are available from dealer or, in the United States and Canada, call 1-877-275-8714.)</li> <li>■ Keep all guards in place, properly secured and in good condition. Replace if damaged.</li> <li>■ Operate from tractor seat only.</li> <li>■ Do not allow any other persons in the area when operating.</li> <li>■ Allow no children or untrained persons to operate the equipment.</li> <li>■ Before dismounting tractor: <ul style="list-style-type: none"> <li>■ Disengage PTO.</li> <li>■ Lower equipment and all raised components,</li> <li>■ Stop engine, remove key and engage brake.</li> <li>■ Operate hydraulic valve levers to release any pressure.</li> </ul> </li> </ul> <p><b>FAILURE TO FOLLOW THESE INSTRUCTIONS CAN RESULT IN SERIOUS INJURY OR DEATH.</b> <small>PN-70030493-A</small></p>
--

**SAFETY & INSTRUCTIONAL DECALS**  
**ATTENTION! BECOME ALERT! YOUR SAFETY IS INVOLVED!**  
 Replace Immediately If Damaged!

<b>⚠ WARNING</b>	
	<p style="text-align: center;"><b>ROTATING DRIVE HAZARDS</b></p> <ul style="list-style-type: none"> <li>■ Before opening drive guard:           <ul style="list-style-type: none"> <li>■ Disengage PTO drive,</li> <li>■ Lower equipment to ground,</li> <li>■ Stop engine, remove key and engage brake,</li> <li>■ Operate valve levers to release any hydraulic pressure,</li> <li>■ Wait for all rotation to stop,</li> <li>■ Disconnect driveline from tractor PTO.</li> </ul> </li> <li>■ Before starting tractor:           <ul style="list-style-type: none"> <li>■ Close drive cover and secure,</li> <li>■ Keep guard in good condition.</li> </ul> </li> </ul> <p style="text-align: center;"><b>FAILURE TO FOLLOW THESE INSTRUCTIONS CAN RESULT IN SERIOUS INJURY OR DEATH.</b></p>

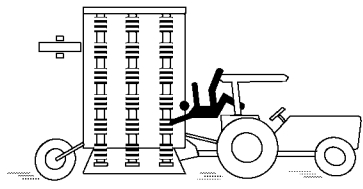
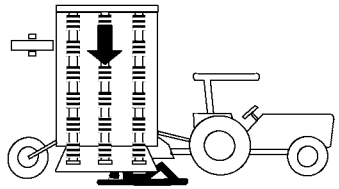
8 - Decal 70030495

14 - Decal 50031687

<b>⚠ DANGER</b>	
	
<b>ELECTROCUTION HAZARD</b>	
<ul style="list-style-type: none"> <li>● Keep away from electric lines.</li> <li>● Electrocution can result without direct contact.</li> </ul> <p style="text-align: center;"><b>Power lines can cause serious injury or death.</b></p>	

20 - Decal 50031689

<b>⚠ CAUTION</b>	
<b>AVOID ROTOR DAMAGE FROM RAISING OR LOWERING WINGS.</b>	
<p>Before raising or lowering wings:</p> <ul style="list-style-type: none"> <li>● Follow all manual instructions and safety rules.</li> <li>● Raise equipment to maximum height to provide necessary ground clearance below rotor.</li> <li>● Install cylinder locks on all four lift cylinders.</li> </ul>	
<b>FAILURE TO FOLLOW INSTRUCTIONS CAN RESULT IN ROTOR DAMAGE AND PERSONAL INJURY.</b>	

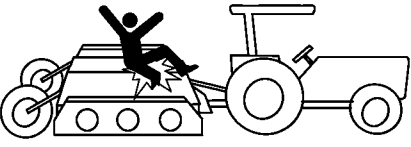
<b>⚠ WARNING</b>	
	
<b>FALLING OFF CAN RESULT IN BEING RUN OVER.</b>	
<ul style="list-style-type: none"> <li>■ Buckle Up! Tractor should have ROPS and seat belt.</li> <li>■ Allow no riders on tractor or equipment.</li> </ul>	
<b>RAISED EQUIPMENT OR COMPONENTS CAN DROP AND CRUSH.</b>	
<ul style="list-style-type: none"> <li>■ Before servicing, working on or working underneath equipment, read manual instructions.</li> <li>■ Manual instructions and all safety rules for securing equipment and components must be followed to prevent crushing from hydraulic leak down, hydraulic system failure, movement of control levers or mechanical component failures.</li> </ul>	
<b>FALLING OFF OR GOING UNDER RAISED EQUIPMENT CAN RESULT IN SERIOUS INJURY OR DEATH.</b>	

12 - Decal 50031688

21 - SMV (Slow Moving Vehicle)  
 Sign PN-50031696

**SAFETY & INSTRUCTIONAL DECALS**  
**ATTENTION! BECOME ALERT! YOUR SAFETY IS INVOLVED!**  
 Replace Immediately If Damaged!

**⚠ WARNING**



**STANDING ON DEFOLIATOR CAN RESULT IN FALLING INTO FLAIL ROTORS.**

- Do not stand or walk on defoliator housing.
- Defoliator covering will not support people or animals.

**FALLING INTO FLAIL ROTORS CAN RESULT IN SERIOUS INJURY OR DEATH.**

PN-50031690

15 - Decal 50031690

**⚠ WARNING**



**RAISED WING EXPOSES FLAIL ROTORS AND INCREASES THROWN OBJECT HAZARDS.**

- Only raise wings for transport.
- Read and follow all manual instructions. Stop equipment and pin wings in "Lock-Up" position before transporting.
- Wings must be completely lowered to the ground when operating.

**RAISED WING CAN FALL AND CRUSH.**

- Keep away. Never go under a raised wing.
- Raised wing must always be pinned in "Lock-Up" position.
- Lower wings after transport.
- Wings must be lowered before any service work and for storage.

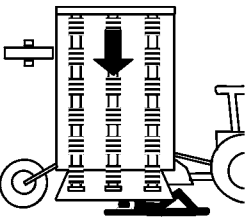
**FAILURE TO FOLLOW INSTRUCTIONS CAN RESULT IN SERIOUS INJURY OR DEATH.**

50031691

16 - Decal 50031691

18 - Decal 50031693

**⚠ WARNING**



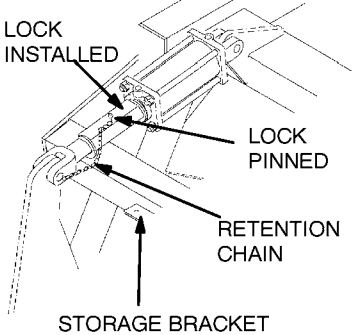
50021693

**RAISED EQUIPMENT CAN DROP AND CRUSH**

**Before working on or underneath equipment:**

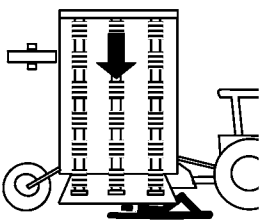
- Read and follow all manual instructions and safety rules.
- Install cylinder locks on both front lift cylinders.
- Cylinder locks must be installed correctly, kept in good condition, and stored on equipment when not in use.
- All four corners of both wings must be securely blocked with jack stands.

**FAILURE TO FOLLOW INSTRUCTIONS CAN RESULT IN SERIOUS INJURY OR DEATH.**



19 - Decal 50031694

**⚠ WARNING**



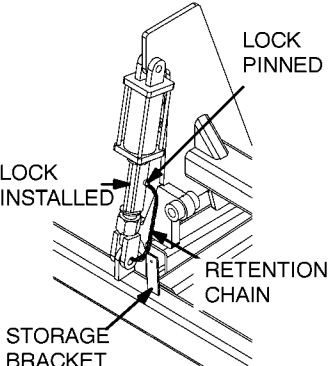
PN-50031694

**RAISED EQUIPMENT CAN DROP AND CRUSH**

**Before working on or underneath equipment:**

- Read and follow all manual instructions and safety rules.
- Install cylinder locks on both rear lift cylinders.
- Cylinder locks must be installed correctly, kept in good condition, and stored on equipment when not in use.
- All four corners of both wings must be securely blocked with jack stands.

**FAILURE TO FOLLOW INSTRUCTIONS CAN RESULT IN SERIOUS INJURY OR DEATH.**





# OPERATION

Safety is a primary concern in the design and manufacture of our products. Unfortunately, our efforts to provide safe equipment can be wiped out by an operator's single careless act.

In addition to the design and configuration of equipment, hazard control and accident prevention are dependent upon the awareness, concern, judgment, and proper training of personnel involved in the operation, transport, maintenance and storage of equipment.

It has been said "The best safety device is an informed, careful operator." We ask you to be that kind of operator.

## WARNING

- Operators must be instructed in and be capable of the safe operation of the equipment, its attachments and all controls. Do not allow anyone to operate this equipment without proper instructions.
- Never allow children or untrained persons to operate equipment.

## CAUTION

- If you do not understand any part of this manual and need assistance, see your dealer.
- Always wear relatively tight and belted clothing to avoid entanglement in moving parts. Wear sturdy, rough-soled work shoes and protective equipment for eyes, hair, hands, hearing and head.

## WARNING

- Make sure spring-activated locking pin or collar slides freely and is seated firmly in tractor PTO spline groove.
- Before starting tractor, check all equipment driveline guards for damage and make sure they rotate freely on all drivelines. Replace any damaged guards. If guards do not rotate freely on drivelines, repair and replace bearings before operating.
- A minimum 20% of tractor and equipment weight must be on tractor front wheels with attachments in transport position. Without this weight, tractor could tip over causing personal injury or death. The weight may be attained with a loader, front wheel weights, ballast in tires or front tractor weights. Weigh the tractor and equipment. Do not estimate.

## WARNING

- Make sure all safety decals are installed. Replace if damaged. (See Safety Decals section for location.)
- Make sure shields and guards are properly installed and in good condition. Replace if damaged.
- Do not allow bystanders in the area when operating, attaching, removing, assembling, or servicing equipment.
- Never walk, stand or place yourself or others under a raised wing or in the path of a lowering wing. Hydraulic system leak down, hydraulic system failures, mechanical failures or movement of control levers can cause wings to drop unexpectedly and cause severe injury or death.
- Keep bystanders away from equipment.
- Never go underneath equipment lowered to the ground or raised, unless it is properly blocked and secured. Never place any part of the body underneath equipment or between moveable parts even when the engine has been turned off. Hydraulic system leak down, hydraulic system failures, mechanical failures or movement of control levers can cause equipment to drop or rotate unexpectedly and cause severe injury or death. Follow Operator's Manual instructions for working underneath and blocking requirements, or have work done by a qualified dealer.
- Keep hands, feet, hair and clothing away from equipment while engine is running. Stay clear of all moving parts.
- Never allow riders on power unit or attachment.
- Power unit must be equipped with ROPS or ROPS CAB and seat belt. Keep seat belt securely fastened. Falling off power unit can result in death from being run over or crushed. Keep foldable ROPS systems in "locked up" position at all times.

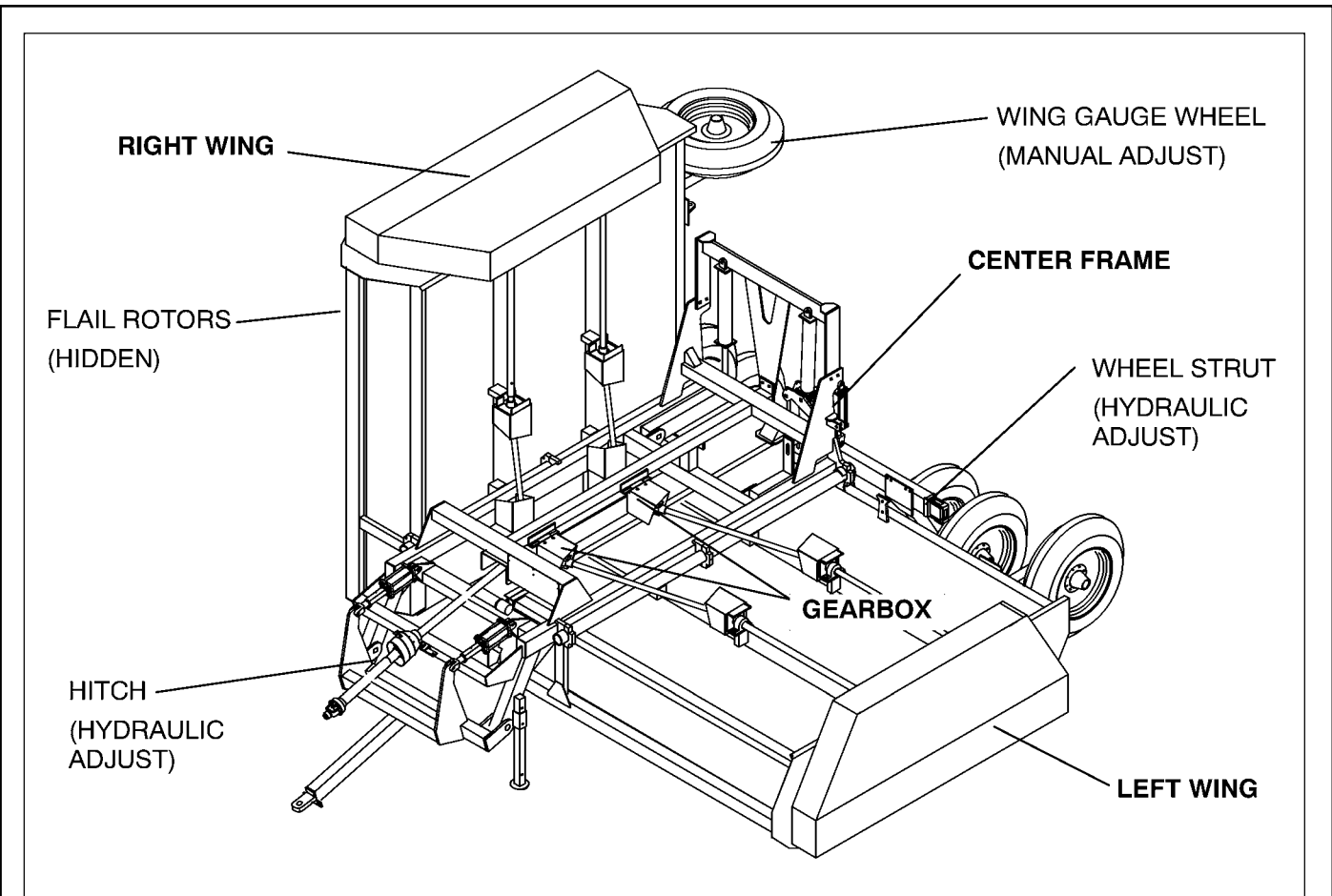
## CAUTION

- Operate only in daylight or good artificial light.
- Always comply with all state and local lighting and marking requirements.

## DANGER

- Avoid contact with electrical wires.

## Operation Continued



**Figure 1. Principal Components**

### PRINCIPAL COMPONENTS

The Alloway Folding Defoliator is built as three major components.

- a) Right Wing Assembly
- b) Left Wing Assembly
- c) Center Frame

The center frame is supported by hydraulically adjustable wheel struts and the hydraulically adjustable hitch. The main driveline and two gearboxes are mounted to the center frame.

Each wing assembly holds three flail rotor assemblies, their drive components, and a manually adjustable wing gauge wheel.

Optional scalper attachments can be mounted directly to each wing assembly.

Optional rear wheel steering struts are available.

### PRE-OPERATION CHECK LIST

(OWNER'S RESPONSIBILITY)

To assure safe and efficient operation, it is essential that each machine operator read and understand the operating procedures and related safety requirements outlined in this manual.

Complete the Pre-Operation Check List after the first hour of field operation and before each shift thereafter.

- \_\_\_ Keep Operator's Manual in storage tube for ready reference and use.
- \_\_\_ Review and follow all safety rules and safety decal instructions on pages 5 through 12.
- \_\_\_ Check that all safety decals are installed and in good condition. Replace if damaged.
- \_\_\_ Check that all shields and guards are properly installed and in good condition. Replace if damaged.
- \_\_\_ Check that all hardware and cotter pins are properly installed and secured.
- \_\_\_ Check the condition of all flails and check that they swing freely. Replace any damaged or broken flails.

## Operation Continued

### PRE-OPERATION CHECK LIST

(OWNER'S RESPONSIBILITY) *Continued*

#### IMPORTANT

■ **This Pre-Operation Check List is provided for the operator. It is important to follow for both personal safety and maintenance of the Folding Defoliator.**

- \_\_\_ Check the condition of the scalpers. Adjust or repair as required.
- \_\_\_ Check tire pressures. Service as necessary.
- \_\_\_ Check that equipment is properly and securely attached to tractor.
- \_\_\_ Make sure driveline spring-activated locking collar slides freely and is seated firmly in tractor PTO spline groove.
- \_\_\_ Before starting tractor, check all equipment driveline guards for damage and make sure they rotate freely on all drivelines. Replace any damaged guards. If guards do not rotate freely on drivelines, repair and replace bearings before operating.
- \_\_\_ Do not allow riders.
- \_\_\_ Check and keep all bystanders away from equipment working area.
- \_\_\_ Check the condition of all drive belts. Tension or align as required. Replace any that are frayed or broken.

- \_\_\_ Check all lubrication points and grease as instructed in "Service, lubrication information". Make sure the PTO slip joint is lubricated and that the gearbox fluid levels are correct.
- \_\_\_ Set tractor PTO at correct rpm for your equipment.
- \_\_\_ Check that all hydraulic hoses and fittings are in good condition and not leaking before starting tractor. Check that hoses are not twisted, bent sharply, kinked, frayed or pulled tight. Replace any damaged hoses immediately.
- \_\_\_ Raise and lower equipment to make sure air is purged from hydraulic cylinders and hoses.
- \_\_\_ Make sure tractor 3-point lift links do not interfere with hydraulic hoses or driveline throughout full turning range.
- \_\_\_ Make sure tractor ROPS or ROPS CAB and seat belt are in good condition. Keep seat belt securely fastened during operation to prevent falling off.
- \_\_\_ Before starting engine, operator must be in tractor seat with seat belt fastened. Place transmission in neutral or park, engage brake and disengage tractor PTO.
- \_\_\_ Check that rubber flaps are in good condition, pivot freely, and hang without gaps.

### Break-in of the Folding Defoliator

The following should be observed when operating the unit for the first time:

1. Attach PTO shaft. Remove grease zerks to gain access to the set screws for tightening on unit.

#### After operating for 1/2 hour or after completing five acres

2. Check all nuts, bolts, and other fasteners. Tighten to specifications given in the Bolt Torque Chart, page 66.
3. Check and re-torque on flail mounting bracket fasteners
4. Tighten wheel bolts to specifications given in the Bolt Torque Chart, page 66.
5. Check that the flails are in good condition and swing freely,
6. Check oil level in the gearbox. Add oil as required.
7. Check that the PTO driveline shield turns freely.
8. Lubricate all grease points.

#### After operating for 5 hours

9. Repeat Steps 1 through 6 above.
10. Check the tension of the drive belts. Refer to the Service and Maintenance section for the procedure. Adjust as required.

#### After operating for 10 hours

11. Repeat steps 1 through 6.
12. Check tension of drive belts. Adjust as required.

#### After operating for 15, and 20 hours

13. Check tension of drive belts. Adjust as required.



## Operation Continued

### EQUIPMENT MATCHING

Use only a tractor with adequate power and weight to operate this Defoliator. The following specifications are guidelines for a proper match.

### PTO

Tractor must be equipped with a 1000 RPM PTO. The Defoliator driveline can be ordered with a tractor yoke that matches a 1-3/8" 21-spline shaft or a 1-3/4" 20-spline shaft. Carefully measure PTO driveline in operating positions to ensure that there is proper engagement between male and female shaft to prevent the driveline from coming apart or bottoming out. Standard PTO driveline must not be shorter than 53.75" or longer than 82.88" in any position during operation, as shown in Figure 2.

### WARNING

- Connect PTO driveline directly to tractor PTO shaft. Never use adapter sleeves or adapter shafts. Adapters can cause driveline failures due to incorrect spline or incorrect operating length and result in personal injury or death.

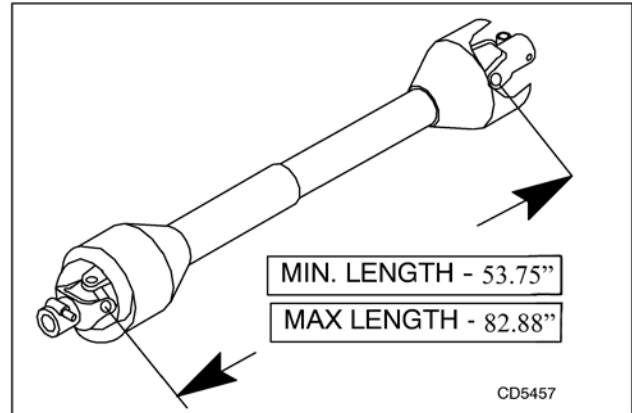


Figure 2. PTO Driveline Operating Length

### CV Driveline Turning Limits

You must not exceed a turning angle of 80 degrees at the head of the Constant Velocity driveline or damage will occur.

### IMPORTANT

- The CV PTO shaft allows the operator to make relatively short turns at the end of the field, without disengaging the PTO drive. However do not make turns tighter than 80 degrees off the straight position. If turning radius exceeds 80 degrees, disengage tractor PTO before starting the turn.

### Hydraulic System

The tractor hydraulic system must be capable of supplying 8 gpm (22 lpm) at 2000 psi (13,900 kPa). The tractor must be equipped with a minimum of three operator controlled hydraulic remote valves (one additional valve is required if optional rear steering is used).

Use #1 tractor remote valve to supply hydraulic power for the rear lift cylinders.

Use #2 tractor remote to supply hydraulic power for the front lift cylinders.

Use #3 remote valve to supply hydraulic power for the wing lift cylinders.

Use #4 remote valve to supply hydraulic power for the optional rear steering cylinder.

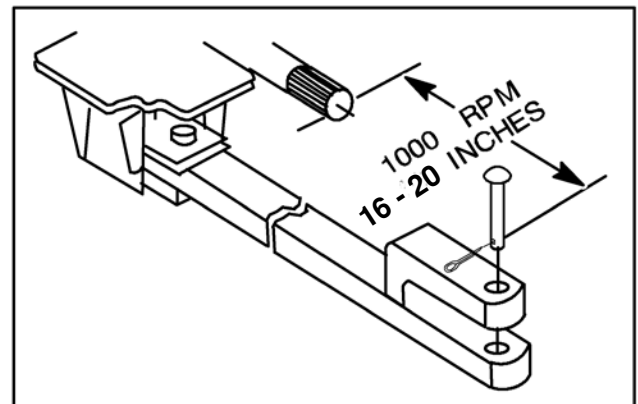


Figure 3. Drawbar Dimensions

### Drawbar with Clevis

The tractor drawbar must be set to provide 16 - 20" (406 mm - 508 mm) between the end of the PTO shaft and the center of the drawbar pin. A tractor manufacturer's clevis hitch (hammer strap and hitch pin) must be installed

## Operation Continued

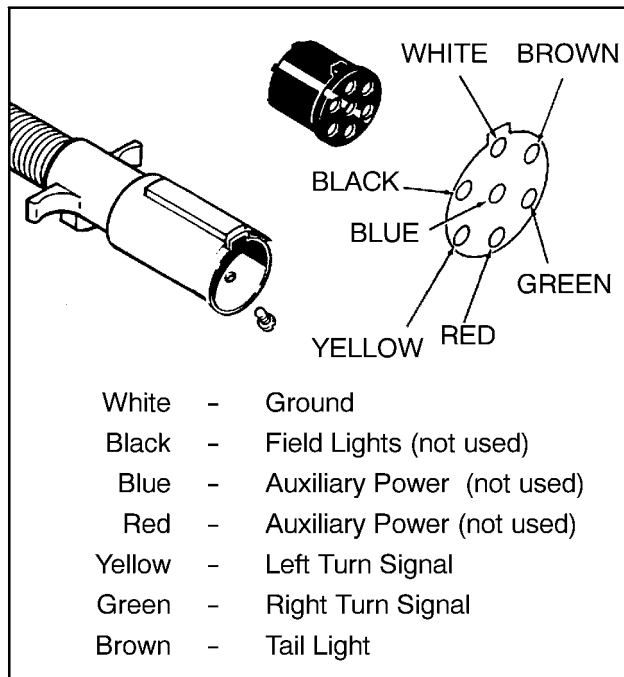
### Electrical System (Figure 5)

The tractor must be equipped with a SAE J560a 7-pin electrical connector. When connected to the Defoliator, turn signals and warning flashers will operate with the tractor lighting system.

The Defoliator is equipped with warning flashers and turn signals located on each rear corner of the center frame. Warning lights must be functional whenever the Defoliator is transported on public highways.

See your tractor operator manual for instructions on warning light and turn signal operation.

If warning lights and turn signals do not function correctly, see your Alloway dealer.



**Figure 5.** 7-Pin Electrical Connector (Defoliator End)

### Tractor Ballast

The tractor should be equipped with manufacturer's maximum allowable front end ballast for operational and transport stability.

### PROPERLY MOUNT AND DISMOUNT TRACTOR

Proper safety procedures should be followed when mounting tractor. The operator should be in the tractor seat with the seat belt securely fastened and any foldable ROPS system should be in the "locked-up" position before starting the engine or operating any controls.

Whenever the operator is required to leave the tractor seat, follow proper safety procedures. The "proper dismantling procedure" is to stop the engine, set brakes, remove the ignition key, and wait for all moving parts to stop before removing seat belt to dismount. After dismantling the tractor, secure wheels with chocks.

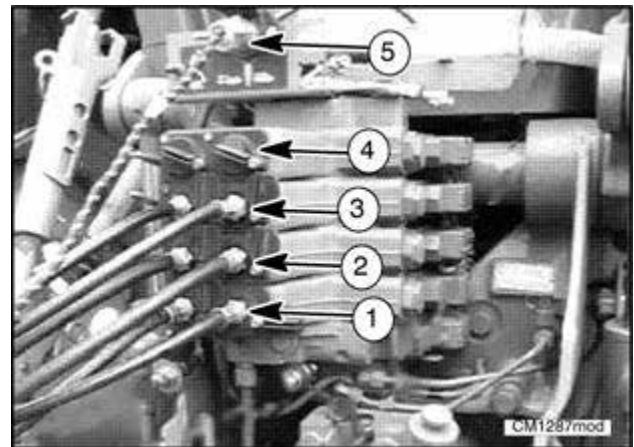
### ATTACHING DEFOLIATOR TO TRACTOR (Figure 6 through Figure 12)

**Note:** The following procedure presumes that the Defoliator is in "STORED POSITION" as described on page 23, with rear wheel/lift cylinder locks installed.

Make sure there are no bystanders between tractor and Defoliator or in the area.

Carefully back up until the tractor drawbar aligns with the Defoliator hitch.

Stop engine, set parking brake, wait for all moving parts to stop, and remove ignition key before dismantling.



1. Tractor hydraulic valve #1 (Rear Wheel/lift cylinders)
2. Tractor hydraulic valve #2 (Front hitch/lift cylinders)
3. Tractor hydraulic valve #3 (Wing lift cylinders)
4. Tractor hydraulic valve #4 (Optional rear steering)
5. 7-Pin electrical connector

**Figure 6.** Tractor Connection (Typical)

Clean the hydraulic couplers and fittings to avoid oil contamination.

Connect the hydraulic hoses which control the front hitch/lift cylinders to remote valve #2 hydraulic

## Operation Continued

couplers on the tractor. Connect these hoses so that moving the operator control lever forward lowers the Defoliator (raises the hitch tongue) and moving the operator control lever rearward raises the Defoliator (lowers the hitch tongue).

From the tractor seat, hydraulically position the height of Defoliator hitch and back up the tractor to allow the tractor clevis to align with the Defoliator hitch.

Stop engine, set parking brake, wait for all moving parts to stop, place all controls in neutral, and remove key before dismounting the tractor.

Install tractor manufacturer's clevis hitch pin and secure with tractor manufacturer's lock mechanism.

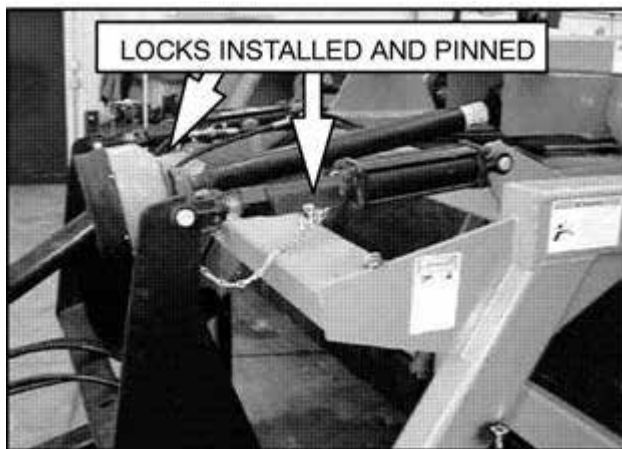
Attach the safety chain to the drawbar support of the tractor.

Insert the 7-pin male Defoliator electrical cable into the tractor female connector. Route electrical wires to prevent chafing, abrasion, or contact with rotating components.

Connect hydraulic hoses to tractor hydraulic couplers as shown in Figure 6.

Hydraulically raise the Defoliator, stop engine, set park brake, and wait for all moving parts to stop, and remove ignition key before dismounting.

Install cylinder locks on front hitch/lift cylinders.

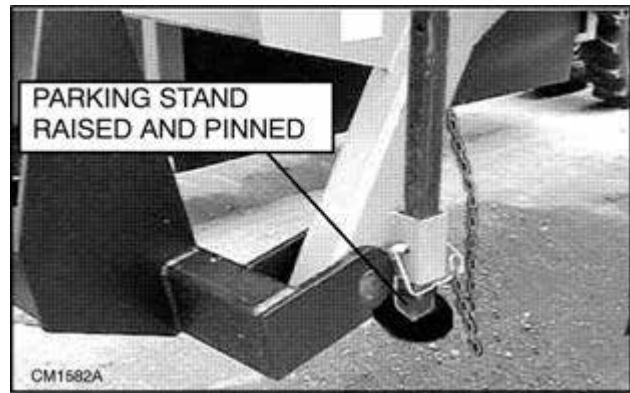


**Figure 7.** Front Hitch/Lift Cylinder Locks (Installed)

Raise parking stands and secure in raised position, Figure 8. Make sure all cylinder locks are in place.

Check that all PTO driveline guards are in place and that driveshaft telescopes correctly. Attach PTO driveshaft to tractor and make sure locking pin or collar is fully engaged.

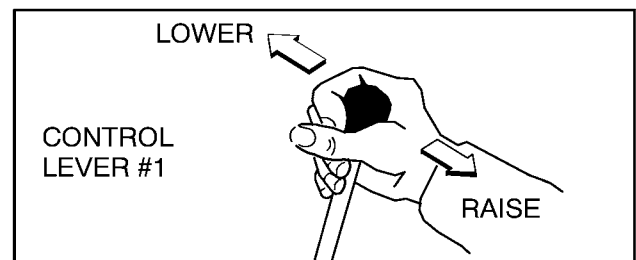
Verify that all tractor hydraulic control lever movements are correct before operating or transporting the Defoliator.



**Figure 8.** Parking Stand in Raised Position (Left Side Shown)

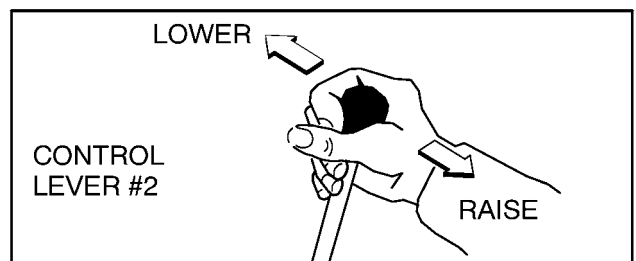
### Verification of Control Movements

Comply with all Safety Rules and start the tractor. Check that all tractor hydraulic control lever movements operate the Defoliator correctly as shown in Figure 9 through Figure 12.



- Handle forward - Lower Rear of Defoliator
- Handle back - Raise Rear of Defoliator

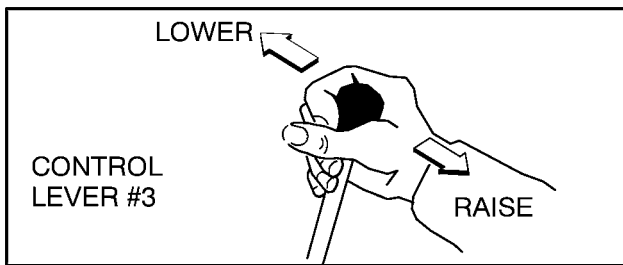
**Figure 9.** Rear Wheel/Lift Cylinders



- Handle forward - Lower Front of Defoliator
- Handle back - Raise Front of Defoliator

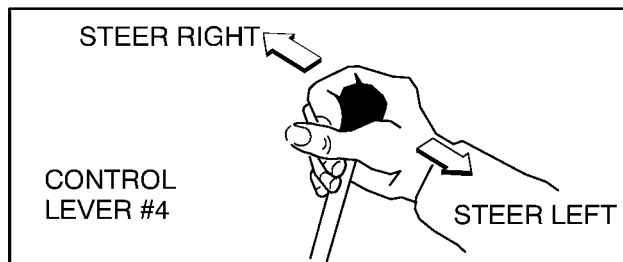
**Figure 10.** Front Hitch/Lift Cylinders

## Operation Continued



- Handle forward - Lower Wings to Operating Position
- Handle back - Raise Wings to Transport Position

**Figure 11.** Wing Raise/Lower Cylinders



- Handle forward - Defoliator Steers to Right
- Handle back - Defoliator Steers to Left

**Figure 12.** Rear Steering Cylinders (Optional)

Defoliator movements must be correct before proceeding with field operation. If movements are not correct, recheck all hydraulic coupler connections.

### DISCONNECTING DEFOLIATOR FROM TRACTOR

After following the instructions for "Disconnecting Defoliator from Tractor" the Defoliator will be in "STORED POSITION." In "STORED POSITION," Defoliator wings must be lowered to rest on wing gauge wheels, rear wheel/lift cylinder locks installed, both parking stands lowered, front hitch in lowered position, PTO driveline in storage bracket, and unit parked on a hard level surface.

Always be aware of hydraulic system leak-down. Never place any part of your body underneath equipment or between moveable parts.

Check that park stands, park stand brackets, park lockpins, and lockpin retaining chains are in good condition. Replace any missing or damaged park stand component immediately.

Park Defoliator on a hard level surface.

If Defoliator wings are in the raised transport position, carefully lower wings as instructed in "LOWERING WINGS to OPERATING POSITION"

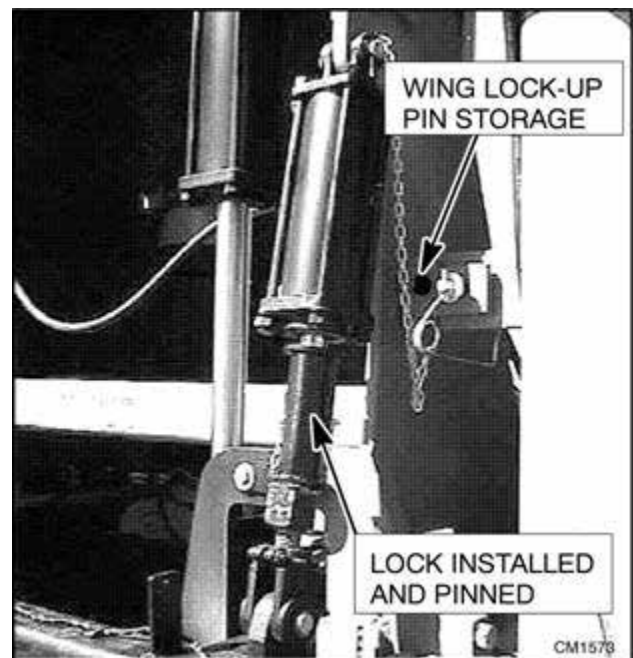
Stop the engine, set brakes, remove ignition key, and wait for all moving parts to stop before dismounting.

Set and secure parking stands in lowered position (Figure 13).



**Figure 13.** Parking Stand in Lowered Position (Right Side Shown)

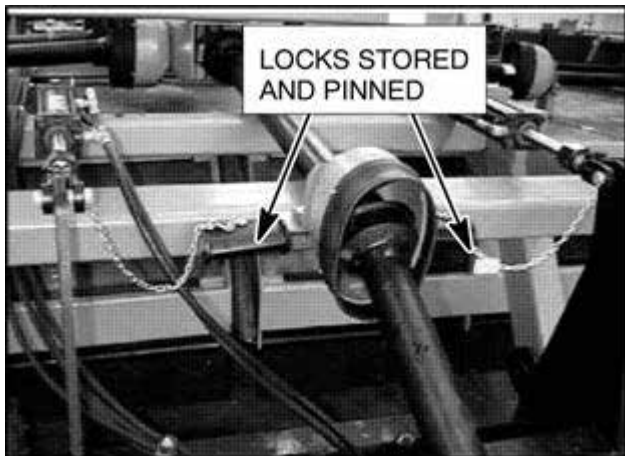
Insure that rear cylinder locks are installed as shown in Figure 14.



**Figure 14.** Rear Wheel/Lift Cylinder Lock

## Operation Continued

Front cylinder locks should be in storage position as shown in Figure 15.



**Figure 15.** Front Hitch/Lift Cylinder Lock Storage (Front)

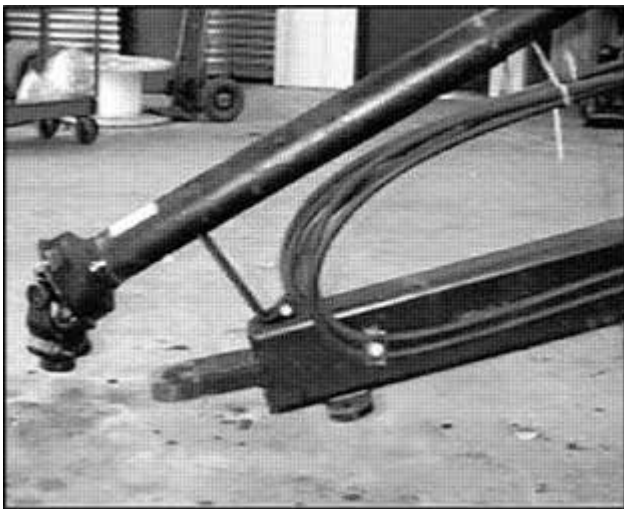
Lower Defoliator to rest on rear cylinder locks and parking stands. Raise hitch slightly from tractor drawbar so that drawbar pin can be removed.

Stop engine, set parking brake, remove ignition key, and wait for all moving parts to stop before dismantling.

Remove drawbar pin.

Disconnect PTO from tractor shaft and place PTO on PTO storage rest, Figure 16. Carefully drive tractor ahead far enough to disengage hitch from tractor drawbar.

Disconnect hydraulic lines and electrical connector.



**Figure 16.** PTO Rest

## RAISING WINGS TO TRANSPORT POSITION

### **WARNING**

- **Never walk, stand or place yourself or others under a raised wing or in the path of a lowering wing. Hydraulic system leak down, hydraulic system failures, mechanical failures or movement of control levers can cause wings to drop unexpectedly and cause severe injury or death.**

### **CAUTION**

- **Before raising or lowering wings, front hitch/lift and rear wheel/lift cylinders must be fully extended and all four cylinder locks installed. This prevents rotor and bearing support damage that can result from ground contact.**

When raising wings to transport position, the Defoliator must be securely attached to the tractor with front hitch/lift and rear wheel/lift cylinder locks installed as shown in Figure 7 and Figure 14.

Make sure that wing lock-up pins are in their storage positions as shown in Figure 14.

Fully raise front and rear of Defoliator and move tractor control lever #3 to raise wings to transport position.

Stop engine, set parking brake, wait for all moving parts to stop, and remove ignition key before dismantling.

Install wing lock-up pins as shown in Figure 17.

Check that the hitch is securely attached to the tractor drawbar and the safety chain is properly fastened.

Lower hydraulic cylinders to rest on cylinder locks.

## Operation Continued

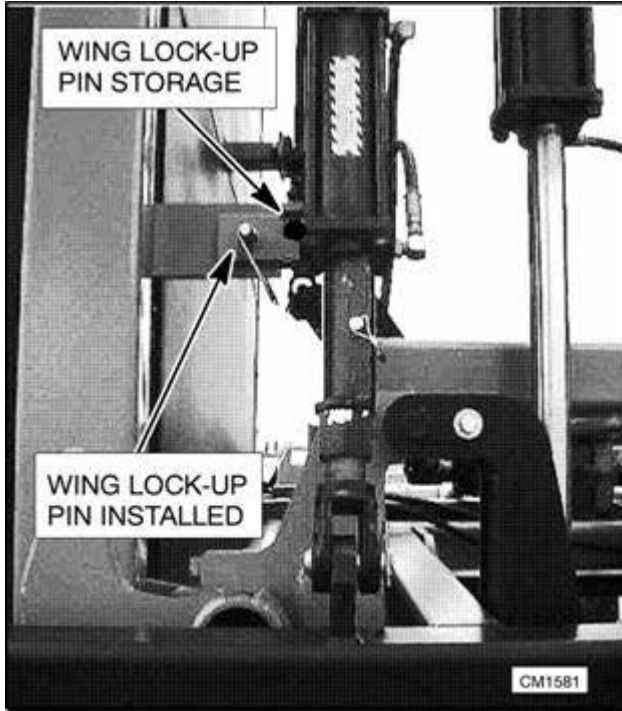


Figure 17. Wing Lock-Up Pin Installation

### LOWERING WINGS TO OPERATING POSITION

#### WARNING

- Never walk, stand or place yourself or others under a raised wing or in the path of a lowering wing. Hydraulic system leak down, hydraulic system failures, mechanical failures or movement of control levers can cause wings to drop unexpectedly and cause severe injury or death.

#### CAUTION

- Before raising or lowering wings, front hitch/lift and rear wheel/lift cylinders must be fully extended and all four cylinder locks installed. This prevents rotor and bearing support damage that can result from ground contact.

When lowering wings to operating position, the Defoliator must be properly attached to the tractor on level ground, with front hitch/lift and rear wheel/lift

cylinder locks installed and pinned as shown in Figure 7 and Figure 14.

Use tractor hydraulic lever #3 to relieve pressure on wing lock pins.

Stop engine, set parking brake, wait for all moving parts to stop, and remove ignition key before dismounting.

Remove wing lock-up pins and place in storage position as shown in Figure 18.

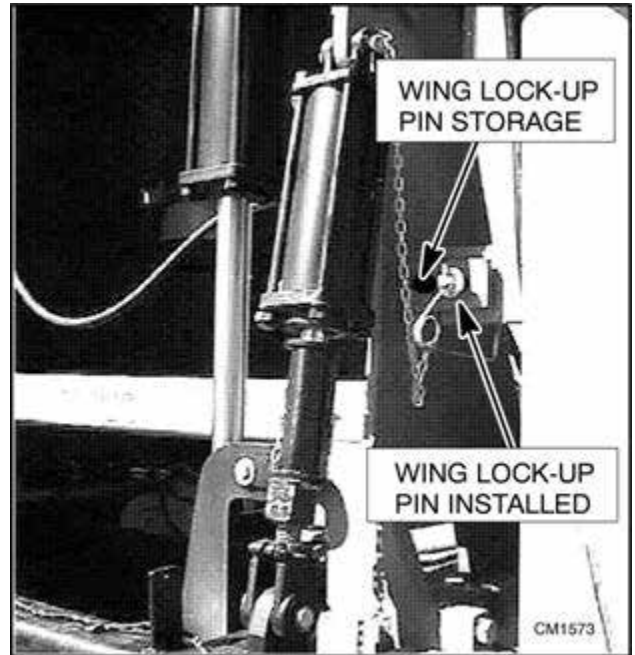


Figure 18. Wing Lock-Up Pin (Installed)

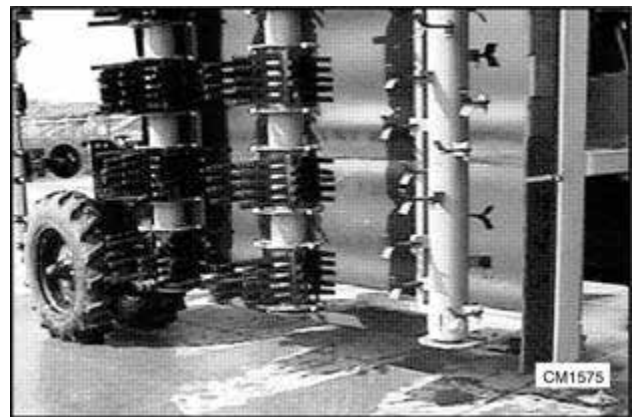
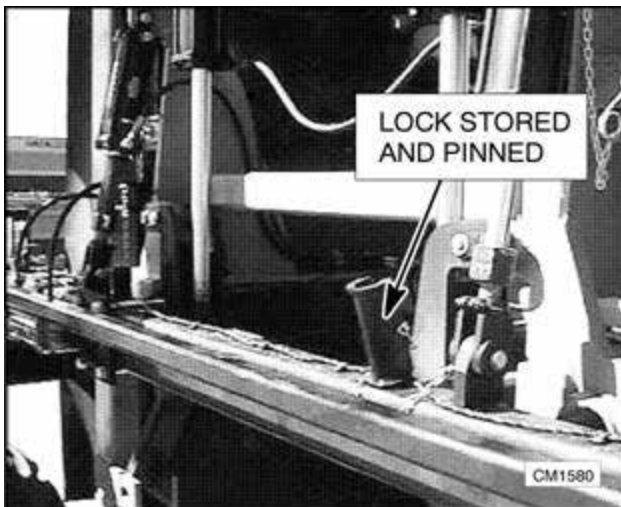


Figure 19. Inside Flail Tube Brackets

Lower the wings to rest the wing gauge wheels on the ground. Retract wing cylinders completely to allow wings to follow ground contour during operation.

**Note:** Pull ahead several feet to help align wing wheels before making final field adjustments.

## Operation Continued



**Figure 20.** Rear Wheel/Lift Cylinder Lock Storage

### FIELD OPERATION

The Alloway Defoliator will give best performance if it is properly set to work in existing conditions.

### IMPORTANT

- **Field conditions may require additional fine adjustment since tractor tracks are usually lower from cultivating and other previous field operations.**

Machine setting may require adjustment within or between fields as conditions change. Changes in soil moisture, soil density or even beet varieties may affect performance.

Defoliator must be adjusted so that wheels are centered between rows and rubber flail assemblies are centered over beet rows. All flail tips should be about 1/2" above the ground.

Before entering the field initially, the machine should be unfolded on firm and level ground.

### Leveling the Defoliator

Place Defoliator wings in operating position.

Remove front hitch/lift and rear wheel/lift cylinder locks.

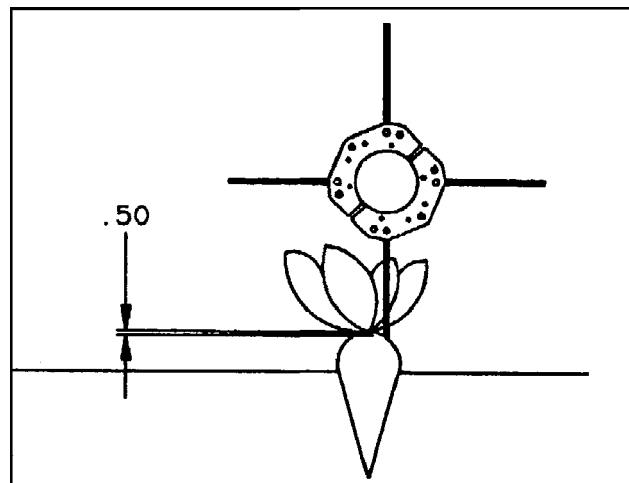
Lower rear of machine until the rubber flail tips contact the beets 1/2" below the crown.

Lower the front of the machine until the Defoliator wings are parallel to the ground. Adjust front hitch/lift and rear wheel/lift cylinder stop collars (Figure 21) to establish the operating position of the center frame. Fine adjustment may be required to match field conditions.

Adjust wing gauge wheels so that wings are level across the beet tops.

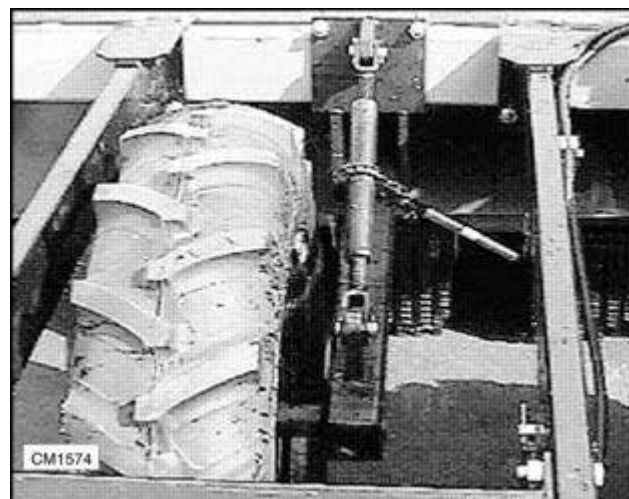


**Figure 21.** Rear Wheel/Lift Cylinder Stop Collars (Front Hitch/Lift Collars are Similar)



**Figure 22.** Leveling Defoliator

Adjust the ratchet jacks on each gauge wheel strut to level the wings and establish flail cutting height.



**Figure 23.** Gauge Wheel Ratchet Jack

## Operation Continued

On machines equipped with steel flail front rotor, the steel flail tips are 4" shorter than the rubber flail tips. Steel flails should remove only greens and not damage beet crowns, while rubber flails remove the residual foliage and deposit leaves between the beet rows.

Machines may be equipped with rubber flails on all rotors. The load of leaf removal should be split between the #1 and #2 rotor. For that reason fewer flails are used on the #1 rotor.

### Entering the Field

Pull into the field with the tractor centered on the first set of rows.

Lower the machine front and rear to the pre-set position. Scalpers will automatically lower after the rear depth control cylinders bottom out.

### Starting Defoliator

With the tractor engine at idle, slowly engage the PTO and choose your forward speed setting. Recommended speed in average conditions is 2 to 3 mph.

Increase engine speed to PTO speed.

Release clutch and move tractor forward following the beet rows.

If the performance of the Defoliator is not satisfactory, stop the unit and make any necessary adjustments.

### Stopping Defoliator

Reduce engine speed and depress clutch. Take tractor out of gear. After engine has slowed to idle, disengage PTO.

### IMPORTANT

- **Never disengage PTO at high RPM because the inertia of the turning rotors in the Defoliator can damage the tractor PTO brake.**

Stop engine, set parking brake, wait for all moving parts to stop, and remove ignition key before dismounting.

Check behind the Defoliator to observe performance.

Further fine-adjustment on wing gauge wheels and/or center carrier may be needed for satisfactory performance.

### Field Performance

Many factors will influence the performance of the

Defoliator:

- Bulk of leaf canopy
- Moisture content of foliage
- Frozen leaves
- Beet varieties
- Beet stand
- Cultivating job
- Forward speed
- Soil moisture content
- Height of beds

The operator will have to adjust the machine accordingly.

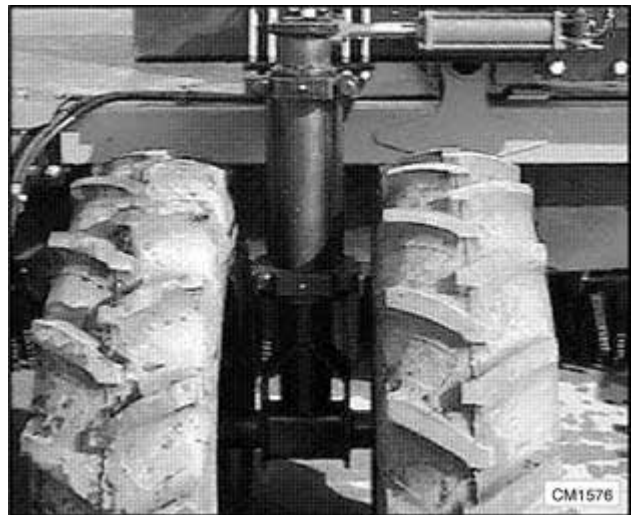
In soft or wet conditions, the tires will sink into the soil and the machine should be raised to maintain the flail contact point 1/2" below the beet crown.

In conditions where beets extend above the ground and are easily knocked over, adjust flails to contact beet at or just below the crown.

Do not allow the flails to contact the ground. Dirt, stones or other material can be thrown from under the machine.

Running the flails too low causes high flail wear and breakage, higher fuel consumption, and more build up inside the machine. Tall beets may be kicked between rows.

### Rear Steering (Optional)



**Figure 24.** Rear Steering

Optional rear wheel steering struts are used when additional maneuverability is required. Tractor must be equipped with a fourth hydraulic control lever if rear steering is to be used.



## Operation Continued

To operate the rear steering, connect hydraulic hoses so that moving the #4 control lever forward steers the Defoliator to the right and moving the #4 control lever rearward moves the Defoliator to the left.

Use the optional rear steering system to adjust the offset of the Defoliator for field operation. Ensure that rear steering is “centered” for transport and is tracking directly behind the tractor.

### Scalper Attachments (Optional)

#### **WARNING**

- Do not handle blades with bare hands. Careless or improper handling may result in serious injury.

The scalper option available from Alloway is a non-driven, mechanically rotating disc. Scalper lift cylinders operate in parallel with the rear wheel lift cylinders. When raising the rear of the Defoliator, scalper attachments will raise first. When lowering the rear of the Defoliator, scalper attachments will lower last.

#### **IMPORTANT**

- Always raise scalpers before backing up. Scalpers must be fully raised before folding wings.

The disc will rotate to either side and a sharp cutting edge is exposed to do the scalping job. When properly adjusted, it will stay free of debris and consistently cut the required amount of the beet crown.

Uneven beet stands and double beets will cause less than perfect performance. Adjustments should be made to regulate the thickness of the slice to be removed.

Forward speed changes will influence the performance.

In any working position, the disc forward edge of the disc should always be a few degrees lower than the rear edge.

Scalpers are factory pre-set, but need fine adjustment for individual conditions.

#### **CAUTION**

- Never work on scalper attachment in the raised position. Lower scalpers to the ground and service each unit individually.

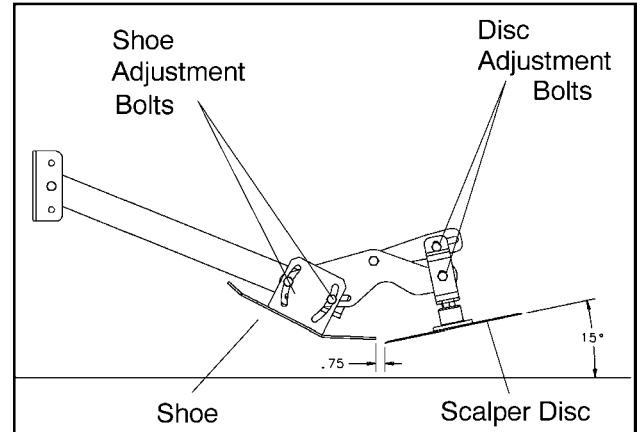


Figure 25. Scalper Adjustment

Loosen shoe adjustment bolts and adjust scalper shoe. The trailing surface of the shoe should be nearly horizontal.

Loosen disc adjustment bolts to adjust disc operating pitch. Adjust pitch of scalper disk to slice beets as required.

When adjustments are complete, tighten bolts to specifications in torque chart.



Figure 26. Scalper Attachment

### TRANSPORTING THE DEFOLIATOR

When transporting on public roads, wings must be raised to transport position. Follow instructions in “Raising Wings to Transport Position.”

Make sure reflector, lights and the SMV sign are clean and clearly visible to other traffic.

Do not allow riders.

Use hazard flashers on the tractor when transporting.

Never exceed safe travel speed. Slow down when

## Operation Continued

making turns and traveling on rough roads or shoulders.

Make sure to use a tractor of sufficient size and with enough front end ballast to assure safe steering.

Lock foot brake pedals for even application during road travel.

### DEFOLIATOR STORED POSITION

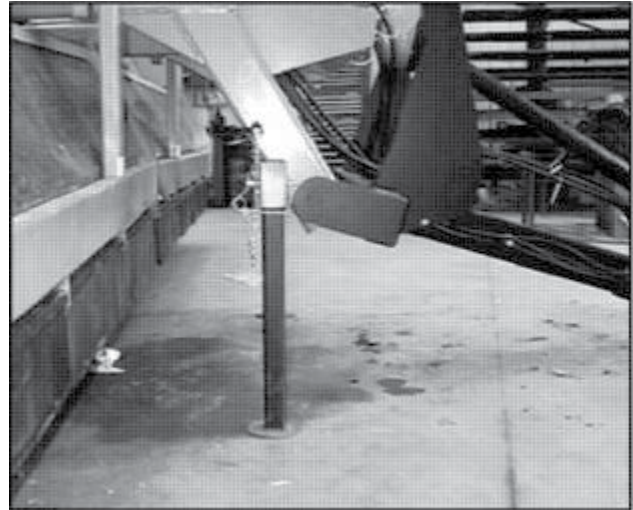
Lower wings to operating position and disconnect Defoliator from tractor as described in "Disconnecting Defoliator from Tractor." Defoliator should be in "STORED POSITION" and be supported by park stands, rear wheel/lift cylinder locks, and wing gauge wheels.

Gauge wheel screw jacks may be adjusted to support wings in a level position.

Store Defoliator in an area away from children and bystanders.

Do not allow children to play on or around the stored unit.

Store in a dry, level area.



**Figure 27.** Parking Stand

## NOTES

# OWNER SERVICE

Safety is a primary concern in the design and manufacture of our products. Unfortunately, our efforts to provide safe equipment can be wiped out by an operator's single careless act.

In addition to the design and configuration of equipment, hazard control and accident prevention are dependent upon the awareness, concern, judgement, and proper training of personnel involved in the operation, transport, maintenance and storage of equipment.

It has been said "The best safety device is an informed, careful operator." We ask you to be that kind of operator.

The information in this section is written for the operator who possesses basic mechanical skills. Should you need help, your dealer has trained service technicians available. For your protection, read and follow all safety information in this manual.

## **⚠ WARNING**

- Service and maintenance work not covered in OWNER SERVICE must be done by a qualified dealership. Special skills, tools and safety procedures may be required. Failure to follow these instructions can result in serious injury or death.
- Before working underneath a raised implement, read and follow all operator's manual instructions and safety rules. Implement must be attached to tractor, lift cylinder locks must be installed, and lift cylinders lowered against locks. Hydraulic system leak down, hydraulic system failures, or movement of control levers can cause equipment to drop unexpectedly and cause severe injury or death.
- Never perform service or maintenance with engine running.
- Do not disconnect hydraulic lines until engine is stopped, tractor is properly secured, equipment and all components are lowered to the ground, and system pressure is released by operating all valve control levers.
- Keep all persons away from operator control area while performing adjustments, service or maintenance.
- Never go underneath equipment lowered to the ground or raised, unless it is properly blocked and secured. Never place any part of the body underneath equipment or between moveable parts even when the engine has been turned off. Hydraulic system leak down, hydraulic system failures, mechanical failures or movement of control levers can cause equipment to drop or

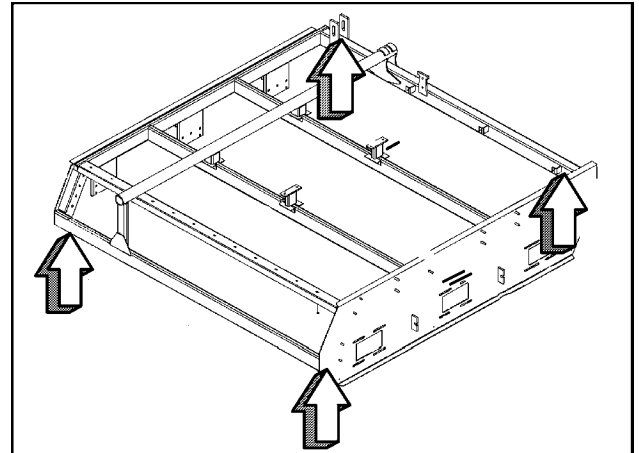
tate unexpectedly and cause severe injury or death. Follow Operator's Manual instructions for working underneath and blocking requirements, or have work done by a qualified dealer.

## **⚠ CAUTION**

- Always wear relatively tight and belted clothing to avoid entanglement in moving parts. Wear sturdy, rough-soled work shoes and protective equipment for eyes, hair, hands, hearing and head.

### **BLOCKING METHOD (Figure 28)**

Do not work underneath the Defoliator unless it is properly attached to the tractor and blocked securely. When properly attached, the unit will be anchored to minimize front-to-rear movement. Do not work on Defoliator with wings in any intermediate position.



**Figure 28** Jackstand Locations  
(Left wing shown; Right wing similar)

For any service work which requires working underneath the Defoliator, the following blocking instructions must be followed.

The Defoliator must be properly attached to a tractor located on a hard level surface.

The Defoliator wings must be lowered into operating position with wing gauge wheels adjusted to support the wings during service.

Front and rear cylinder locks must be properly installed. Do not use a cylinder lock or retaining pin which is bent or damaged. Replace any damaged or lost cylinder lock components immediately.

Jackstands, with a minimum load rating of 4000 lbs each, must be placed under the wing frames at each corner of the right and left wings as shown in Figure 28. Jackstands should be adjusted so that they securely support the Defoliator during service.

Tractor park brake must be engaged, wheels chocked, and PTO shaft disconnected from the tractor.

## LUBRICATION

### Gearbox Oil

Use 80W90 gear lube. Capacity: 2 US quarts.

### Greasing

Use a multi-purpose high temperature grease.

**Note:** Over-greasing can cause damage to bearing seals.

- a. Use hand held grease gun to avoid blown seals.
- b. Wipe grease fittings clean to avoid contamination.
- c. Replace or repair broken fittings immediately.
- d. If fittings do not take grease, remove zerk, and clean passageway.

### Sealed Bearing Information (Figure 29)

Moisture and contaminants can be trapped behind the bearing seals.

Usually a single pump of a hand held grease gun every 40 hours of operation will be sufficient to force moisture out and relube the bearing. Please keep this in mind when greasing line shaft or rotor bearings on the Defoliator.

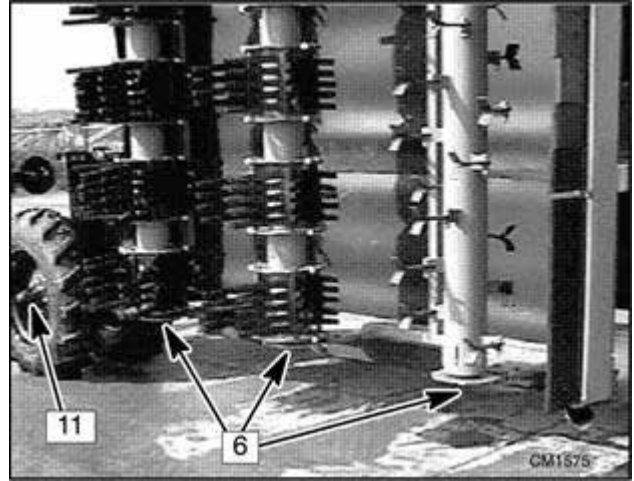


Figure 29. Inside Rotor Bearings

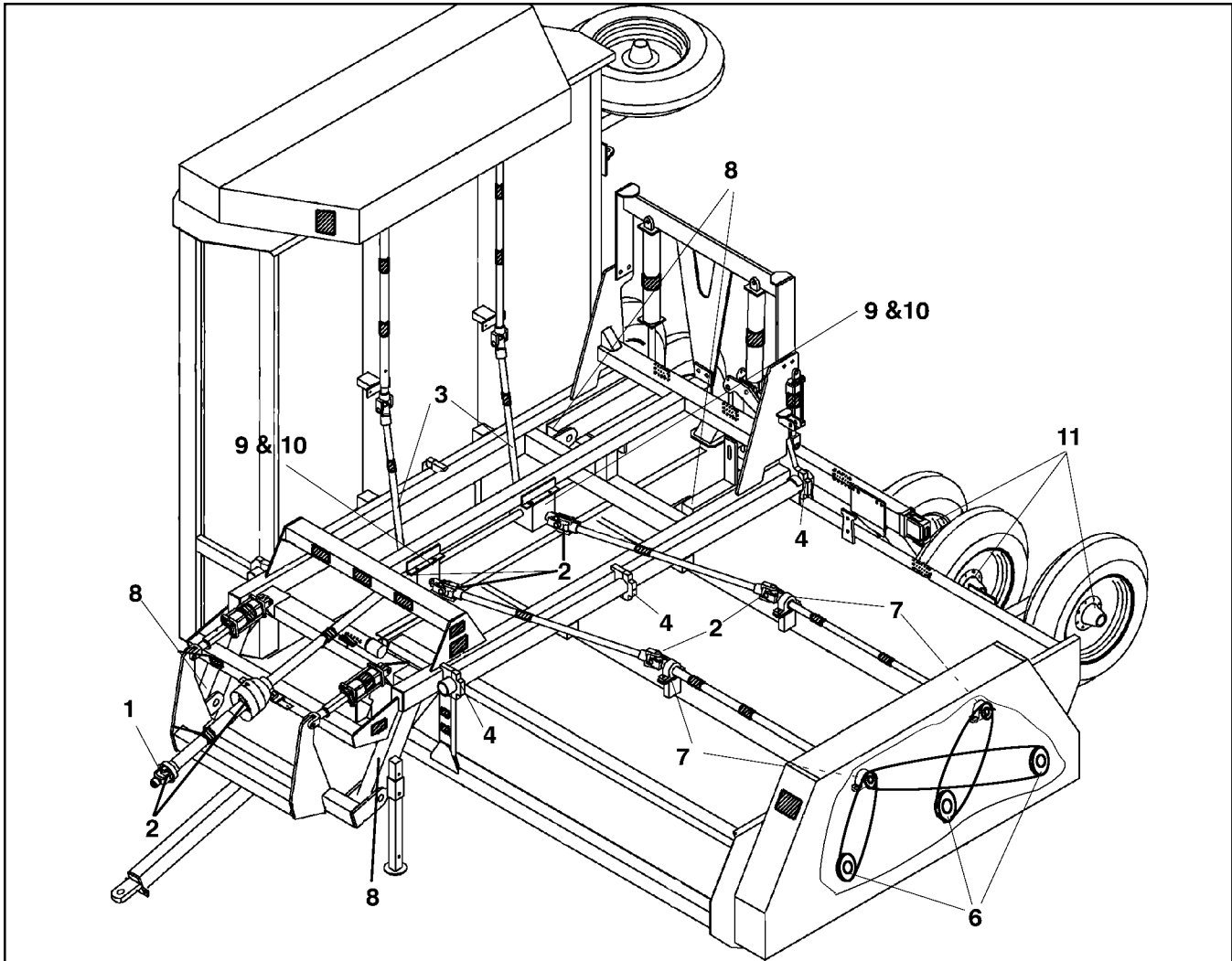


Figure 30. Lubrication Points

## Grease Intervals

(Figure 30 through Figure 32)

### 10 Hours

1. Grease CV PTO portion of the driveline.
2. Grease PTO driveline with regular universals and shield zerks.

### 20 Hours

3. Grease all telescoping drive shafts on top of the machine including shield zerks.
4. Grease wing hinge points and all lift arm linkages.

### 40 Hours

5. Grease rear steering pivots (Figure 31).
6. Grease all rotor bearings (Figure 29 and Figure 30).
7. Grease all line shaft bearings.
8. Grease hitch and rear carrier hinge points.

### Annually

9. Change oil in gearboxes.
10. Clean gearbox breathers.
11. Repack carrier wheel bearings.
12. Inspect scalper bearings.
13. Grease gauge wheel jack screws (Figure 32).

Grease all zerks after washing and at outset or end of season to remove potential moisture from bearings.

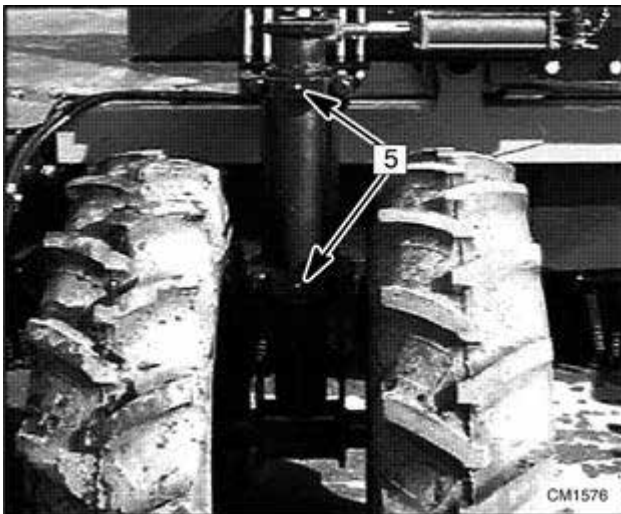


Figure 31. Rear Steering Pivots

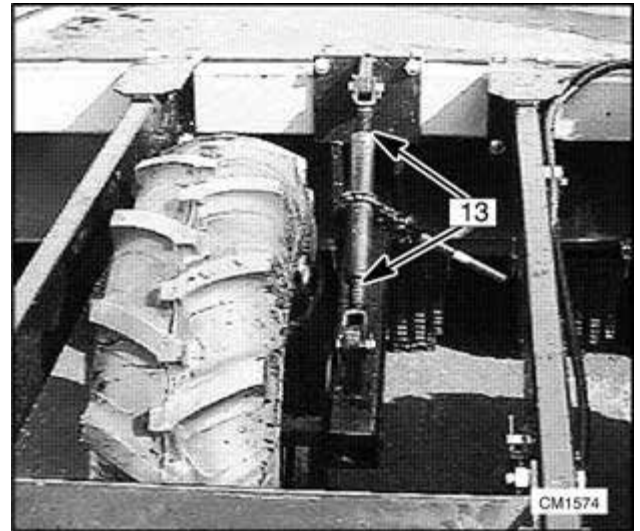


Figure 32. Gauge Wheel Jack Screws

## MAINTENANCE

### Drive Belts

#### Belt Tension

Banded drive belts are used to transmit power to the rotor shafts. Improperly adjusted belts will create heat which results in poor performance and fast belt wear. It is wise to check belts every 4 to 5 hours, if they feel cool to touch, they are adjusted well. Any high heat should signal a need for adjustment.

**Note:** Heat buildup can also be caused by running flails too close to the ground or excessive build up inside the Defoliator.

#### Adjusting Belt Tension (Figure 33)

Stop tractor engine, put all controls in neutral, remove ignition key, and wait for all moving parts to stop before dismounting.

Open and secure lower belt housing shields.

Loosen bearing plate anchor bolts (A).

Adjust nuts on tightener rod (B) until proper tension is reached.

Retighten bearing plate (A).

Close and secure belt housing shields.

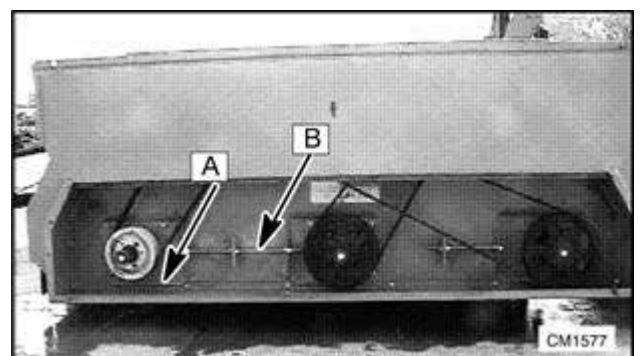


Figure 33. Belt Tension Adjustment - Belt Box

### Replacing Drive Belts (Figure 33 & Figure 34)

Stop tractor engine, put all controls in neutral, remove ignition key, and wait for all moving parts to stop before dismounting.

Open and secure lower belt housing shields.

Loosen bearing plate anchor bolts (A).

Loosen nuts on tightener rod and bring rotor shaft to the extreme loose position.

Replace belt on sheaves as shown in Figure 33 and Figure 34.

Adjust nuts on tightener rod (B) until proper tension is reached.

Retighten bearing plate (A).

Close and secure belt housing shields

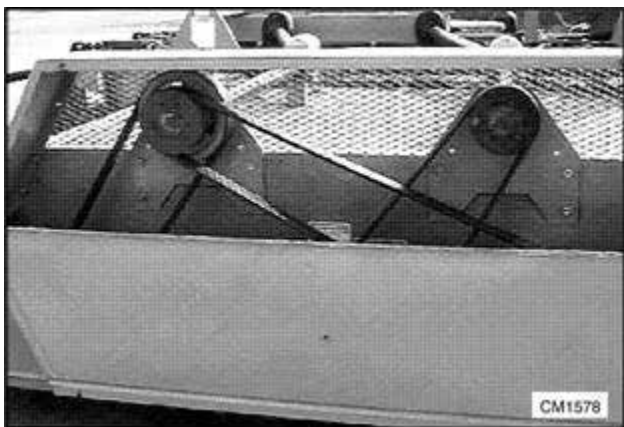


Figure 34. Rotor Upper Drive Pulleys

### Flail Replacement

Securely block-up the Defoliator as described in "Blocking Method for Defoliator Service," Figure 28.

#### **WARNING**

■ Never walk, stand or place yourself or others under a raised wing or in the path of a lowering wing. Hydraulic system leak down, hydraulic system failures, mechanical failures or movement of control levers can cause wings to drop unexpectedly and cause severe injury or death.

#### **IMPORTANT**

■ Always replace opposite pairs of knives and mounting hardware to maintain rotor balance. Replace any broken or missing knife immediately.

### L-Knife/Cup

Remove bolt from flail bracket and remove flail.

Replace flail bushing and tighten bolt to specifications in Torque Chart.

### Rubber Flail

Rubber flails are attached to adjustable flail heads, which are clamped to the rotor.

To replace rubber flails, remove flail pin retaining bolt and withdraw pin. Remove flail assembly as a unit. Head clamping bolts may need to be loosened to make disassembly easier.

Note location of flails, spacers and bushings. Replace any worn, damaged or missing components in their correct location. Insert flail pin through assembly and install retaining bolt. Tighten flail pin retaining bolt to specifications in Torque Chart.

Inspect flail heads to determine that they are securely clamped to rotor. If flail heads are not attached securely, tighten clamping bolts to specifications in Torque Chart.

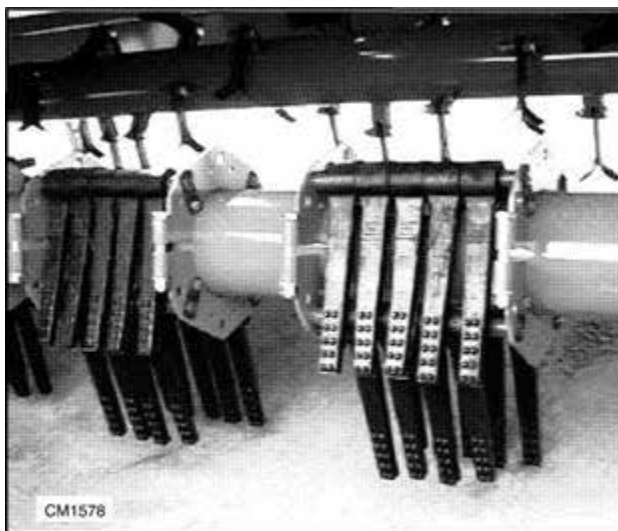


Figure 35. Flail Assembly

# TROUBLE SHOOTING

The Alloway Folding Defoliator uses rubber or steel flails on drums to remove foliage from the tops of sugar beets. It is a simple and reliable system that requires minimal maintenance. The following table lists problems, causes, and solutions that you may

encounter. If you encounter a problem that is difficult to solve even after reading through this table, please call your local Alloway dealer. When calling, please have this manual and your unit's serial number ready.

<b>PROBLEM</b>	<b>POSSIBLE CAUSE</b>	<b>SOLUTION</b>
Drums won't turn	Tractor PTO defective	Repair tractor PTO
	Broken cross shaft or drive coupler on central hanger bearing	Replace (9 or 12 row units only)
Rapid belt wear	Machine plugged	Unplug machine
	Pulleys out of alignment	Align pulleys
	Loose or overtightened belts	Adjust belt tension
	Overloaded/Running too low	Raise unit or slow down
Flails breaking	Machine too low	Raise machine
	Hitting rocks or other debris	Clean field better before planting
Tires don't turn	Mud buildup	Adjust tire pressure to 15-20 psi
Beet crown not clean	Machine too high	Lower the machine
	Flails broken	Replace broken flails
	Traveling too fast	Slow down
	Running slow (tractor)	Increase speed to rated PTO RPM
	Need a scalper	Install and set scalper
	Scalper bounces	Increase scalper spring tension
Beets are pulled out of the ground	Machine too low	Raise machine
	Machine too slow	Increase ground speed
	Scalper pulling beets out of ground	Adjust scalper
Defoliator vibrates	Driveline doesn't telescope	Remove, disassemble, and clean telescoping joint
	Flail tube out of balance	Balance tube
		Replace missing knives or rubber flails. Always replace in pairs 180 degrees apart.

# NOTES

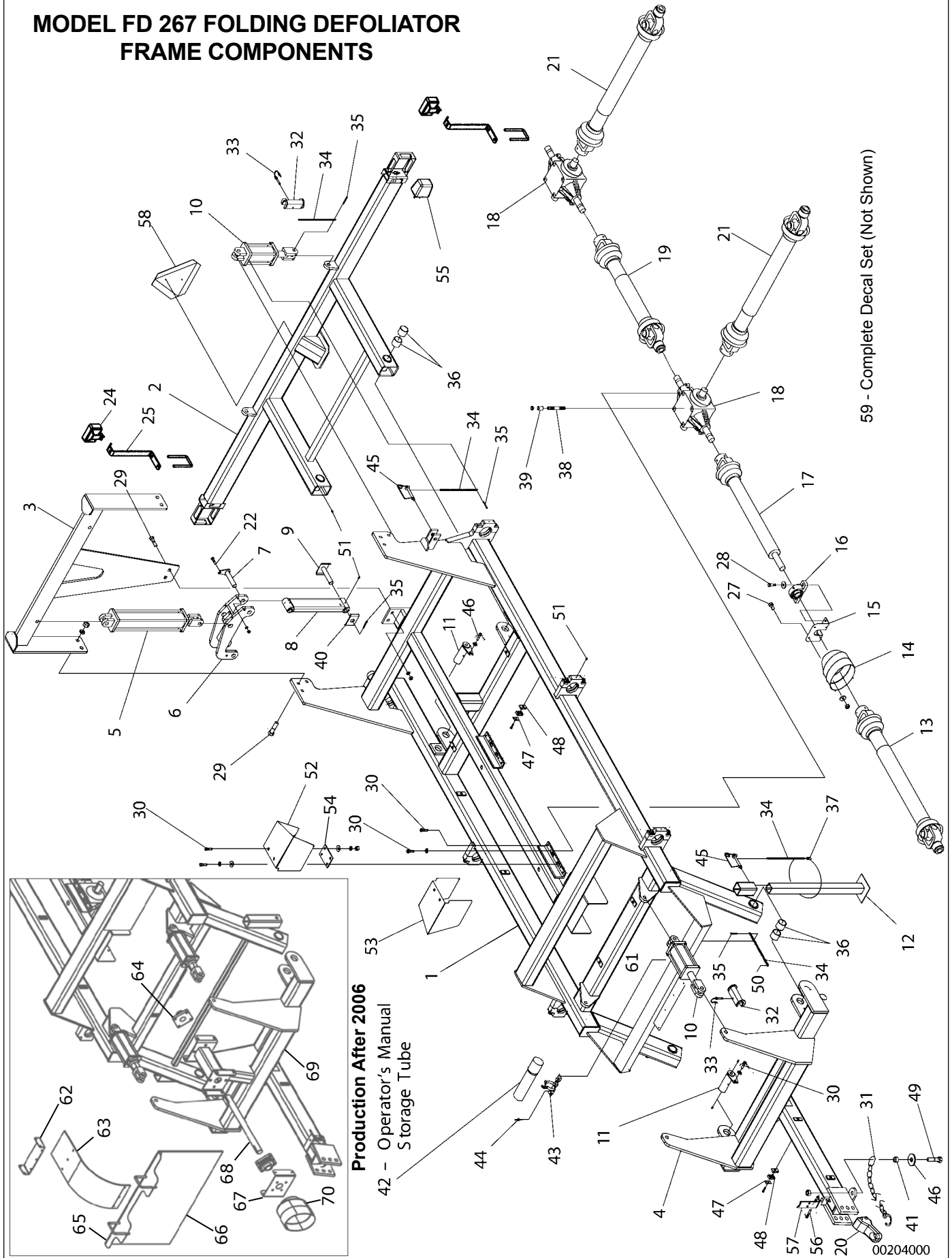
---



**FOLDING DEFOLIATOR  
FD 267**

FRAME COMPONENTS .....	32-33
WING COMPONENTS .....	34-35
STRUT COMPONENTS .....	36-37
SCALPER COMPONENTS .....	38-39
COVER COMPONENTS .....	40
FLAIL COMPONENTS .....	41
HYDRAULIC COMPONENTS .....	42-43
STABILIZER WHEEL OPTION .....	44
LIGHT COMPONENTS.....	45
GEARBOX - SUPERIOR (4-WAY) .....	46
JUMP PTO SHAFT - WEASLER.....	47
1-3/8" PTO SHAFT - WEASLER CONSTANT VELOCITY .....	48
1-3/4" PTO SHAFT - WEASLER CONSTANT VELOCITY .....	49
WING DRIVELINE .....	50
INTERMEDIATE SHAFT.....	51
OVER RUN DRIVE SHAFT.....	52
PTO SHAFT (2001-2006 PRODUCTION) .....	53

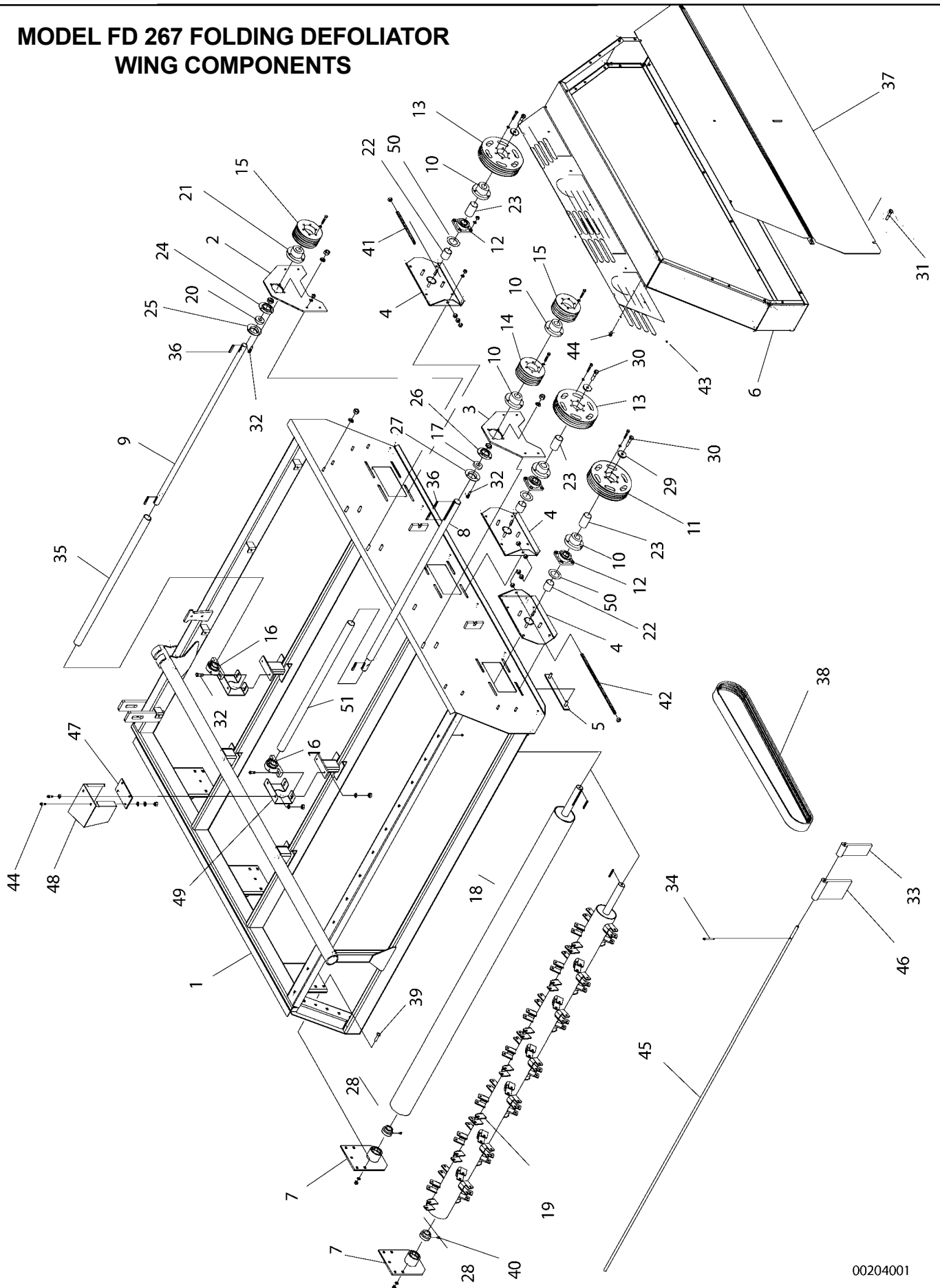
# MODEL FD 267 FOLDING DEFOLIATOR FRAME COMPONENTS



## MODEL FD 267 FOLDING DEFOLIATOR FRAME COMPONENTS

REF.	PART NO.	DESCRIPTION	QTY.
1	500-2-0664	Center Frame	1
2	500-2-0659	Strut Mount	1
3	500-2-0661	Top Bar	1
4	500-2-0663	Hitch	1
5	905-21395	Hydraulic Cylinder, 4" x 24"	2
	905-21409	Seal Kit, 4" x 24"	2
6	500-2-0662	Link Arm	2
7	500-2-0684	1-1/4" Pin	4
8	500-2-0682	Pivot Tube	2
	500-2-0954	Hydraulic Row Finder-Rigid	
9	500-2-0685	Channel Pin	2
10	905-21400	3-1/2" x 8" Cylinder	4
	905-21401	Seal Kit, 3-1/2x8	1
11	500-2-0748	Pin Weldment, Strut Mount	4
12	500-2-0658	Parking Stand	2
13		PTO Shaft, Constant Velocity (See Page 47 & 48)	1
14	903-18007	PTO Bell	1
15	700-3-0444	Front Bell Mount	1
16	901-01272	1 -3/4" Pillow Block Bearing	1
17	903-18052	Driveline (See Page 48)	1
18	903-15560	Gearbox (4 Way)	2
19	903-18198	Jump PTO Shaft (See Page 46)	1
20	505-3-0831	Hitch Tongue, Complete	1
21	903-18055	Driveline, Wing (See Page 48)	4
22	900-01225	1/2 NC x 1 -1/2 Hex Bolt, GR5	4
23	500-3-1724	Harness (Not Shown)	1
24	500-3-1721	Field Light	2
25	500-3-1720	Bracket, Field Light	2
26	100-3-3333	3/8" x 2 Key	4
27	900-01694	3/8" NC x 3/4" Carr. Bolt	20
28	900-01233	1/2" NC x 2-1/2" Hex Bolt, GR5	2
29	900-01515	1" NC x 2-1/2" Hex Bolt, GR5	2
30	900-01221	1/2"NCx1 Hex Bolt, GR5	20
31	905-07113	Tow Chain	1
32	700-2-0159	Cylinder Lock (used for Front Hitch/Lift and Rear Wheel/Lift)	4
33	900-42055	Cylinder Lock Pin	4
34	120-3-0472	Chain, PTO Hook-up	8
35	900-23045	3/16x2 Cotter Pin	8
36	901-01318	Bushing, 2-1/2 OD x 2" Long	8
37	900-42051	1/8" Quick Link	4
38	905-01238	Nipple, 1/2 NPTx 6	2
39	905-04189	Coupling, 1/2 NPT	2
40	500-3-1510	Channel Pin	2
41	505-3-0713	Spacer Bushing	1
42	100-3-3957	Manual Tube	1
43	100-3-3958	Clamp	1
44	900-21489	Pop Rivet	14
45	900-42054	Lock-up Pin (used for Wings and Parking Stand)	4
46	500-3-1631	Washer	1
47	900-31068	Cover Plate and Bolt	14
48	900-31069	Clamp Body	14
49	900-01519	1 x 3 Hex Bolt, GR5	1
50	900-17046	1/4"-28 Hex Washer Head Screw	4
51	905-15024	Zerk	14
52	500-2-0749	Gearbox Shield (LH, With safety decal)	2
53	500-2-0750	Gearbox Shield (RH, With safety decal)	2
54	500-3-1684	Rubber Hinge	2
55	904-01132	Light Assembly	2
	901-01133	Light Bulb #3157	2
	500-3-1720	Bracket, Field Bracket (Not Shown)	
56	900-01195	7/16x4 Hex Bolts, GR5	1
57	500-2-0532	PTO Rest	1
58	500-3-1696	SMV with Metal Base	1
59	500-1-0100	Complete Decal Set (Includes all Safety Decals)	1
60	500-3-1725	Sealed Beam	2
61	500-3-1718	Center Deflector (Not Shown)	1
62	500-3-2237	Deflector Shield Mount Plate	1
63	500-3-2238	Deflector Shield - Divider	1
64	901-01185	Bearing 1-3/4 107022	2
65	500-3-2211	Plate - Front Flap Mount	1
66	700-3-1220	Rubber Flap - Mud Shield	1
67	500-3-2164	Guard Bracket	2
68	500-3-2165	PTO Transfer Shaft	1
69	500-2-0663	Hitch Weldment	1
70	903-18007	PTO Bell	2

# MODEL FD 267 FOLDING DEFOLIATOR WING COMPONENTS

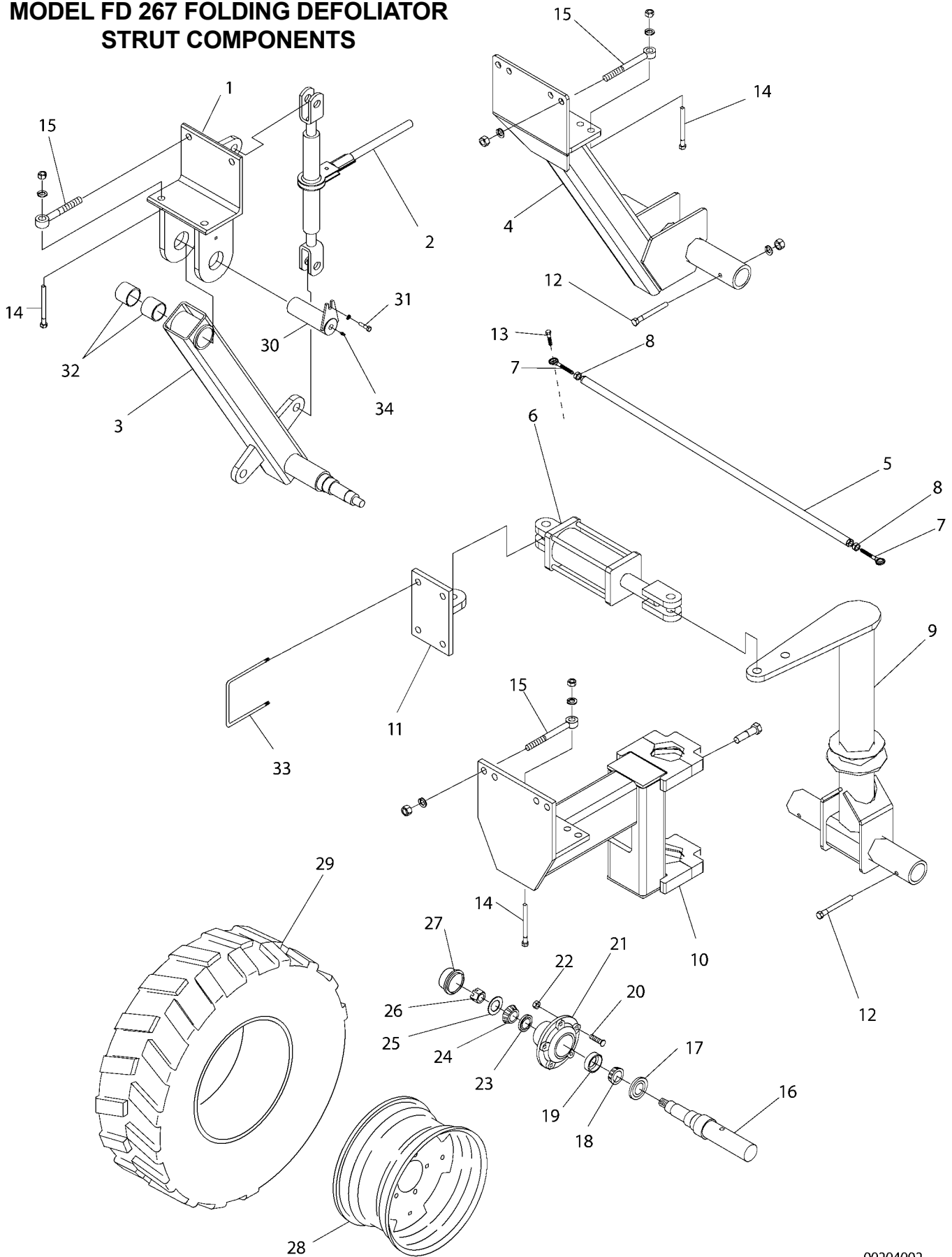


00204001

## MODEL FD 267 FOLDING DEFOLIATOR WING COMPONENTS

REF.	PART NO.	DESCRIPTION	QTY.
1	500-2-0674	Wing Weldment (RH)	1
	500-2-0673	Wing Weldment (LH)	1
2	500-3-1462	Rear Upper Plate	1
3	500-3-1461	Front Upper Plate	1
4	500-2-0672	Bearing Slide Weldment	3
5	500-2-0671	Slide Strap Weldment	6
6	500-2-0756	Side Shield Weldment (With safety decal)	1
7	500-2-0670	Mounting Plate Weldment	3
8	500-2-0757	Front Output Shaft (With safety decal)	1
9	500-2-0758	Rear Output Shaft (With safety decal)	1
10	903-08420	Hub, 2-3/16" Type E	5
11	903-08362	Pulley, 3C8.5 (Steel)	1
	903-08421	Pulley, 3C14 (Rubber)	1
12	901-01311	2-3/16" Bearing Assy.	3
13	903-08421	Sheave, 3C14	2
14	903-08363	Sheave, 3C13 (Steel)	1
	903-08362	Pulley, 3C8.5 (Rubber)	1
15	903-08362	Pulley, 3C8.5	2
16	901-01272	1 -3/4" Pillow Block Bearing	2
17	901-01309	2-3/16" Bearing	1
18	500-2-0699	Flail Drum Weld	A/R
19	500-2-0784	Flail Tube, FUD RH	1
19	500-2-0785	Flail Tube, FUD LH	1
20	901-01186	1-3/4" Insert Bearing	1
21	500-3-1061	Hub, 1-3/4" Type E	1
22	500-3-1541	Steel Spacer (2.58 Long)	3
23	500-3-1540	Steel Spacer (4.16 Long)	3
24	901-01312	Flange, 4 Hole 90 MM	1
25	901-01313	Flange, 4 Hole 90 MM (Zerk)	1
26	901-01314	Flange, 4 Hole 100 MM	1
27	90101315	Flange. 4 Hole 100 MM (Zerk)	1
28	901-01310	Bearing, 1-3/4" Insert	3
29	500-3-1463	Washer	3
30	900-01399	3/4" NCX 1-1/2" Hex Bolt	3
31	900-03467	1/2" NCX 1" Flange Whiz Bolt	4
32	900-01751	1/2" NCx1-1/2" Carr Bolt	8
33	505-3-0868	Flap, 3-1/2"	1
34	900-23034	5/32x1-1/4 Cotter Pin	1
35	500-2-0755	Shaft Shield (With safety decal)	2
36	100-3-3333	3/8" X 2" Key	5
37	500-2-0690	Door, Shield	2
38	903-01433	Belt, 3C105	A/R
	903-01434	Belt, 3C173	1
39	900-01784	5/8 NCx 1-1/2 Carr Bolt	15
40	900-03052	5/16 NF x 1/2 Socket Head Cap Screw	3
41	500-3-1629	3/4" Threaded Rod (Short)	1
42	500-3-1628	3/4" Threaded Rod (Long)	1
43	500-3-1632	Cover Inner Belt	1
44	900-01221	1/2x1 Hex Bolt, GR5	9
45	500-3-1636	Rod, Flaps	1
46	505-3-0739	Flap, 6"	42
47	500-3-1685	Rubber Hinge	2
48	500-2-0752	Pillow Block Shield (LH, With safety decal) Shown	2
	500-2-0753	Pillow Block Shield (RH, With safety decal) Not Shown	2
49	500-2-0754	Pillow Block Bracket (With safety decal)	2
50	900-11072	Narrow Rim Machine Bushing	51
51	500-2-0759	Shaft Shield (with safety decal)	2
52	500-3-2196	Wire Harness (Not Shown)	1
53	900-06630	Nut, Clip-on, 1/2"-13, Square Style, ZP	1

# MODEL FD 267 FOLDING DEFOLIATOR STRUT COMPONENTS



00204002

## MODEL FD 267 FOLDING DEFOLIATOR STRUT COMPONENTS

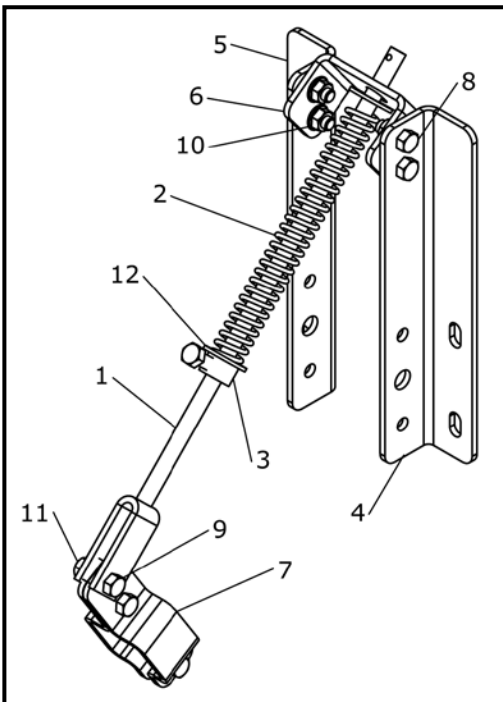
REF.	PART NO.	DESCRIPTION	QTY.
1	500-2-0686	Mounting Angle	2
2	905-23014	Ratchet Jack - Heavy Duty	2
3	500-2-0687	Strut Tube Weldment	1
4	500-2-0657	Center Strut	2
5	700-2-0275	Tie Rod (Optional Rear Steer)	1
6	905-21194	3 x 8 Cylinder (Optional Rear Steer)	1
	905-21379	Seal Kit	1
7	903-05031	Pivot Link, RH	1
7	903-05030	Pivot Link, LH	1
8	900-06288	1-1/8 NC Jam Nut, RH	1
8	900-06310	1-1/8 NC Jam Nut, LH	1
9	500-2-0727	Wheel Strut (Optional Rear Steer)	2
10	500-2-0728	Strut Weldment (Optional Rear Steer)	2
11	500-2-0726	Cylinder Anchor (Optional Rear Steer)	1
12	900-01241	1/2 NC X 3-1/2 Hex Bolt, GR5	4
13	900-01415	3/4 NCx 3-1/2 HHCS	2
14	900-01437	3/4" NC x 8-1/2" Hex Bolt, GR5	4
15	900-03463	3/4" NC x 6" Eye Bolt	4
16	700-3-0143	Spindle	2
17	901-09215	Seal	1
18	901-01325	Bearing Cone (Inner)	1
19	901-01152	Bearing Cup (Inner)	1
20	905-09039	Wheel Bolt, 9/16-18 NFx 1-1/2" Long	8
21	905-09136	Hub	1
22	905-09134	Wheel Nut	8
23	901-01324	Bearing Cup (Outer)	1
24	901-01326	Bearing Cone (Outer)	1
25	905-09133	Washer	1
26	905-09132	Slotted Hex Nut, 7/8-14 UNF	1
27	905-09135	Dust Cap	1
28	905-09127	Rim (24x10.8)	4
29	905-09130	Tire (12.4- 24)	4
	905-09131	Inner Tube	4
30	500-2-0748	Pin Weldment	1
31	900-01221	1/2NCx1 Hex Bolt, GR5	1
32	901-01318	Split Bushing	2
33	200-3-0024	3/4 NC x 6 x 5.5 Long U-Bolt	2
	905-09128	Hub Assy. (Ref. 17-24)	1
	700-2-0167	Rim and Tire Assy. (LH)	2
	700-2-0168	Rim and Tire Assy. (RH)	2
	700-2-0165	Hub and Spindle	4
	500-2-0737	Strut with Hub (RH)	1
	500-2-0736	Strut with Hub (LH)	1





## MODEL FD 267 FOLDING DEFOLIATOR SCALPER COMPONENTS

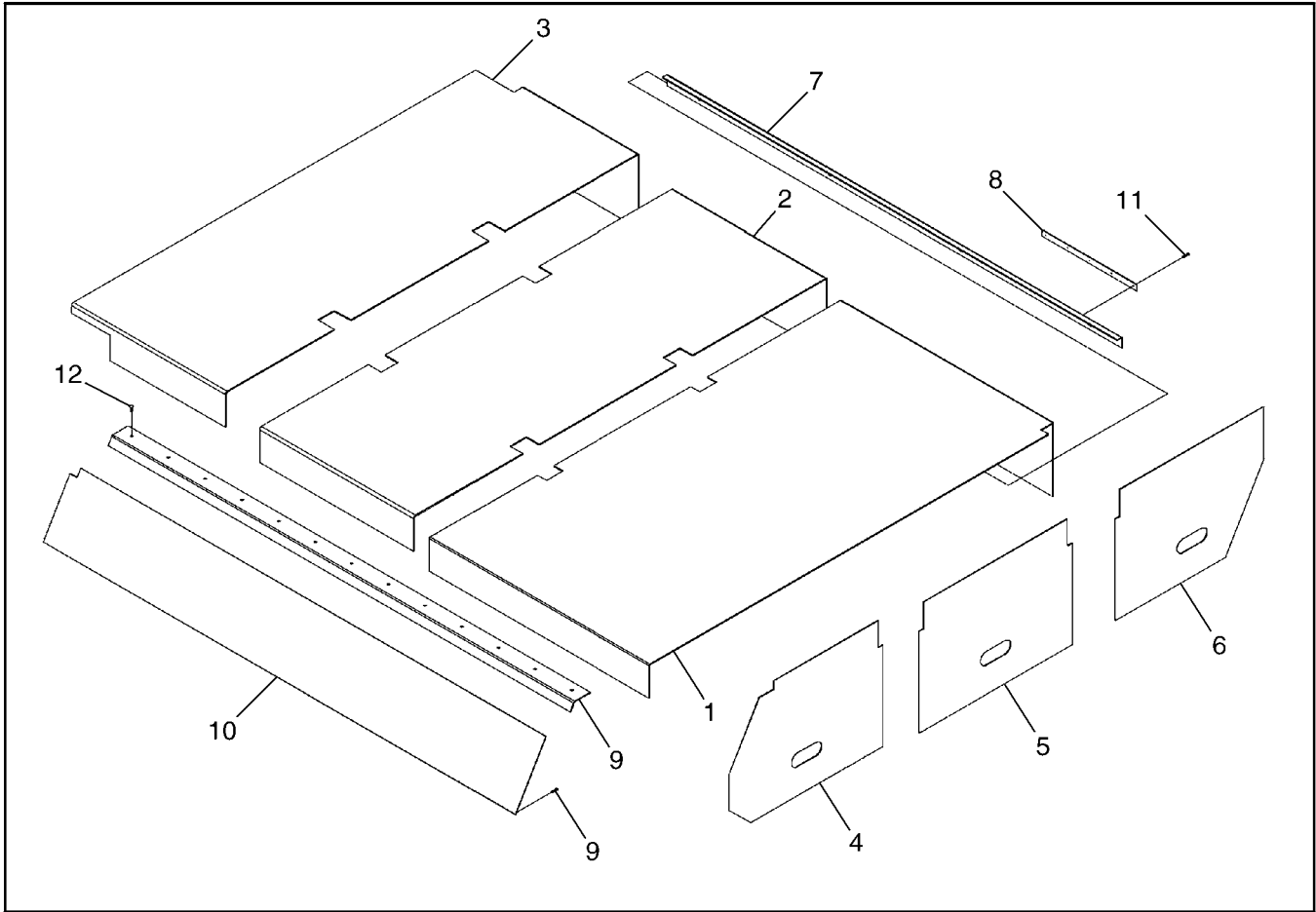
REF.	PART NO.	DESCRIPTION	QTY.
1	500-2-0684	1-1/4" Pin Weld	2
2	200-3-0877	Bushing	12
3	500-2-0691	Inner Scalper Unit Set-Back	1
4	500-2-0692	Outer Scalper Unit Set-Back	1
5	500-2-0693	Set-Back Spreader	1
	500-2-0738	Set-Back Rear Steer	1
6	500-2-0695	Inner Scalper Mount (with Lift Cylinder Bracket)	1
7	500-2-0696	Outer Scalper Mount (without Lift Cylinder Bracket)	1
8	500-2-0704	Scalper Shoe	6
9	500-2-0705	Scalper Tube	6
10	500-3-1556	Rear Spacer Tube	12
11	500-3-1557	Top Rear Adjusting Strap	6
12	500-3-1560	Bracket Plate	12
13	500-3-1561	Front Spreader Tube	12
14	500-2-0774	Pivot Bracket	6
15	500-3-1563	Rear Top Bracket Plate	12
16	901-09219	Scalper Hub	6
16	901-09220	Hub Repair Kit	A/R
17	500-3-1578	U-Bolt	4
18	500-3-1579	Scalper Unit Mounting Tube	1
19	500-3-1582	Scalper Disc	6
20	900-01055	1/4 NCx 3/4 Hex Bolt, GR5	36
21	900-01225	1/2" NC x 1-1/2" Hex Bolt, GR5	6
22	900-01247	1/2" NC x 4-1/2" Hex Bolt, GR5	16
23	900-01245	1/2" NCx 4 Hex Bolt, GR5	6
24	900-01251	1/2" NCx 5-1/2 Hex Bolt, GR5	30
25	900-01353	5/8" NC x 3 Hex Bolt, GR5	4
26	900-01431	3/4" NC x 6 Hex Bolt, GR5	6
27	900-01437	3/4" NC x 8-1/2" Hex Bolt, GR5	4
28	900-03463	3/4" NC x 6 Eye Bolt	4
29	900-06496	1/4" NC Top Lock Nut	36
30	905-21400	3-1/2" x 8" Cylinder	1
31	900-06145	5/8 NCSpirallock Flag Nut	A/R
	905-21401	Seal Kit	1
32	500-2-0762	Disc & Hub Assembly (Not Shown)	1
33	500-3-1940	Metal Disc Cap	1



### 500-2-0796 KIT/ROW, SCALPER DOWN PRESS COMPONENTS

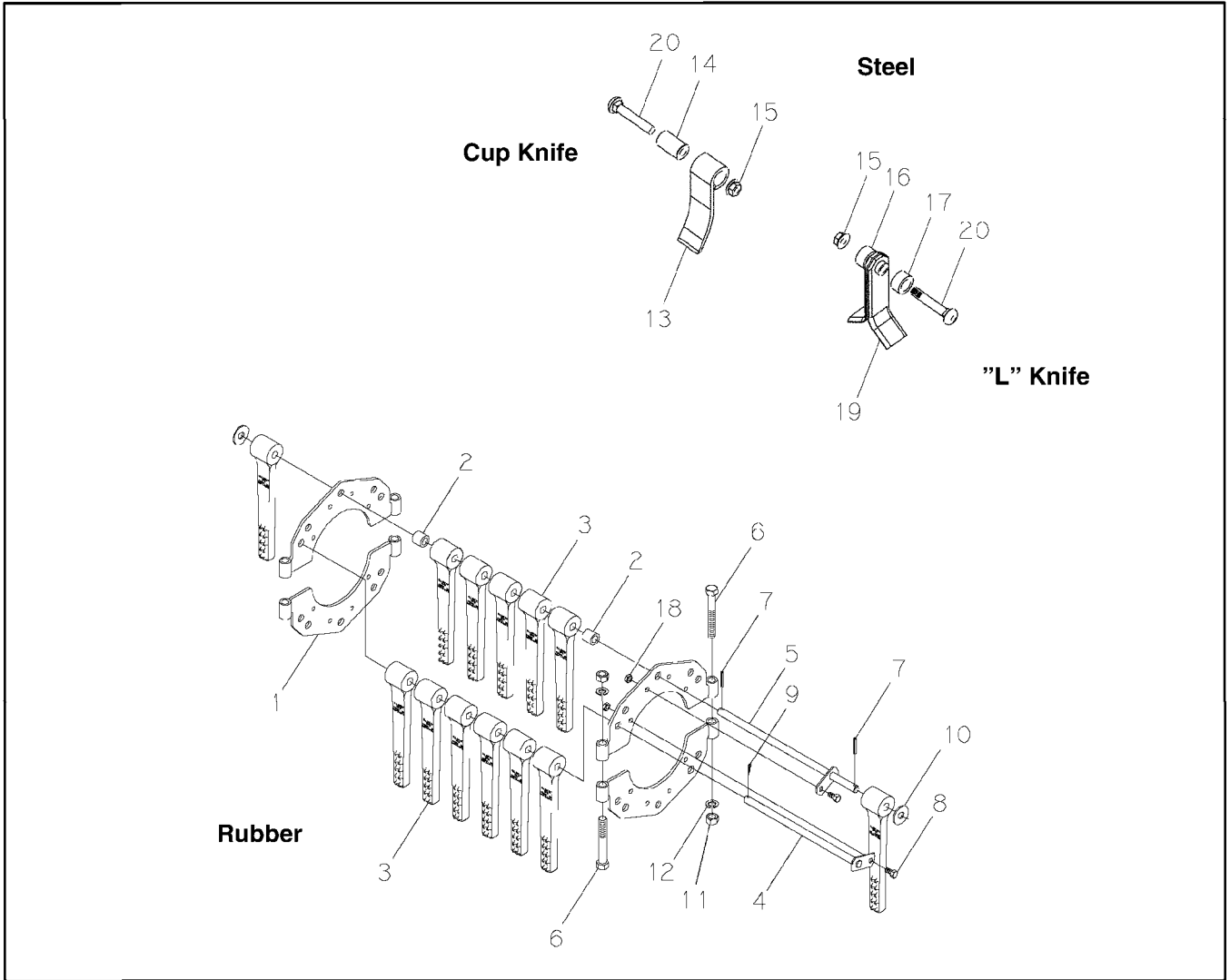
REF.	PART NO.	DESCRIPTION	QTY.
1	500-2-0072	Lift Rod Weld Scalper 143005	1
2	500-3-0157	Spring, Lift Arm, Light	1
3	500-3-0172	Collar, Retaining Spring 522002	1
4	500-3-1754	Plate, Formed, RH	1
5	500-3-1755	Plate, Formed, LH	1
6	500-3-1756	Plate, Spring	1
7	500-3-1757	Ear, Clamp	2
8	900-01223	1/2" NC x 1-1/4" Hex Bolt, GR5 ZP	6
9	900-01225	1/2" NC x 1-1/2" Hex Bolt, GR5 ZP	2
10	900-06143	1/2" NC Spirallock Flange Nut, GR8	7
11	900-06504	1/2" NC Top Lock, GRC ZP	1
12	900-11037	5/8" Flat Washer, ZP	2

## MODEL FD 267 FOLDING DEFOLIATOR COVER COMPONENTS



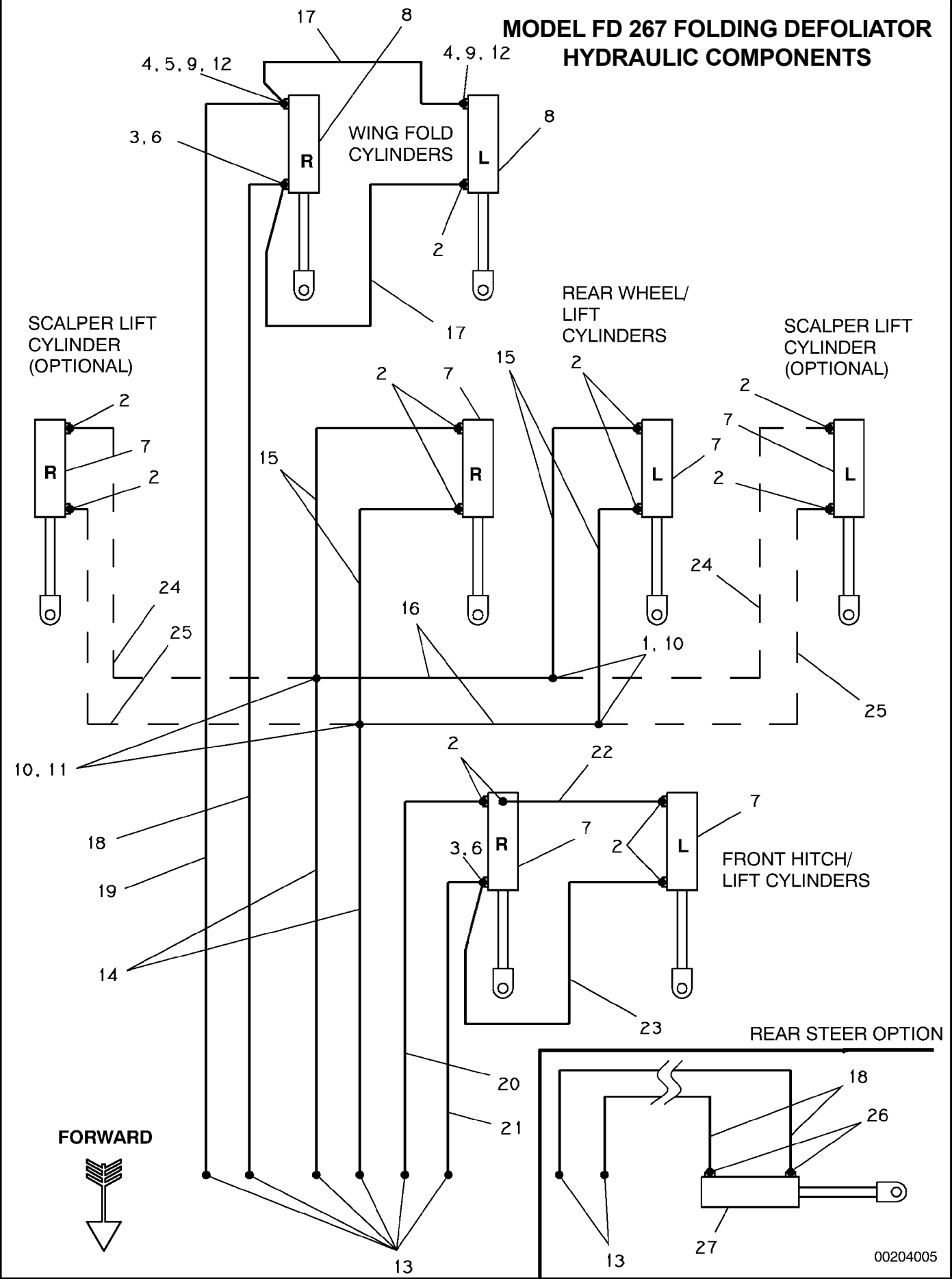
REF.	PART NO.	DESCRIPTION	QTY.
1	500-3-1537	Rubber Top (Outside)	1
2	500-3-1536	Rubber Top (Middle)	1
3	500-3-1535	Rubber Top (Inside)	1
4	500-3-1612	Plastic Liner (Front)	1
5	500-3-1613	Plastic Liner (Middle)	1
6	500-3-1514	Plastic Liner (Rear)	1
7	500-3-1467	Rear Top Tie	1
8	500-3-1533	Canvas Clamp Strip	A/R
9	500-3-1466	Top Cover Strip	1
10	500-3-1538	Front Plastic Cover (LH)	1
	500-3-1539	Front Plastic Cover (RH)	1
11	900-16964	1/4 x 1-1/2 Tek Screw	A/R
12	900-01695	3/8 NC x 1 Carr. Bolt	A/R

# MODEL FD 267 FOLDING DEFOLIATOR FLAIL COMPONENTS



REF.	PART NO.	DESCRIPTION	QTY.
1	500-2-0067	Flail Mounting Bracket	A/R
2	500-3-0151	1" Spacer	A/R
3	500-3-0316	Rubber Flail	A/R
4	500-2-0068	Rubber Flail Pin	A/R
5	500-2-0069	Rubber Flail Pin Extension	A/R
6	900-01363	5/8 NC x 4-1/2 Hex Bolt, GR5	A/R
7	900-29153	Roll Pin, 7/32 x 1-1/2	A/R
8	900-01105	3/8 NC x 3/4 Hex Bolt, GR5	A/R
9	900-23041	3/16 x 1 Cotter Pin	A/R
10	900-11131	Washer, Nylon 5/8 ID	A/R
11	900-06013	5/8 NC Hex Nut	A/R
12	900-11015	5/8 Lock Washer	A/R
13	505-3-0004	Steel Flail	A/R
	505-3-0972	Steel Flail (2001-2006 Production)	
14	505-3-0405	Bushing, Wear	A/R
15	900-06508	5/8 NC Top Lock Hex Nut	A/R
16	900-11037	5/8 Flat Washer	A/R
17	500-3-1736	Spacer	A/R
18	900-06500	3/8 Top Lock Nut	A/R
19	505-3-1735	Steel "L" Knife	A/R
20	900-03064	5/8-11 NC x 3-3/4 Carriage Bolt, GD8	A/R
21	505-3-1734	Weld-on Clip	A/R

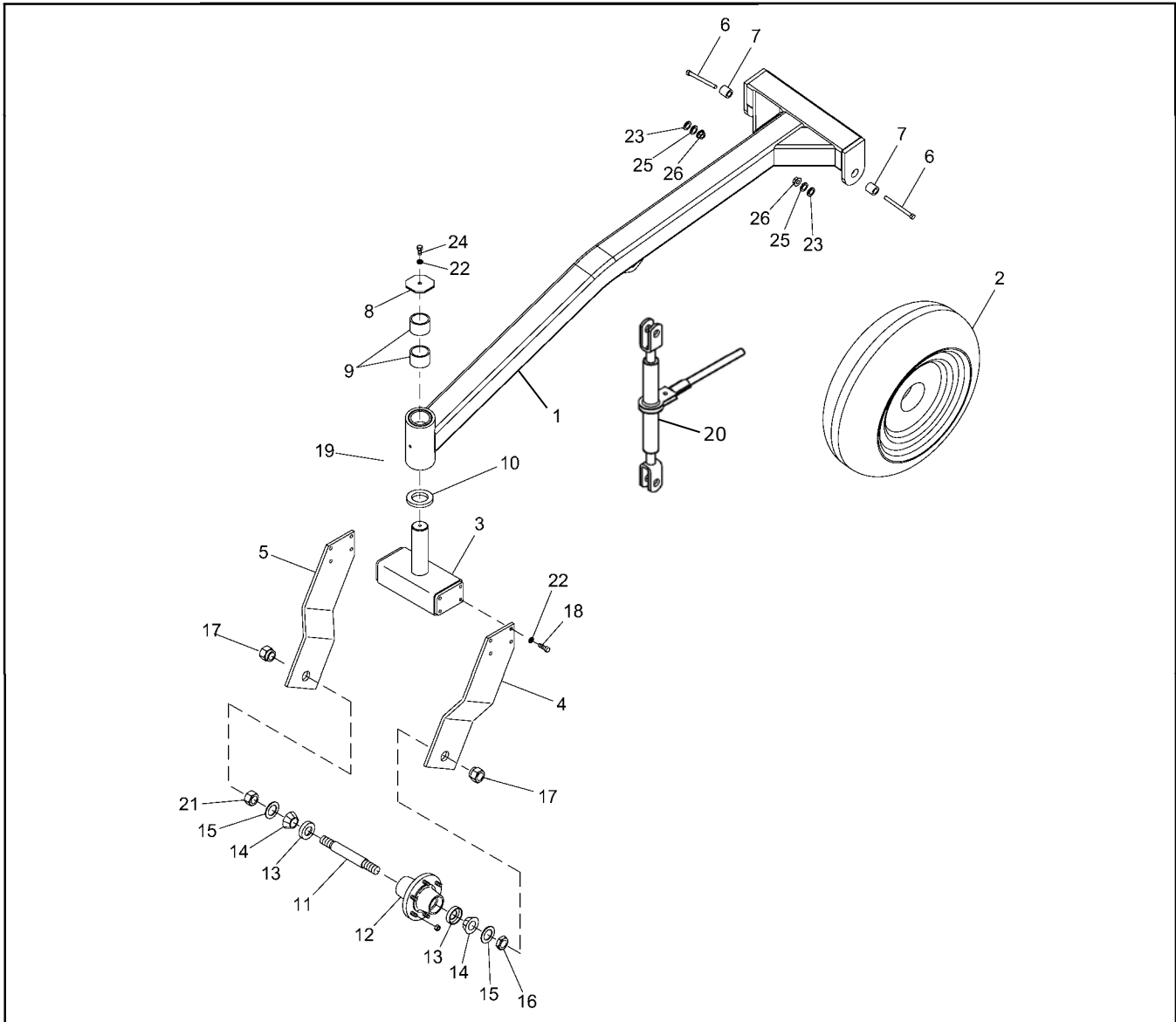
# MODEL FD 267 FOLDING DEFOLIATOR HYDRAULIC COMPONENTS



## MODEL FD 267 FOLDING DEFOLIATOR HYDRAULIC COMPONENTS

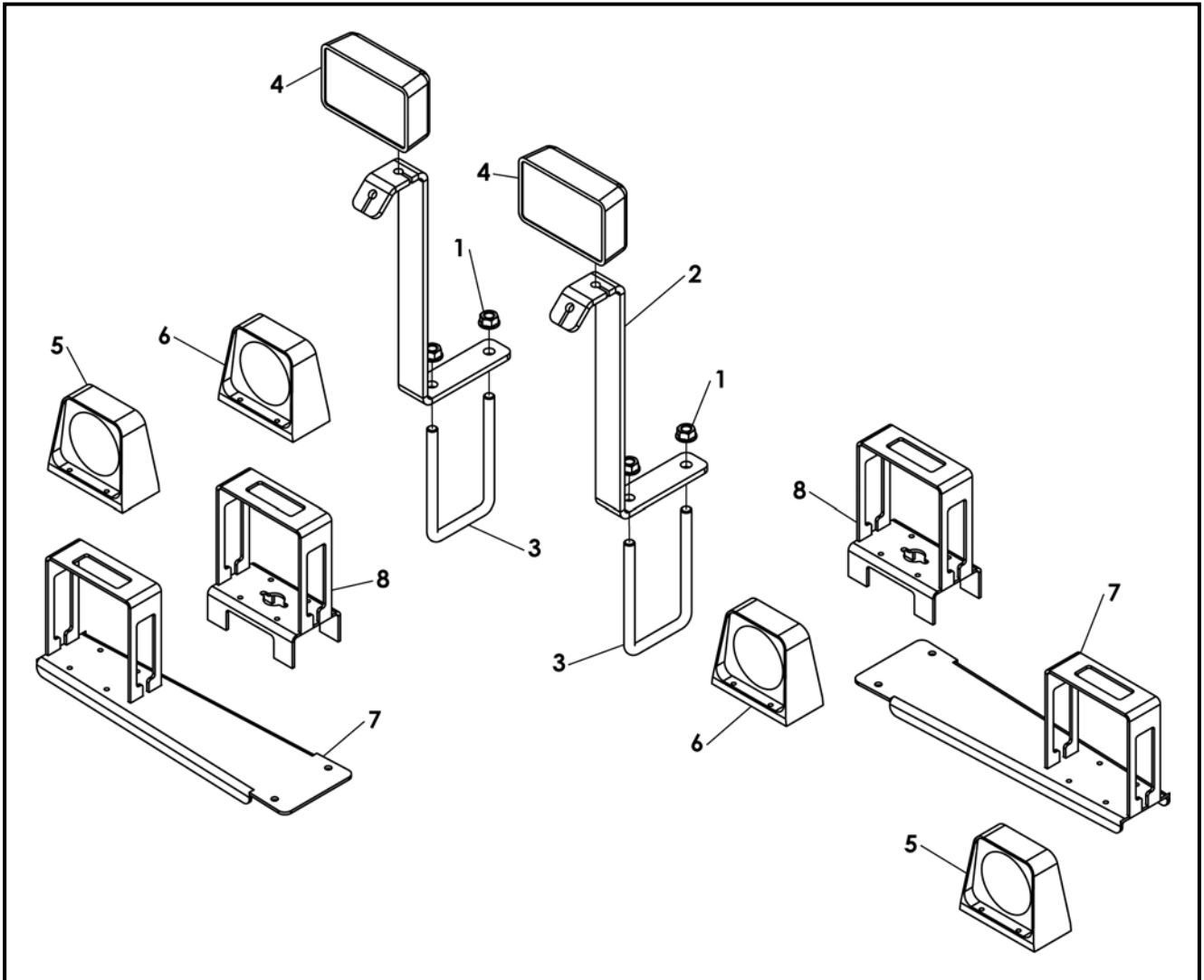
REF.	PART NO.	DESCRIPTION	QTY.
1	905-03112	Tee, 6 MJIC	2
2	905-03114	90 Deg. Adapter, 6 MJIC X 3/4-16 MORB	9/13
3	905-03115	Adapter, 6 MJICX3/4-16 MORB	2
4	905-03124	Adapter, 8 MORB X 3/4 FPT	2
5	905-03126	Tee, 6 MJIC X 6 FJIC X 6 MJIC	1
6	905-03127	Tee, 6 MJIC X 6 MJIC X 6 FJIC	2
7	905-21400	3-1/2 x 8 Cylinder with Depth Stop	4/6
	905-21401	Seal Kit, 3-1/2x8	A/R
	905-21419	Rod	
8	905-21395	4 x 24 Cylinder (Wing Lift)	2
	905-21409	Seal Kit, 4 x 24	2
9	905-03136	90 Deg Elbow, 6 MJIC X 6 MPT w/ Bevel	2
10	905-03140	Cap	4
11	905-03141	Cross, 6 MJIC	2
12	905-19112	3/8" Swivel Flow Restrictor 1/16	2
13	905-19126	Male Hydraulic Coupler	6
14	905-19133	3/8" Hose, 252" Long, 6 FJIC x 8 MORB	2
15	905-19134	3/8" Hose, 53-1/2" Long, 6 FJIC x 6 FJIC	4
16	905-19135	3/8" Hose, 58" Long, 6 FJIC x 6 FJIC	2
17	905-19136	3/8" Hose, 41-1/2" Long, 6 FJIC x 6 FJIC	2
18	905-19127	3/8" Hose, 300" Long, 6 FJIC x 8 MORB	1
19	905-19138	3/8" Hose, 324" Long, 6 FJIC x 8 MORB	1
20	905-19139	3/8" Hose, 150" Long, 6 FJIC x 8 MORB	1
21	905-19140	3/8" Hose, 138" Long, 6 FJIC x 8 MORB	1
22	905-19141	3/8" Hose, 50" Long, 6 FJIC x 6 FJIC	1
23	905-19142	3/8" Hose, 70" Long, 6 FJIC x 6 FJIC	1
24	905-19143	3/8" Hose, 130" Long, 6 FJIC x 6 FJIC	2
25	905-19121	3/8" Hose, 120" Long, 6 FJIC SVL x 8 MORB	2
26	905-03114	90 Deg Elbow, 6 MJIC x 3/4-16 MORB	2
27	905-21194	3 x 8 Cylinder (Optional Rear Steer)	1
	905-21379	Seal Kit, 3 x 8	1

## MODEL FD 267 FOLDING DEFOLIATOR STABILIZER WHEEL



REF	PART NO.	DESCRIPTION	QTY.	REF	PART NO.	DESCRIPTION	QTY.
1	500-2-0788	Weld, Stabilizer Wheel Arm	1	16	200-3-2726	Nut, short 1-1/4 NF	1
2	200-2-0988	Tire & Wheel Assembly	1	17	200-3-1847	1-1/4 NF Shoulder nut	2
3	200-2-0689	Caster pivot weldment		18	900-01225	1/2 NCx 1-1/2 Hex bolt GR5	8
4	200-3-2622	Side plate RH	1	19	905-15024	1/4-28 UNF Straight zerk	1
5	200-3-2621	Side plate LH		20	200-2-0705	Ratchet Jack w/Pipe, Painted	1
6	900-01407	3/4 x 3 Hex Bolt	2	21	900-06024	1-1/4 NF Hex nut	1
7	500-3-1751	Bushing Steel	2	22	900-11013	1/2 Lock Washer	9
8	200-3-1219	Retainer plate	1	23	900-11038	3/4 Flat Washer	2
9	200-3-1766	Bushing	2	24	900-01221	1/2 NCx 1 Hex bolt GR5	1
10	200-3-1233	Thrust bearing	1	25	900-11017	3/4 Lock Washer	2
11	200-3-1240	Spindle	1	26	900-06015	3/4 NC Hex Nut	3
12	905-09082	Hub with cups	1		500-1-0092	Stabilizer Wheels, (Pair)	
13	901-01148	Bearing cup	2		200-2-0928	Hub & Spindle Assembly (Ref. 11-16 & 21)	1
14	901-01149	Bearing cone	2				
15	901-09127	Seal	2				

## MODEL FD 267 FOLDING DEFOLIATOR LIGHT COMPONENTS

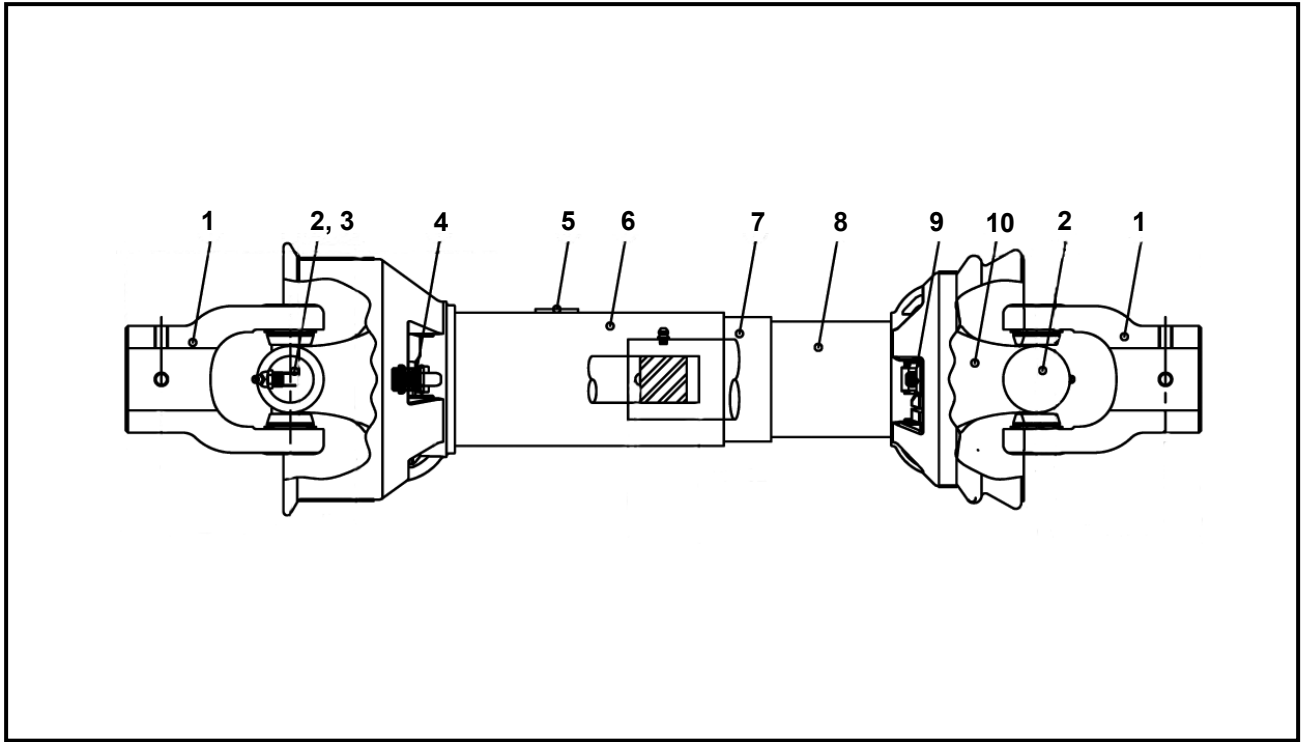


REF	PART NO.	DESCRIPTION	QTY.
1	900-06145	Nut, Flange, 5/8" NC GR8	4
2	500-3-1720	Bracket, Field Light	2
3	200-3-0017	U-Bolt 5/8 x 4 x 7.25" Long	2
4	500-3-1721	Light, Field	2
5	904-01154	Amber Lamp	2
6	904-01155	Red Lamp	2
7	500-2-0929	Amber Light Bracket	2
8	700-2-0151	Light Bracket (part of 500-2-0659)	2
9	500-1-0109	Field Light Bracket Kit (Ref 1, 2, 3)	1
10	500-3-2196	Wire Harness (Not Shown)	1



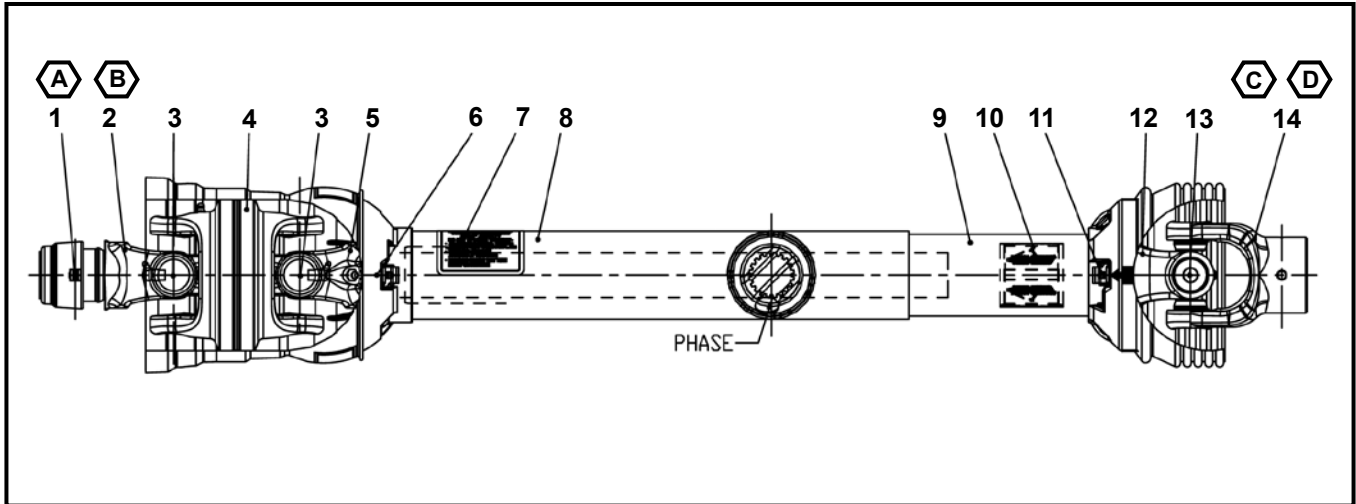


## MODEL FD 267 FOLDING DEFOLIATOR JUMP PTO SHAFT - WEASLER



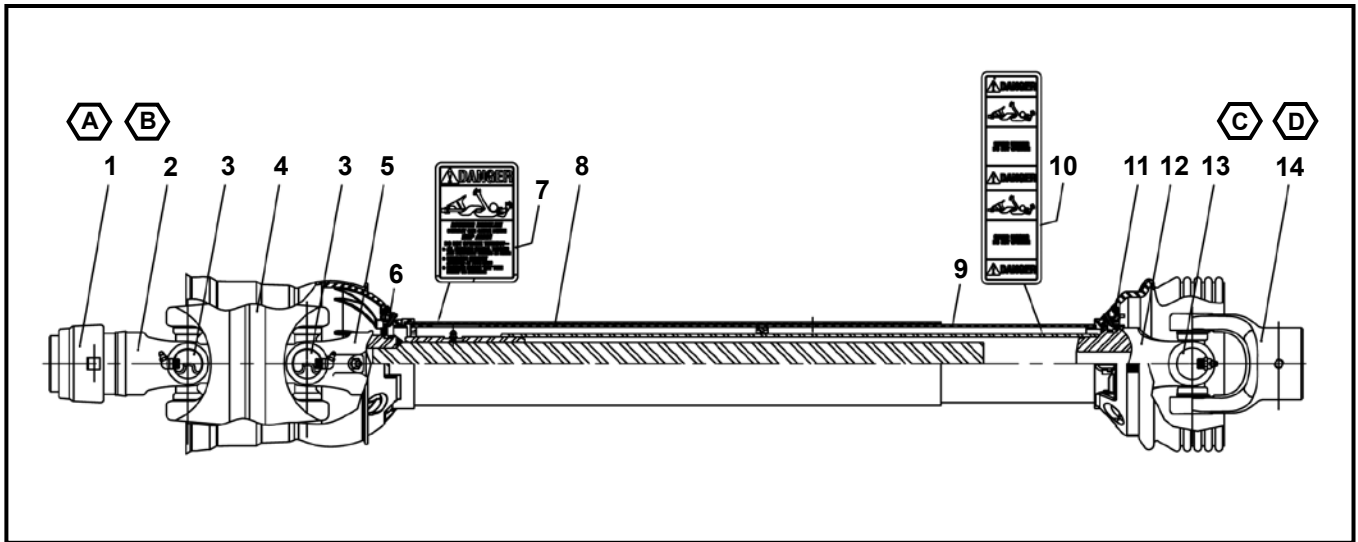
REF.	PART NO.	DESCRIPTION	QTY.
1	903-17639	Q.D. Yoke Assembly	2
2	903-17525	44R Cross & Bearing Kit	2
3	903-18208	Yoke & Shaft (1.31 Sq.)	1
4	903-18271	Guard Repair Kit (Not Shown)	1
5	903-17455	Safety Sign	1
6	903-18276	Outer Guard	2
7	903-18277	Inner Guard	1
8	903-18247	Safety Sign (Not Shown)	1
9	903-18248	Guard Repair Kit (Not Shown)	1
10	903-18209	Yoke, Tube & Slip Sleeve	1
	903-18207	Guard Set	
	903-18272	Joint & Shaft Half Assembly, with Guard	
	903-18273	Joint & Shaft Half Assembly	
	903-18274	Joint & Tube Half Assembly, with Guard	
	903-18275	Joint & Tube Half Assembly	
	903-18198	Jump PTO Shaft, Complete	1

**MODEL FD 267 FOLDING DEFOLIATOR  
1-3/8" PTO SHAFT - WEASLER  
CONSTANT VELOCITY**



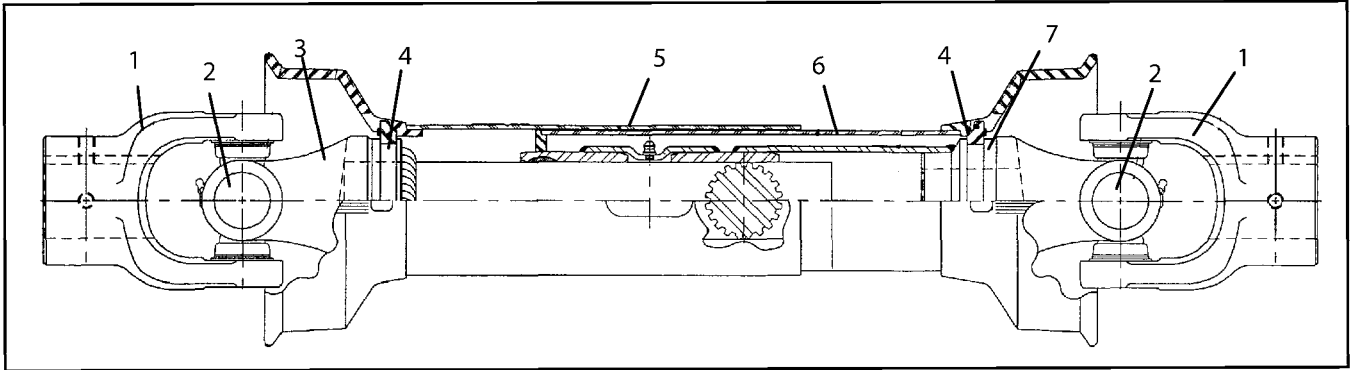
REF.	PART NO.	DESCRIPTION	QTY.
1	903-18240	Safety Slide Lock/Auto-Lok Repair Kit, 1-3/8"	1
2	903-18241	Safety Slide Lock Yoke Assembly, 1-3/8"	1
3	903-17712	CAT 5 80 E CV Cross & Bearing Kit	2
4	903-18242	CV Center Housing Assembly	1
5	903-18243	Yoke & Shaft (1.69-20), 1-3/8"	1
6	903-18244	Guard Repair Kit	1
7	903-17455	Safety Sign	1
8	903-18245	Outer Guard	1
9	903-18246	Inner Guard	1
10	903-18247	Safety Sign	1
11	903-18248	Guard Repair Kit	1
12	903-18249	Yoke, Tube & Slip Sleeve	1
13	903-18250	44E Cross & Bearing Kit	1
14	903-17639	Yoke	1
	903-18216	PTO Shaft, Complete (CV), 1-3/8"	1
A	903-18236	Joint & Shaft Half Assembly with Guard, 1-3/8"	
B	903-18237	Joint & Shaft Half Assembly, 1-3/8"	
C	903-18238	Joint & Tube Half Assembly with Guard, 1-3/8"	
D	903-18239	Joint & Tube Half Assembly, 1-3/8"	

**MODEL FD 267 FOLDING DEFOLIATOR  
1-3/4" PTO SHAFT - WEASLER  
CONSTANT VELOCITY**



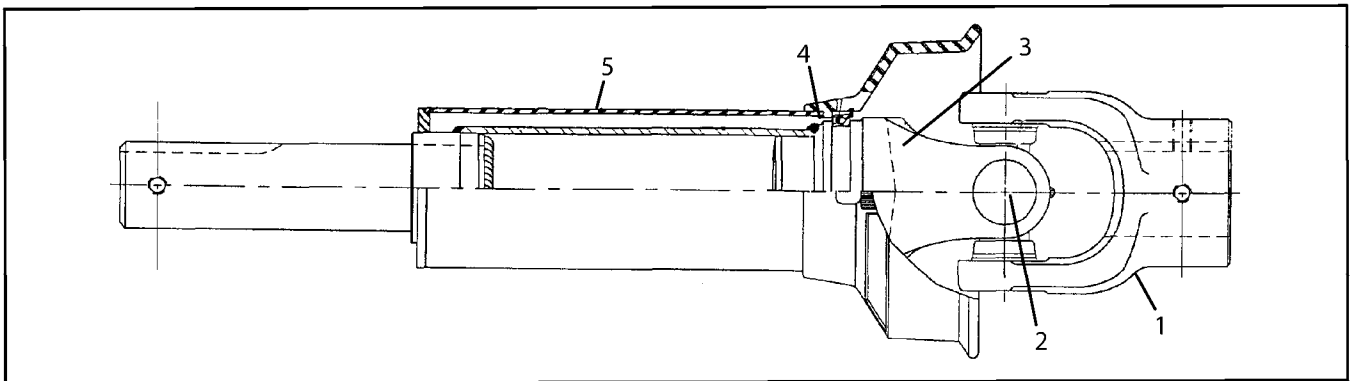
REF.	PART NO.	DESCRIPTION	QTY.
1	903-18255	Safety Slide Lock/Auto-Lok Repair Kit, 1-3/4"	1
2	903-18256	Safety Slide Lock Yoke Assembly, 1-3/4"	1
3	903-17712	CAT 5 80 E CV Cross & Bearing Kit	2
4	903-18242	CV Center Housing Assembly	1
5	903-18257	Yoke & Shaft (1.69-20 Spline), 1-3/4"	1
6	903-18244	Guard Repair Kit	1
7	903-17455	Safety Sign	1
8	903-18258	Outer Guard	1
9	903-18259	Inner Guard	1
10	903-18247	Safety Sign	1
11	903-18248	Guard Repair Kit	1
12	903-18260	Yoke, Tube & Slip Sleeve	1
13	903-18250	44E Cross & Bearing Kit	1
14	903-17639	Yoke	1
	903-18217	PTO Shaft, Complete (CV), 1-3/4"	1
A	903-18251	Joint & Shaft Half Assembly with Guard, 1-3/4"	
B	903-18252	Joint & Shaft Half Assembly, 1-3/4"	
C	903-18253	Joint & Tube Half Assembly with Guard, 1-3/4"	
D	903-18254	Joint & Tube Half Assembly, 1-3/4"	

## MODEL FD 267 FOLDING DEFOLIATOR WING DRIVE LINE



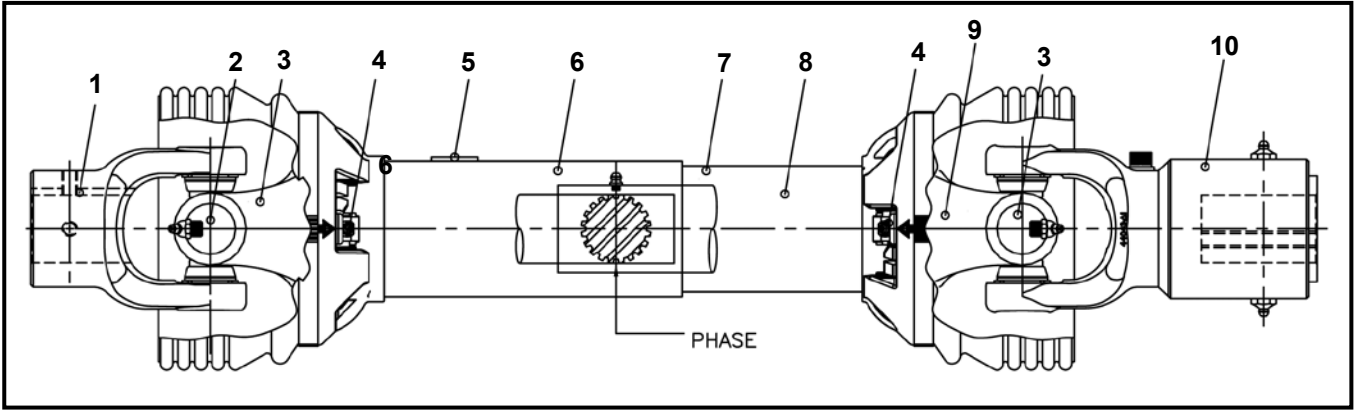
REF.	PART NO.	DESCRIPTION	QTY.
1	903-17639	Yoke	2
2	903-17525	44R Cross and Bearing Kit	2
3	903-18079	Yoke and Shaft	1
4	903-17851	Nylon Repair Kit	2
5	903-18080	Outer Guard	1
6	903-18081	Inner Guard	1
7	903-18082	Yoke, Tube, and Slip Sleeve	1
	903-18075	Joint and Shaft Half Assembly with Guard	1
	903-18076	Joint and Shaft Half Assembly	1
	903-18077	Joint and Tube Half Assembly with Guard	1
	903-18078	Joint and Tube Half Assembly	1
	903-18055	Shaft, Complete	

## MODEL FD 267 FOLDING DEFOLIATOR INTERMEDIATE SHAFT



REF.	PART NO.	DESCRIPTION	QTY.
1	903-17639	Yoke	1
2	903-17525	44R Cross and Bearing Kit	1
3	903-18085	Yoke, Tube, and Stub Shaft	1
4	903-17851	Nylon Repair Kit	1
5	903-18084	Inner Guard	1
	903-18083	Joint and Tube half Asm.	1
	903-18052	Assy. Complete	

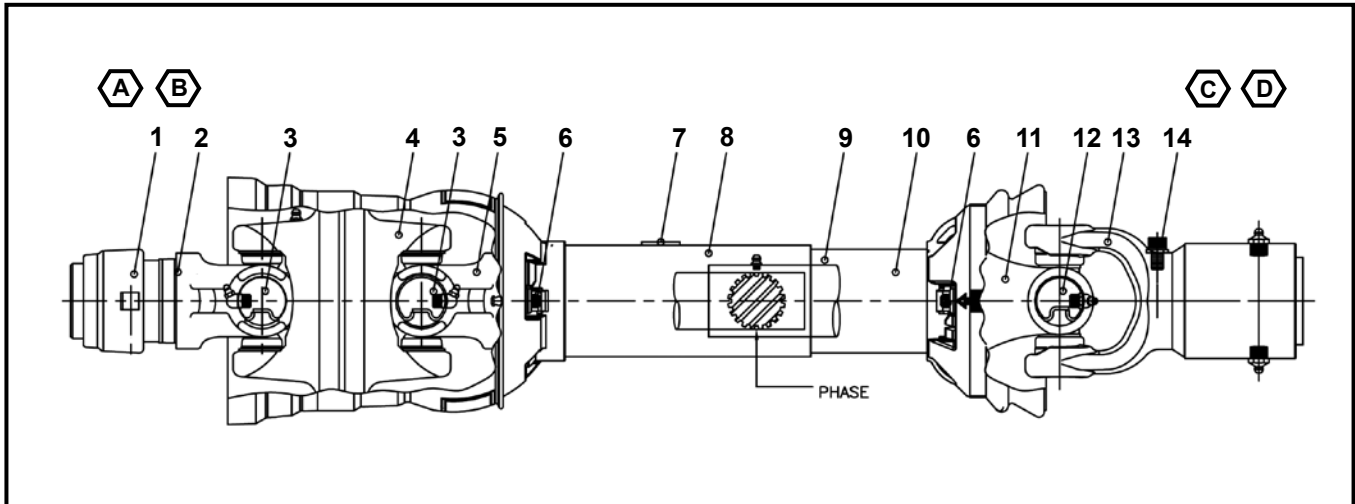
## MODEL FD 267 FOLDING DEFOLIATOR OVER RUN DRIVE SHAFT



REF.	PART NO.	DESCRIPTION	QTY.
1	903-17639	Yoke	1
2	903-18250	44E Cross and Bearing Kit	2
3	903-18266	Yoke and Shaft (1.69-20 Spline)	1
4	903-18248	Guard Repair Kit (Not Shown)	2
5	903-17455	Safety Sign	1
6	903-18267	Outer Guard	1
7	903-18268	Inner Guard	1
8	903-18247	Safety Sign (Not Shown)	1
9	903-18269	Yoke, Tube, and Slip Sleeve	1
10	903-18270	Over Running Clutch Assembly	1
	903-18261	Guard Set	1
	903-18262	Joint and Shaft Half Assembly with Guard	1
	903-18263	Joint and Shaft Half Assembly	1
	903-18264	Joint and Tube Half Assembly with Guard	1
	903-18265	Joint and Tube Half Assembly	1
	903-18215	Shaft, Complete	1

## NOTES

**MODEL FD 267 FOLDING DEFOLIATOR  
PTO SHAFT - WEASLER CONSTANT  
VELOCITY (2001-2006 PRODUCTION)**



REF.	PART NO.	DESCRIPTION	QTY.
1	903-18106	Safety Slide Lock/Auto-Lok Repair Kit, 1-3/8"	1
	903-17772	Safety Slide Lock/Auto-Lok Repair Kit, 1-3/4"	
2	903-17733	Safety Slide Lock Yoke Assembly, 1-3/8"	1
	903-18121	Safety Slide Lock Yoke Assembly, 1-3/4"	
3	903-17737	CAT 6 80 E CV Cross & Bearing Kit	2
4	903-18203	CV Center Housing Assembly	1
5	903-18204	Yoke & Shaft (1.69-20 Spline)	1
6	903-18248	Guard Repair Kit	1
7	903-17455	Safety Sign	1
8	903-18297	Outer Guard	1
9	903-18298	Inner Guard	1
10	903-17456	Safety Sign (Not Shown)	1
11	903-18205	Yoke, Tube & Slip Sleeve	1
12	903-17239	55E Cross & Bearing Kit	1
13	903-18206	Overrunning Clutch Assembly	1
14	903-18188	Overrunning Clutch Repair Kit	1
	903-18196	PTO Shaft, Complete (CV), 1-3/8"	1
	903-18197	PTO Shaft, Complete (CV), 1-3/4"	
	903-18199	Guard Set	1
A	903-18200	Joint & Shaft Half Assembly with Guard, 1-3/8"	
	903-18201	Joint & Shaft Half Assembly with Guard, 1-3/4"	
B	903-18299	Joint & Shaft Half Assembly, 1-3/8"	
	903-18300	Joint & Shaft Half Assembly, 1-3/4"	
C	903-18202	Joint & Tube Half Assembly with Guard	
D	903-18301	Joint & Tube Half Assembly	

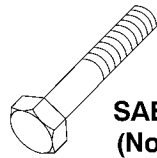
# BOLT TORQUE CHART

## SAE Series Torque Chart

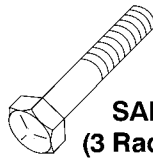
Always tighten hardware to these values unless a different torque value or tightening procedure is listed for a specific application. Fasteners must always be replaced with the same grade as specified in the manual parts list.

Make sure fastener threads are clean and you properly start thread engagement.

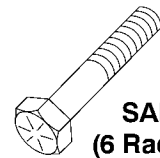
### SAE Bolt Head Identification



**SAE Grade 2  
(No Dashes)**



**SAE Grade 5  
(3 Radial Dashes)**



**SAE Grade 8  
(6 Radial Dashes)**

Bolt Diameter "A"	Wrench Size	MARKING ON HEAD					
		SAE2		SAE5		SAE8	
		Lbs.-Ft.	(N-m)	Lbs.-Ft.	(N-m)	Lbs.-Ft.	(N-m)
1/4"	7/16"	6	(8)	11	(15)	14	(19)
5/16"	1/2"	13	(18)	21	(28)	25	(34)
3/8"	9/16"	23	(31)	38	(52)	55	(75)
7/16"	5/8"	37	(50)	55	(75)	80	(110)
1/2"	3/4"	57	(77)	65	(115)	120	(165)
9/16"	13/16"	82	(111)	125	(170)	180	(245)
5/8"	15/16"	111	(150)	175	(240)	230	(310)
3/4"	1-1/8"	200	(270)	300	(410)	440	(600)
7/8"	1-5/16"	280	(380)	450	(610)	720	(975)
1"	1-1/2"	350	(475)	680	(925)	1035	(1400)
1-1/8"	1-11/16"	450	(610)	885	(1200)	<p>Bolt Diameter</p>	
1-1/4"	1-7/8"	600	(815)	1255	(1700)		
1-3/8"	2-1/16"	675	(915)	1620	(2200)		
1-1/2"	2-1/4"	920	(1250)	2200	(2900)		

## Metric Series Torque Chart

Use only metric tools on metric hardware.

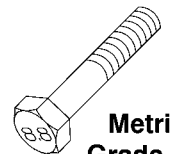
Always tighten hardware to these values unless a different torque value or tightening procedure is listed for a specific application.

Fasteners must always be replaced with the same grade.

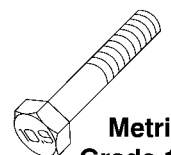
Make sure fastener threads are clean and you properly start thread engagement.

Bolt Diameter "A"	Wrench Size	MARKING ON HEAD			
		8.8		10.9	
		N-m	(Lbs.-Ft.)	N-m	(Lbs.-Ft.)
5 mm	8 mm	6	(4.5)	9	(6.5)
6 mm	10 mm	10	(7.5)	15	(11)
8 mm	13 mm	25	(18)	35	(26)
10 mm	16 mm	50	(37)	75	(55)
12 mm	18 mm	85	(63)	130	(97)
14 mm	21 mm	110	(80)	150	(110)
16 mm	24 mm	215	(159)	315	(232)
20 mm	30 mm	435	(321)	620	(457)
24 mm	36 mm	750	(553)	1070	(789)
30 mm	46 mm	1495	(1103)	2130	(1571)

### Metric Bolt Head Identification

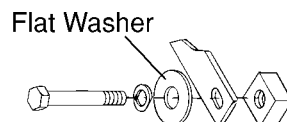
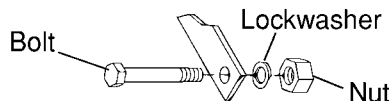


**Metric Grade 8.8**



**Metric Grade 10.9**

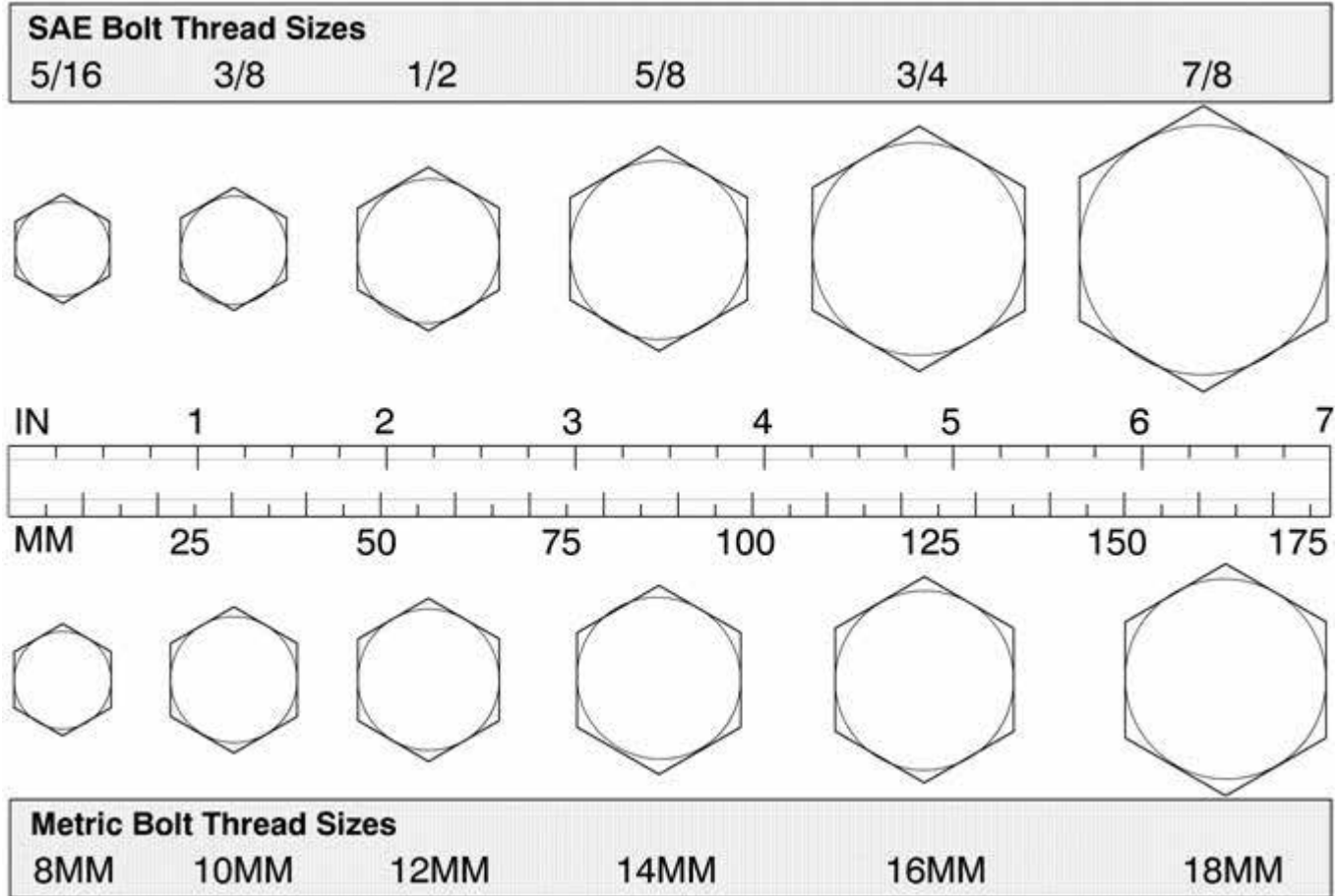
## Typical Washer Installations



8/9/00

# BOLT SIZE CHART

NOTE: Chart shows bolt thread sizes and corresponding head (wrench) sizes for standard SAE and Metric Bolts.



## ABBREVIATIONS

AG .....	Agriculture	NC .....	National Coarse
ATF .....	Automatic Transmission Fluid	NF .....	National Fine
BSPP .....	British Standard Pipe Parallel	NPSM .....	National Pipe Straight Mechanical
BSPTM .....	British Standard Pipe Tapered Male	NPT .....	National Pipe Tapered
CV .....	Constant Velocity	NPT SWF .....	National Pipe Tapered Swivel Female
CCW .....	Counter-Clockwise	ORBM .....	O-Ring Boss - Male
CW .....	Clockwise	P .....	Pitch
F .....	Female	PBY .....	Power Beyond
GA .....	Gauge	psi .....	Pounds per Square Inch
GR (5, etc.) .....	Grade (5, etc.)	PTO .....	Power Take Off
HHCS .....	Hex Head Cap Screw	QD .....	Quick Disconnect
HT .....	Heat Treated	RH .....	Right Hand
JIC .....	Joint Industry Council 37° Degree Flare	ROPS .....	Roll Over Protective Structure
LH .....	Left Hand	RPM .....	Revolutions Per Minute
LT .....	Left	RT .....	Right
m .....	Meter	SAE .....	Society of Automotive Engineers
mm .....	Millimeter	UNC .....	Unified Coarse
M .....	Male	UNF .....	Unified Fine
MPa .....	Mega Pascal	UNS .....	Unified Special
N .....	Newton		



---

# NOTES

# NUMERICAL INDEX

PART NO.	PAGE	PART NO.	PAGE	PART NO.	PAGE	PART NO.	PAGE
100-3-3333	33	500-2-0692	39	500-3-1538	40	505-3-0831	33
100-3-3333	35	500-2-0693	39	500-3-1539	40	505-3-0868	35
100-3-3957	33	500-2-0695	39	500-3-1540	35	505-3-0972	41
100-3-3958	33	500-2-0696	39	500-3-1541	35	505-3-1734	41
120-3-0472	33	500-2-0699	35	500-3-1556	39	505-3-1735	41
200-2-0689	44	500-2-0704	39	500-3-1557	39	700-2-0151	45
200-2-0705	44	500-2-0705	39	500-3-1560	39	700-2-0159	33
200-2-0928	44	500-2-0726	37	500-3-1561	39	700-2-0165	37
200-2-0988	44	500-2-0727	37	500-3-1563	39	700-2-0167	37
200-3-0017	45	500-2-0728	37	500-3-1578	39	700-2-0168	37
200-3-0024	37	500-2-0736	37	500-3-1579	39	700-2-0275	37
200-3-0877	39	500-2-0737	37	500-3-1582	39	700-3-0143	37
200-3-1219	44	500-2-0738	39	500-3-1612	40	700-3-0444	33
200-3-1233	44	500-2-0748	33	500-3-1613	40	700-3-1220	33
200-3-1240	44	500-2-0748	37	500-3-1628	35	900-01055	39
200-3-1766	44	500-2-0749	33	500-3-1629	35	900-01105	41
200-3-1847	44	500-2-0750	33	500-3-1631	33	900-01195	33
200-3-2621	44	500-2-0752	35	500-3-1632	35	900-01221	33
200-3-2622	44	500-2-0753	35	500-3-1636	35	900-01221	35
200-3-2726	44	500-2-0754	35	500-3-1684	33	900-01221	37
500-1-0092	44	500-2-0755	35	500-3-1685	35	900-01221	44
500-1-0100	33	500-2-0756	35	500-3-1696	33	900-01223	39
500-1-0109	45	500-2-0757	35	500-3-1718	33	900-01225	33
500-2-0067	41	500-2-0758	35	500-3-1720	33	900-01225	39
500-2-0068	41	500-2-0759	35	500-3-1720	33	900-01225	39
500-2-0069	41	500-2-0762	39	500-3-1720	45	900-01225	44
500-2-0072	39	500-2-0774	39	500-3-1721	33	900-01233	33
500-2-0532	33	500-2-0784	35	500-3-1721	45	900-01241	37
500-2-0657	37	500-2-0785	35	500-3-1724	33	900-01245	39
500-2-0658	33	500-2-0788	44	500-3-1725	33	900-01247	39
500-2-0659	33	500-2-0929	45	500-3-1736	41	900-01251	39
500-2-0661	33	500-2-0954	33	500-3-1751	44	900-01353	39
500-2-0662	33	500-3-0151	41	500-3-1754	39	900-01363	41
500-2-0663	33	500-3-0157	39	500-3-1755	39	900-01399	35
500-2-0664	33	500-3-0172	39	500-3-1756	39	900-01407	44
500-2-0670	35	500-3-0316	41	500-3-1757	39	900-01415	37
500-2-0671	35	500-3-1061	35	500-3-1940	39	900-01431	39
500-2-0672	35	500-3-1461	35	500-3-2164	33	900-01437	37
500-2-0673	35	500-3-1462	35	500-3-2165	33	900-01437	39
500-2-0674	35	500-3-1463	35	500-3-2196	35	900-01515	33
500-2-0682	33	500-3-1466	40	500-3-2196	45	900-01519	33
500-2-0684	33	500-3-1467	40	500-3-2211	33	900-01694	33
500-2-0684	39	500-3-1510	33	500-3-2237	33	900-01695	40
500-2-0685	33	500-3-1514	40	500-3-2238	33	900-01751	35
500-2-0686	37	500-3-1533	40	505-3-0004	41	900-01784	35
500-2-0687	37	500-3-1535	40	505-3-0405	41	900-03033	46
500-2-0690	35	500-3-1536	40	505-3-0713	33	900-03052	35
500-2-0691	39	500-3-1537	40	505-3-0739	35	900-03064	41

## NUMERICAL INDEX *(Continued)*

PART NO.	PAGE	PART NO.	PAGE	PART NO.	PAGE	PART NO.	PAGE
900-03463	37	901-01272	35	903-17639	49	903-18236	48
900-03463	39	901-01309	35	903-17639	50	903-18237	48
900-03467	35	901-01310	35	903-17639	50	903-18238	48
900-06013	41	901-01311	35	903-17639	51	903-18239	48
900-06015	44	901-01312	35	903-17712	48	903-18240	48
900-06024	44	901-01313	35	903-17712	49	903-18241	48
900-06143	39	901-01314	35	903-17733	52	903-18242	48
900-06145	39	901-01315	35	903-17737	52	903-18242	49
900-06145	45	901-01318	33	903-17772	52	903-18243	48
900-06288	37	901-01318	37	903-17851	50	903-18244	48
900-06310	37	901-01324	37	903-17851	50	903-18244	49
900-06496	39	901-01325	37	903-18007	33	903-18245	48
900-06500	41	901-01326	37	903-18052	33	903-18246	48
900-06504	39	901-01328	46	903-18052	50	903-18247	47
900-06508	41	901-09125	46	903-18055	33	903-18247	48
900-06630	35	901-09127	44	903-18055	50	903-18247	49
900-11013	44	901-09215	37	903-18075	50	903-18247	51
900-11015	41	901-09219	39	903-18076	50	903-18248	47
900-11017	44	901-09220	39	903-18077	50	903-18248	48
900-11037	39	903-01433	35	903-18078	50	903-18248	49
900-11037	41	903-01434	35	903-18079	50	903-18248	51
900-11038	44	903-05030	37	903-18080	50	903-18248	52
900-11072	35	903-05031	37	903-18081	50	903-18249	48
900-11131	41	903-08362	35	903-18082	50	903-18250	48
900-16964	40	903-08362	35	903-18083	50	903-18250	49
900-17046	33	903-08362	35	903-18084	50	903-18250	51
900-21489	33	903-08363	35	903-18085	50	903-18251	49
900-23034	35	903-08420	35	903-18106	52	903-18252	49
900-23041	41	903-08421	35	903-18121	52	903-18253	49
900-23045	33	903-08421	35	903-18188	52	903-18254	49
900-29153	41	903-15525	46	903-18196	52	903-18255	49
900-31068	33	903-15526	46	903-18197	52	903-18256	49
900-31069	33	903-15560	33	903-18198	33	903-18257	49
900-39030	46	903-15560	46	903-18198	47	903-18258	49
900-42051	33	903-15561	46	903-18199	52	903-18259	49
900-42054	33	903-15562	46	903-18200	52	903-18260	49
900-42055	33	903-17239	51	903-18201	52	903-18261	51
901-01133	33	903-17455	47	903-18202	52	903-18262	51
901-01148	44	903-17455	48	903-18203	52	903-18263	51
901-01149	44	903-17455	49	903-18204	52	903-18264	51
901-01150	46	903-17455	51	903-18205	52	903-18265	51
901-01151	46	903-17455	52	903-18206	52	903-18266	51
901-01152	37	903-17456	52	903-18207	47	903-18267	51
901-01152	46	903-17525	47	903-18208	47	903-18268	51
901-01153	46	903-17525	50	903-18209	47	903-18269	51
901-01185	33	903-17525	50	903-18215	51	903-18270	51
901-01186	35	903-17639	47	903-18216	48	903-18271	47
901-01272	33	903-17639	48	903-18217	49	903-18272	47

## NUMERICAL INDEX *(Continued)*

<b>PART NO.</b>	<b>PAGE</b>	<b>PART NO.</b>	<b>PAGE</b>
903-18273	47	905-19135	43
903-18274	47	905-19136	43
903-18275	47	905-19138	43
903-18276	47	905-19139	43
903-18277	47	905-19140	43
903-18297	52	905-19141	43
903-18298	52	905-19142	43
903-18299	52	905-19143	43
903-18300	52	905-21194	37
903-18301	52	905-21194	43
904-01132	33	905-21379	37
904-01154	45	905-21379	43
904-01155	45	905-21395	33
905-01238	33	905-21395	43
905-03078	46	905-21400	33
905-03080	46	905-21400	39
905-03112	43	905-21400	43
905-03114	43	905-21401	33
905-03114	43	905-21401	39
905-03115	43	905-21401	43
905-03124	43	905-21409	33
905-03126	43	905-21409	43
905-03127	43	905-21419	43
905-03136	43	905-23014	37
905-03140	43		
905-03141	43		
905-04189	33		
905-07113	33		
905-09039	37		
905-09082	44		
905-09127	37		
905-09128	37		
905-09130	37		
905-09131	37		
905-09132	37		
905-09133	37		
905-09134	37		
905-09135	37		
905-09136	37		
905-15024	33		
905-15024	44		
905-15359	46		
905-19112	43		
905-19121	43		
905-19126	43		
905-19127	43		
905-19133	43		
905-19134	43		

# INDEX

## ADJUSTMENTS

- Belt Tension, 27
- Front to Rear Leveling, 21
- Scalper, 23

## ASSEMBLY

- Delivery Checklist (Dealer's Responsibility), 6
- Pre-Delivery Checklist (Dealer's Responsibility), 6

## CHECK LISTS

- Delivery Check List(Dealer's Responsibility), 6
- Pre-Delivery Check List(Dealer's Responsibility), 6
- Pre-Operation Check List(Owner's Responsibility), 14

## GENERAL

- Abbreviations, 54
- Bolt Size Chart, 54
- Bolt Torque Chart, 53
- Check Lists, 6
- General Information, 5
- Introduction, 2
- Product Warranty, 60
- Replacement Parts Warranty, 61
- Table of Contents, 1

## OPERATION, 12

- Attaching Defoliator to Tractor, 16
  - Verification of Control Movements, 17
- Breaking-in, 14
- Cylinder Locks, 18
- Disconnecting Defoliator from Tractor, 18
- Equipment Matching, 15
  - CV Driveline Turning Limits, 15
  - Drawbar, 15
  - Drawbar Dimensions, 15
  - Electrical System, 16
  - Hydraulic System, 15
  - PTO, 15
  - Tractor Ballast, 16
  - Tractor Hydraulic System Requirements, 15
- Field Operation, 21
  - Entering the Field, 22
  - Field Performance, 22
  - Front to Rear Leveling, 21
  - Lowering Wings to Operating Position, 20
  - Raising Wings to Transport Position, 19
  - Rear Steering (Optional), 22
  - Scalper Attachments (Optional), 23
  - Starting Defoliator, 22
  - Stopping Defoliator, 22
  - Unfolding of Defoliator, 20

## OPERATION (Continued)

- Mounting & Dismounting Tractor, 16
- Pre-Operation Check List (Owner's Responsibility), 13
- Principal Components, 13
- Storage, 24
- Transporting the Defoliator, 23
- Trouble Shooting, 29
- Unfolding of Defoliator, 20

## OPTIONAL EQUIPMENT

- Rear Steering, 22
- Scalper Attachment, 23

## OWNER SERVICE

- Blocking Method, 25
- Lubrication, 26
  - Gearbox Oil, 26
  - Grease Intervals, 27
  - Greasing, 26
  - Lubrication Points, 26
  - Sealed Bearing Information, 26
- Maintenance, 27
  - Drive Belts, 27
    - Replacing, 28
    - Tension Adjustment, 27
  - Flail Replacement, 28
    - Cup Knife, 28
    - L-Knife, 28
    - Rubber Flail, 28

## PARTS INDEX, 31

## SAFETY

- Blocking Method for Service, 25
- Check Lists
  - Delivery (Dealer's Responsibility), 6
  - Pre-Delivery (Dealer's Responsibility), 6
  - Pre-Operation Check List (Owner's Responsibility), 13
- Operator Sign-off Record, 11
- Pre-Operation Check List, 14
- Safety & Instructional Decals, 7–8
- Safety-Alert Symbol (Explanation), 2
- Safety Rules, 2

## TROUBLE SHOOTING, 29

# WARRANTY

Please Enter Information Below and Save For Future Reference.

Date Purchased: \_\_\_\_\_ From (Dealer): \_\_\_\_\_

Model Number: \_\_\_\_\_ Serial Number: \_\_\_\_\_

ALLOWAY STANDARD, d/b/a ALLOWAY, warrants this product to be free from defect in material and workmanship for TWELVE (12) MONTHS COMMENCING ON THE DATE OF DELIVERY OF THE PRODUCT TO THE ORIGINAL PURCHASER.

Under no circumstances will this Warranty apply in the event that the product, in the good faith opinion of ALLOWAY, has been subjected to improper operation, improper maintenance, misuse, or an accident. This Warranty does not apply in the event that the product has been materially modified or repaired by someone other than ALLOWAY, a ALLOWAY authorized dealer or distributor, and/or a ALLOWAY authorized service center; This Warranty does not cover normal wear or tear, or normal maintenance items. This Warranty also does not cover repairs made with parts other than those obtainable through ALLOWAY.

This Warranty is extended solely to the original purchaser of the product. Should the original purchaser sell or otherwise transfer this product to a third party, this Warranty does not transfer to the third party purchaser in any way. There are no third party beneficiaries of this Warranty.

ALLOWAY makes no warranty, express or implied, with respect to tires or other parts or accessories not manufactured by ALLOWAY. Their respective manufacturers, if any, provide warranties for these items, separately. ALLOWAY'S' obligation under this Warranty is limited to, at ALLOWAY'S' option, the repair or replacement, free of charge, of the product if ALLOWAY, in its sole discretion, deems it to be defective or in noncompliance with this Warranty. The product must be returned to ALLOWAY with proof of purchase within thirty (30) days after such defect or noncompliance is discovered or should have been discovered, routed through the dealer and distributor from whom the purchase was made, transportation charges prepaid. ALLOWAY shall complete such repair or replacement within a reasonable time after ALLOWAY receives the product. THERE ARE NO OTHER REMEDIES UNDER THIS WARRANTY. THE REMEDY OF REPAIR OR REPLACEMENT IS THE SOLE AND EXCLUSIVE REMEDY UNDER THIS WARRANTY.

THERE ARE NO WARRANTIES, WHICH EXTEND BEYOND THE DESCRIPTION ON THE FACE OF THIS WARRANTY. ALLOWAY MAKES NO OTHER WARRANTY, EXPRESS OR IMPLIED, AND ALLOWAY SPECIFICALLY DISCLAIMS ANY IMPLIED WARRANTY OF MERCHANTABILITY AND/OR ANY IMPLIED WARRANTY OF FITNESS FOR A PARTICULAR PURPOSE.

ALLOWAY shall not be liable for any incidental or consequential losses, damages or expenses, arising directly or indirectly from the product, whether such claim is based upon breach of contract, breach of warranty, negligence, strict liability in tort or any other legal theory. Without limiting the generality of the foregoing, Alloway specifically disclaims any damages relating to (i) lost profits, business, revenues or goodwill; (ii) loss of crops; (iii) loss because of delay in harvesting; (iv) any expense or loss incurred for labor, supplies, substitute machinery or rental; or (v) any other type of damage to property or economic loss.

This Warranty is subject to any existing conditions of supply, which may directly affect ALLOWAY'S' ability to obtain materials or manufacture replacement parts.

No agent, representative, dealer, distributor, serviceperson, salesperson, or employee of any company; including without limitation, ALLOWAY, its authorized dealers, distributors, and service centers, is authorized to alter, modify, or enlarge this Warranty.

This Warranty is effective only if the warranty registration card is returned within ten (10) days.

Answers to any questions regarding warranty service and locations may be obtained by contacting:

Alloway  
4230 14<sup>th</sup> Ave. NW  
 Fargo, North Dakota 58102  
 701-356-4983



## WARRANTY

ALLOWAY STANDARD, d/b/a ALLOWAY, warrants this product to be free from defect in material and workmanship for a period of ninety (90) days from the date of delivery of the product to the original purchaser.

Under no circumstances will this Warranty apply in the event that the product, in the good faith opinion of ALLOWAY, has been subjected to improper operation, improper maintenance, misuse, or an accident. This Warranty does not cover normal wear or tear, or normal maintenance items.

This Warranty is extended solely to the original purchaser of the product. Should the original purchaser sell or otherwise transfer this product to a third party, this Warranty does not transfer to the third party purchaser in any way. There are no third party beneficiaries of this Warranty.

ALLOWAY'S' obligation under this Warranty is limited to, at ALLOWAY'S option, the repair or replacement, free of charge, of the product if ALLOWAY, in its sole discretion, deems it, to be defective or in noncompliance with this Warranty. The product must be returned to ALLOWAY with proof of purchase within thirty (30) days after such defect or noncompliance is discovered or should have been discovered, routed through the dealer and distributor from whom the purchase was made, transportation charges prepaid. ALLOWAY shall complete such repair or replacement within a reasonable time after ALLOWAY receives the product. THERE ARE NO OTHER REMEDIES UNDER THIS WARRANTY. THE REMEDY OF REPAIR OR REPLACEMENT IS THE SOLE AND EXCLUSIVE REMEDY UNDER THIS WARRANTY.

THERE ARE NO WARRANTIES WHICH EXTEND BEYOND THE DESCRIPTION ON THE FACE OF THIS WARRANTY. ALLOWAY MAKES NO OTHER WARRANTY, EXPRESS OR IMPLIED, AND ALLOWAY SPECIFICALLY DISCLAIMS ANY IMPLIED WARRANTY OF MERCHANTABILITY AND/OR ANY IMPLIED WARRANTY OF FITNESS FOR A PARTICULAR PURPOSE.

ALLOWAY shall not be liable for any incidental or consequential losses, damages or expenses, arising directly or indirectly from the product, whether such claim is based upon breach of contract, breach, of warranty, negligence, strict liability in tort or any other legal theory. Without limiting the generality of the foregoing, Alloway specifically disclaims any damages relating to (i) lost profits, business, revenues or goodwill; (ii) loss of crops; (iii) loss because of delay in harvesting; (iv) any expense or loss incurred for labor, supplies, substitute machinery or rental; or (v) any other type of damage to property or economic loss.

This Warranty is subject to any existing conditions of supply, which may directly affect ALLOWAY'S' ability to obtain materials or manufacture replacement parts.

No agent, representative, dealer, distributor, service person, salesperson, or employee of any company, including without limitation, ALLOWAY, Its authorized dealers, distributors, and service centers, IS authorized to alter, modify, or enlarge this Warranty.

Answers to any questions regarding warranty service and locations may be obtained by contacting:

Alloway  
4230 14<sup>th</sup> Ave. NW  
Fargo, North Dakota 58102  
701-356-4983



**PART NUMBER**  
**500-3-2219**

**Alloway Equipment  
Company**

4230 14th Ave NW.  
Fargo, ND 58102

877-275-8714 tel

701-356-4985 fax

**alloway** STANDARD