

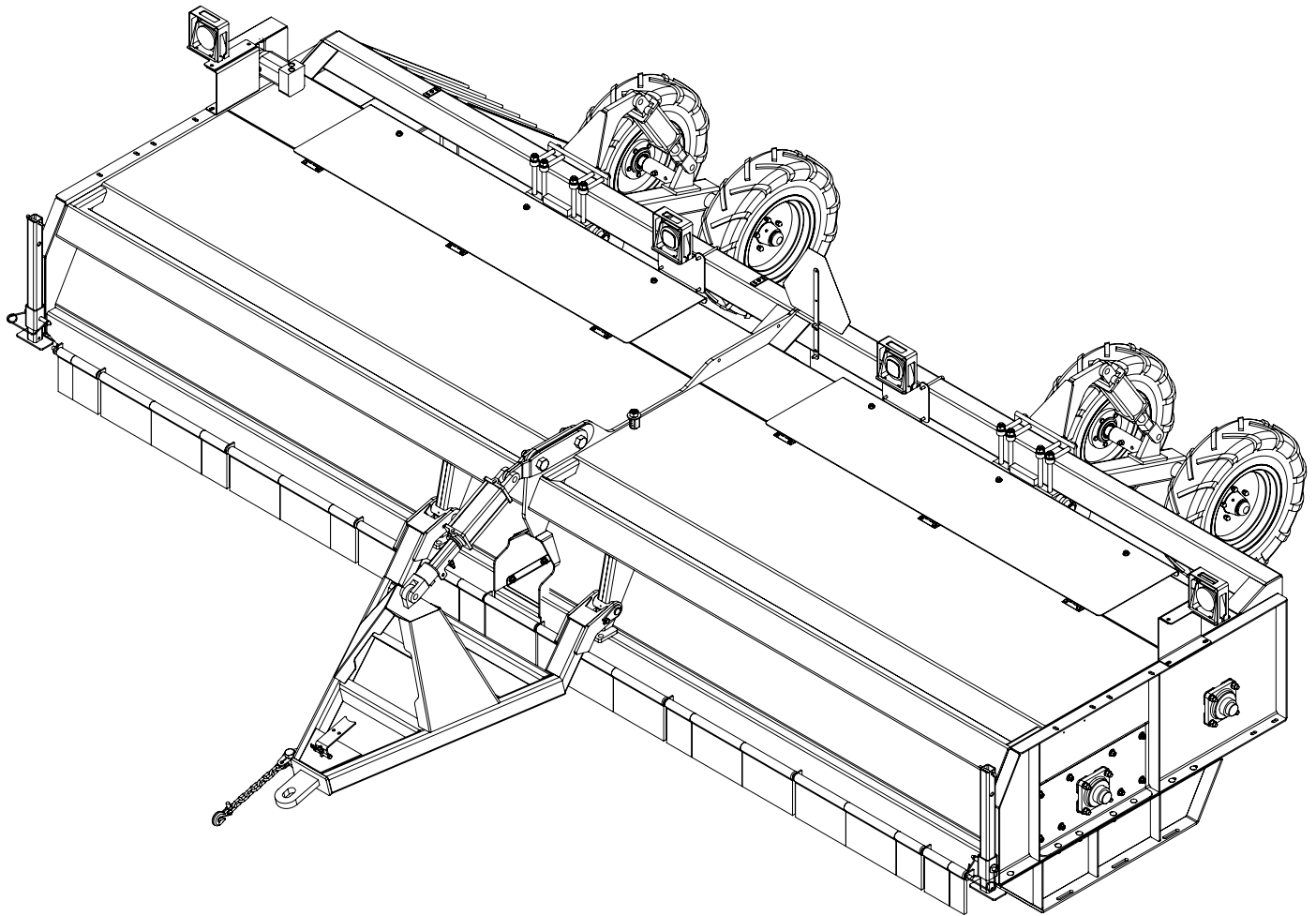

**2009 - 2010**

# **WINDROW SHREDDER**



# **OPERATOR'S MANUAL**

## TO THE DEALER:

Assembly and proper installation of this product is the responsibility of the Alloway dealer. Read manual instructions and safety rules. Make sure all items on the Dealer's Pre-Delivery and Delivery Check Lists in the Operator's Manual are completed before releasing equipment to the owner.

The dealer must complete the Warranty Registration included in this manual. Both dealer and customer must sign the registration which certifies that all Dealer Check List items have been completed. The dealer is to return the prepaid postage portion to Alloway, give one copy to the customer, and retain one copy. **Note: Warranty credit is subject to this form being completed and returned.**

## TO THE OWNER:

Read this manual before operating your Alloway equipment. The information presented will prepare you to do a better and safer job. Keep this manual handy for ready reference. Require all operators to read this manual carefully and become acquainted with all the adjustment and operating procedures before attempting to operate. Replacement manuals can be obtained from your dealer.

The equipment you have purchased has been carefully engineered and manufactured to provide dependable and satisfactory use. Like all mechanical products, it will require cleaning and upkeep. Lubricate the unit as specified. Observe all safety information in this manual and safety decals on the equipment.

For service, your authorized Alloway dealer has trained mechanics, genuine Alloway service parts, and the necessary tools and equipment to handle all your needs.

Use only genuine Alloway service parts. Substitute parts will void the warranty and may not meet standards required for safe and satisfactory operation. Record the model number and serial number of your equipment in the spaces provided:

**Model:** \_\_\_\_\_ **Date of Purchase** \_\_\_\_\_

**Serial Number: (see Safety Decal section for location)** \_\_\_\_\_

Provide this information to your dealer to obtain correct repair parts.

Throughout this manual, the term **IMPORTANT** is used to indicate that failure to observe can cause damage to equipment. The terms **CAUTION**, **WARNING** and **DANGER** are used in conjunction with the Safety-Alert Symbol, (a triangle with an exclamation mark), to indicate the degree of hazard for items of personal safety.



This Safety-Alert Symbol indicates a hazard and means **ATTENTION! BECOME ALERT! YOUR SAFETY IS INVOLVED!**



Indicates an imminently hazardous situation that, if not avoided, will result in death or serious injury.



Indicates a potentially hazardous situation that, if not avoided, could result in death or serious injury, and includes hazards that are exposed when guards are removed



Indicates a potentially hazardous situation that, if not avoided, may result in minor or moderate injury.

**IMPORTANT**

Indicates that failure to observe can cause damage to equipment.

**NOTE**

Indicates helpful information.

# TABLE OF CONTENTS

INTRODUCTION .....	Inside Front Cover
GENERAL INFORMATION .....	1
SPECIFICATIONS .....	2
SAFETY RULES .....	3-6
CHECK LISTS .....	7
SAFETY DECALS .....	8-9
OPERATOR SIGN-OFF RECORD .....	10
OPERATION .....	11
FIELD OPERATION.....	17
ADDITIONAL EQUIPMENT .....	24
SHREDDER STORAGE .....	25
SERVICE & MAINTENANCE .....	26
TROUBLE SHOOTING .....	37
ASSEMBLY .....	38
INDEX TO PARTS LISTS .....	43
BOLT TORQUE CHART .....	76
BOLT SIZE CHART & ABBREVIATIONS .....	77
NUMERICAL INDEX .....	88-90
INDEX .....	91
NOTES .....	92-93
REPLACEMENT PARTS WARRANTY .....	94
PRODUCT WARRANTY.....	95

---

## GENERAL INFORMATION

The purpose of this manual is to assist you in operating and maintaining your Windrow Shredder. Read it carefully. It furnishes information and instructions that will help you achieve years of dependable performance. These instructions have been compiled from extensive field experience and engineering data. Some information may be general in nature due to unknown and varying operating conditions. However, through experience and these instructions, you should be able to develop procedures suitable to your particular situation.

The illustrations and data used in this manual were current at the time of printing, but due to possible inline production changes, your machine may vary

Slightly in detail. We reserve the right to redesign and change the machines as may be necessary without notification.

### **WARNING**

- **Some illustrations in this manual show the Windrow Shredder with safety shields removed to provide a better view. The Windrow Shredder should never be operated with any safety shielding removed.**

Throughout this manual, references are made to right and left direction. These are determined by standing behind the equipment facing the direction of forward travel.

# SPECIFICATIONS

Maximum Outside Body Width:

13'	180 in. (4.57 m)
15'	204 in. (5.19 m)
18'	240 in. (6.10 m)
20'	264 in. (6.71 m)
22'	288 in. (7.32 m)

Maximum Outside Body Height:

13' - 22'	52 in. (1.33 m)
-----------	-----------------

Maximum Outside Body Depth:

13' - 22'	102 in. (2.60 m)
-----------	------------------

Cutting Height ..... 3 in. - 18 in. (0.08 m - 0.46 m)

Width of Cut:

13'	156 in. (3.97 m)
15'	180 in. (4.58 m)
18'	216 in. (5.49 m)
20'	240 in. (6.10 m)
22'	264 in. (6.71 m)

Knife: Retention ..... Bolt-On Cup

Knife: Pattern ..... Spiral

13'	72
15'	84
18'	104
20'	116
22'	128

Recommended Tire Size: ..... Traction Tires (7.60 x 15) or (12.4 x 24)

Recommended Tire Inflation Pressure:

7.60 x 15	40 psi.
12.4 x 24	32 psi.

Rotor: Speed ..... 1000 RPM Dynamically Balanced

Rotor: Size

13' - 18'	10" x 1/4" DOM Tubing
20' - 22'	10" x 3/8" DOM Tubing

Drive: PTO ..... 1-3/4" or 1-3/8" Slip Clutch (1000 RPM)

Auger: Size ..... 1/4 x 12 x 18 Pitch

Auger: RPM ..... 350 RPM - 450 RPM

Tractor Horse Power ..... Approx. 8 Hp per foot

Available Hitches ..... Pull Type or 3-Point (Category II or III)

Hood Type ..... Tri-Lateral-Seamless

Body Thickness ..... 1/4" Hot Rolled Mid Steel Grade 50

Weight of Shredder (approximate):

13'	3900 lbs. (1800 kg)
15'	4200 lbs. (2000 kg)
18'	4800 lbs. (2200 kg)
20'	5200 lbs. (2400 kg)
22'	5600 lbs. (2600 kg)



# SAFETY RULES

**ATTENTION! BECOME ALERT! YOUR SAFETY IS INVOLVED!**



Safety is a primary concern in the design and manufacture of our products. Unfortunately, our efforts to provide safe equipment can be wiped out by a single careless act of an operator.

In addition to the design and configuration of equipment, hazard control and accident prevention are dependent upon the awareness, concern, prudence and proper training of personnel involved in the operation, transport, maintenance and storage of equipment.

It has been said *"The best safety device is an informed, careful operator."* We ask you to be that kind of an operator.

The designed and tested safety of this equipment depends on it being operated within the limitations as explained in this manual.

## TRAINING

- **Safety instructions are important! Read all attachment and power unit manuals; follow all safety rules and safety decal information. (Replacement manuals are available from dealer). Failure to follow instructions or safety rules can result in serious injury or death.**
- **If you do not understand any part of this manual and need assistance, see your dealer.**
- **Know your controls and how to stop engine and attachment quickly in an emergency.**
- **Operators must be instructed in and be capable of the safe operation of the equipment, its attachments and all controls. Do not allow anyone to operate this equipment without proper instructions.**
- **Keep hands and body away from pressurized lines. Use paper or cardboard, not body parts to check for leaks. Wear safety goggles. Hydraulic fluid under pressure can easily penetrate skin and will cause serious injury or death.**
- **Make sure that all operating and service personnel know that in the event hydraulic fluid penetrates skin, it must be surgically removed as soon as possible by a doctor familiar with this form of injury, or gangrene, serious injury or death will result. CONTACT A PHYSICIAN IMMEDIATELY IF FLUID ENTERS SKIN OR EYES. DO NOT DELAY.**
- **Never allow children or untrained persons to operate equipment.**

## PREPARATION

- **Check that all hardware is tight and properly installed. Always tighten to torque chart specifications unless instructed otherwise in this manual.**
- **Air in hydraulic systems can cause erratic operation and allows loads or equipment components to drop unexpectedly. Before operating or allowing anyone to approach the equipment, purge any air in the system by operating all hydraulic functions several times after connecting equipment, connecting hoses, or doing any hydraulic maintenance.**
- **Make sure all hydraulic hoses, fittings and valves are in good condition and not leaking before starting power unit or using equipment. Check and route hoses carefully to prevent damage. Hoses must not be twisted, bent sharply, kinked, frayed, pinched, or come into contact with any moving parts. Operate moveable components through full operational range to check clearances. Replace any damaged hoses immediately.**
- **Always wear relatively tight and belted clothing to avoid entanglement in moving parts. Wear sturdy, rough-soled work shoes and protective equipment for eyes, hair, hands, hearing and head; and respirator or filter mask where appropriate.**
- **Ensure implement is properly attached, adjusted and in good operating condition.**
- **Make sure spring-activated locking pin or collar slides freely and is seated firmly in tractor PTO spline groove.**
- **Before starting power unit, check all equipment driveline guards for damage and make sure they rotate freely on all drivelines. Replace any damaged guards. If guards do not rotate freely on drivelines, repair and replace bearings before operating.**
- **Power unit must be equipped with ROPS or ROPS CAB and seat belt. Keep seat belt securely fastened. Falling off power unit can result in death from being run over or crushed. Keep foldable ROPS systems in "locked up" position at all times.**
- **Connect PTO driveline directly to power unit PTO shaft. Never use adapter sleeves or adapter shafts. Adapters can cause driveline failures due to incorrect spline or incorrect operating length and can result in personal injury or death.**

# SAFETY RULES



**ATTENTION! BECOME ALERT! YOUR SAFETY IS INVOLVED!**



- Inspect rubber flaps and swing rod before each use. Replace if damaged or missing. Flaps must pivot and hang freely so there are no gaps. Do not put equipment into service until repaired.
- Remove accumulated debris from this equipment, tractor and engine to avoid fire hazard.
- Ensure all safety decals are installed. Replace if damaged. (See Safety Decals section for location.)
- Ensure shields and guards are properly installed and in good condition. Replace if damaged.
- A minimum 20% of tractor and equipment weight must be on tractor front wheels when attachments are in transport position. Without this weight, tractor could tip over, causing personal injury or death. The weight may be attained with a loader, front wheel weights, ballast in tires or front tractor weights. When attaining the minimum 20% weight on the front wheels, you must not exceed the Roll Over Protection Structure (ROPS) weight certification. Weigh the tractor and equipment. Do not estimate.
- Make sure hydraulic hoses and cylinders are fully purged of air before operating. Keep all persons away and fill the system by raising and lowering all functions several times. Air in the system can allow components to fall unexpectedly.
- Inspect and clear area of stones, branches, or other hard objects that might be thrown, causing injury or damage.

---

## TRANSPORTING

- Power unit must be equipped with ROPS or ROPS cab and seat belt. Keep seat belt securely fastened. Falling off power unit can result in death from being run over or crushed. Keep foldable ROPS systems in "locked up" position at all times.
- Always sit in power unit seat when operating controls or starting engine. Securely fasten seat belt, place transmission in neutral, engage brake, and ensure all other controls are disengaged before starting power unit engine.
- A minimum 20% of tractor and equipment weight must be on the tractor front wheels when attachments are in transport position. Without this weight, tractor could tip over, causing personal injury or death.

The weight may be attained with a loader, front wheel weights, ballast in tires or front tractor weights. Weigh the tractor and equipment. Do not estimate.

- Always attach safety chain to tractor drawbar when transporting unit.
- Always raise unit and install transport locks before transporting. Leak down or failure of mechanical or hydraulic system can cause equipment to drop.
- Never exceed 20 MPH during transport. See the Speed vs. Weight Ratio Table in "Field Operation, Transporting the Unit" for proper tow vehicle to machine weight ratios.
- Watch for hidden hazards on the terrain.
- Always comply with all state and local lighting and marking requirements.
- Never allow riders on power unit or attachment.
- Do not operate PTO during transport.
- Look down and to the rear and make sure area is clear before operating in reverse.
- Do not operate or transport on steep slopes.
- Use extreme care and reduce ground speed on slopes and rough terrain.
- Do not operate or transport equipment while under the influence of alcohol or drugs.

## OPERATION

- Equipment may be pictured with covers open for instructional purposes. Never operate equipment with covers open.
- Do not allow bystanders in the area when operating, attaching, removing, assembling, or servicing equipment.
- Do not allow anyone to stand between tractor and unit when backing up to unit.
- Never go underneath equipment (lowered to the ground or raised) unless it is properly blocked and secured. Never place any part of the body underneath equipment or between moveable parts even when the engine has been turned off. Hydraulic system leak down, hydraulic system failures, mechanical failures, or movement of control levers can cause equipment to drop or rotate unexpectedly and cause severe injury or death. Follow Operator's Manual instructions for working underneath and blocking requirements or have work done by a qualified dealer.

*(Safety Rules continued on next page)*

PN-50730431 (12/09)



# SAFETY RULES

**ATTENTION! BECOME ALERT! YOUR SAFETY IS INVOLVED!**



*(Safety Rules continued from previous page)*

- Keep bystanders away from equipment.
- Do not operate or transport equipment while under the influence of alcohol or drugs.
- Operate only in daylight or good artificial light.
- Avoid contact with electrical wires.
- Keep hands, feet, hair, and clothing away from equipment while engine is running. Stay clear of all moving parts.
- Always comply with all state and local lighting and marking requirements.
- Never allow riders on power unit or attachment.
- Power unit must be equipped with ROPS or ROPS cab and seat belt. Keep seat belt securely fastened. Falling off power unit can result in death from being run over or crushed. Keep foldable ROPS systems in "locked up" position at all times.
- Always sit in power unit seat when operating controls or starting engine. Securely fasten seat belt, place transmission in neutral, engage brake, and ensure all other controls are disengaged before starting power unit engine.
- Operate tractor PTO at the RPM speed stated in "Specifications" section.
- Do not operate PTO during transport.
- Look down and to the rear and make sure area is clear before operating in reverse.
- Do not operate or transport on steep slopes.
- Do not stop, start, or change directions suddenly on slopes.
- Use extreme care and reduce ground speed on slopes and rough terrain.
- Watch for hidden hazards on the terrain during operation.
- Stop power unit and equipment immediately upon striking an obstruction. Turn off engine, remove key, inspect, and repair any damage before resuming operation.

- Always connect safety chain from equipment to towing vehicle when transporting.
- **AVOID INJURY OR DEATH FROM POWER LINES:**
  - Stay away from power lines.
  - Electrocution can occur without direct contact.
  - Check clearances before raising implement.
  - Do not leave the operator's seat if any part of the tractor or implement contacts electric lines.
- Before servicing, adjusting, repairing or unplugging, stop tractor engine, place all controls in neutral, set park brake, remove ignition key, and wait for all moving parts to stop.
- Before working underneath a raised implement, read and follow all Operator's Manual instructions and safety rules. Implement must be attached to tractor. Lift cylinder locks must be installed and lift cylinders lowered against locks. Hydraulic system leak down, hydraulic system failures, or movement of control levers can cause equipment to drop unexpectedly and cause severe injury or death.

---

## MAINTENANCE

- Before servicing, adjusting, repairing or unplugging, stop tractor engine, place all controls in neutral, set park brake, remove ignition key, and wait for all moving parts to stop.
- Before working underneath a raised implement, read and follow all Operator's Manual instructions and safety rules. Implement must be attached to tractor. Lift cylinder locks must be installed and lift cylinders lowered against locks. Hydraulic system leak down, hydraulic system failures, or movement of control levers can cause equipment to drop unexpectedly and cause severe injury or death.
- Service and maintenance work not covered in OWNER SERVICE must be done by a qualified dealership. Special skills, tools, and safety procedures may be required. Failure to follow these instructions can result in serious injury or death.
- Do not modify or alter or permit anyone else to modify or alter the equipment or any of its components in any way.
- Your dealer can supply original equipment hydraulic accessories and repair parts. Substitute parts may not meet original equipment specifications and may be dangerous.

# SAFETY RULES



**ATTENTION! BECOME ALERT! YOUR SAFETY IS INVOLVED!**



- Always wear relatively tight and belted clothing to avoid entanglement in moving parts. Wear sturdy, rough-soled work shoes and protective equipment for eyes, hair, hands, hearing and head; and respirator or filter mask where appropriate.
- Do not allow other people in the area when operating, attaching, removing, assembling or servicing equipment.
- Never go underneath equipment lowered to the ground or raised, unless it is properly blocked and secured. Never place any part of the body underneath equipment or between moveable parts even when the engine has been turned off. Hydraulic system leak down, hydraulic system failures, mechanical failures or movement of control levers can cause equipment to drop or rotate unexpectedly and cause severe injury or death. Follow Operator's Manual instructions for working underneath and blocking requirements, or have work done by a qualified dealer.
- Ensure implement is properly attached, adjusted and in good operating condition.
- Never perform service or maintenance with engine running.
- Make sure hydraulic hoses and cylinders are fully purged of air before operating. Keep all persons away and fill the system by raising and lowering all functions several times. Air in the system can allow components to fall unexpectedly.
- Do not open doors to inspect auger with engine running or hydraulic control levers engaged.

- Keep all persons away from operator control area while performing adjustments, service or maintenance.
- Make certain all movement of implement components has stopped before approaching for service.
- Do not handle blades with bare hands. Careless or improper handling may result in serious injury.
- Tighten all bolts, nuts and screws to torque chart specifications. Check that all cotter pins are installed securely to ensure equipment is in a safe condition before operating.
- Ensure all safety decals are installed. Replace if damaged. (See Safety Decals section for location.)
- Ensure shields and guards are properly installed and in good condition. Replace if damaged.
- Do not disconnect hydraulic lines until machine is securely blocked or placed in lowest position and system pressure is released by operating all valve control levers.

---

## STORAGE

- Follow manual instructions for storage.
- Keep children and bystanders away from storage area.



# CHECK LISTS

## PRE-DELIVERY CHECK LIST

(DEALER'S RESPONSIBILITY)

Inspect the equipment thoroughly after assembly to ensure it is set up properly before delivering it to the customer.

The following check lists are a reminder of points to inspect. Check off each item as it is found satisfactory or after proper adjustment is made.

- Check that all safety decals are installed and in good condition. Replace if damaged.
- Check that shields and guards are properly installed and in good condition. Replace if damaged.
- Check that PTO shaft is properly installed.
- Properly attach implement to tractor and make all necessary adjustments.
- Check all bolts to be sure they are tight.
- Check wheel bolts for proper torque.
- Check that all cotter pins and safety pins are properly installed. Replace if damaged.
- Check and grease all lubrication points as identified in "Service, lubrication information."
- Check the level of gearbox fluids before delivery. Service, if required, as specified in the "Service, lubrication information."
- Check that tractor hydraulic reservoir has been serviced and that hydraulic system and all functions have been operated through full cylinder stroke to purge air from system.
- After pressurizing and operating all Shredder functions, stop tractor and make sure there are no leaks in the hydraulic system. Follow all safety rules when checking for leaks.

## DELIVERY CHECK LIST

(DEALER'S RESPONSIBILITY)

- Show customer how to make adjustments and select proper PTO speed.
- Show customer how to make adjustments.
- Instruct customer how to lubricate and explain importance of lubrication.
- Point out the safety decals. Explain their meaning and the need to keep them in place and in good condition. Emphasize the increased safety hazards when instructions are not followed.
- Present Operator's Manual and request that customer and all operators read it before operating equipment. Point out the manual safety rules, explain their meanings and emphasize the increased safety hazards that exist when safety rules are not followed.
- Extended & Retracted Length.
- Show customer how to make sure driveline is properly installed and that spring-activated locking pin or collar slides freely and is seated in groove on tractor PTO shaft.
- Show customer the safe, proper procedures to be used when mounting, dismounting, and storing equipment.
- Explain to customer that when equipment is transported on a road or highway, safety devices should be used to give adequate warning to operators of other vehicles.
- Explain to customer that when equipment is transported on a road or highway, a Slow Moving Vehicle (SMV) sign should be used to provide adequate warning to operators of other vehicles.
- Explain to customer that when towing on a public road to comply with all state and local lighting/marketing laws and to use a safety tow chain.
- Make customer aware of optional equipment available so that customer can make proper choices as required.
- Point out all guards and shields. Explain their importance and the safety hazards that exist when not kept in place and in good condition.

**SAFETY & INSTRUCTIONAL DECALS**  
**ATTENTION! BECOME ALERT! YOUR SAFETY IS INVOLVED!**  
**Replace Immediately If Damaged!**

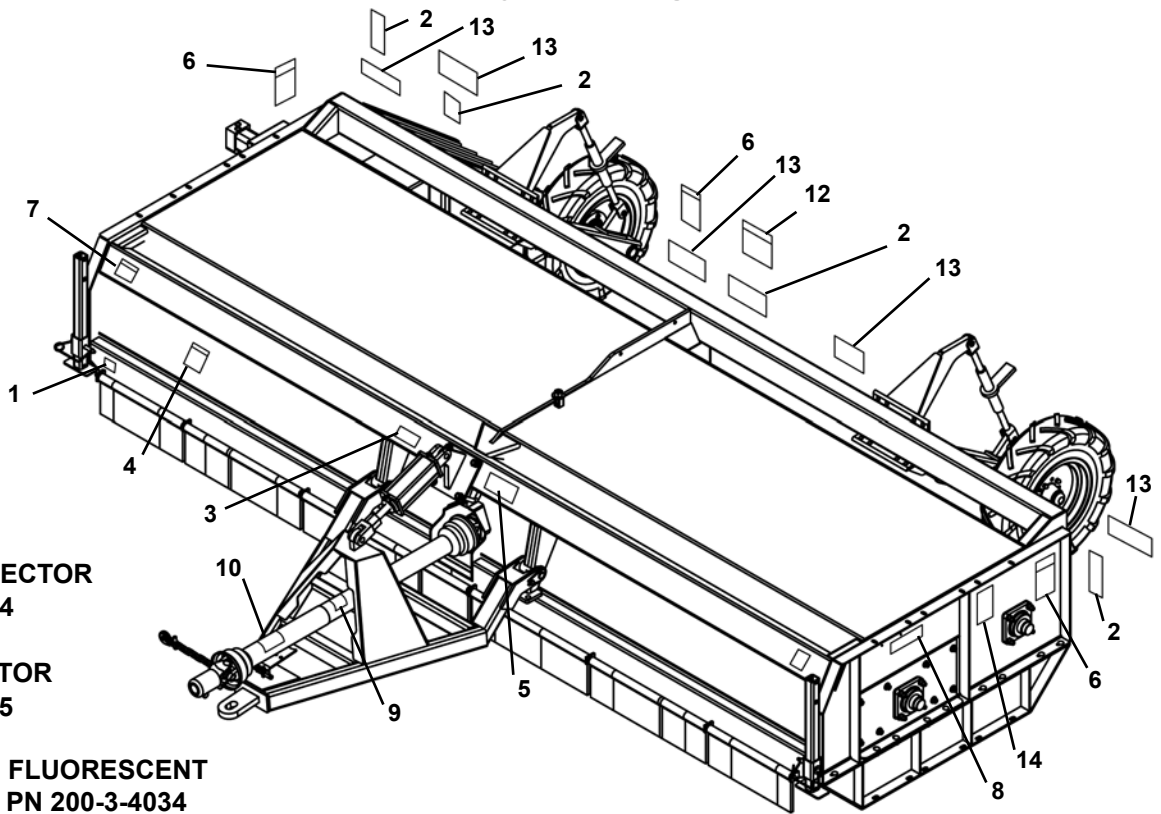

**1 - AMBER REFLECTOR**  
**PN 200-3-4004**

**2 - RED REFLECTOR**  
**PN 200-3-4005**

**13 - RED-ORANGE FLUORESCENT REFLECTOR PN 200-3-4034**

**3 - Serial Number Plate**

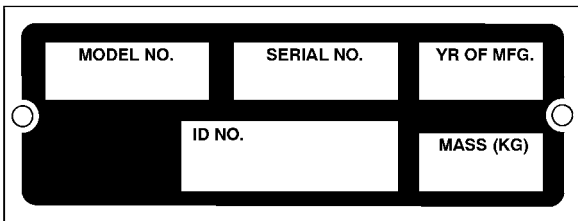

**4 - PN 500-3-0977**

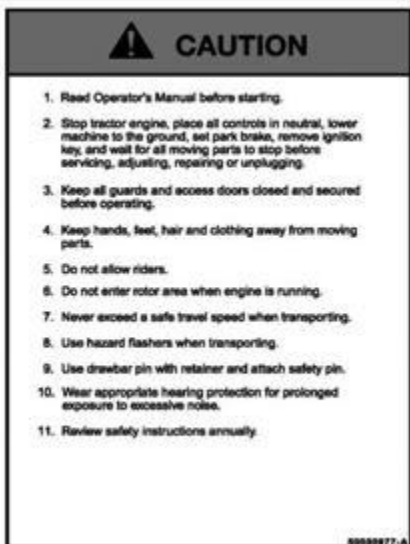

**5 - PN 500-3-0978**



**6 - PN 500-3-0982**



*(Safety Decals continued on next page)*

**SAFETY & INSTRUCTIONAL DECALS**
  
**ATTENTION! BECOME ALERT! YOUR SAFETY IS INVOLVED!**  
**Replace Immediately If Damaged!**

**⚠ DANGER**



**GUARD MISSING.  
DO NOT OPERATE.**

**⚠ DANGER**



**GUARD MISSING.  
DO NOT OPERATE.**  
33347E

**⚠ DANGER**

**9 - PN 33347**

**⚠ WARNING**

**MANUAL CONTAINER AND MANUAL ARE MISSING**

- REPLACE AND READ BEFORE OPERATING.
- KEEP MANUAL CONTAINER AND MANUAL MOUNTED IN THIS LOCATION. (Available from dealer or call 1-877-275-8714.)

**FAILURE TO FOLLOW MANUAL INSTRUCTIONS AND SAFETY RULES CAN RESULT IN SERIOUS INJURY OR DEATH.** 506-3-0192

**8 - PN 50630192**



**14 - PN 100-3-1367**

**10 - PN 18864**

**⚠ DANGER**



**ROTATING DRIVELINE  
CONTACT CAN CAUSE DEATH  
KEEP AWAY!**

**DO NOT OPERATE WITHOUT-**

- ALL DRIVELINE GUARDS, TRACTOR AND EQUIPMENT SHIELDS IN PLACE
- DRIVELINES SECURELY ATTACHED AT BOTH ENDS
- DRIVELINE GUARDS THAT TURN FREELY ON DRIVELINE

18864B

**⚠ WARNING**



**THROWN OBJECT HAZARD**

**To prevent serious injury or death:**

1. Stay away from the front of machine when operating.
2. Keep others away.
3. Keep deflectors in good condition when operating.

505-3-0314

**7 - PN 50530314**

**⚠ WARNING**



**HIGH-PRESSURE FLUID HAZARD**

**To prevent serious injury or death:**

1. Relieve pressure on system before repairing, adjusting or disconnecting.
2. Wear proper hand and eye protection when searching for leaks. Use wood or cardboard instead of hands.
3. Keep all components in good repair.

505-3-0315

**12 - PN 50530315**



# OPERATION

Safety is a primary concern in the design and manufacture of our products. Unfortunately, our efforts to provide safe equipment can be wiped out by an operator's single careless act.

In addition to the design and configuration of equipment, hazard control and accident prevention are dependent upon the awareness, concern, judgment, and proper training of personnel involved in the operation, transport, maintenance and storage of equipment.

It has been said "The best safety device is an informed, careful operator." We ask you to be that kind of operator.

- The Alloway Windrow Shredder is designed to pick up and shred crop and plant residue left in the field. Rotational power to the flails is provided by the tractor PTO.
- Place shredded material into Windrow for bailing.
- Be familiar with the Windrow shredder before starting.
- The owner is responsible for training operators in the safe operation of the Windrow shredder.

## **WARNING**

- **Safety instructions are important! Read all attachment and power unit manuals; follow all safety rules and safety decal information. (Replacement manuals are available from your Alloway dealer.) Failure to follow instructions or safety rules can result in serious injury or death.**
- **Never allow children or untrained persons to operate equipment.**
- **Make sure shields and guards are properly installed and in good condition. Replace if damaged.**
- **Keep hands, feet, hair, and clothing away from equipment while engine is running. Stay clear of all moving parts.**
- **Before dismounting power unit or performing any service or maintenance, follow these steps: disengage power to equipment, lower the 3-point hitch and all raised components to the ground, operate valve levers to release any hydraulic pressure, set parking brake, stop engine, remove key, and unfasten seat belt.**
- **Never allow riders on power unit or attachment.**
- **Do not allow bystanders in the area when operating, attaching, removing, assembling, or servicing equipment.**
- **Keep hands, feet, hair, and clothing away from equipment while engine is running. Stay clear of all moving parts.**

## **CAUTION**

- **Always sit in power unit seat when operating controls or starting engine. Securely fasten seat belt, place transmission in neutral, engage brake, and ensure all other controls are disengaged before starting power unit engine.**
- **Never allow riders on power unit or attachment.**
- **Keep bystanders away from equipment.**
- **Operate tractor PTO at the RPM speed stated in "Specifications" section.**
- **Always comply with all state and local lighting and marking requirements.**
- **Always wear relatively tight and belted clothing to avoid entanglement in moving parts. Wear sturdy, rough-soled work shoes and protective equipment for eyes, hair, hands, hearing, and head; and respirator or filter mask where appropriate.**

# Operation Continued

## PRINCIPAL COMPONENTS

The Alloway Flail Shredder consists of a large rotating drum with free-swinging steel flails attached. The flails pick up or strike crop residue or trash and shred it. Rotational power to the drum is provided by the tractor PTO through a gearbox in the center of the machine.

For removing the center strip of crop residue, an optional hydraulically driven blade can be installed under the cover in the center of the machine.

The flail shredder is designed to be used as a pull-type, semi-mounted, or 3-point mounted machine.

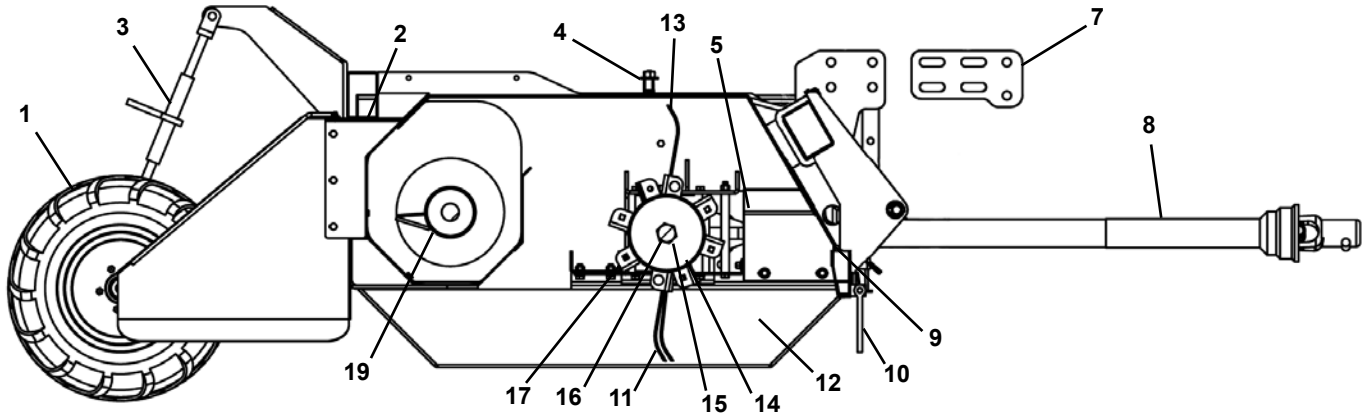

Figure 1a. Flail Shredder with 3-Pt Hitch Principal Components

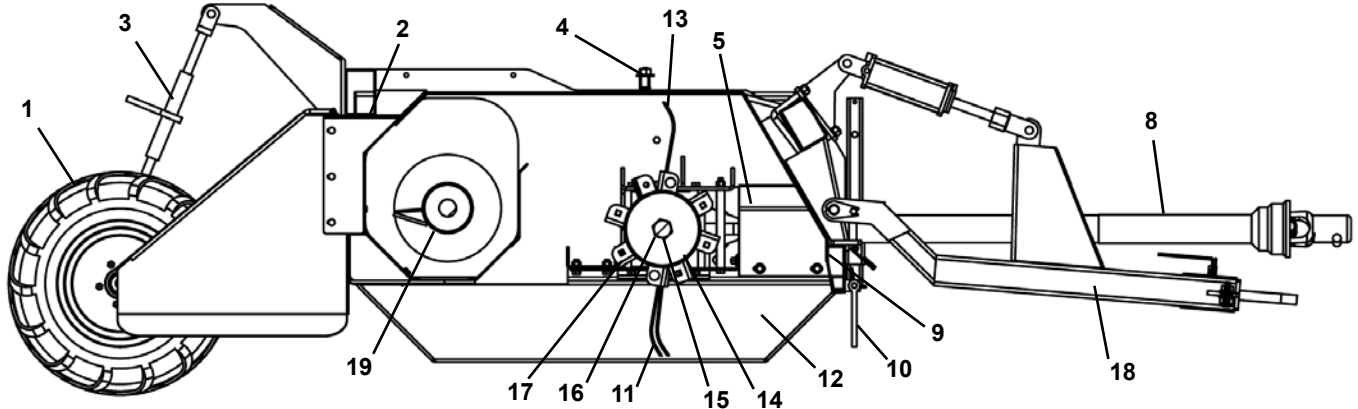

Figure 1b. Pull Type Flail Shredder Principal Components

- |                         |                        |
|-------------------------|------------------------|
| 1. Wheels               | 11. Flails             |
| 2. Rear hitch           | 12. Skid Plate         |
| 3. Ratchet              | 13. Cup Flail          |
| 4. Dipstick             | 14. Rotor (Flail Tube) |
| 5. Gearbox              | 15. End bearing        |
| 6. 3-Point hitch        | 16. Stub shaft         |
| 7. Floating mast        | 17. Flail Tube Clip    |
| 8. Driveline            | 18. Pull Type Hitch    |
| 9. Frame                | 19. Auger              |
| 10. Rubber shield flaps |                        |

## Operation Continued

### PRE-OPERATION CHECK LIST

(OWNER'S RESPONSIBILITY) *Continued*

#### IMPORTANT

■ This Pre-Operation Check List is provided for the operator. It is important to follow for both personal safety and maintenance of the flail shredder.

- \_\_\_ Check all lubrication points and grease as instructed in Lubrication Schedule, page 33.
- \_\_\_ Use only a tractor of adequate power and weight to pull the unit.
- \_\_\_ Check that the unit is properly attached to the tractor. On pull-type unit, be sure there is a mechanical retainer through the drawbar pin and the safety chain is installed. On 3-point hitch units, be sure retainers are used on the mounting pins.
- \_\_\_ Check oil level in gearbox. Add oil as required.
- \_\_\_ Check that the PTO driveline turns freely and that the driveline can telescope easily.
- \_\_\_ Check tire pressure. Bring to specified level.
- \_\_\_ Check flails. Inspect for damage or breakage. Make sure the swing freely on their mount. Repair or replace as required.
- \_\_\_ Check condition of cutter blade (if so equipped).
- \_\_\_ Inspect all hydraulic lines, hoses, couplers, and fittings. Tighten, repair, or replace any leaking or damaged components.
- \_\_\_ Install and secure all guards, doors, and covers.
- \_\_\_ Check PTO clutch operation (See Servicing Weasler Modular Friction Clutch, page 44).

### Choosing the Correct Equipment

To ensure safe and reliable operation of the flail shredder, use a tractor with the correct specifications. Use the following guidelines to select the correct tractor.

#### 1. Horsepower

Use Table 1 for selecting the tractor horsepower class appropriate for your unit's width.

Increase the horsepower level by 25 percent when operating in hilly, soft, or wet conditions.

#### 2. Tractor Weight

By following recommendations for tractor horsepower, the tractor will have sufficient weight to provide stability for unit during field operation or when transporting.

When using a 3-point mounted shredder, it is recommended that each tractor be equipped with a full complement of suitcase weights on the tractor front (see Figure 2 for example). This will provide the required front weight for turning and extra traction if equipped with front wheel assist.

Width	Minimum Horsepower
13'	100
15'	120
18'	140
20'	160
22'	180

**Table 1: Tractor Horsepower vs. Unit Width**

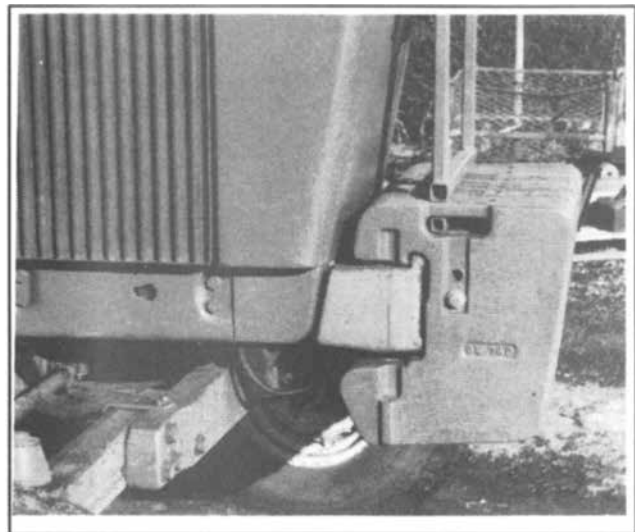

**Figure 2. DTractor Front Weights**

## Operation Continued

### Choosing the Correct Equipment (Cont'd)

#### 3. 3-Point Hitch

The 3-point hitch models require the tractor to be equipped with a Category II or Category III 3-point hitch. If the hitch can be converted from one to the other, use a Category III to provide a wider stance and more stability.

Use the upper pin hole for Category III and the lower hole for Category II as shown in Figure 3.

For easier attachment, use a quick hitch. If not using a quick hitch, use optional hitch extension.

#### 4. Load Sensing Hydraulics (3-Point models only)

Many newer tractors are equipped with "load sensing" hydraulics. The operator is responsible for setting the tractor hydraulic

system to provide "float" on the 3-point hitch. Refer to the tractor manual for specific instructions.

The "float" feature will allow the unit to follow the ground contours during operation. This applies to 3-point mounted machines only.



Figure 3. 3-Point Hitch Attachment

#### 5. Drawbar (Pull-type models only)

The tractor drawbar must be set to provide 16" - 20" (406 mm - 508 mm) between the end of the PTO shaft and the center of the drawbar pin for all and 1000 rpm PTO. See Figure 4. This dimension will provide the required clearance for the CV (Constant Velocity) joint on the front of the driveline.

#### IMPORTANT

- Do not use PTO shaft adapters. They will change the drawbar dimension and can cause driveline failures.

NOTE: On pull-type models, do not cut driveline.

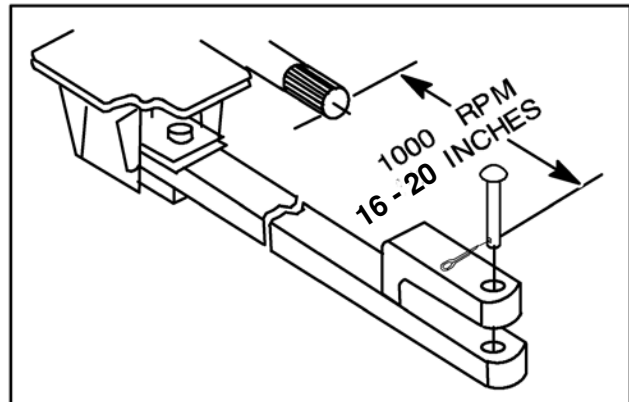

Figure 4. Drawbar Dimensions

### Break-in of the Flail Shredder

The following should be observed when operating the unit for the first time:

#### IMPORTANT

- Before operating the unit in the field, run the PTO clutch. See Servicing Weasler Modular Friction Clutch, page 44.

#### After operating for 1/2 hour

1. Check all nuts, bolts, and other fasteners. Tighten to specifications given in the Bolt Torque Chart, page 72.
2. Tighten wheel bolts to specifications given in the Bolt Torque Chart, page 72.

3. Check that the flails are in good condition and swing freely.
4. Check oil level in the gearbox. Add oil if needed.
5. Check that the PTO driveline shield turns freely.
6. Lubricate all grease points.
7. Check to see if auger is turning in correct direction.
8. Check auger speed - approximately 450 RPM.

#### After operating for 5 to 10 hours

1. Repeat Steps 1 to 5 above.
2. Follow regular service schedule as outlined in Service & Maintenance.



## Operation Continued

### PTO Driveline Length (3-Point & 2-Point models only)

The unit is equipped with a PTO driveline long enough to fit any tractor and 3-point linkage system.

The operator is responsible for measuring the dimensions of the driveline through its working range. These dimensions will indicate if the driveline requires shortening to operate on the particular tractor/unit attachment system. The operator must check dimensions before using the unit for the first time and each time a different tractor is used with the unit

Use the following procedure when determining driveline dimension:

1. Clear the area of bystanders, especially children.

### WARNING

- **Keep bystanders away from equipment.**
2. Attach the 3-point hitch to the unit but not the PTO driveline.
  3. Raise the unit until the tractor PTO and gearbox shafts are the same height.
  4. Measure the dimension between the shaft grooves on the tractor and implement ends. If this dimension is less than 34.81 inches, the shaft will require shortening.

5. Move the unit to its highest and lowest working position and measure this dimension again. The unit's shaft can telescope (see Figure 6) before it has been shortened.

6. If required, shorten the shaft to prevent bottoming out during use. NOTE: An extra inch of compression space in the shaft can eliminate bottoming out during use. Measure to make sure.

7. Use an abrasive wheel power saw to cut the male end of the shaft. Cut the same amount from both the splined shaft and the safety shield. See Figure 5. Use a file to remove any burrs from the cut end.

### IMPORTANT

- **Cut only the male end. Never cut the female end.**

8. Never cut more than 9 inches from the male end. Cutting 1 inch from the male end shortens both the minimum and maximum lengths by 1 inch.

9. Raise tractor all the way up and lower all the way down. Do not allow PTO to bottom out or pull apart. Contact Dealer if you have issues.

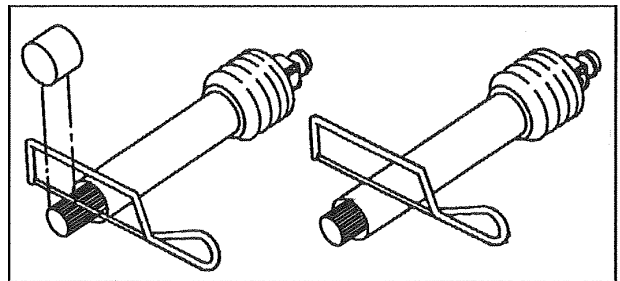

Figure 5. Cutting the Driveline Shaft

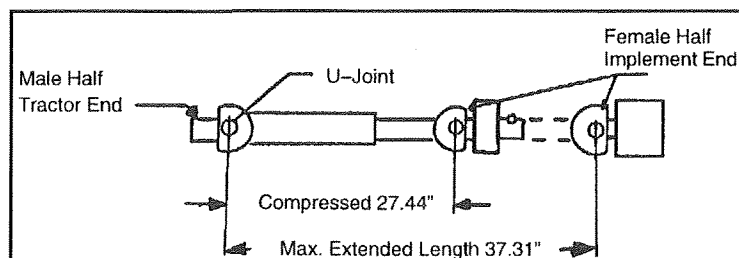

Figure 6. Driveline Dimension - 3-Pt Hitch

## Operation Continued

### Attaching the Shredder to the Tractor

1. Place unit on a level, dry area free of debris and other foreign object.

#### **WARNING**

- Keep bystanders away from equipment.

2. Clear the area of bystanders, especially children.

3. Provide enough clearance to back the tractor safely into the unit.

#### **CAUTION**

- Do not allow anyone to stand between tractor and unit when backing up to the unit.

#### 3-point and 2-point models:

4. Set the height of the 3-point hitch so that quick hitch claws are lower than the mounting pins.
5. Make sure 3-point hitch is set in the non-sway position. See tractor manual for details.
6. Align the claws under the mounting pins (see Figure 7) while backing up.

NOTE: For a Category II hitch, use the bottom hole for the center pin. For a Category III hitch, use the top hole for the center pin.

7. When the claws are under the pins, slowly raise the 3-point hitch. Make sure each mounting pin seats in its respective claw.
8. Release the claw retainer locks to secure the mounting pins in the claws.
9. Check the top link frame. It should be free to slide

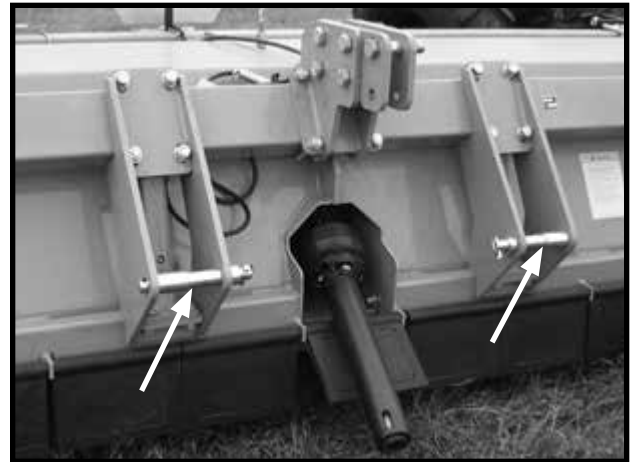

**Figure 7.** Attaching to 3-point model

in its mounting slots. This movement allows the unit to follow the ground contour when cresting a hill or going through a depression.

#### Pull-type model:

4. Use the ratchet (see Figure 8) on top of the hitch to set the hitch height.
5. Check and set the drawbar dimension.
6. Back the tractor up to the hitch.
7. Use a hardened drawbar pin that provides for a mechanical retainer, such as a Klik pin.
8. Attach a safety chain around the drawbar or cage to prevent unexpected separation. Provide sufficient slack for turning.
9. Use the ratchet to transfer the unit's weight to the drawbar.
10. Make sure the drawbar is pinned in its center position.

#### Attach PTO Driveline

11. Make sure the driveline telescopes easily and shields rotate freely.

#### **IMPORTANT**

- The drawbar may need repositioning to provide clearance for the driveline.



**Figure 8.** Attaching to Pull-type model

12. Attach the driveline to the tractor by retracting the locking collar. Slide the yoke over the shaft and push on the yoke until the lock collar clicks into position. Make sure the yoke is locked into position. See Figure 9.

#### Attach Hydraulics

13. Use a clean cloth to clean hose ends and area around the couplers on the tractor (Check direction of Rotation on Flighting).

## Operation *Continued*

### Attaching the Shredder to the Tractor (Cont'd)

14. Insert the hose male ends into the tractor couplers. Make sure hoses lock in place.

15. Route hoses along or over the hitch and secure in position with clips, tape, or plastic ties. Provide enough slack for turning and lifting.

#### Raise Stands

16. Use hitch ratchets or 3-point hitch to raise the front of the machine.

17. Unpin front frame stands. Raise and pin in their upper position. See Figure 10.



Figure 9. Belt Drive

### Removing the Shredder from the Tractor

1. Reverse the above procedure (Steps 1-17) when removing unit from the tractor.



Figure 10. Parking Stand

## Field Operation

The Alloway Flail Shredder is designed with the flexibility to operate well in almost any kind of crop and terrain conditions. However, the operator is responsible for being familiar with all operating and safety procedures and following them.

Each operator should review this Field Operation

section at the start of the season and as often as required to be familiar with the unit.

Operators should also review the PRE-OPERATION CHECK LIST, Attaching the Shredder to the Tractor, and Transporting the Unit.

### **WARNING**

- Safety instructions are important! Read all attachment and power unit manuals; follow all safety rules and safety decal information. (Replacement manuals are available from your Alloway dealer.) Failure to follow instructions or safety rules can result in serious injury or death.

- Never allow children or untrained persons to operate equipment.

- Make sure shields and guards are

properly installed and in good condition. Replace if damaged.

- Keep hands, feet, hair, and clothing away from equipment while engine is running. Stay clear of all moving parts.

- Before dismantling the power unit or performing any service or maintenance, follow these steps: disengage power to equipment, lower the 3-point hitch and all raised components to the ground, operate valve levers to release any hydraulic pressure, set parking brake, stop engine, remove key, and unfasten seat belt.

## Field Operation *Continued*

### **WARNING**

- Never allow riders on power unit or attachment.
- Do not allow bystanders in the area when operating, attaching, removing, assembling, or servicing equipment.
- Inspect and clear area of stones, branches, or other hard objects that might be thrown, causing injury or damage.
- Operators must be instructed in and be capable of the safe operation of the equipment, its attachments, and all controls. Do not allow anyone to operate this equipment without proper instructions.

### **CAUTION**

- Always sit in power unit seat when operating controls or starting engine. Securely fasten seat belt, place transmission in neutral, engage brake, and ensure all other controls are disengaged before starting power unit engine.
- Keep bystanders away from equipment.
- Operate tractor PTO at the RPM speed stated in “Specifications” section.
- Always comply with all state and local lighting and marking requirements.
- Always wear relatively tight and belted clothing to avoid entanglement in moving parts. Wear sturdy, rough-soled work shoes and protective equipment for eyes, hair, hands, hearing, and head; and respirator or filter mask where appropriate.

## Transporting the Unit

### **WARNING**

- Never allow riders on power unit or attachment.

### **CAUTION**

- Always comply with all state and local lighting and marking requirements.
1. Be sure all bystanders are clear of the unit.
  2. Be sure center cutter is disengaged and has stopped turning (if so equipped).
  3. Be sure the unit is securely attached to the tractor and all retainer pins are installed.
  4. Be sure safety chain is installed on pull-type model.
  5. Raise the machine.
  6. Clean the SMV emblem, lights, and reflectors and be sure they are working.

Road Speed	Fully equipped or loaded implement(s) weight relative to towing machine weight
Up to 32 km/h (20 mph)	1 to 1 or less
Upto16km/h (10 mph)	2 to 1 or less
Do not tow	more than 2 to 1

**Table 2: Speed vs. Weight Ratio**

7. Be sure you are in compliance with all applicable lighting and marking regulations when transporting. Check with your local authorities.
8. Never transport the unit faster than 20 mph (32 kmph). The ratio of the tractor weight to the shredder weight plays an important role in defining acceptable travel speed. Table 2 summarizes the recommended travel speed-to-weight ratio.

## Field Operation *Continued*

### Preparing for Operation

1. Pull into the field and position the unit in a level area.
2. Lower into operating position.
3. 3-Point hitch models: Set the 3-point so the quick hitch is vertical and the floating upper mast is forward.

### Flail Height

4. Set the unit to give a flail height of **at least 2-1/2 to 6 inches (75 to 150 mm)** above the ground. This will minimize the amount of stones and dirt picked up by the flails under all operating conditions.

**NOTE:** To avoid unnecessary wear on knives and related parts, never set the unit lower than the recommended setting.



**Figure 15.** Flail Height

### Set Operating Height

#### 3-Point hitch models

Use the ratchet on the cylinder stops on the rear struts and on third link of 3-point to set the unit height.



**Figure 16.** 3-Point Hitch Models

#### Pull-type models

Use the cylinders on the hitch and rear struts to set the unit height.



**Figure 17.** Pull-type Models

## Field Operation *Continued*

### 3-Point & 2-Point Hitch Models

1. Set lower 3-point arms in the free-float position.
2. Set the hitch in the non-swing position.
3. Set the hydraulic system to allow the 3-point to float. Refer to tractor manual for instructions.
4. **3-Point models only:** Be sure the floating mast is free to slide in its mounting frame to allow the machine to follow ground contours. Refer to Figure 18.

Floating Top Mast

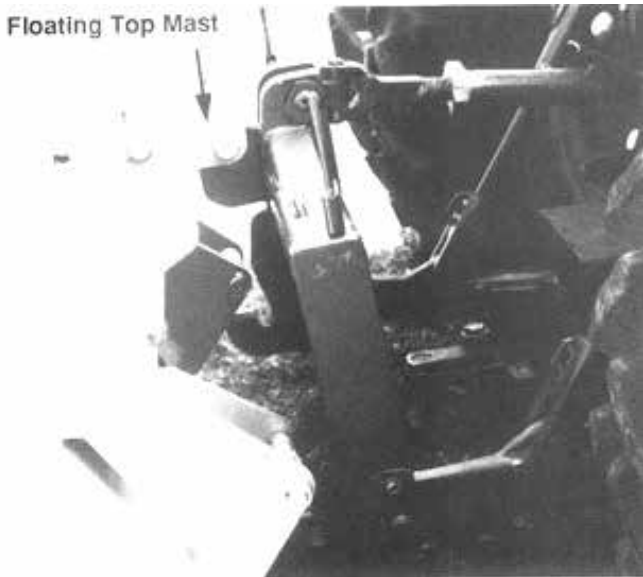

Figure 18. Free-float position

## Flails

### Cup Flails

The shredder is factory equipped with cup type flails.

Cup flails (Figure 19) can pick up material from the ground and work best in matted trash conditions.

The standard cup flail is 11 inches (279 mm) long and is used for most applications. Optional 7 and 9 inch (177 and 228 mm) flails are available to match the tip position to ground contour.

Attach optional cup flails as follows (see Figure 20):

1. Leave standard flails located between the rows.
2. Remove others and install shorter flails to follow ground contour. Be sure to mount the same size flails on opposite sides of the tube. Measure the row spacing and flail position carefully to minimize ground contact.

### Setting Flail Height

1. Be sure wheels are set to follow in the center of furrow row. **Set flails 3 to 6 inches (75 to 150 mm) above the ground.**
2. Align the unit with the working area on or between rows on flat farming.
3. **3-Point models:** Set the 3-point hitch so the wheels carry only a small portion of the unit's weight and act more as stabilizing wheels. See tractor manual for setting hitch.

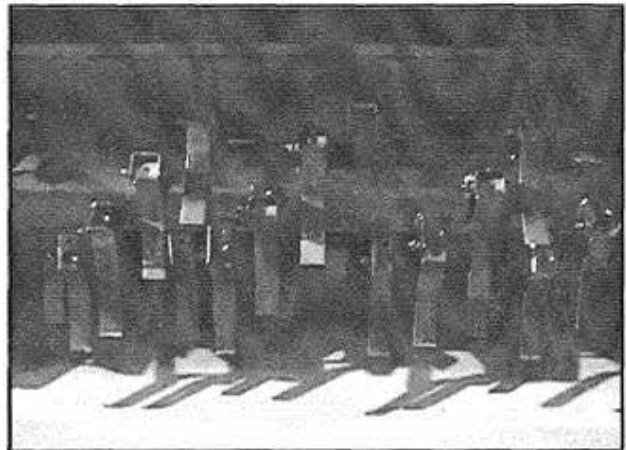

Figure 19. Cup Flails

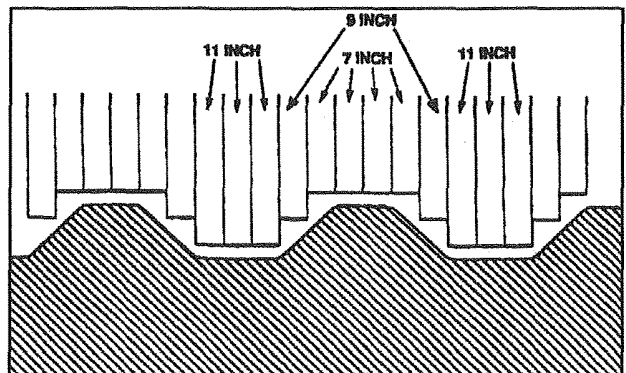

Figure 20. Optional Flail Contour

## Field Operation *Continued*

### Setting Outer Trailing Wheels

Normally, wheels are set to track in the row centers, between the raised seed beds. Tire position will determine flail height, but depth of furrow is also a factor in setting flail height. In some conditions the furrow between the seed beds is deeper on the ends, where irrigation waters enter the field. As furrows change depth, flail height will change.

To compensate for the depth change, move the trailing wheels against the side of the outer seed bed (see Figure 21). The wheels will then tend to climb up the side of the seed bed and prevent the flails from hitting the top of the bed.

Set the flail height after the wheels have been moved against the seed bed.

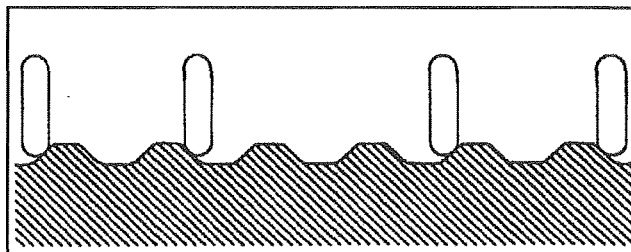
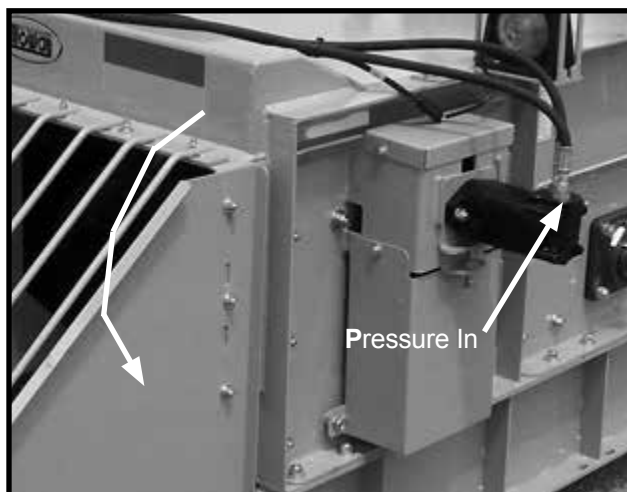

**Figure 21.** Wheel Position

Adjust wheel position by moving spindle to different hole location in spindle holder tube.

### Auger Operation

1. Check direction of Auger. Looking from Discharge side of machine, Auger spins in counter-clockwise direction.
2. Adjust Auger speed according to amount of trash in the field. If auger plugs or slows down, adjust Hydraulic Flow in tractor.
3. Auger speed RPM, between 350-450.
4. Auger needs to be running when windrow shredding..



**Figure 22.** Auger Pressure

## Field Operation *Continued*

### Starting the Tractor

1. Run tractor engine at low idle.
2. Engage Auger.
3. Slowly engage PTO control to start the shredder.
4. Slowly bring tractor engine to rated PTO speed. Never exceed rated speed.



### Stopping the Tractor

#### **WARNING**

■ Before dismounting power unit or performing any service or maintenance, follow these steps: disengage power to equipment, lower the 3-point hitch and all raised components to the ground, operate valve levers to release any hydraulic pressure, set parking brake, stop engine, remove key, and unfasten seat belt.

1. Slowly decrease engine speed to low idle.
2. Slowly disengage PTO clutch. The overrunning clutch will allow the shredder to freewheel down.
3. Disengage Hydraulics for Auger Motor.
4. Restart the unit only after the drums quit turning. The PTO will not need to be disengaged to lift the unit on the ends or while turning.

### Hazard Area

#### **WARNING**

■ Make certain all movement of equipment components has stopped before approaching for service.

Stay away from front, side, and rear of unit while it is running. Flails can pick up stones, sticks, wire, and other debris and throw it out with enough force to severely injure bystanders.

Keep out of shaded area shown in Figure 23.

Shut down unit and wait for moving parts to stop before approaching.

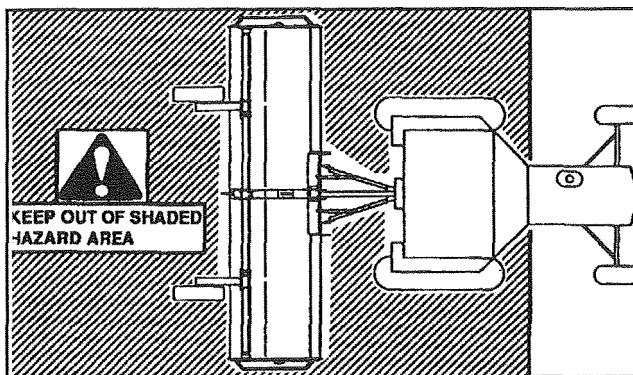

**Figure 23.** Hazard Area



## Field Operation *Continued*

### Ground Speed

Travel speed can vary between 3 and 8 mph (5 and 13 kmph) depending on the bulk of residue and terrain conditions. The operator is responsible for noting the condition of the work, setting the speed to obtain a quality shredding job, and maintaining control of the unit.

Speed may be increased if shredding quality is good.

Decrease speed if trash is left standing or if some is not picked up.

### Turning

#### 3-Point mounted units:

Always raise the unit slightly to lift rear wheels off the ground before turning. This will eliminate side loads on the wheel assembly, unless unit is equipped with castor wheels.

#### Pull-type units:

The front universal is equipped with a CV (Constant Velocity) joint to allow for turning. Although the CV joint allows for sharper turns than a regular drive-line, it does have some limitations. Refer to Figure 24.

CV joint angle should not exceed 80 degrees in either operating or standstill condition of the drive-line. Larger angles will damage the joint.

The angle should never exceed 35 degrees when the driveline is under full load.

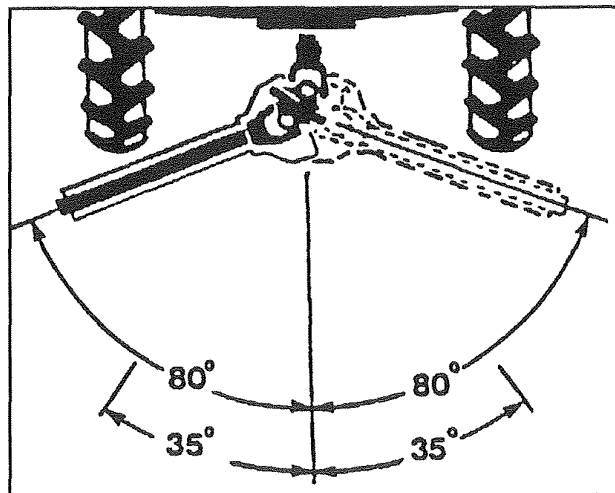

Figure 24. CV Joint Angles

### IMPORTANT

- Disengage PTO when making sharp turns.

## Additional Equipment

### Center Divider (Optional)

An optional center divider (Figure 27) can be mounted under the gearbox for pushing trash to the flails.



Figure 27. Optional Center Divider

### Front Shield Flap

All units are equipped front shield flaps (Figure 28) along the front of the frame. The shield flaps stop or deflect any trash, stones, or other debris picked up by the flails.

Be sure the shield flaps are in good condition for operation. Replace if damaged, torn, or missing.



Figure 28. Front Shield Flap

### End Guards & Skids

All units are equipped with end guard skids (Figure 29) to prevent flying debris or flail-to-ground contact.

**⚠ WARNING**

- Replace damaged or missing skids immediately.



Figure 29. Skids

## STORAGE

### **WARNING**

- **Block equipment securely for storage.**
- **Keep children and bystanders away from storage area.**

At the end of the season, the shredder should be thoroughly inspected and prepared for storage. Repair or replace any worn or damaged components to prevent unnecessary down time at the beginning of the next season.

To ensure a long, trouble-free life, prepare the unit for storage by carrying out the following procedure:

1. Clear the area of bystanders, especially children.
2. Thoroughly wash the unit, using a pressure washer to remove all dirt, mud, debris, and residue. Clear Auger Trough of debris.
3. Inspect the flails and rotors for damage or entangled material. Remove entangled material. Repair or replace damaged parts.
4. Inspect all hydraulic hoses, lines, couplers, and fittings. Tighten all loose fittings. Replace any hose that is cut, nicked, abraded, or separating from the crimped end of a fitting.
5. Change gearbox oil.
6. Lubricate all grease fittings. Make sure all grease cavities have been filled with grease to remove any water residue from from pressure washing.
7. Touch up all paint nicks and scratches to prevent rust.
8. Move to storage area. Select a dry area free of debris. Store in an area away from human activity.
9. Unhook from tractor (see Removing the Shredder from the Tractor, page 18).
10. Place safety stands or large blocks under the frame to take the load off the tires.

**NOTE:** Do not deflate tires.

11. If the unit cannot be placed indoors, cover with a waterproof tarpaulin and tie securely. Store away from human activity
12. Do not allow children to play on or around the stored unit.

# SERVICE & MAINTENANCE

## WARNING

■ Before dismounting power unit or performing any service or maintenance, follow these steps: disengage power to equipment, lower the 3-point hitch and all raised components to the ground, operate valve levers to release any hydraulic pressure, set parking brake, stop engine, remove key, and unfasten seat belt.

■ Before working underneath, read manual instructions, securely block up, and check stability. Secure blocking prevents equipment from dropping due to hydraulic leak down, hydraulic system failure, or mechanical component failure.

■ Keep all persons away from operator control area while performing adjustments, service, or maintenance.

■ Make sure shields and guards are properly installed and in good condition. Replace if damaged.

■ Do not handle blades with bare hands. Careless or improper handling may result in serious injury.

## CAUTION

■ Always wear relatively tight and belted clothing to avoid entanglement in moving parts. Wear sturdy, rough-soled work shoes and protective equipment for eyes, hair, hands, hearing, and head; and respirator or filter mask where appropriate.

■ Make certain all movement of equipment components has stopped before approaching for service.

## Lubricants

### 1. Grease

Use an SAE multi-purpose high temperature grease with extreme pressure (EP) performance. An SAE multi-purpose lithium-based grease is also acceptable.

### 2. Gearbox Oil

Use an SAE 85W90 gear oil for all operating conditions. Capacity: 3-1/2 U.S. quarts (2.25 liters)

### 3. Storing Lubricants

Your unit can operate at top efficiency only if clean lubricants are used. Use clean containers to handle all lubricants. Store them in an area protected from dust, moisture, and other contaminants.

## Greasing

**NOTE:** Use the Lubrication Service Record, page 36 to keep a record of all scheduled maintenance.

1. Use a hand-held grease gun for all greasing.
2. Wipe grease fitting with a clean cloth before greasing to avoid injecting dirt and grit.
3. Replace and repair broken fittings immediately.
4. If fittings will not take grease, remove and clean thoroughly. Also clean lubricant passageway. Replace fitting if necessary.

# Service & Maintenance *Continued*

## Lubrication Schedule

**NOTE:** Recommendations are based on normal operating conditions. Severe or unusual conditions may require more frequent lubrication or oil changes. Refer to Figure 30.

**Daily or every 8 hours of operation**

**PTO Driveline** Lubricate daily or every 8 hours of operation (every 4 hours if U-joints run at angles). See Figure 29 for lubrication points.

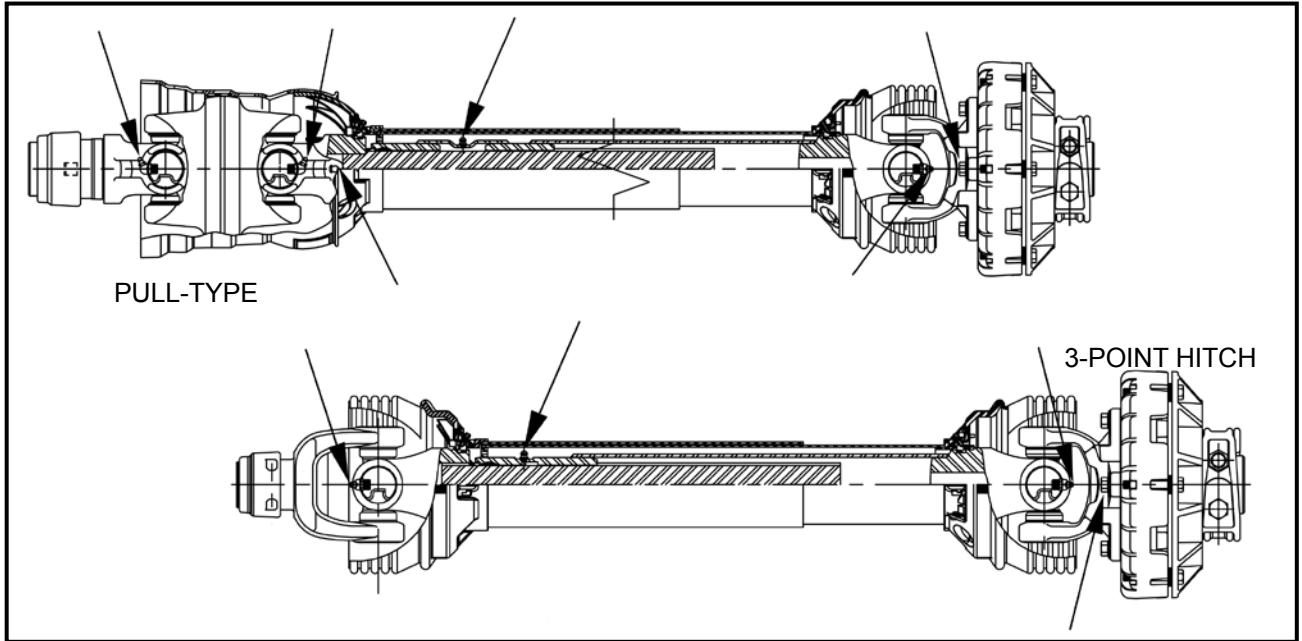

**Figure 29.** PTO Driveline Lubrication Points

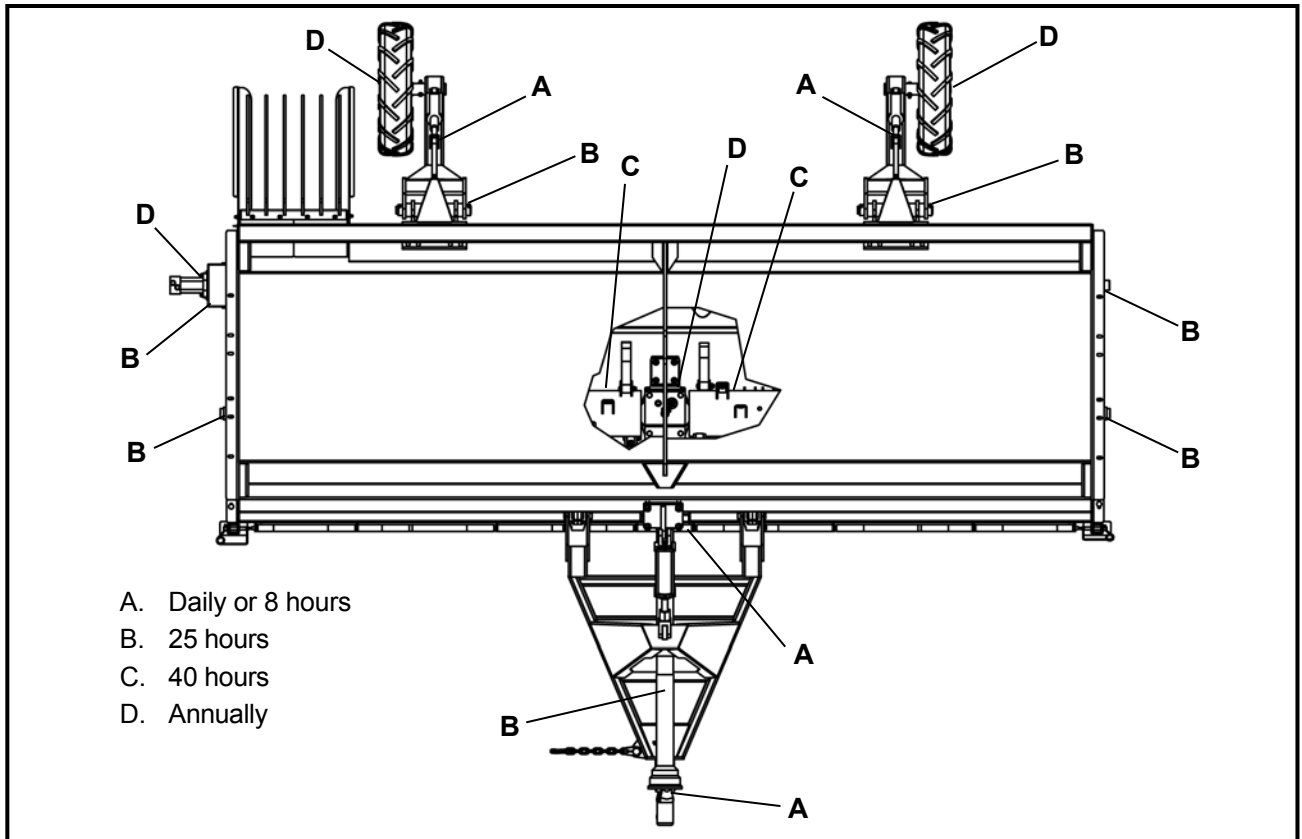

**Figure 30.** Lubrication Points

## Service & Maintenance *Continued*

### Lubrication Schedule *(Cont'd)*

#### Daily or every 8 hours of operation

1. Check gearbox daily or every 8 hours of operation. See Figure 31 for gearbox oil fill location

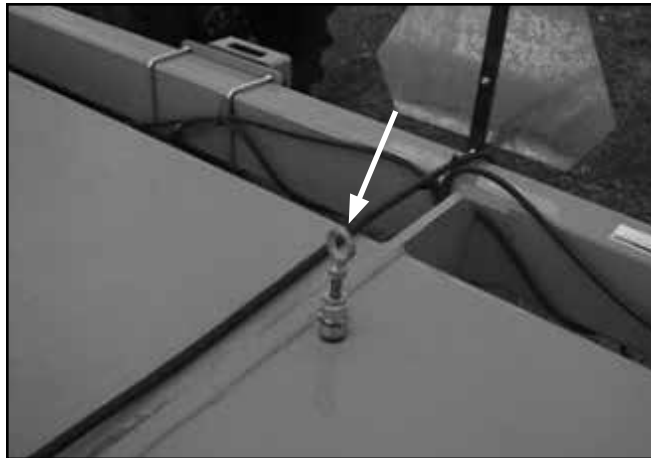

**Figure 31.** Gearbox Oil Fill Location

#### Every 25 hours of operation

1. Lubricate PTO driveline telescoping section (1 location, Position B, Figure 30).
2. Lubricate rotor end bearings. See Figure 32.



**Figure 32.** Auger and Rotor End Bearing Lubrication Points

3. Lubricate wheel strut pivots (3 to 5 locations). See Figure 33.



**Figure 33.** Wheel Strut Pivot Bearing Lubrication Points

## Service & Maintenance *Continued*

### Lubrication Schedule *(Cont'd)*

#### Every 40 hours of operation

1. Lubricate rotor drive hubs next to the couplers on underside of unit (2 locations). See Figure 34.
2. Grease the drive hubs with 10 to 20 shots. You may use extra grease only on drive hubs.

#### Annually

1. Change gearbox oil. Refill with SAE 85W90 gear oil. See Figure 34.

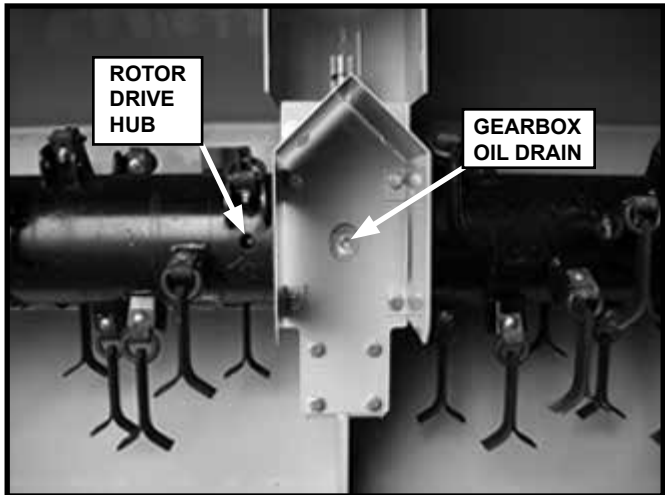

**Figure 34.** Rotor Drive Hub Lubrication Points & Gearbox Oil Drain Location

2. Repack wheel bearings. See Figure 35.



**Figure 35.** Wheel Bearings

3. Lubricate ratchets as necessary (2 locations each ratchet). See Figure 36.

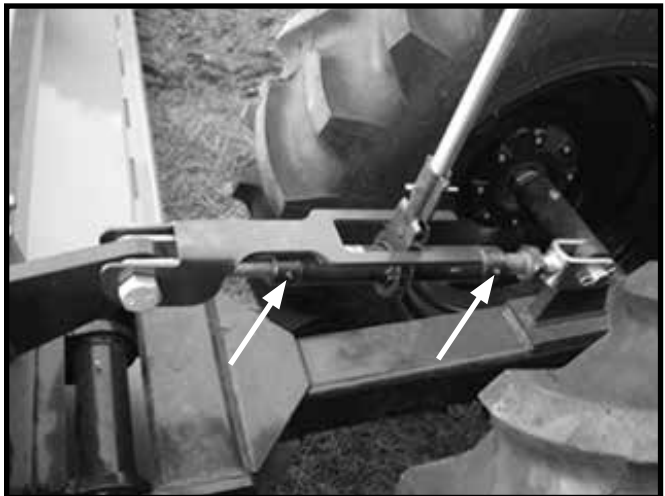

**Figure 36.** Ratchet Lubrication Points

# Service & Maintenance *Continued*

## Lubrication Service Record

✓ CHECK

C CHANGE

**NOTE:** See page 33 through page 35 for details.  
Copy this page to continue service record.

L LUBRICATE

R REPACK

<b>HOURS OF SERVICE</b>																			
<b>SERVICED BY</b>																			
<b>10 Hours or daily</b>																			
L PTO Driveline (8)																			
L PTO Driveline telescope section																			
L U-Joint(1)																			
L Overrunning clutch (1)																			
✓ Gearbox oil level																			
<b>25 Hours</b>																			
L Rotor end bearings																			
L Wheel mounting tube bearings																			
<b>40 Hours</b>																			
L Rotor inner bearings (2)																			
<b>Annually</b>																			
C Gearbox oil																			
R Wheel bearings																			



## Service & Maintenance *Continued*

### Acceptable Oil Leakage from Gearbox

Not all gearbox oil leakage or seepage is serious.

#### IMPORTANT

■ Gearbox oil seepage is acceptable if

1. Oil covers less than a 3-inch diameter area around the shaft seal area (see Figure 37).
2. Oil covers 4 inches around the vent or drain plugs (see Figure 37).

if oil covers an area larger than that described in 1 & 2, do the following:

- a. Check gearbox oil level. If it is low, fill to proper level.
- b. Clean oily area of gearbox. Use a degreaser to remove all oil.
- c. Closely monitor gearbox for 10 hours of operation. Check oil level often.
- d. If after 10 hours of operation oil covers less than area described in 1 & 2 above, leakage is acceptable.

**NOTE:** Warranty only covers oil leakage that is in excess of above limits.

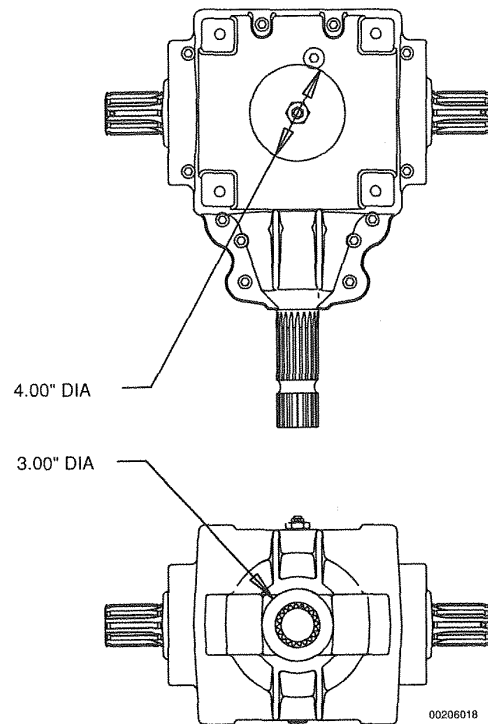

Figure 37. Acceptable Oil Leakage

### Changing Gearbox Oil

Although gearbox oil never wears out, dust, dirt, and moisture can enter through the breather during operation. These contaminants must be removed once a year to ensure a long life for working components. In very dusty or dirty conditions, change the oil twice a year.

1. Clear area of bystanders, especially children.
2. Shut off tractor, place all controls in neutral, set parking brake, remove key, and wait for all moving parts to stop.
3. Raise the unit to provide access to underside. Place safety stands or large blocks under frame.
4. Disconnect PTO driveline and hydraulic lines.
5. Place a pan under drain plug. Remove drain plug and dip stick plug (see Figure 38).
6. Allow gearbox to drain for 10 minutes.

**NOTE:** To remove the most contaminants, drain oil when gearbox is hot.

7. Re-install and tighten drain plug.
8. Dispose of used oil in an approved container.
9. Add SAE 85W90 gear oil through the dip stick cover. Use the dip stick to check the oil level (Figure 39) and add oil accordingly.
10. Re-install and tighten fill plug.
11. Reconnect PTO driveline and hydraulic lines.
12. Remove blocks or safety stands.



Figure 38. Drain Plug (underside of unit)



Figure 39. Dipstick Location

## Service & Maintenance *Continued*

### Setting Ratchets

Mechanical ratchets provide height setting for the unit. To set ratchets, follow this procedure:

1. Clear the area of bystanders, especially children.
2. Turn the turnbuckle to achieve the desired ratchet length (see Figure).
3. Repeat Step 2 with other ratchets.



### Wheel Spacing

The rear wheels can be adjusted for alignment with crop rows.

1. Clear the area of bystanders, especially children.
2. Shut off tractor, place all controls in neutral, set parking brake, remove key, and wait for all moving parts to stop.
3. Use a jack with sufficient capacity to lift the frame.
4. To determine wheel spacing, measure from the center line of the unit. Mark positions on the frame.
5. Lift frame until wheels have cleared the ground.
6. Place safety stands or large blocks under the frame.
7. Loosen mounting bolts on one wheel assembly.
8. Slide assembly along the frame tube to new position (see Figure 40).
9. Tighten mounting bolts to specified torque level.
10. Remove safety stands or blocks.
11. Lower and remove jack.
12. Repeat with other wheel assembly.



**Figure 40.** Positioning Wheel Assembly

### Replacing Flails

#### **WARNING**

- **Do not handle blades with bare hands. Careless or improper handling may result in serious injury.**

The flails swing on bushings, which are sandwiched between clips and mounted to the flail tube with bolts. Regularly inspect the flails for wear or damage. To replace worn or damaged flails, follow this procedure:

1. Clear the area of bystanders, especially children.
2. Shut off tractor, place all controls in neutral, set parking brake, remove key, and wait for all moving parts to stop.
3. Disconnect driveline and hydraulic lines from the tractor.
4. Place safety stands or large blocks under the frame.
5. Loosen and remove the mounting bolt on the worn flail and its opposite on the other side of the rotor. Discard worn flails and their mounting hardware.
6. Replace with new flails and and mounting hardware (see Figure 41).
7. Tighten flail mounting bolt to its specified torque.

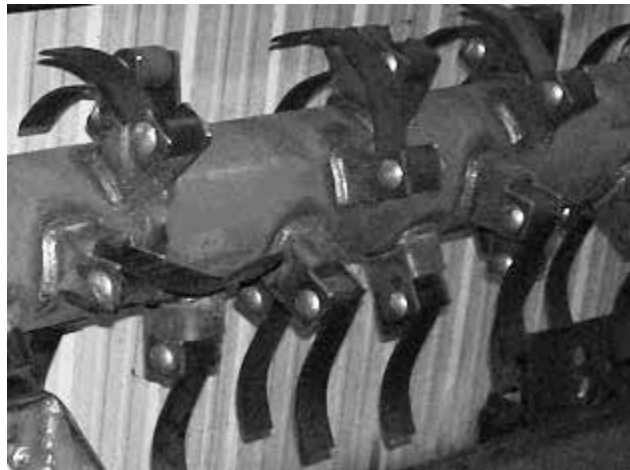

**Figure 41.** Flail Replacement

#### **IMPORTANT**

- **To maintain rotor balance, always replace opposite pairs of flails and mounting hardware.**
8. Replace additional worn flails following Step 5 and Step 6.
  9. Remove safety stands or blocks from under frame.
  10. Lower unit and remove jack.
  11. Attach driveline and hydraulic line to tractor.

### Replacing Rubber Shield Flaps

Rubber shield flaps on the front of the unit deflect or prevent stones or debris from being ejected when operating unit. Replace if damaged or missing to provide a safe work environment. To replace, follow this procedure:

1. Clear the area of bystanders, especially children.
2. Lower the unit to the ground, place all controls in neutral, shut off engine, set park brake, remove key, and wait for all moving parts to stop before dismounting.

**NOTE:** For 3-point hitch units, unhook to gain access to center flaps.

3. Remove the cotter pin from the end of the flap rod and pull rod until the flap comes off.
4. Install new shield flap.
5. Push rod through flaps and re-install cotter pin.



**Figure 42.** Front Rubber Shield Flaps

**NOTE:** Use only genuine Alloway parts when replacing flaps.

### Servicing Rotors

The shredder rotors are dynamically balanced from the factory and should be maintained to keep them in balance and to prevent excessive wear on drive components.

#### IMPORTANT

■ Any vibration caused by missing knives or worn drive components can cause excessive damage to the shredder. Vibration is also transmitted through the PTO shaft to the tractor and will damage tractor

When servicing rotors, follow this procedure:

1. Clear the area of bystanders, especially children.
2. Shut off tractor, place all controls in neutral, set park brake, remove key, and wait for all moving parts to stop.
3. Disconnect unit from the tractor.
4. Remove the PTO driveline from the unit.
5. Remove wheel arms.
6. Use a hoist, crane, or a frame of sufficient capacity to raise the front of the unit and allow back of unit to rest on a solid surface.

#### CAUTION

■ Use a suitable lifting device of sufficient capacity. Use adequate personnel to handle heavy components.

7. Leave lifting device attached while working on rotors to prevent tipping.
8. Remove knives. Wear heavy canvas or leather gloves to protect your hands.

#### Removing components:

1. With unit raised (Step 6), support each end of rotor with crane or hoist.
2. Remove bearing locking collar (see Figure 44).
3. Remove 8 bolts holding bearing plate to body assembly.
4. Slide rotor out to disengage from the Windrow hub.
5. Check drive hubs for wear and replace if necessary. If O-ring grease seal is cut or worn, replace it.
6. Remove gearbox if damaged.

#### Replacing components:

Place new stud bolts into gearbox, using Loctite® No. 271 or equivalent.

7. Remount gearbox.
8. Insert outer shaft through end plate hole.
9. Install drive hub to gearbox output shaft. Thoroughly clean both halves of the drive couplers and apply new grease to all gear teeth.

**NOTE:** When replacing flail tube, you will have to remove the grease zerk to allow air to purge from the coupler assembly. Then replace grease fitting and follow lubrication schedule.

10. Install bearing plate bolts and tighten to specified torque.

#### IMPORTANT

■ To keep drive hub bolts from loosening, use Loctite No. 271 or equivalent and special Hi-Collar lock washers.

11. Re-install locking collar and tighten in the direction of rotation (see Figure 44).

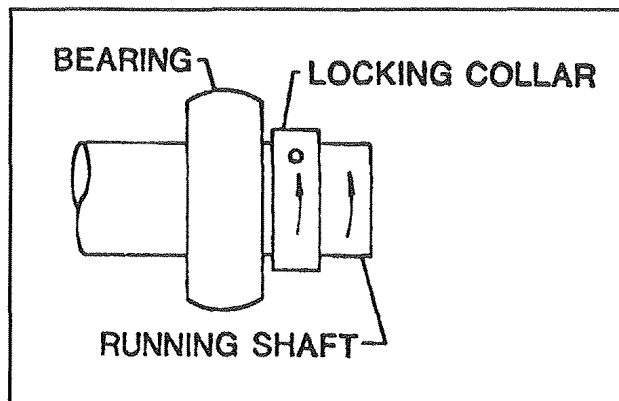

Figure 44. Locking Collar

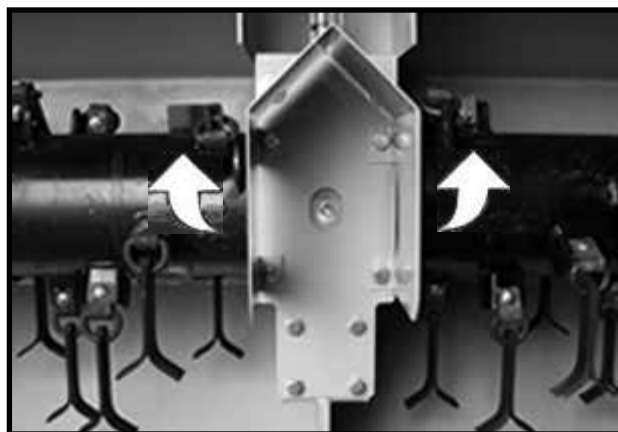

Figure 45. Rotor Direction of Rotation

a. Loctite is a registered trademark of the Loctite Corporation.

## Service & Maintenance *Continued*

### Replacing Stub Shaft

1. Remove rotor (see Servicing Rotors, page 41).
2. Remove three 1/2 x 2-1/2 hex bolts in taper lock hub and re-install bolts in three threaded holes (see Figure 46).
3. Tighten bolts evenly to release taper lock hub from stub shaft. **NOTE:** You may have to give a sharp blow directly to each bolt head to help the hub disengage.
4. Unscrew stub shaft from the rotor tube.
5. Install new stub shaft, reversing Steps 1-3.

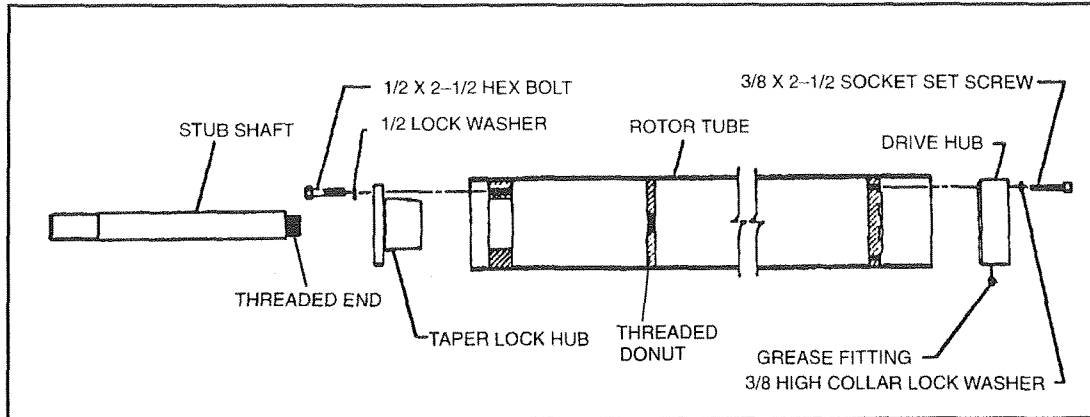

Figure 46. Stub Shaft Assembly

### Servicing Weasler Modular Friction Clutch

#### Tools Required

- 3/4" Socket wrench
- 8" Minimum C-clamps (2)
- 1/4" Hex Allen wrench
- Regular screwdriver or punch
- Duct tape or locking pliers with 3" throat minimum
- Hammer
- 1/2" sq. to 1"sq. barx 9"
- Scale or Vernier

#### Breaking in the Clutch (Run In)

**NOTE:** All new clutches must be broken in (Run in) and any clutch that has not been used for approximately 60 days.

1. Shut off tractor and disengage PTO.
2. Disconnect driveline from the tractor PTO shaft.
3. Loosen the bolts on the outside diameter of the clutch until all bolts are just loose, then tighten all bolts 1/2 turn.
4. Attach the shredder to the tractor and the drive-line to the tractor PTO. Stand clear of the unit.
5. Start tractor. Engage PTO clutch and run for a few seconds or until clutch visibly smokes.
6. Disengage PTO. Shut off tractor. Disconnect driveline from the tractor.
7. Tighten all bolts on the outside diameter of the clutch until the compression plate is tight against the housing.
8. Grease the fitting on the yoke, using Shell Super Duty or an equivalent lithium grease.
9. For an integral overrunning clutch, make sure clutch turns freely in one direction.

### Servicing Weasler Modular Friction Clutch (*Cont'd*)

#### Removing the Driveline

1. Shut off tractor and disengage PTO.
2. Disconnect driveline from PTO shaft.
3. Remove the clamp bolts attaching the clutch to the shredder's input shaft.
4. **NOTE:** The shaft is heavy. Grasp the clutch firmly with both hands and slide off the input shaft.

#### Rebuilding Friction Pack

##### Disassembly

1. Position clutch and universal joint assembly on a bench so that end is accessible.
2. Remove the long bolts on the outside of the housing that hold the friction pack together.
3. Remove the plate(s) and all internal components. Leave the yoke/hub intact.
4. Discard friction discs.
5. If rebuilding the overrunning clutch, refer to Rebuilding Overrunning Clutch, page 45, beginning with Step 2.

##### Inspection

6. Inspect the steel and iron parts for wear, warping, or cracks, and replace if necessary.
7. Inspect the yoke/hub for looseness. If there is more than .03 end play, replace.
8. Clean any rust or dust from the plate surfaces with a wire brush or steel wool.

##### Assembly

9. Into housing place one new friction disc, then separator plate, then second friction disc.
10. Add the pressure plate so that the flat surface rests on the friction disc. **NOTE:** The tangs on the plate must fall into the reliefs in the housing.
11. Add the disc spring so that its inside diameter contacts the fins of the pressure plate.
12. Assemble the compression plate and all the long bolts. Make sure all nuts rest in their pockets.
13. Tighten all long bolts to 30 lbs.-ft.

#### Rebuilding Overrunning Clutch

##### Disassembly

1. Remove the four bolts that secure the friction pack. Remove the friction pack.

2. Using screwdriver and pliers, remove the retaining ring that holds the overrunning clutch together.
3. Slide the collar and washer off the clutch hub, noting the orientation of the collar for reinsertion.
4. Remove and discard the keys and leaf springs.

##### Inspection

5. Inspect the steel parts for wear and replace if necessary.
6. Inspect the yoke/hub for looseness. If there is more than .03 end play, replace.
7. Using screwdriver, scrape any hardened grease from the overrunning key pockets.

##### Assembly

8. Using Shell Super Duty grease or equivalent, inject one grease gun pump into each key pocket. Evenly wipe two more pumps over the overrunning surface.
9. Press a new leaf spring into each pocket. The ends should touch the bottom of the pockets.
10. Add new keys. With one hand, hold the two keys in the pockets.
11. Slide the collar onto the hub, orienting collar correctly.
12. Add washer.
13. Install retaining ring.
14. Make sure clutch spins freely and only in correct direction.
15. Reassemble friction pack.

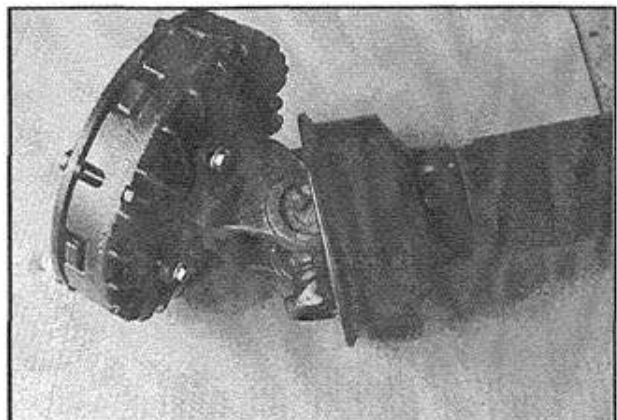

**Figure 47. Weasler Modular Friction Clutch Mounting Clutch onto Shredder**

1. Mount and bolt the clutch hub onto the shredder input shaft. Make sure shaft and clutch grooves line up.
2. Re-install any shielding that was moved or removed.
3. Run the clutch before using. Refer to Breaking in the Clutch (Run In), page 44.

# TROUBLE SHOOTING

The Alloway Windrow Shredder uses swinging flails to pick up and shred crop residue left in the field. It is a simple and reliable system that requires minimal maintenance.

The following table lists problems, causes, and

solutions that you may encounter. If you encounter a problem that is difficult to solve even after reading through this table, please call your local Alloway dealer. When calling, please have this manual and your unit's serial number ready.

PROBLEM	CAUSE	SOLUTION
Shredder doesn't track	Poor wheel spacing	Set wheels in center of crop rows
	3 Point not set	Set 3-point hitch in non-sway position
	Shredder not level	Level shredder (see Set Operating Height, page 23)
Shredder doesn't follow ground contour	Irrigation furrows not even	Set wheels against seed bed (see Setting Outer Trailing Wheels, page 26)
	3 Point not set	Set 3 point in float position
	Shredder too high	Set shredder closer to ground
Shredder vibrates	Irrigation furrows not even	Set wheels against seed bed
	Driveline doesn't telescope	Remove, disassemble, and clean telescoping joint
	Rotor out of balance	Replace damaged or broken flails and flails 180 degree opposite
Debris being thrown out from under shredder		Check for missing balance weights or rebalance
	Shredder set too low	Raise shredder
	Knives excessively worn	Replace knives
Crop residue left	Rubber shields missing	Replace flaps immediately
	Travelling too fast	Slow travel speed
	Shredder too high	Lower shredder
	Improper flails	Change flails
Windrowing stops	Crop residue strip left in shredder center	Add center cutter or divider
	Plugged Auger	Open doors, Unplug
Windrow not large enough	Auger Speed too Slow	Adjust Hydraulic Flow in tractor

# ASSEMBLY

## WARNING

- Do not allow bystanders in the area when operating, attaching, removing, assembling, or servicing equipment.
- Do not handle blades with bare hands. Careless or improper handling may result in serious injury.

## CAUTION

- Always wear relatively tight and belted clothing to avoid entanglement in moving parts. Wear sturdy, rough-soled work shoes and protective equipment for eyes, hair, hands, hearing, and head; and respirator or filter mask where appropriate.

## WARNING

- Keep hands and body away from pressurized lines. Use paper or cardboard, not hands or other body parts to check for leaks. Wear safety goggles. Hydraulic fluid under pressure can easily penetrate skin and will cause serious injury or death.
- Make sure that all operating and service personnel know that if hydraulic fluid penetrates skin, it must be surgically removed as soon as possible by a doctor familiar with this form of injury or gangrene, serious injury, or death will result. **CONTACT A PHYSICIAN IMMEDIATELY IF FLUID ENTERS SKIN OR EYES. DO NOT DELAY.**
- Check that all hardware is properly installed. Always tighten to torque chart specifications unless instructed otherwise in this manual.



# CHECK LISTS

## Assembly *Continued*

<b>PRE-DELIVERY CHECK LIST</b> (DEALER'S RESPONSIBILITY)	<b>DELIVERY CHECK LIST</b> (DEALER'S RESPONSIBILITY)
<p>Inspect the equipment thoroughly after assembly to ensure it is set up properly before delivering it to the customer.</p> <p>The following check lists are a reminder of points to inspect. Check off each item as it is found satisfactory or after proper adjustment is made.</p> <p><input type="checkbox"/> Check that all safety decals are installed and in good condition. Replace if damaged.</p> <p><input type="checkbox"/> Check that shields and guards are properly installed and in good condition. Replace if damaged.</p> <p><input type="checkbox"/> Check that PTO shaft is properly installed.</p> <p><input type="checkbox"/> Properly attach implement to tractor and make all necessary adjustments.</p> <p><input type="checkbox"/> Check all bolts to be sure they are tight.</p> <p><input type="checkbox"/> Check wheel bolts for proper torque.</p> <p><input type="checkbox"/> Check that all cotter pins and safety pins are properly installed. Replace if damaged.</p> <p><input type="checkbox"/> Check and grease all lubrication points as identified in "Service, lubrication information."</p> <p><input type="checkbox"/> Check the level of gearbox fluids before delivery. Service, if required, as specified in the "Service, lubrication information."</p> <p><input type="checkbox"/> Check that tractor hydraulic reservoir has been serviced and that hydraulic system and all functions have been operated through full cylinder stroke to purge air from system.</p> <p><input type="checkbox"/> After pressurizing and operating all Shredder functions, stop tractor and make sure there are no leaks in the hydraulic system. Follow all safety rules when checking for leaks.</p>	<p><input type="checkbox"/> Show customer how to make adjustments and select proper PTO speed.</p> <p><input type="checkbox"/> Instruct customer how to lubricate and explain importance of lubrication.</p> <p><input type="checkbox"/> Point out the safety decals. Explain their meaning and the need to keep them in place and in good condition. Emphasize the increased safety hazards when instructions are not followed.</p> <p><input type="checkbox"/> Present Operator's Manual and request that customer and all operators read it before operating equipment. Point out the manual safety rules, explain their meanings and emphasize the increased safety hazards that exist when safety rules are not followed.</p> <p><input type="checkbox"/> Show customer how to make sure driveline is properly installed and that spring-activated locking pin or collar slides freely and is seated in groove on tractor PTO shaft.</p> <p><input type="checkbox"/> Show customer the safe, proper procedures to be used when mounting, dismounting, and storing equipment.</p> <p><input type="checkbox"/> Explain to customer that when equipment is transported on a road or highway, safety devices should be used to give adequate warning to operators of other vehicles.</p> <p><input type="checkbox"/> Explain to customer that when equipment is transported on a road or highway, a Slow Moving Vehicle (SMV) sign should be used to provide adequate warning to operators of other vehicles.</p> <p><input type="checkbox"/> Explain to customer that when towing on a public road to comply with all state and local lighting/ marking laws and to use a safety tow chain.</p> <p><input type="checkbox"/> Make customer aware of optional equipment available so that customer can make proper choices as required.</p> <p><input type="checkbox"/> Point out all guards and shields. Explain their importance and the safety hazards that exist when not kept in place and in good condition.</p>

## Assembly Continued

### WARNING

■ Do not allow bystanders in the area when operating, attaching, removing, assembling, or servicing equipment.

### CAUTION

■ Always wear relatively tight and belted clothing to avoid entanglement in moving parts. Wear sturdy, rough-soled work shoes and protective equipment for eyes, hair, hands, hearing, and head; and respirator or filter mask where appropriate.

■ Use a suitable lifting device of sufficient capacity. Use adequate personnel to handle heavy components.

1. Open the crate and cartons containing the attaching components and mounting hardware.
2. Use the packing list to check that all parts have been shipped.

3. Raise the rear of the unit.
4. Place safety stands or large blocks under the frame.
5. Measure the wheel spacing from the center of the unit. Mark the frame.
6. Install the wheel assembly to the mounting tube (Figure 51). **If equipped with caster wheels, verify that there is enough clearance for casters to rotate without hitting each other.** Failure to do so will result in tire damage. Offset struts may be required (see Wheel Assembly parts page 64).
7. Tighten mounting bolts to their specified torque.



Figure 51. Wheel Assembly Installed

### 3-Point Units:

8. Fasten floating top mast (1) to shredder, using four 1 x 6" hex bolts and top lock nuts as shown in Figure 52. Be sure mast is free to slide forward.
9. Attach one upper 3-point 1 x 5" bolt, bushing, lock washer, and hex nut (2).
  - a. **Category II:** Fasten components in the lower hole in floating top mast.
  - b. **Category III:** Fasten components in the upper hole in floating top mast.
10. Fasten lower 3-point.
11. Fasten hoses and Quick coupler to hoses that run to Hydraulic Motor.

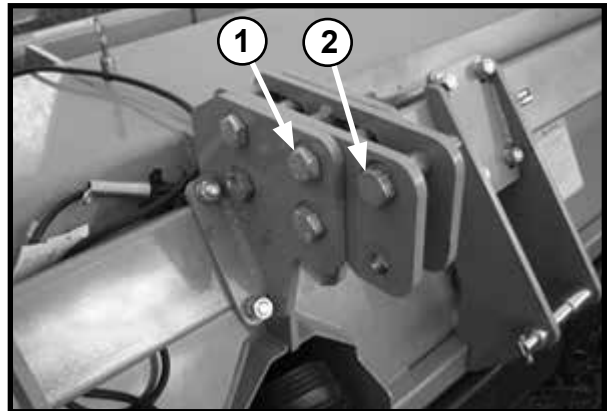

Figure 52. Floating Top Mast Installed

### All Units

3. Install PTO driveline by sliding the yoke with the slip clutch over the input shaft (Figure 53).
4. Tighten mounting bolts to its specified torque.
5. Install front parking stands, using pin.



Figure 53. Gearbox Input Shaft

## Assembly Continued

### Install Pull-Type Hitch (Pull-type units only)

1. Mount hitch to frame using pins and bolts.
2. Install ratchet. Be sure to install retaining pins.
3. Attach Ear Plate to upper tube using U-Bolts and hardware provided.
4. Attach clevis to hitch, using 1-1/4" pin and 3/8 x 3-1/2" cotter pins.
5. Attach tow chain to hitch. See Figure 56 for completed assembly.
6. Fasten hose and Quick coupler. Attach to hoses that run to Hydraulic Motor.



Figure 54. Pull-type Hitch Installed

### Install Manual Storage Tube

1. Mount the tube clamp to the shredder side sheet, using two 1/4" self-tapping screws. Mounting holes are located above the bearing plate (see Figure 55).
2. Place the tube in the clamp with the cap facing forward.

**NOTE:** Keep the Owner's Manual with the shredder at all times.



Figure 55. Manual Storage Tube Assembly

## Assembly Continued

### Safety Light Kit Installation (Non-End Tow)

1. Remove all components from shipping carton. Make sure that all required hardware is included.
2. Attach dual safety lights (Figure 59) to their bases using 1/4 NC x 1" hex bolts, washers and nuts provided. Make sure that light lenses are in the correct position in relation to direction of equipment travel: amber lenses on the outside, red lenses on the inside facing rear of shredder.
3. Plug ends of wiring harness into corresponding plugs of the light units (Note: left side of wishbone harness is labeled "Left").
4. Run wiring harness along top of shredder and secure with enclosed adhesive-backed clamps (5) approximately every two feet.
5. Connect 7-pin connector of wiring harness to tractor and test all light functions before actual use.



**Figure 58.** Safety Light Kit Installed  
(Non-End Tow)

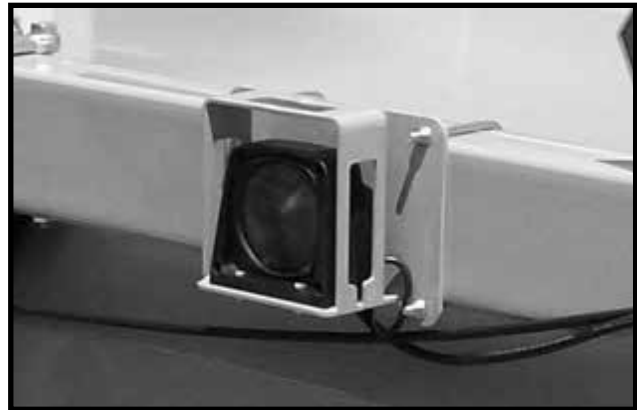

**WINDROW SHREDDER**

FRAME COMPONENTS.....	44-47
FLAIL TUBE COMPONENTS .....	48
AUGER DRIVE COMPONENTS.....	49
3-POINT HITCH COMPONENTS.....	50
PULL TYPE HITCH COMPONENTS .....	51
FRONT CASTER WHEEL COMPONENTS .....	52-53
REAR CASTER WHEEL COMPONENTS.....	54-55
RIGID STRUT - DUAL ( LARGE WHEELS).....	56-57
RIGID STRUT - DUAL (SMALL WHEELS) .....	58-59
HYDRAULIC PLUMBING STRUT COMPONENTS.....	60
HYDRAULIC PLUMBING AUGER COMPONENTS .....	61
HYDRAULIC PLUMBING CASTER COMPONENTS .....	62-63
END TRANSPORT STRUT COMPONENTS .....	64-65
END TRANSPORT FRAME COMPONENTS .....	66-67
LIGHT KIT COMPONENTS.....	68
HUB AND SPINDLE COMPONENTENTS.....	69
WEASLER PULL-TYPE PTO SHAFT WITH TORQ MASTER CLUTCH.....	70
WEASLER 2-POINT & 3-POINT PTO SHAFT WITH TORQ MASTER CLUTCH .....	71
WEASLER TORQ MASTER CLUTCH COMPONENTS .....	72-73
CENTER DRIVE GEARBOX COMPONENTS .....	74
BOLT TORQUE & SIZE CHARTS .....	76-77
2008 & OLDER MODEL COMPONENTS.....	78-87

# WINDROW SHREDDER FRAME COMPONENTS

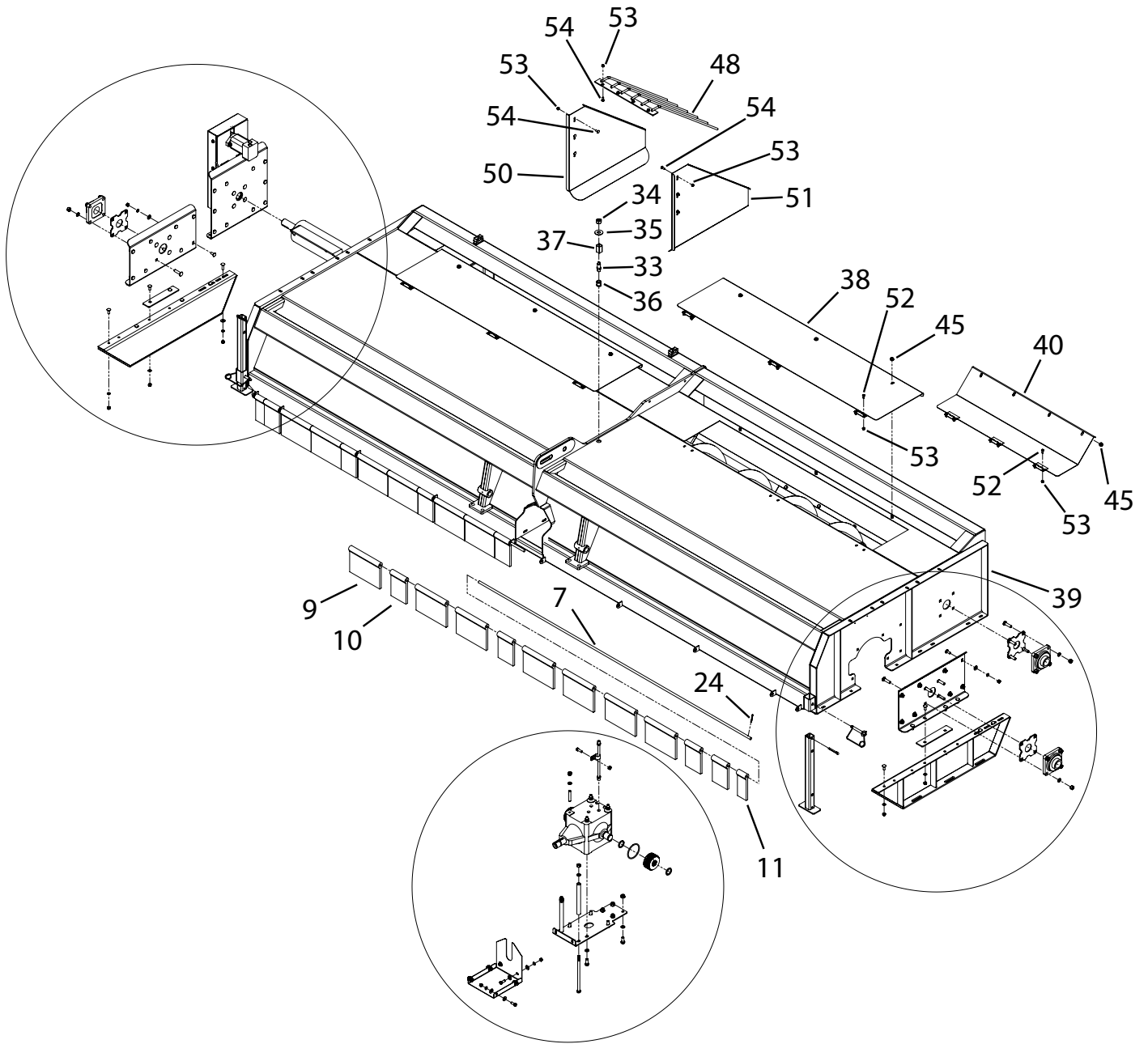

SEE NEXT PAGE FOR DETAILED VIEWS

## WINDROW SHREDDER FRAME COMPONENTS

ITEM NO.	PART NUMBER	DESCRIPTION	QTY.
1	507-3-0023	BEARING MOUNTING PLATE	2
2	507-3-0120	BOTTOM GEARBOX PLATE	1
3	507-3-0046	SPACER PLATE - SKID	2
4	507-2-0018	SKID PLATE WELD - LH	1
5	507-2-0019	SKID PLATE WELD - RH	1
6	507-3-0121	CLUTCH SHIELD	1
7	507-3-0605	FLAP ROD - 13'	2
	507-3-0372	FLAP ROD - 15'	
	507-3-0538	FLAP ROD - 18'	
	507-3-0394	FLAP ROD - 20'	
	507-3-0128	FLAP ROD - 22'	
8	507-2-0021	PARKING STAND WELD	2
9	505-3-1089	FLAP SHIELD 12"	
10	505-3-1097	FLAP SHIELD 6"	
11	505-3-0868	FLAP SHIELD 3-1/2"	
12	901-01386	BEARING - 2.19 4-BOLT ECC. LOCK	3
13	903-15575	G-BOX - SUPERIOR MODEL R800 (1:1 GEAR RATIO)	1
14	900-11015	WASHER, LOCK 5/8	31
15	900-01341	BOLT, HEX HEAD 5/8 NC X 1-1/2, GR5 ZP	12
16	900-06145	NUT, WHIZ 5/8 NC	4
17	900-11013	WASHER, LOCK 1/2	50
18	900-11035	WASHER, FLAT 1/2	42
19	900-06009	NUT, HEX HEAD 1/2 NC	48
20	900-01223	BOLT, HEX HEAD 1/2 NC X 1-1/2, GR5 ZP	6
21	900-01750	BOLT, CARRIAGE 1/2 NC X 1 1/4, GR5 ZP	40
22	900-42054	PIN, LOCK UP	2
23	900-06013	NUT, HEX HEAD 5/8 NC	19
24	900-23043	PIN, COTTER 3/16 X 1 1/2	2
25	900-39030	RETAINING RING 600 SERIES	4
26	500-3-0338	COUPLER	2
27	901-09126	O-RING, FLAIL COUPLER	2
28	507-2-0296	AUGER WELD - 13' WINDROW - RH DISCHARGE	1
	507-2-0311	AUGER WELD - 13' WINDROW - LH DISCHARGE	
	507-2-0322	AUGER WELD - 15' WINDROW - CENTER DISCHARGE	
	507-2-0323	AUGER WELD - 18' WINDROW - RH DISCHARGE	
	507-2-0282	AUGER WELD - 18' WINDROW - LH DISCHARGE	
	507-2-0260	AUGER WELD - 20' WINDROW - CENTER DISCHARGE	
	507-2-0157	AUGER WELD - 22' WINDROW - CENTER DISCHARGE	
29	507-3-0242	UHMW SEAL PLATE - END BEARING	3
30	900-23084	PIN, COTTER, 3/8 X 3-1/2	2
31	507-3-0630	STUD - GEARBOX	4
32	905-19224	BRAIDED DIPSTICK TUBE	1
33	507-3-0268	DIPSTICK SUPPORT BRACKET	1
34	900-06017	NUT, HEX HEAD 7/8 NC	1
35	900-11039	WASHER, FLAT 7/8	1
36	905-01189	COUPLING 1/2 NPT	1
37	507-3-0342	SPACER - DIPSTICK	1
38	507-2-0281	DOOR WELD - UPPER TROUGH	2

# WINDROW SHREDDER FRAME COMPONENTS

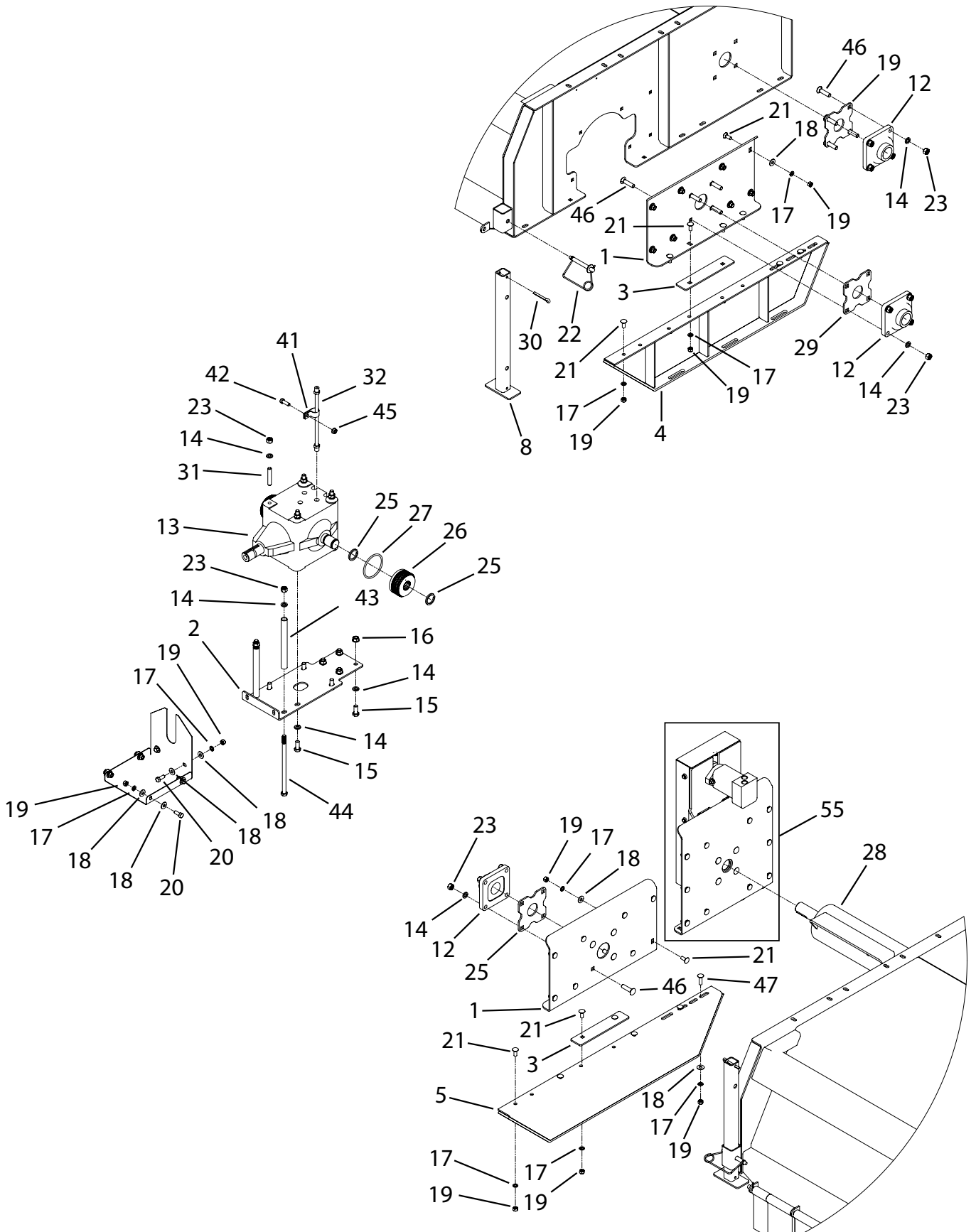



## WINDROW SHREDDER FRAME COMPONENTS

ITEM NO.	PART NUMBER	DESCRIPTION	QTY.
39	507-2-0318	BODY WELD - 13' WINDROW - GEAR DRIVE - LH	1
	507-2-0295	BODY WELD - 13' WINDROW - GEAR DRIVE - RH	
	507-2-0319	BODY WELD - 15' WINDROW - GEAR DRIVE - CENTER	
	507-2-0320	BODY WELD - 18' WINDROW - GEAR DRIVE - LH	
	507-2-0279	BODY WELD - 18' WINDROW - GEAR DRIVE - RH	
	507-2-0258	BODY WELD - 20' WINDROW - GEAR DRIVE - CENTER	
	507-2-0149	BODY WELD - 22' WINDROW - GEAR DRIVE - CENTER	
40	507-2-0290	DOOR WELD - BOTTOM TROUGH	
41	900-31045	HOSE HOLDER - 1-1/4"	1
42	900-01225	BOLT, HEX HEAD 1/2 NC X 1-1/2, GR 5 ZP	1
43	507-3-0224	SPACER TUBE - GEARBOX	2
44	900-01393	BOLT, HEX HEAD 5/8 NC X 12, GR5 ZP	2
45	900-06143	NUT, SPIRALOCK 1/2 NC	11
46	900-01788	BOLT, CARRIAGE 5/8 NC X 2-1/2, GR5 ZP	17
47	900-01752	BOLT, CARRIAGE 1/2 NC X 1 3/4, GR5 ZP	2
48	507-2-0193	DISCHARGE SPOUT - END DISCHARGE	1
	507-2-0259	DISCHARGE SPOUT - CENTER DISCHARGE	1
50	507-3-0356	SIDE PLATE - DISCHARGE CHUTE RH	1
51	507-3-0357	SIDE PLATE - DISCHARGE CHUTE LH	1
52	900-01105	BOLT, HEX HEAD 3/8 NC X 3/4, GR5 ZP	18
53	900-06139	NUT, WHIZ 3/8 NC	28
54	900-01695	BOLT, CARRIAGE 3/8 NC X 1, GR5 ZP	10
55		AUGER DRIVE COMPONENTS (SEE PAGE 49)	

## FLAIL TUBE COMPONENTS

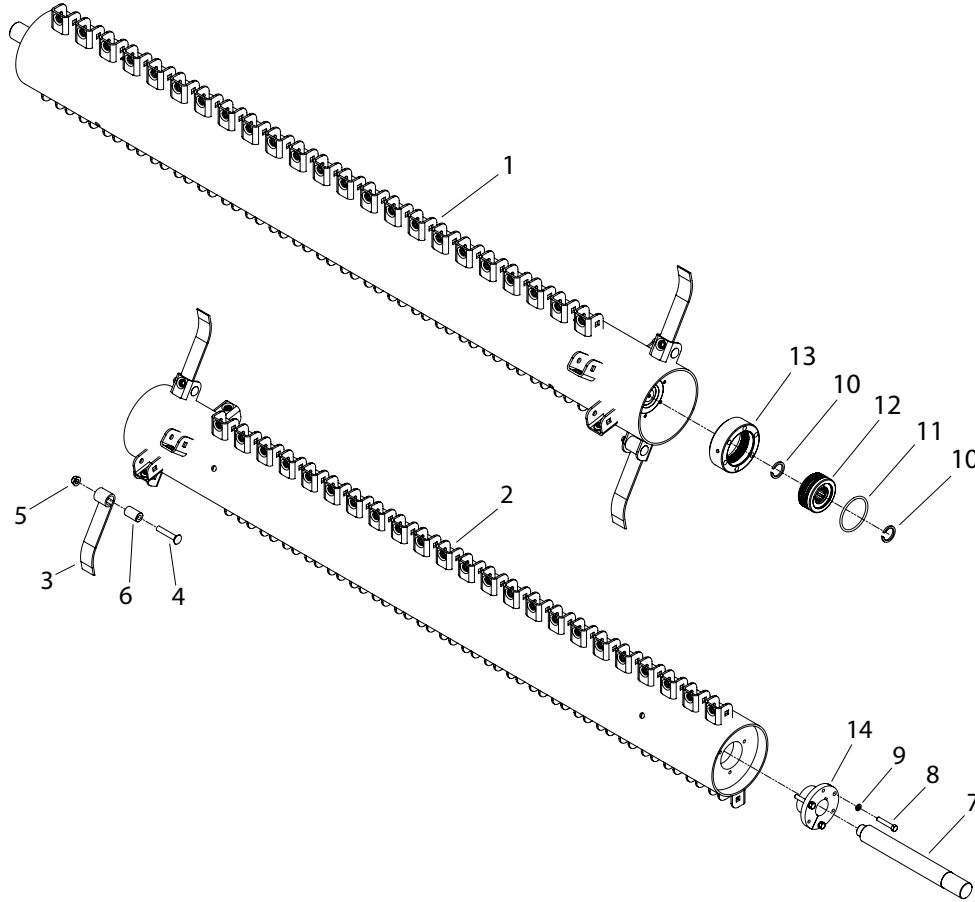

ITEM NO.	PART NUMBER	DESCRIPTION	QTY.
1	507-2-0299	FLAIL TUBE WELD - 13' - LH	1
	507-2-0221	FLAIL TUBE WELD - 15' - LH	
	507-2-0135	FLAIL TUBE WELD - 18' - LH	
	507-2-0075	FLAIL TUBE WELD - 20' - LH	
	507-2-0080	FLAIL TUBE WELD - 22' - LH	
2	507-2-0300	FLAIL TUBE WELD - 13' - RH	1
	507-2-0220	FLAIL TUBE WELD - 15' - RH	
	507-2-0134	FLAIL TUBE WELD - 18' - RH	
	507-2-0076	FLAIL TUBE WELD - 20' - RH	
	507-2-0079	FLAIL TUBE WELD - 22' - RH	
3	505-3-0005	CUP KNIFE - 11"	
4	900-01792	BOLT, CARRIAGE 5/8-11 X 3.50, GR5 ZP	
5	900-06145	NUT, WHIZ 5/8	
6	505-3-0405	BUSHING CUP KNIFE	
7	507-3-0240	STUB SHAFT - 2.25 DIA	1
8	900-02526	BOLT, HEX HEAD 1/2 NC X 2-3/4, GR5 ZP	3
9	900-11013	WASHER, LOCK 1/2	3
10	900-39030	RETAINING RING 600 SERIES	1
11	901-09126	O-RING, FLAIL COUPLER	2
12	500-3-0629	FLAIL COUPLER	1
13	500-3-0345	DRIVE SLEEVE, OUTER	1
14	903-08461	TYPE E HUB, 2-1/4 BORE	1

## AUGER DRIVE COMPONENTS

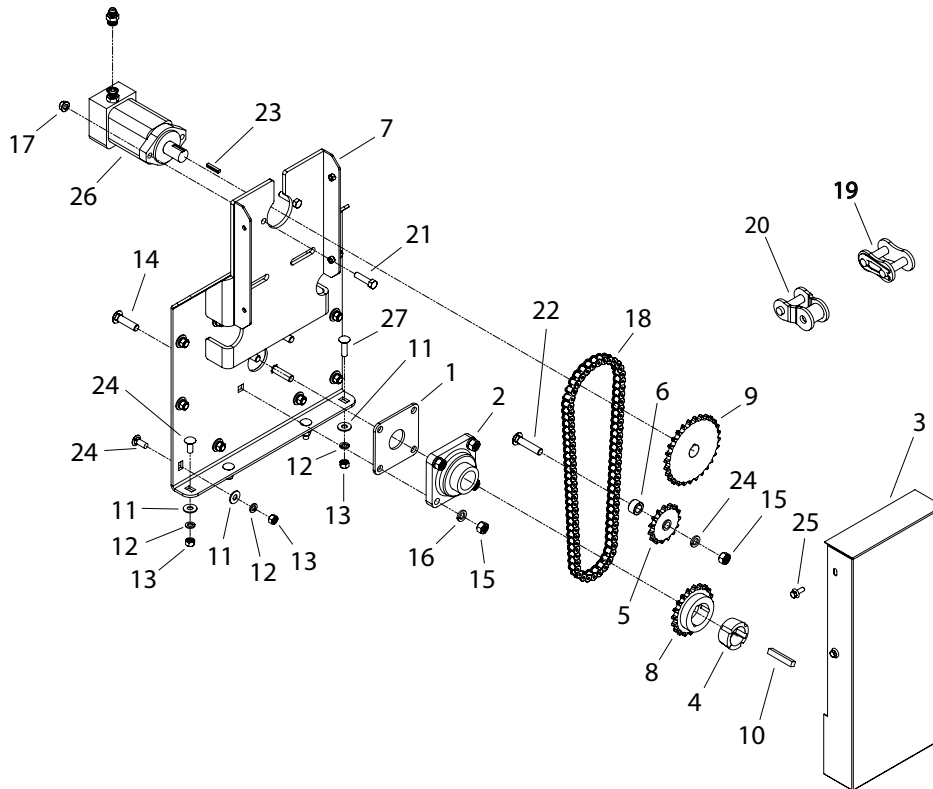

ITEM NO.	PART NUMBER	DESCRIPTION	QTY.
1	500-3-0990	PLASTIC SHIELD	1
2	901-01282	BEARING - NANFS 210-31 1.9375	1
3	507-3-0543	SHIELD - AUGER	1
4	903-08450	BUSHING TAPPER LOCK 2012 - 1.93 B	1
5	903-11066	IDLER SPROCKET - 60B15H .63 BORE	1
6	507-3-0595	STANDOFF - IDLER	1
7	507-2-0280	BEARING PLATE WELD - AUGER DRIVE	1
8	903-11062	SPROCKET - 60BTL20	1
9	903-11094	SPROCKET 60B28 1-1/4 B KEYED & SS	1
10	100-3-3331	KEY - 1/2 X 1/2 X 3	1
11	900-11035	WASHER, FLAT 1/2	14
12	900-11013	WASHER, LOCK 1/2	14
13	900-06009	NUT, HEX HEAD 1/2 NC	14
14	900-01788	BOLT, CARRIAGE 5/8 NC X 2-1/2, GR5 ZP	4
15	900-06013	NUT, HEX HEAD 5/8 NC	5
16	900-11015	WASHER, LOCK 5/8	5
17	900-06143	NUT, SPIRALOCK 1/2 NC	2
18	507-3-0594	ROLLER CHAIN - #60-1 X 70 LINKS + CONN & HALF LINK	1
19	903-03062	- RS-60 CONNECTING LINK	1
20	903-03089	- OFFSET LINK #60-1	1
21	900-01229	BOLT, HEX HEAD 1/2 NC X 2, GR5 ZP	2
22	900-01790	BOLT, CARRIAGE 5/8 NC X 3, GR5 ZP	1
23	100-3-3676	KEY - 1/4 X 5/16 STEP X 1-1/2 LONG	1
24	900-01750	BOLT, CARRIAGE BOLT 1/2 NC X 1-1/4, GR5 ZP	12
25	900-03438	BOLT, WHIZ 3/8 NC X 1	4
26	904-05223	HYD MOTOR, CHAR-LYNN #1041026	1
	904-05211	- SEAL KIT, CHAR-LYNN #61258	
27	900-01752	BOLT, CARRIAGE 1/2 NC X 1-3/4	2

### 3-POINT HITCH COMPONENTS

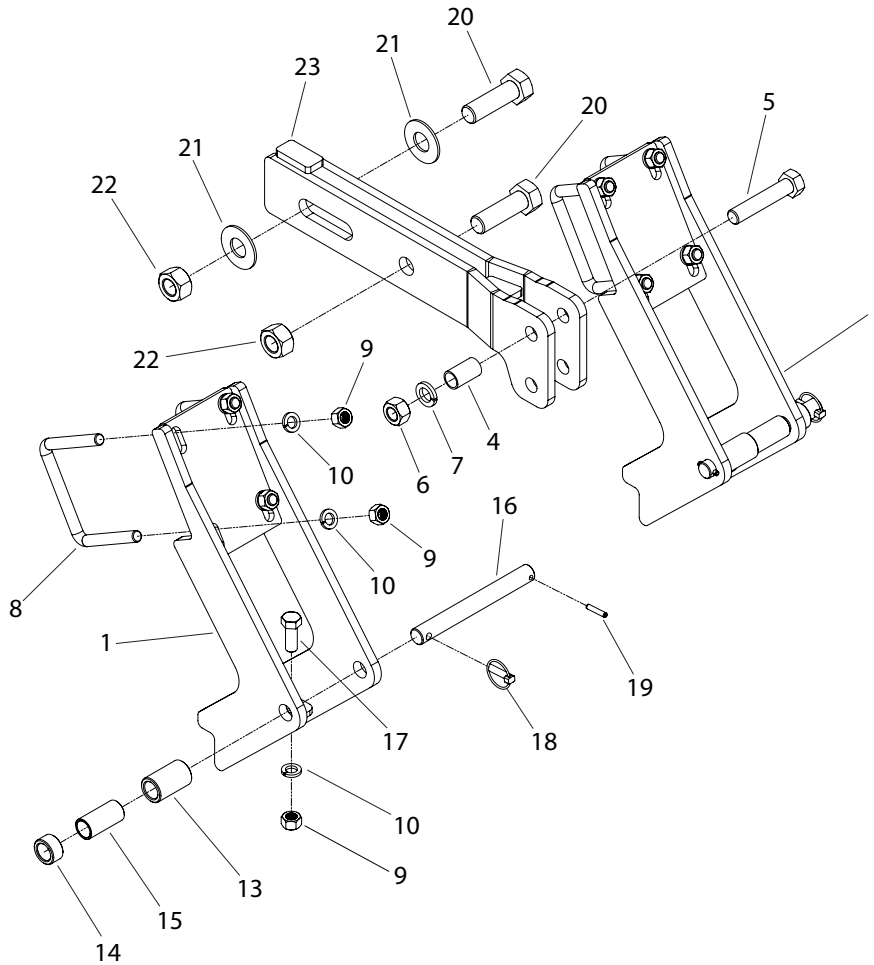

ITEM NO.	PART NUMBER	DESCRIPTION	QTY.
1	507-2-0192	LOWER 3-PT HITCH WELD	2
2	507-2-0303	UPPER MAST - TOP LINK	1
3	507-2-0020	UPPER MAST PLATE WELD	1
4	200-3-0151	MAST SPACER BUSHING	1
5	900-01531	BOLT, HEX HEAD 1 NC X 5, GR5 ZP	1
6	900-06019	NUT, HEX HEAD 1 NC	1
7	900-11021	WASHER, LOCK 1	1
8	200-3-0024	U-BOLT 3/4 X 6 X 5.5 X 1.5, GR5 ZP	4
9	900-06015	NUT, HEX HEAD 3/4 NC	12
10	900-11017	WASHER, LOCK 3/4	12
11	900-06518	NUT, TOP LOCK 1-1/4 NC	2
12	900-11042	WASHER, FLAT 1-1/4	2
13	200-3-0959	SPACER - LOWER 3 PT HITCH	2
14	200-3-0960	SPACER - LOWER 3 PT HITCH	2
15	200-3-0961	BUSHING - LOWER 3 PT	2
16	200-3-0962	PIN - LOWER 3PT	2
17	900-01403	BOLT, HEX HEAD 3/4 NC X 2, GR5 ZP	4
18	900-25012	KLICK PIN - 7/16 X 2	2
19	900-29204	PIN, SPRING, SLOTTED 5/16 X 1-5/8	2
20	900-01596	BOLT, HEX HEAD 1-1/4 NC X 4, GR5 ZP	2
	507-1-0002	CARTON - 3 PT HITCH	

## PULL TYPE HITCH COMPONENTS

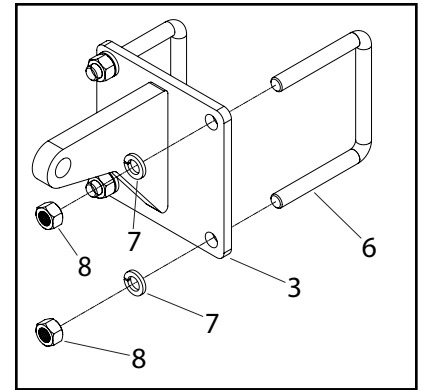
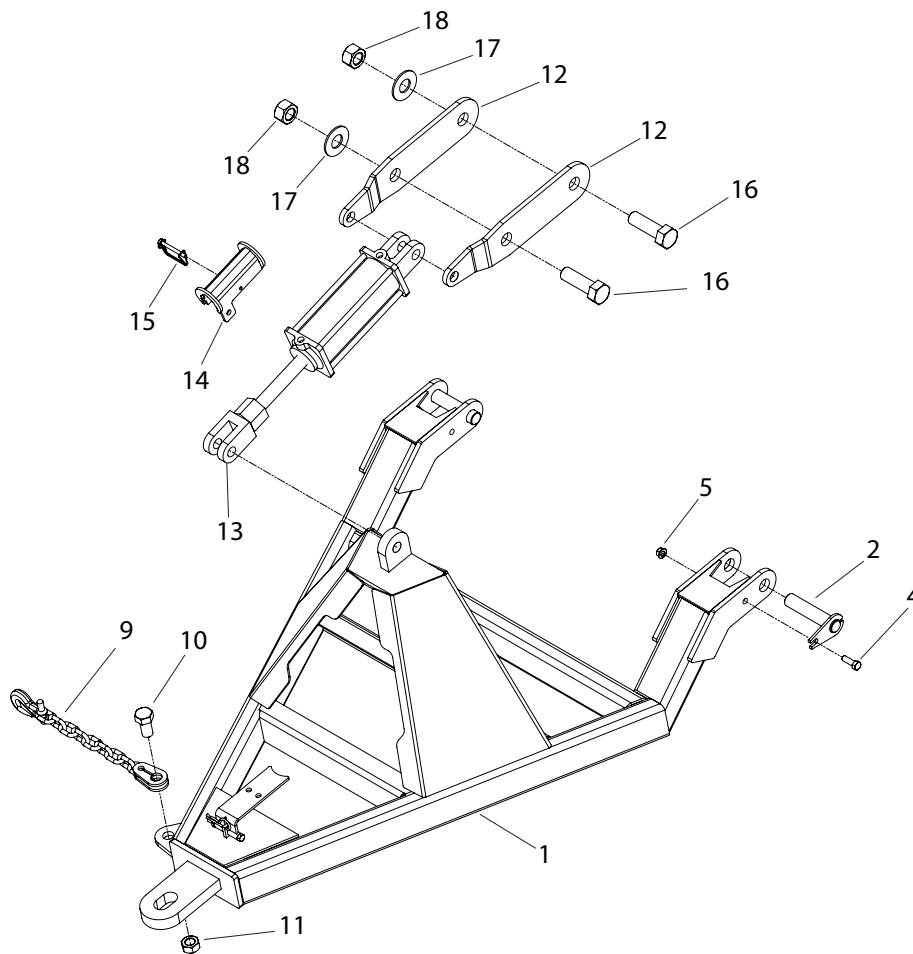

**2008 & OLDER MODELS**

ITEM NO.	PART NUMBER	DESCRIPTION	QTY.
1	507-2-0027	HITCH WELD - PULL TYPE	1
2	500-2-0684	1-1/4" PIN WELDMENT	2
3	507-2-0033	TOP EAR WELD	1
4	900-01225	BOLT, HEX HEAD 1/2 NC X 1-1/2, GR5 ZP	2
5	900-06143	NUT, SPIRALOCK 1/2 NC	2
6	200-3-0024	U-BOLT 3/4 X 6 X 5.5 X 1.5, GR ZP	2
7	900-11017	WASHER, LOCK 3/4	4
8	900-06015	NUT, HEX HEAD 3/4 NC	4
9	905-07123	TOW CHAIN SAFETY 21,000 LB	1
10	900-01511	BOLT, HEX HEAD 1 NC X 2, GR5 ZP	1
11	900-06514	NUT, TOP LOCK 1 NC	1
12	507-3-0580	CYL MOUNT PLATE - PULL TYPE	2
13	905-21400	CYLINDER, 3-1/2 X 8 W/ DEPTH STOP	1
14	700-2-0159	CYLINDER STOP	1
15	900-42055	LOCK PIN	1
16	900-01596	BOLT, HEX HEAD 1-1/4 X 4 NC, GR5 ZP	2
17	900-11042	WASHER, FLAT 1-1/4	2
18	900-06518	NUT, TOP LOCK 1-1/4 NC	2
	507-1-0003	CARTON - PULL TYPE HITCH	

# FRONT CASTER WHEEL COMPONENTS

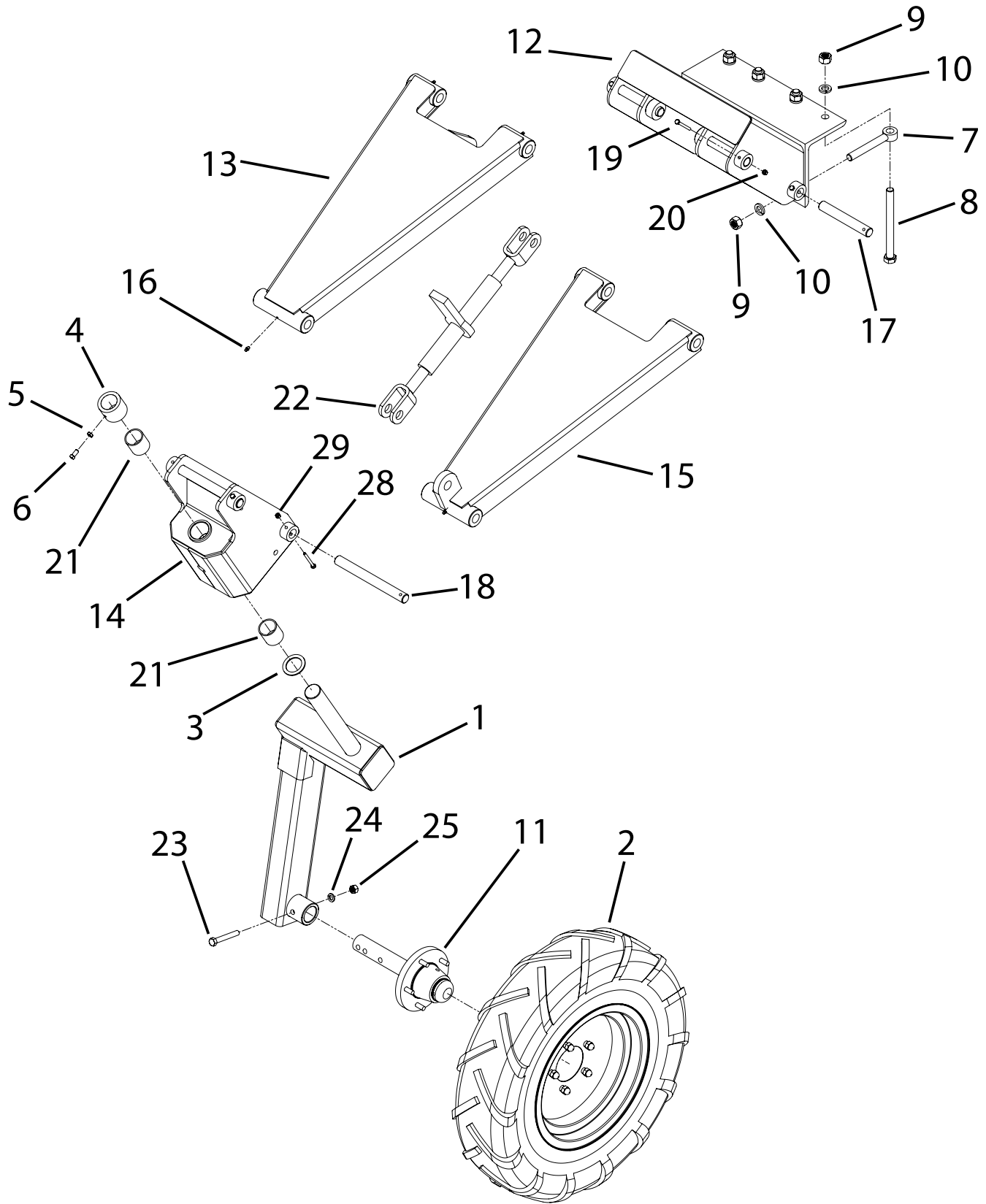

## FRONT CASTER WHEEL COMPONENTS

ITEM NO.	PART NUMBER	DESCRIPTION	QTY.
1	507-2-0103	LOWER CASTER WELDMENT	1
2	500-2-0157	TIRE & RIM ASSEMBLY RH	1
	500-2-0158	TIRE & RIM ASSEMBLY LH	
	905-09078	- RIM, 15" X 6" X 5 BOLT	
	905-09100	- TIRE, 7.6 X 15 TRCT 10 PLY	
3	901-01259	THRUST BEARING	1
4	500-3-0928	COLLAR	1
5	900-06270	NUT, JAM 3/8	1
6	900-16031	SCREW, SET, SQUARE HEAD 3/8-16 X 3/4	1
7	900-03463	BOLT, EYE 3/4, GR5 ZP	4
8	900-01437	BOLT, HEX HEAD 3/4 NC X 8-1/2, GR5 ZP	4
9	900-06015	NUT, HEX HEAD 3/4 NC	8
10	900-11017	WASHER, LOCK 3/4	8
11	500-2-0161	HUB & SPINDLE ASSEMBLY	1
12	507-2-0105	FRONT CASTER MOUNT WELD	1
13	507-2-0101	PARALLEL LINK ARM	1
14	507-2-0028	UPPER CASTER WELDMENT	1
15	507-2-0102	LOWER PARALLEL LINK ARM	1
16	905-15024	ZERK, STRAIGHT 1/4-28	7
17	507-3-0179	PIN - CASTER WHEEL LINKAGE	4
18	507-3-0180	LONG PIN - CASTER WHEEL LINKAGE	2
19	900-01021	BOLT, HEX HEAD 1/4 NC X 2 1/2, GR5 ZP	6
20	900-06496	NUT, TOP LOCK 1/4 NC	6
21	901-01261	OILITE BUSHING	2
22	905-23014	RATCHET JACK HEAVY DUTY	1
23	900-01241	BOLT, HEX HEAD 1/2 X 3-1/2 NC, GR ZP	1
24	900-11013	WASHER, LOCK 1/2	1
25	900-06009	NUT, HEX 1/2 NC	1
	507-2-0106	FRONT CASTER WHEEL ASSY - INCLUDES: #1 - #25	
	507-2-0104	CASTER WHEEL LINKAGE ASSEMBLY - FRONT - INCLUDES: #12 - #22	

# REAR CASTER WHEEL COMPONENTS

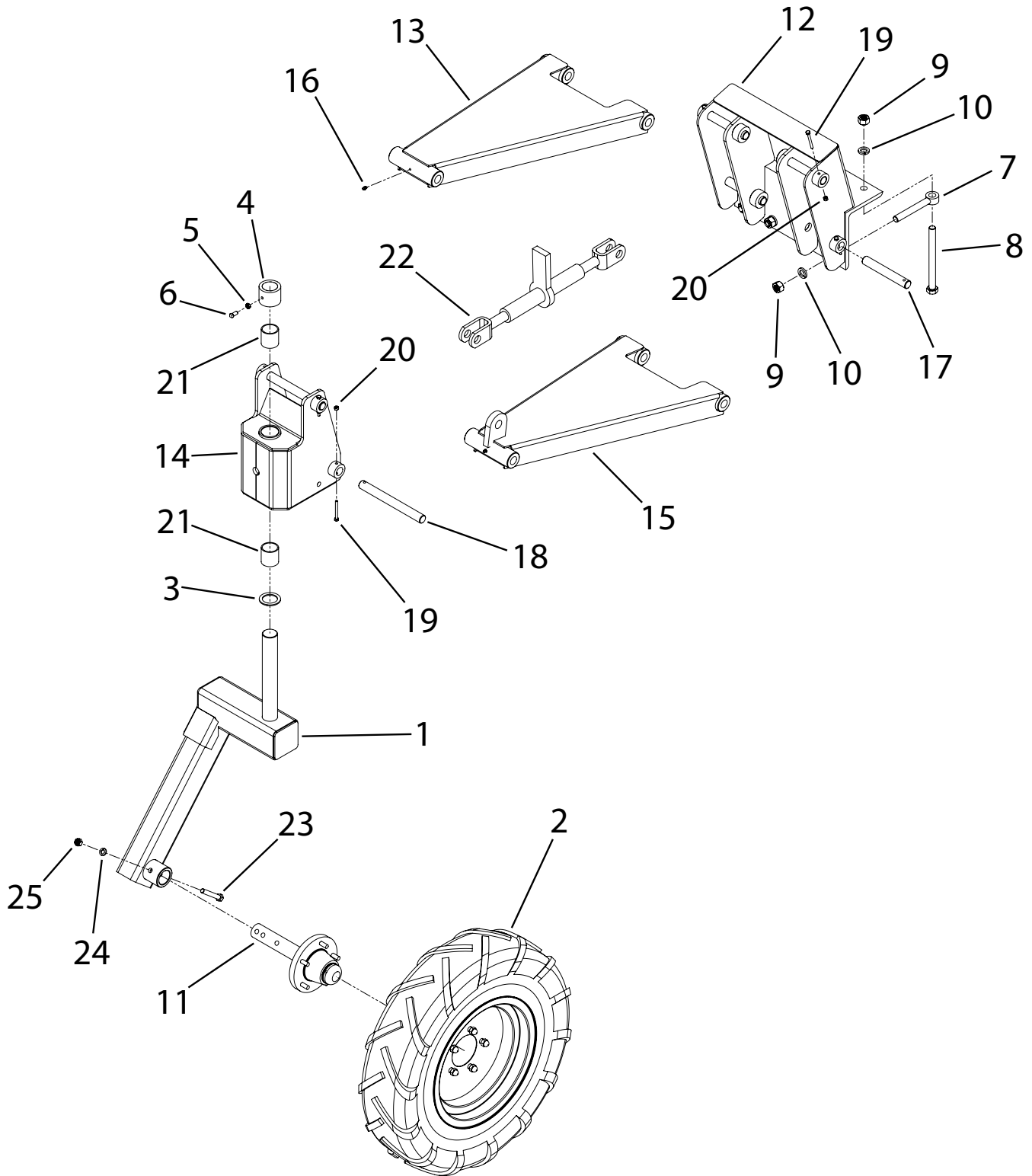



## REAR CASTER WHEEL COMPONENTS

ITEM NO.	PART NUMBER	DESCRIPTION	QTY.
1	507-2-0103	LOWER CASTER WELDMENT	1
2	500-2-0157	TIRE & RIM ASSEMBLY RH	1
	905-09078	- RIM, 15" X 6" X 5 BOLT	
	905-09100	- TIRE, 7.6 X 16 TRCT 10 PLY	
3	901-01259	THRUST BEARING	1
4	500-3-0928	COLLAR	1
5	900-06270	NUT, JAM 3/8	1
6	900-16031	SCREW, SET, SQUARE HEAD 3/8-16 X 3/4	1
7	900-03463	BOLT, EYE 3/4 NC, GR5 ZP	4
8	900-01437	BOLT, HEX HEAD 3/4 NC X 8-1/2, GR5 ZP	4
9	900-06015	NUT, HEX HEAD 3/4 NC	8
10	900-11017	WASHER, LOCK 3/4	8
11	500-2-0161	HUB & SPINDLE ASSEMBLY	1
12	507-2-0099	REAR CASTER MOUNT WELD	1
13	507-2-0101	PARALLEL LINK ARM	1
14	507-2-0028	UPPER CASTER WELDMENT	1
15	507-2-0102	LOWER PARALLEL LINK ARM	1
16	905-15024	ZERK, STRAIGHT 1/4-28	7
17	507-3-0179	PIN - CASTER WHEEL LINKAGE	4
18	507-3-0180	LONG PIN - CASTER WHEEL LINKAGE	2
19	900-01021	BOLT, HEX HEAD 1/4 NC X 2 1/2, GR5 ZP	6
20	900-06496	NUT, TOP LOCK 1/4 NC	6
21	901-01261	OILITE BUSHING	2
22	905-23014	RATCHET JACK HEAVY DUTY	1
23	900-01241	BOLT, HEX HEAD 1/2 NC X 3-1/2, GR5 ZP	1
24	900-11013	WASHER, LOCK 1/2	1
25	900-06009	NUT, HEX HEAD 1/2 NC	1
	507-2-0107	REAR CASTER WHEEL ASSY - INCLUDES: #1 - #34	
	507-2-0100	CASTER WHEEL LINKAGE ASSEMBLY - REAR - INCLUDES: #21 - #31	

# RIGID STRUT - DUAL (LARGE WHEELS)

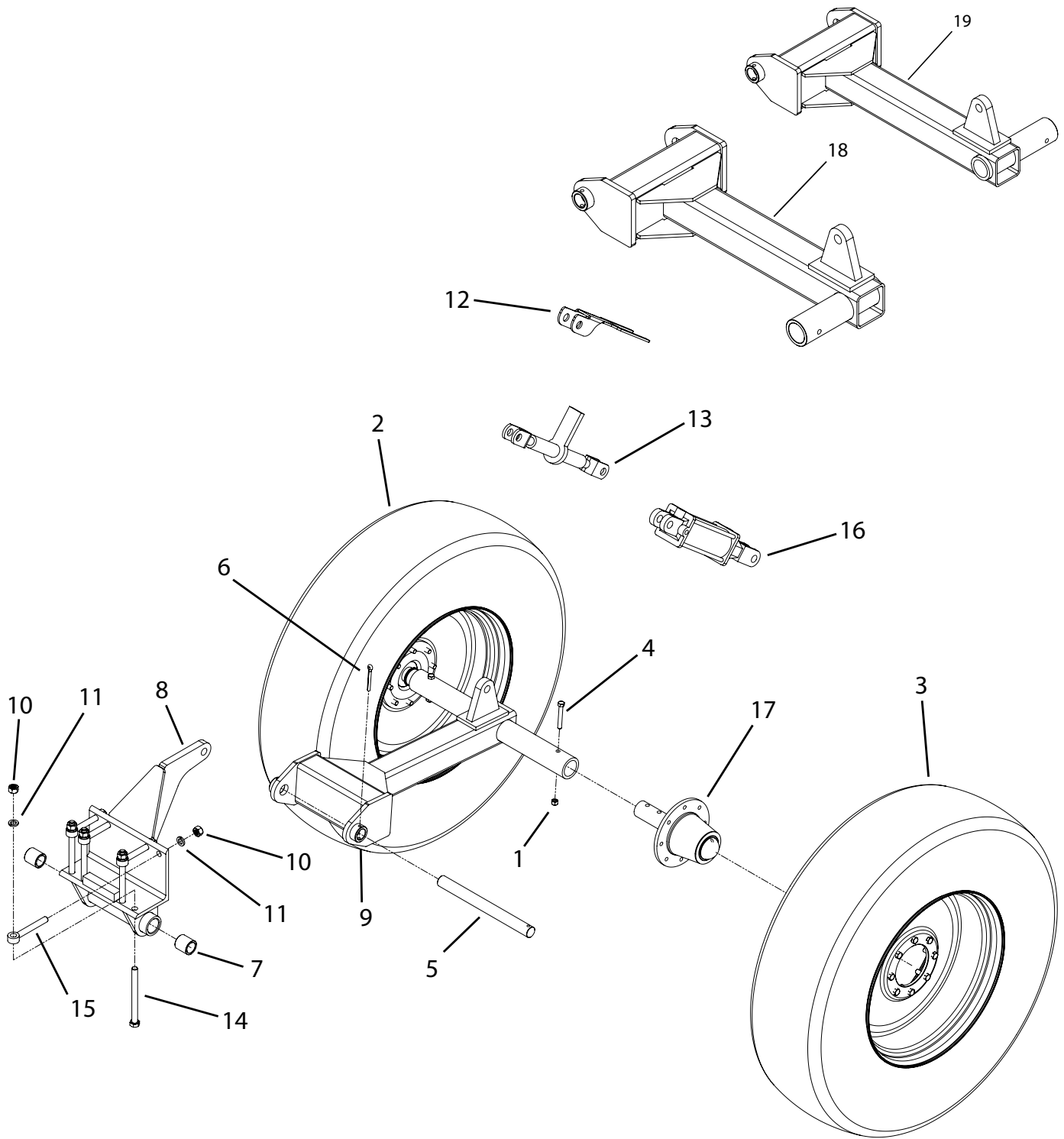

## RIGID STRUT - DUAL (LARGE WHEELS)

ITEM NO.	PART NUMBER	DESCRIPTION	QTY.
1	900-06504	NUT, TOP LOCK 1/2 NC	2
2	700-2-0168	TIRE & RIM ASSEMBLY RH	1
3	700-2-0167	TIRE & RIM ASSEMBLY LH	1
	905-09127	- RIM, 24" X 10" X 8 BOLT	
	905-09130	- TIRE, 12.4 X 24 8 PLY R1	
4	900-01241	BOLT, HEX HEAD 1/2 NC X 3.5, GR5 ZP	2
5	500-3-1328	PIN, PIVOT	1
6	900-23084	PIN, COTTER 3/8 X 3-1/2	1
7	500-3-1151	BUSHING	2
8	507-2-1046	MOUNTING ANGLE WELDMENT- REAR STRUT	1
9	507-2-0182	REAR STRUT WELDMENT - DUAL 30" - 36"	1
	507-2-0181	REAR STRUT WELDMENT - DUAL 22" - 26"	
10	900-06015	NUT, HEX HEAD 3/4 NC	8
11	900-11017	WASHER, LOCK 3/4	8
12	500-3-2202	RACHET JACK SUPPORT BRACKET	1
13	905-23014	RATCHET JACK HEAVY DUTY	1
14	900-01437	BOLT, HEX HEAD 3/4 NC X 8-1/2, GR5 ZP	4
15	900-03463	BOLT, EYE 3/4 NC, GR5 ZP	4
16	905-21398	CYLINDER, 3-3/4 X 8R BLACK	1
	905-21405	- SEAL KIT, 3-3/4	
	905-21290	CYLINDER, 3-1/2 X 8R BLACK	
	905-21371	- SEAL KIT, 3-1/2	
17	500-2-0165	HUB & SPINDLE ASSEMBLY	1
18	507-2-0187	REAR STRUT WELD - SINGLE RH	
19	507-2-0188	REAR STRUT WELD - SINGLE LH	

# RIGID STRUT - DUAL (MEDIUM WHEELS)

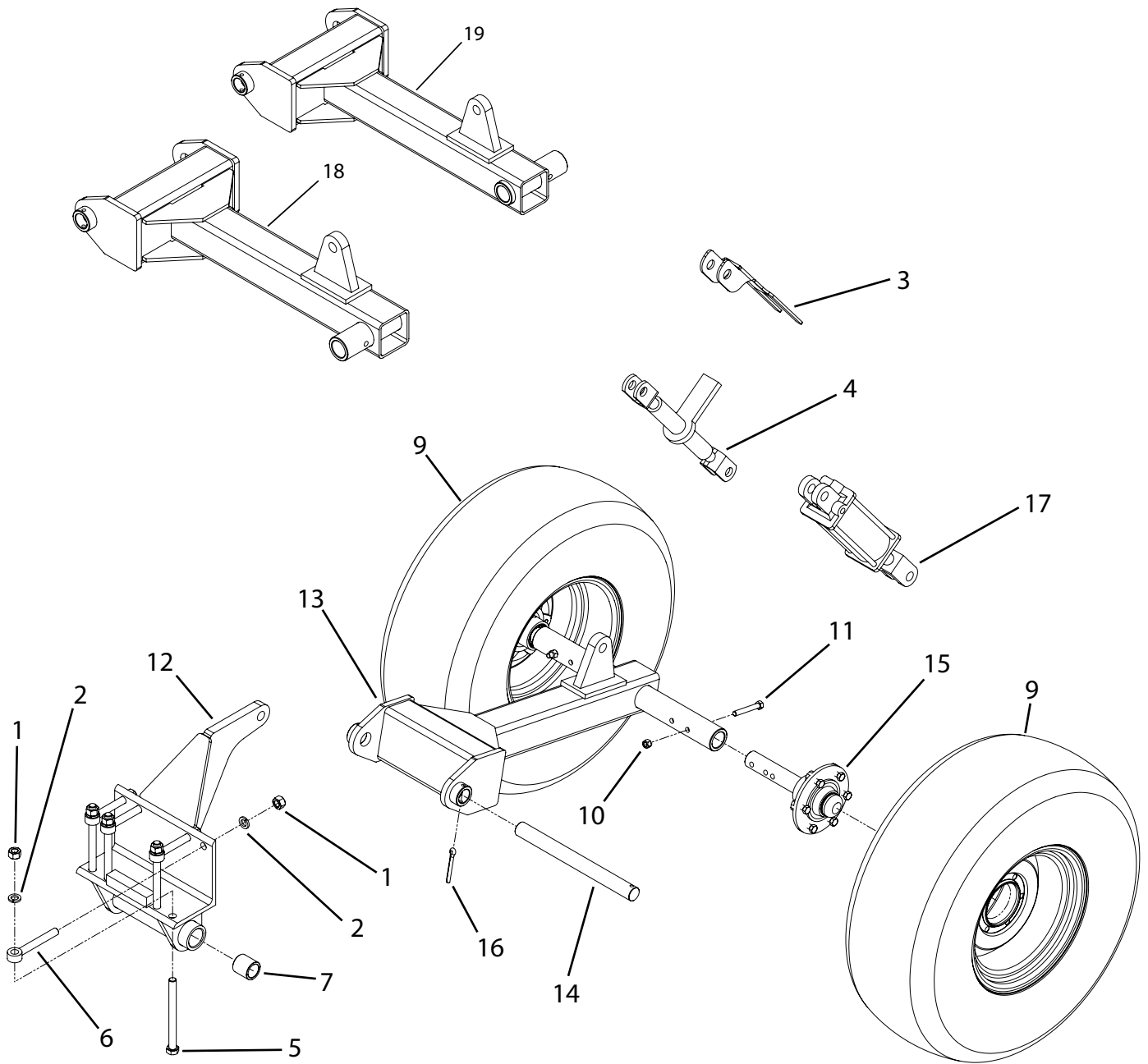

## RIGID STRUT - DUAL (MEDIUM WHEELS)

ITEM NO.	PART NUMBER	DESCRIPTION	QTY.
1	900-06015	NUT, HEX HEAD 3/4 NC	8
2	900-11017	WASHER, LOCK 3/4	8
3	500-3-2202	RACHET JACK SUPPORT BRACKET	1
4	905-23014	RATCHET JACK HEAVY DUTY	1
5	900-01437	BOLT, HEX HEAD 3/4 NC X 8-1/2, GR5 ZP	4
6	900-03463	BOLT, EYE 3/4 NC, GR5 ZP	4
7	500-3-1151	BUSHING	2
9	905-09181	TIRE & RIM ASSEMBLY	1
	905-09179	- RIM, 16" X 10" X 6 BOLT	
	905-19180	- TIRE, 12.5 X 16	
10	900-06504	NUT, TOP LOCK 1/2 NC	2
11	900-01241	BOLT, HEX HEAD 1/2 NC X 3-1/2, GR5 ZP	2
12	507-2-1046	MOUNTING ANGLE WELDMENT - REAR STRUT	1
13	507-2-0083	REAR STRUT WELD - DUAL 22" - 26"	1
	507-2-0093	REAR STRUT WELD - DUAL 30" - 36"	
14	500-3-1328	PIN, PIVOT	1
15	200-2-2344	HUB & SPINDLE ASSEMBLY	1
16	900-23084	PIN, COTTER 3/8 X 3-1/2	1
17	905-21398	CYLINDER, 3-3/4 X 8R BLACK	1
	905-21405	- SEAL KIT, 3-3/4	
	905-21290	CYLINDER, 3-1/2 X 8R BLACK	1
	905-21371	- SEAL KIT, 3-1/2	
18	507-2-0184	REAR STRUT WELD - SINGLE RH	
19	507-2-0186	REAR STRUT WELD - SINGLE LH	

## HYDRAULIC PLUMBING STRUT COMPONENTS

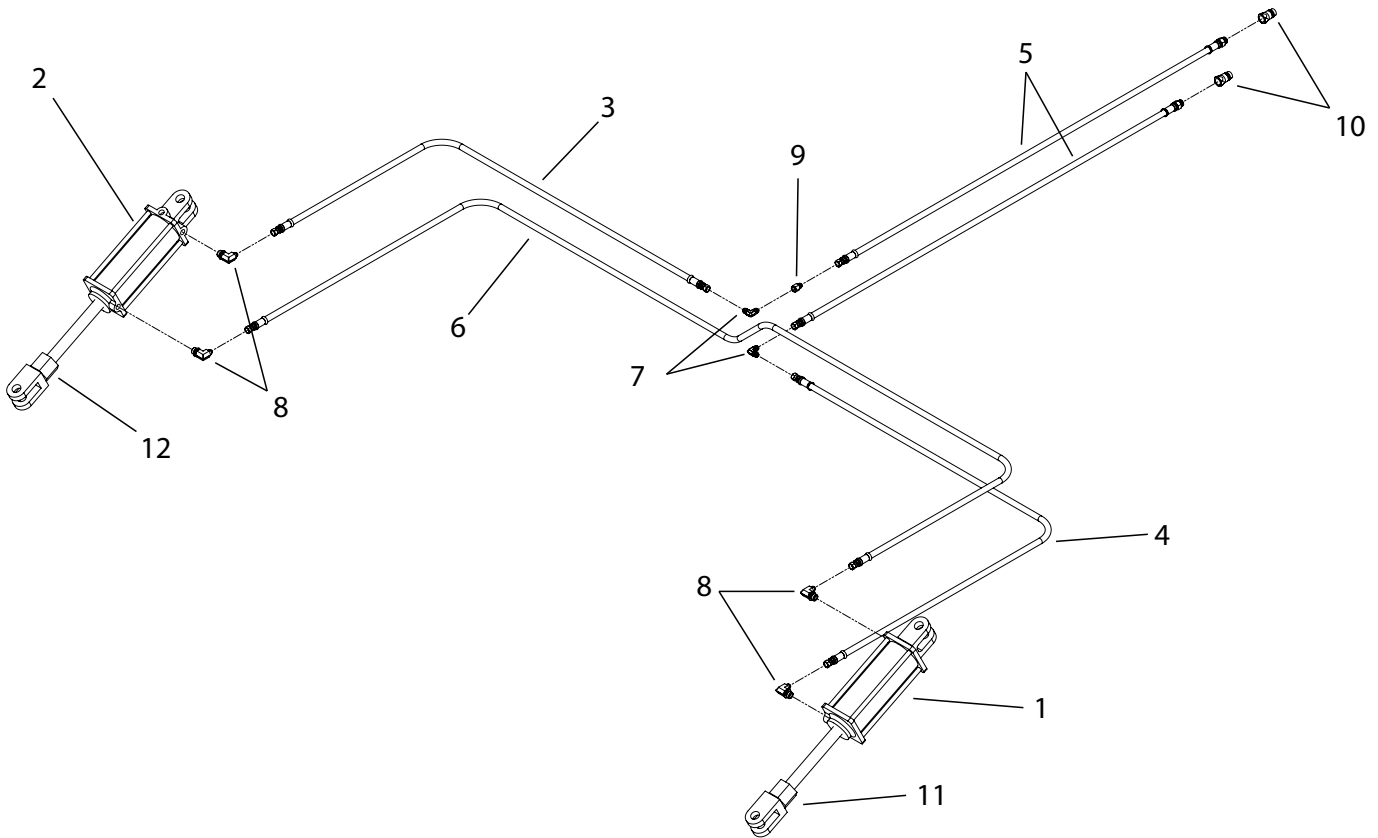

ITEM NO.	PART NUMBER	DESCRIPTION	QTY.
1	905-21290 905-21371	HYDRAULIC CYLINDER - 3.5 X 8R - SEAL KIT, 3-1/2	1
2	905-21398 905-21405	HYDRAULIC CYLINDER - 3.75 X 8R - SEAL KIT, 3-3/4	1
3	905-19194	HOSE, 3/8", 6FJIC X 6FJIC 90" LENGTH	1
4	905-19193	HOSE, 3/8", 6FJIC X 6FJIC 106" LENGTH	1
5	905-19210	HOSE, 3/8", 6FJIC X 8MORBSVL 120" LENGTH	2
6	905-19171	HOSE, 3/8", 6FJIC X 6FJIC 193" LENGTH	1
7	905-03113	ELBOW 90, 6MJIC X 6MJIC	2
8	905-03114	ELBOW 90, 6MJIC X 8MORB	4
9	905-03220	RESTICTOR 1/16" 6FJIC X 6MJIC	1
10	905-19126	QUICK COUPLER	2
11	905-21305	DEPTH STOP NUT, SMALL MECHANICAL	1
12	905-21407	DEPTH STOP NUT, LARGE MECHANICAL	1
	900-03463	BOLT, EYE 3/4 NC X 6	8
	900-01437	BOLT, HEX 3/4 NC X 8-1/2	8
	900-06015	NUT, HEX 3/4 NC	16
	900-11017	WASHER, LOCK 3/4	16
	507-1-0017	HYDRAULIC HOSE KIT	

## HYDRAULIC PLUMBING AUGER COMPONENTS

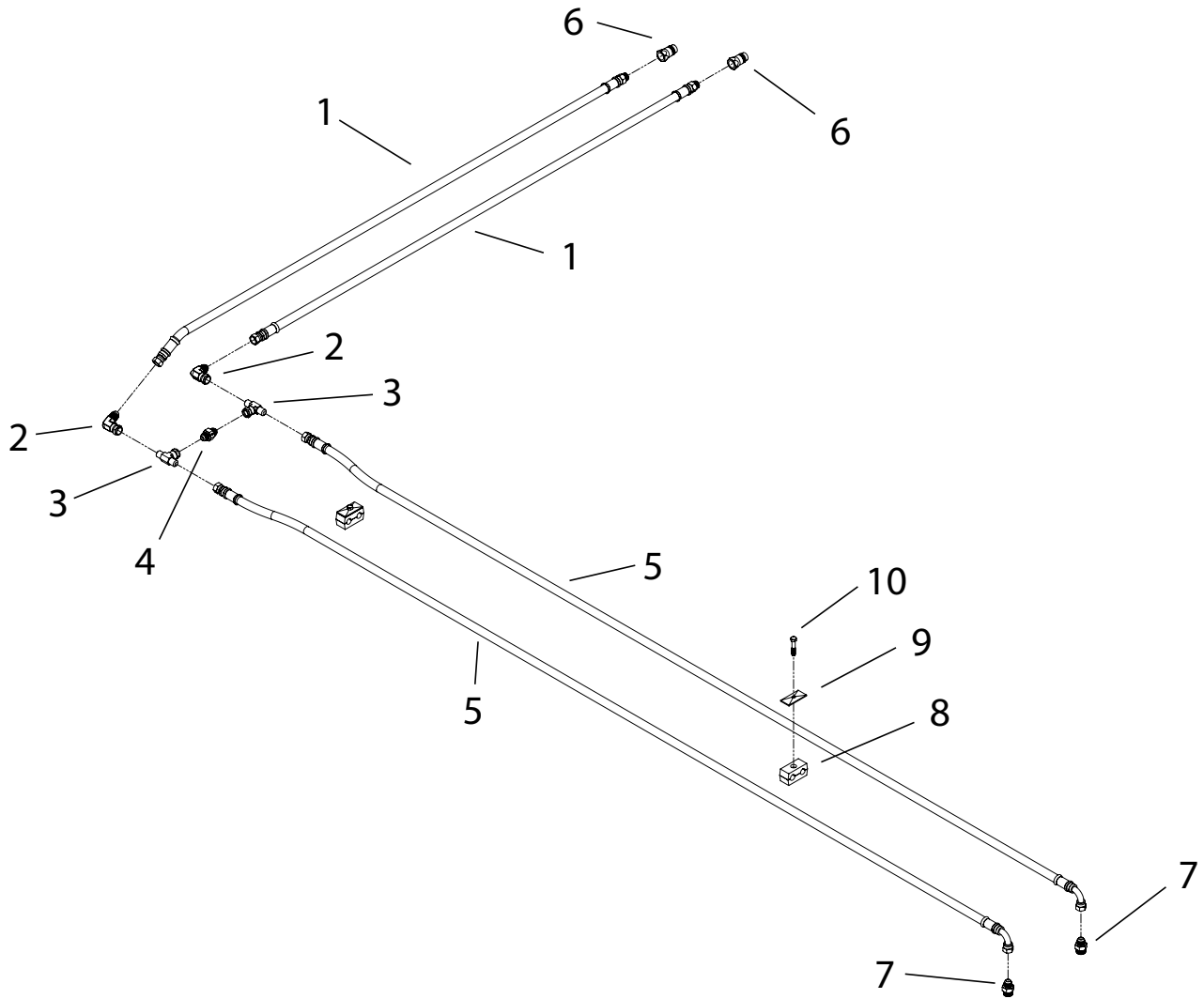

ITEM NO.	PART NUMBER	DESCRIPTION	QTY.	
1	905-19211	1/2 HOSE, 8MORB X 8FJIC x 120" (3 PT)	2	
	905-19233	1/2 HOSE, 8MORB X 8FJIC x 180" (Pull Type)	2	
2	905-03195	ELBOW 90, 8MJIC x 8FJIC	2	
3	905-03246	TEE, 8FJIC x 8MJIC x 8MJIC	2	
4	905-03247	CHECK VALVE, 8MJIC	1	
5	905-19250	(13') 1/2 HOSE, 8FJIC X 8FJIC(90°)	94" LENGTH	2
	905-19251	(15') 1/2 HOSE, 8FJIC X 8FJIC(90°)	112" LENGTH	
	905-19249	(18') 1/2 HOSE, 8FJIC X 8FJIC(90°)	124" LENGTH	
	905-19252	(20') 1/2 HOSE, 8FJIC X 8FJIC(90°)	144" LENGTH	
	905-19253	(22') 1/2 HOSE, 8FJIC X 8FJIC(90°)	160" LENGTH	
6	905-19126	QUICK COUPLER	2	
7	905-03121	ADAPTER, 10MORB X 8MJIC	2	
8	900-31069	CLAMP BODY	2	
9	900-31068	COVER PLATE, CLAMP BODY	2	
10	900-02356	BOLT, HEX HEAD 5/16 X 1-3/4, GR5 ZP	2	

## HYDRAULIC PLUMBING CASTER WHEELS 2 FRONT - 2 REAR

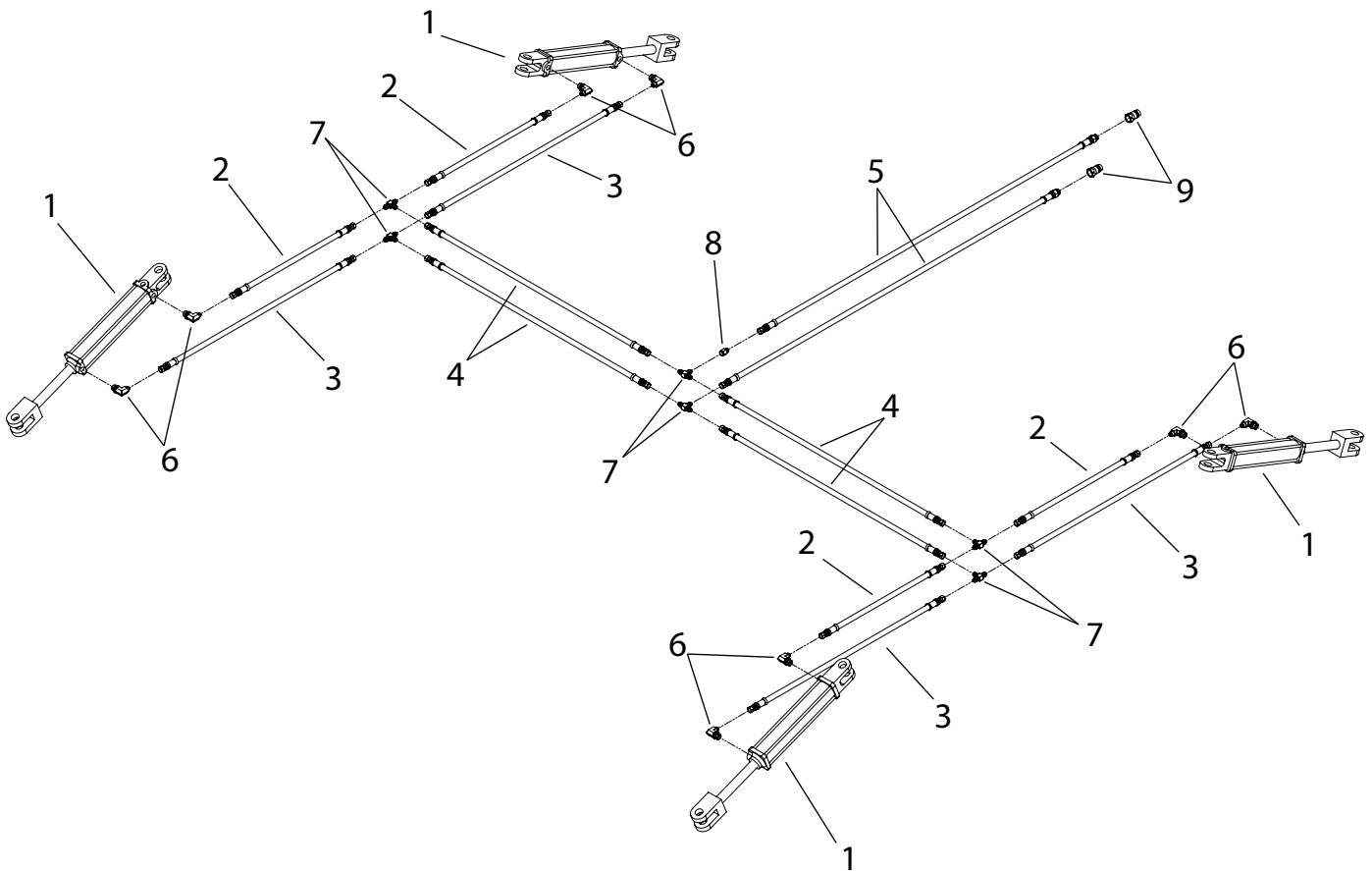

ITEM NO.	PART NUMBER	DESCRIPTION	QTY.
1	905-21390	HYDRAULIC CYLINDER, TIE ROD 2 X 10 - SEAL KIT, 2	4
2	905-19197	HOSE, 3/8", 6FJIC X 6FJIC	60" LENGTH 4
3	905-19142	HOSE, 3/8", 6FJIC X 6FJIC	70" LENGTH 4
4	905-19194	HOSE, 3/8", 6FJIC X 6FJIC	90" LENGTH 4
5	905-19210	HOSE, 3/8", 6FJIC X 8MORBSVL	120" LENGTH 2
6	905-03114	ELBOW, 90° 6MJIC X 8MORB	8
7	905-03112	TEE, 6MJIC X 6MJIC X 6MJIC	6
8	905-03220	RESTRICTOR, 6FJIC X 6MJIX, 1/16" HOLE	1
9	905-19126	QUICK COUPLER, FEMALE 8MORB	2



## HYDRAULIC PLUMBING CASTER WHEELS 2 REAR

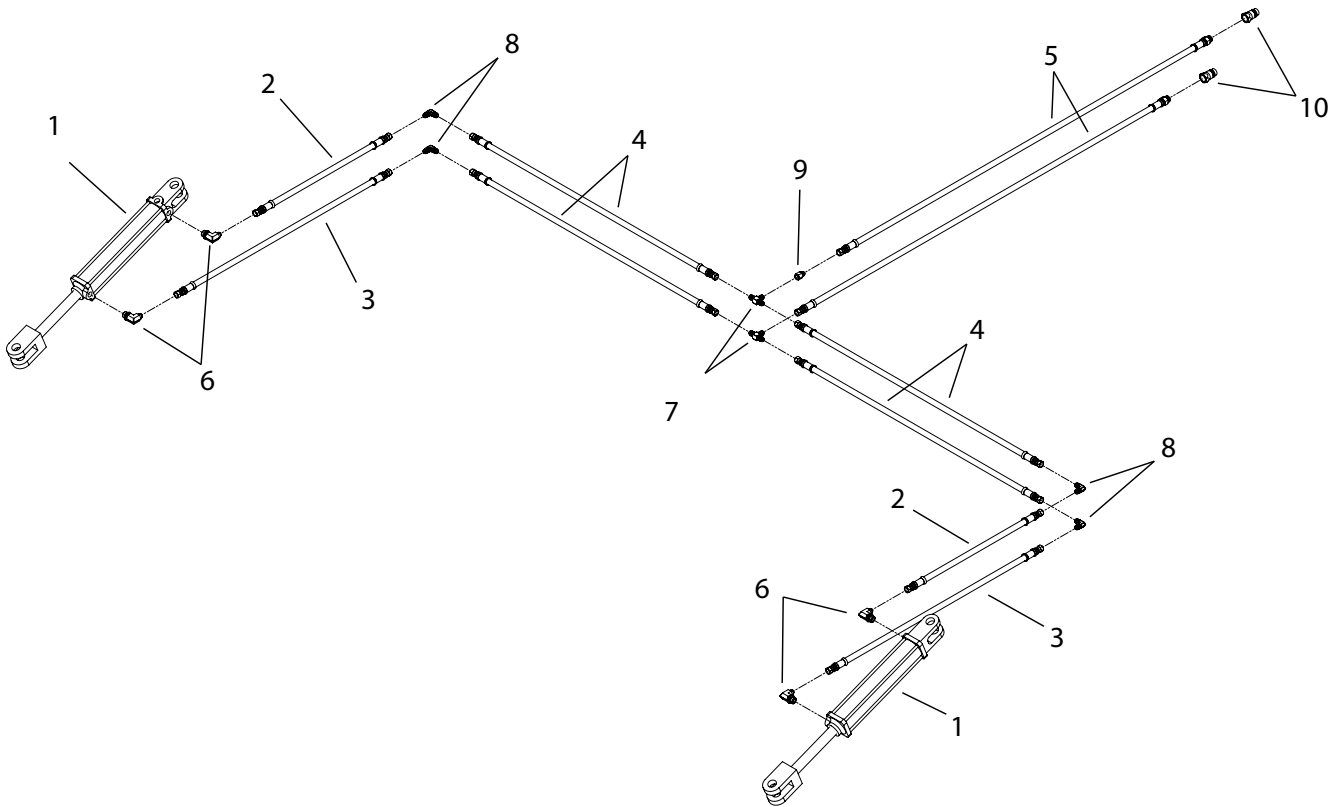

ITEM NO.	PART NUMBER	DESCRIPTION	QTY.
1	905-21390	HYDRAULIC CYLINDER, TIE ROD 2 X 10 - SEAL KIT, 2	4
2	905-19197	HOSE, 3/8", 6FJIC X 6FJIC	60" LENGTH 2
3	905-19142	HOSE, 3/8", 6FJIC X 6FJIC	70" LENGTH 2
4	905-19194	HOSE, 3/8", 6FJIC X 6FJIC	90" LENGTH 4
5	905-19210	HOSE, 3/8", 6FJIC X 8MORBSVL	120" LENGTH 2
6	905-03114	ELBOW, 90° 6MJIC X 8MORB	4
7	905-03112	TEE, 6MJIC X 6MJIC X 6MJIC	2
8	905-03113	ELBOW, 90° 6MJIC X 6MJIC	4
9	905-03220	RESTRICTOR, 6FJIC X 6MJIX, 1/16" HOLE	1
10	905-19126	QUICK COUPLER, FEMALE 8MORB	2

# END TRANSPORT STRUT COMPONENTS

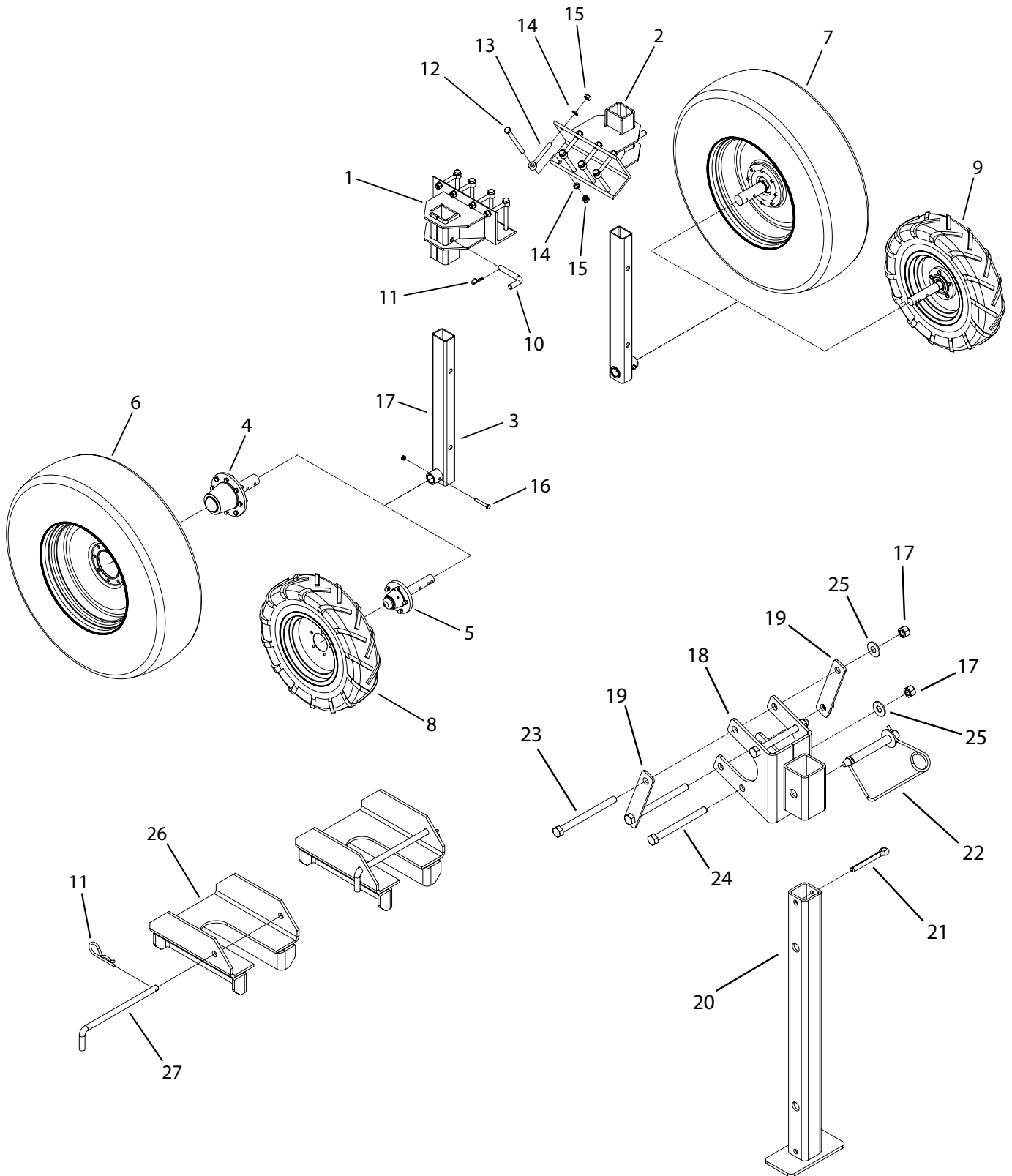

## END TRANSPORT STRUT COMPONENTS

ITEM NO.	PART NUMBER	DESCRIPTION	QTY.
1	507-2-0267	MOUNT WELD - REAR	1
2	507-2-0268	MOUNT WELD - FRONT	1
3	507-2-0269	LOWER STRUT WELDMENT	2
4	700-2-0165	HUB & SPINDLE ASSEMBLY (8-BOLT)	2
5	500-2-0161	HUB & SPINDLE ASSEMBLY (5-BOLT)	2
6	700-2-0168	TIRE & RIM ASSEMBLY RH - 12.4 X 24 (8-BOLT)	1
7	700-2-0167	TIRE & RIM ASSEMBLY LH - 12.4 X 24 (8-BOLT)	1
	905-09127	- RIM, 24" X 10" X 8 BOLT	
	905-09130	- TIRE, 12.4 X 24 8 PLY R1	
8	500-2-0157	TIRE & RIM ASSEMBLY RH - 7.6 X 15 (5-BOLT)	1
9	500-2-0158	TIRE & RIM ASSEMBLY LH - 7.6 X 15 (5-BOLT)	1
	905-09078	- RIM, 15" X 6" X 5 BOLT	
	905-09100	- TIRE, 7.6 X 15 TRCT 10 PLY (TITAN P/N: 4TG338)	
10	507-3-0496	PIN - END TRANSPORT HITCH	2
11	900-25007	PIN - HAIRCLIP 3/16, #6, ZP	4
12	900-01437	BOLT, HEX HEAD 3/4 X 8-1/2, GR5 ZP	8
13	900-03463	BOLT, EYE 3/4 X 6, GR5 ZP	8
14	900-11017	WASHER, LOCK 3/4	16
15	900-06015	NUT, HEX HEAD 3/4 NC	16
16	900-01241	BOLT, HEX HEAD 1/2 X 3-1/2, GR5 ZP	2
17	900-06504	NUT, TOP LOCK 1/2 NC	6
18	507-2-0271	STAND MOUNT	1
19	507-3-0502	STRAP - SUPPORT	2
20	507-2-0021	PARKING STAND WELD	1
21	900-23084	PIN, COTTER 3/8 X 3-1/2	1
22	900-42054	PIN, CLEVIS, SNAP LOCK 5/8 X 4	1
23	900-01253	BOLT, HEX HEAD 1/2 X 6, GR5 ZP	2
24	900-01251	BOLT, HEX HEAD 1/2 X 5-1/2, GR5 ZP	2
25	900-11035	WASHER, FLAT 1/2	4
26	507-2-0191	CASTER LOCK WELD	2
27	507-3-0358	PIN - CASTER LOCK	2

# END TRANSPORT FRAME COMPONENTS

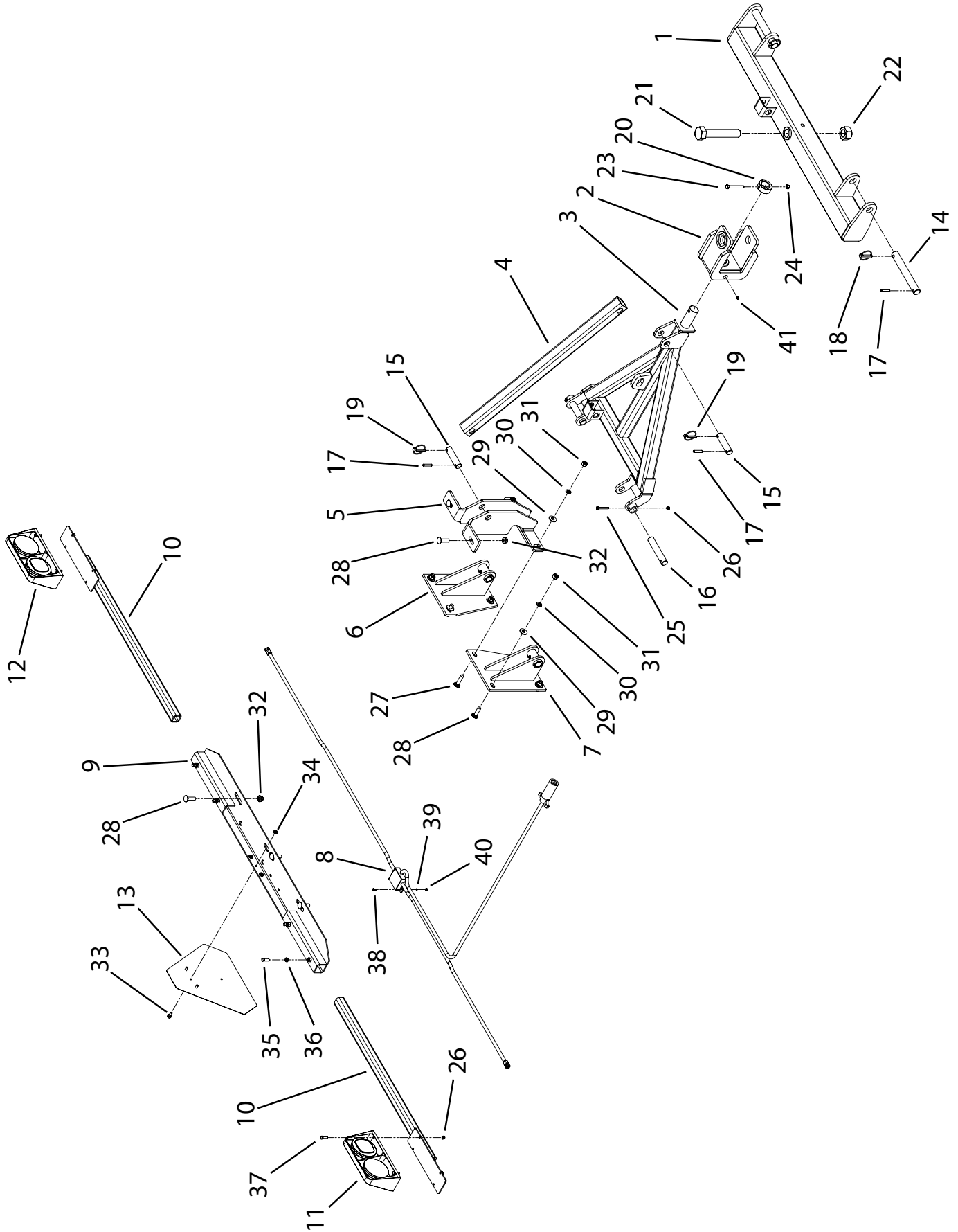

## END TRANSPORT FRAME COMPONENTS

ITEM NO.	PART NUMBER	DESCRIPTION	QTY.
1	507-2-0179	3PT BRACKET WELD	1
2	507-2-0177	PIVOT TUBE WELD	1
3	507-2-0174	HITCH WELD	1
4	507-3-0329	SUPPORT TUBE	1
5	507-2-0171	UPPER MOUNT WELD	1
6	507-2-0173	MOUNTING PLATE ASSY RH	1
7	507-2-0172	MOUNTING PLATE ASSY LH	1
8	904-01275	LIGHT WIRE HARNESS	1
9	507-2-0262	LIGHT MOUNT WELD	1
10	507-2-0263	SUPPOR TUBE - LIGHT KIT	2
11	904-01150	DUAL LAMP, RH	1
12	904-01149	DUAL LAMP, LH	1
13	500-3-1696	SMV SIGN	1
14	507-3-0338	PIN - 3PT	2
15	507-3-0337	PIN - SUPPORT TUBE	2
16	507-3-0335	PIN - HITCH	2
17	900-29204	PIN, ROLL 5/16 X 1-5/8	4
18	900-25012	PIN, KLIK 7/16 X 1-3/4	2
19	900-25010	PIN, KLIK 1/4 X 1-1/4	2
20	507-3-0334	COLLAR PIVOT TUBE	1
21	900-01607	BOLT, HEX HEAD 1-1/4 NC X 7, GR5 ZP	1
22	900-06518	NUT, TOP LOCK 1-1/4 NC	1
23	900-01125	BOLT, HEX HEAD 3/8 NC X 3, GR5 ZP	1
24	900-06500	NUT, TOP LOCK 3/8 NC	1
25	900-01017	BOLT, HEX HEAD 1/4 NC X 2, GR5 ZP	2
26	900-06496	NUT, TOP LOCK 1/4 NC	10
27	900-01753	BOLT, CARRIAGE 1/2 NC X 2, GR5 ZP	2
28	900-01752	BOLT, CARRIAGE 1/2 NC X 1-3/4, GR5 ZP	11
29	900-11035	WASHER, FLAT 1/2	8
30	900-11013	WASHER, LOCK 1/2	8
31	900-06009	NUT, HEX HEAD 1/2 NC	8
32	900-06143	NUT, SPIRALOCK 1/2 NC, GR8	5
33	900-03419	BOLT, SPIRALOCK 5/16 NC X 3/4, GR5 ZP	3
34	900-06137	NUT, SERRATED 5/16 NC	3
35	900-16033	SCREW, SET, SQUARE HEAD 3/8 NC X 1, CUP POINT	4
36	900-06270	NUT, JAM 3/8 NC	4
37	900-01009	BOLT, HEX HEAD 1/4 NC X 1, GR5 ZP	8
38	900-19060	SCREW, MACHING, PAN HEAD #8-32 X 1/2	2
39	900-11006	WASHER, LOCK #8	2
40	900-06192	NUT, LOCK #8-32	2
41	905-15024	ZERK, STRAIGHT 1/4-28	4

## LIGHT KIT COMPONENTS

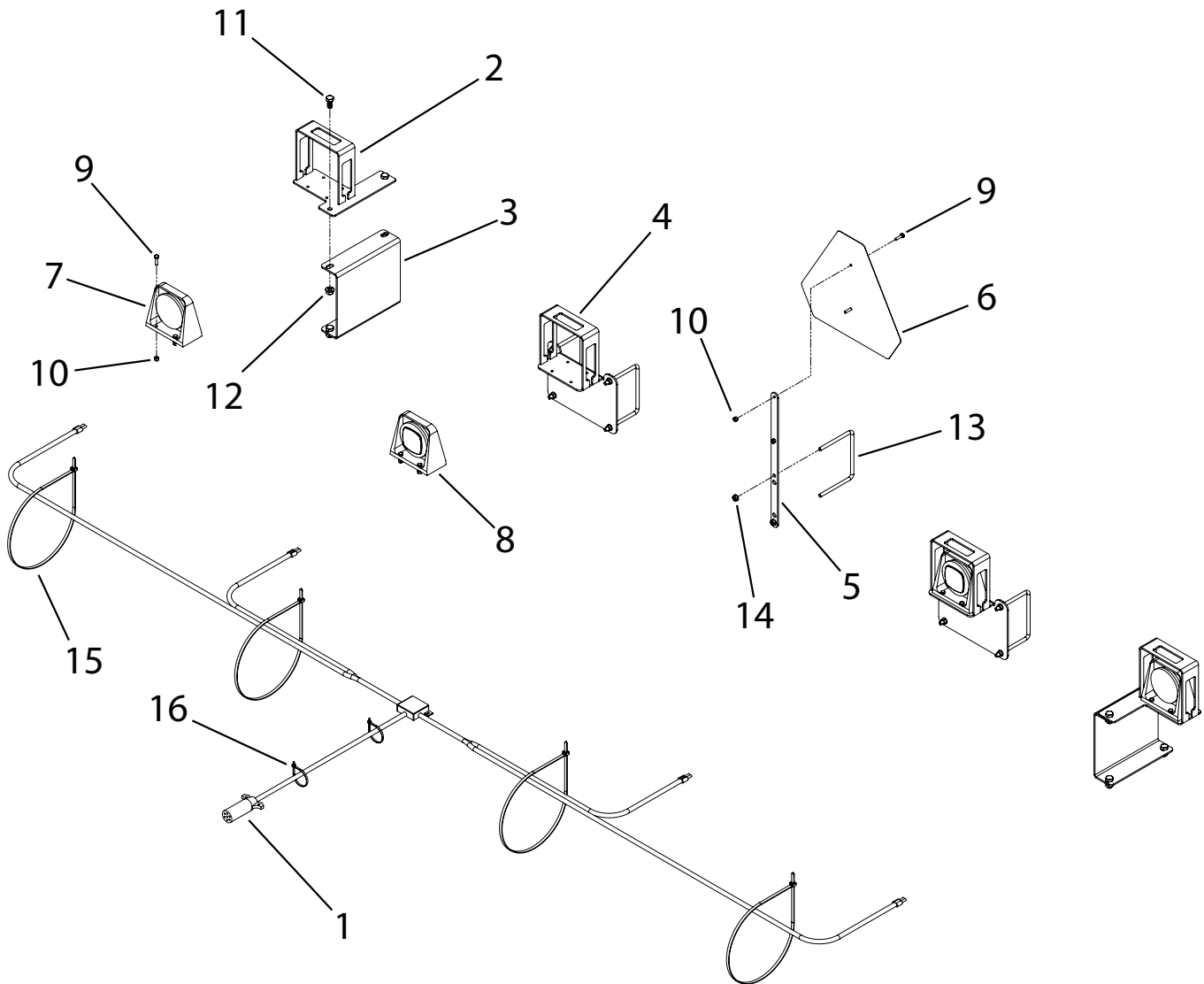

ITEM NO.	PART NUMBER	DESCRIPTION	QTY.
1	507-3-0218	WIRE HARNESS - (13' - 18')	1
	507-3-0237	WIRE HARNESS - (20')	
	507-3-0238	WIRE HARNESS - (22')	
2	507-2-0225	SIDE LIGHT BRACKET	2
3	507-3-0628	SPACER PLATE - SIDE LIGHT BRACKET	2
4	507-2-0108	LIGHT BRACKET	2
5	500-3-2091	SMV MOUNT	1
6	500-3-1696	SMV SIGN	1
7	904-01154	AMBER LAMP	2
8	904-01155	RED LAMP	2
9	900-01009	BOLT, HEX HEAD 1/4 NC X 1, GR5 ZP	16
10	900-06496	NUT, TOP LOCK 1/4 NC	16
11	900-01221	BOLT, HEX HEAD 1/2 NC X 1, GR5 ZP	8
12	900-06143	NUT, SPIRALOCK 1/2 NC	8
13	900-35000	U-BOLT, 3/8 NC X 6 X 5, GR5 ZP	5
14	900-06139	NUT, SERRATED 3/8 NC	2
15	905-07128	CABLE TIE, PLASTIC, 36" LONG	4
16	905-07127	CABLE TIE, PLASTIC, 7.5" LONG	2

## HUB & SPINDLE ASSEMBLY COMPONENTS

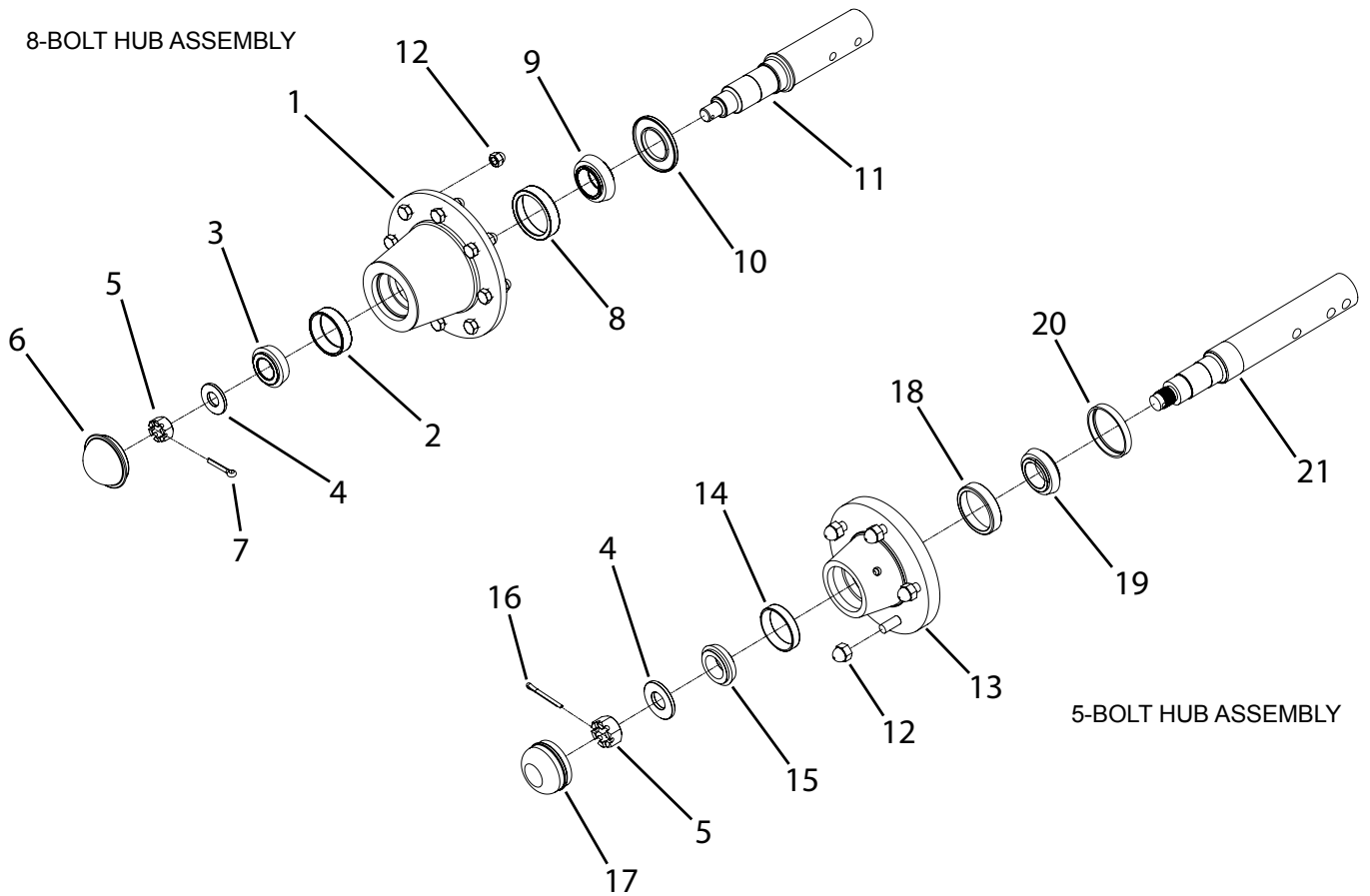

ITEM NO.	PART NUMBER	DESCRIPTION	QTY.
1	905-09136	HUB W/ CUPS (8-BOLT)	1
2	901-01324	BEARING CUP	1
3	901-01326	BEARING CONE	1
4	905-09067	WASHER, 7/8 SAE	1
5	900-06060	NUT, HEX HEAD, SLOTTED 7/8 NF	1
6	905-09135	HUB CAP	1
7	900-23064	PIN, COTTER 1/2 X 2	1
8	901-01152	BEARING CUP	1
9	901-01325	BEARING CONE	1
10	901-09215	SEAL	1
11	700-3-0143	SPINDLE	1
12	905-09011	NUT, HEX HEAD, WHEEL 1/2 NF	8
13	905-09003	HUB W/ CUPTS (5-BOLT)	1
14	901-01016	BEARING CUP	1
15	901-01015	BEARING CONE	1
16	900-23043	PIN, COTTER 3/16 X 1-1/2	1
17	905-09009	CAP, DUST	1
18	901-01022	BEARING CUP	1
19	901-01023	BEARING CONE	1
20	901-09002	SEAL, OIL TRANSCOM	1
21	500-3-0136	SPINDLE	1

## WEASLER PULL-TYPE PTO SHAFT WITH TORQ MASTER CLUTCH

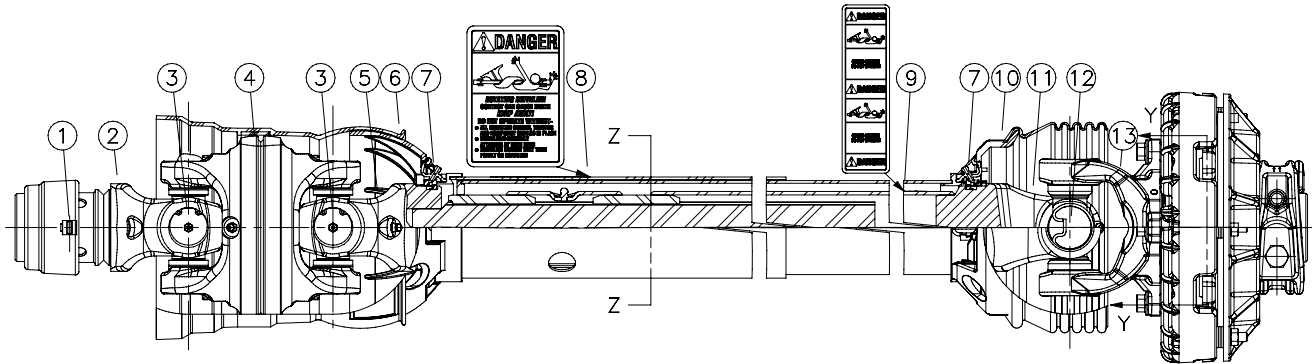

ITEM NO.	PART NUMBER	DESCRIPTION	QTY.
1	903-18106	SSL / AUTO-LOK REPAIR KIT 1-3/8"	1
	903-18326	SSL / AUTO-LOK REPAIR KIT 1-3/4"	1
2	903-18327	WWCV AUTO-LOK YOKE ASSEMBLY 1-3/8"	1
	903-18121	WWCV AUTO-LOK YOKE ASSEMBLY 1-3/4"	1
3	903-18328	AB8/AW24EBL CROSS & BEARING KIT	2
4	903-18329	WWCV CENTER HOUSING	1
5	903-18330	WWCV YOKE & SHAFT (1.69-20 SPLINE)	1
6	903-18057	OUTER GUARD	1
7	903-17774	GUARD REPAIR KIT	2
8	903-17455	SAFETY SIGN	1
9	903-17456	SAFETY SIGN	1
10	903-17910	INNER GUARD	1
11	903-17909	YOKE, TUBE, & SLIP SLEEVE	1
12	903-17239	55E CROSS & BEARING KIT	1
13	903-18145	OVER RUNNING FRICTION CLUTCH ASSEMBLY - 18303	1
	903-18283	GUARD SET	1
	903-18315	CV SLIP CLUTCH PTO, 1-3/8", COMPLETE	
	903-18314	CV SLIP CLUTCH PTO, 1-3/4", COMPLETE	



## WEASLER 2-POINT & 3-POINT PTO SHAFT WITH TORQ MASTER CLUTCH

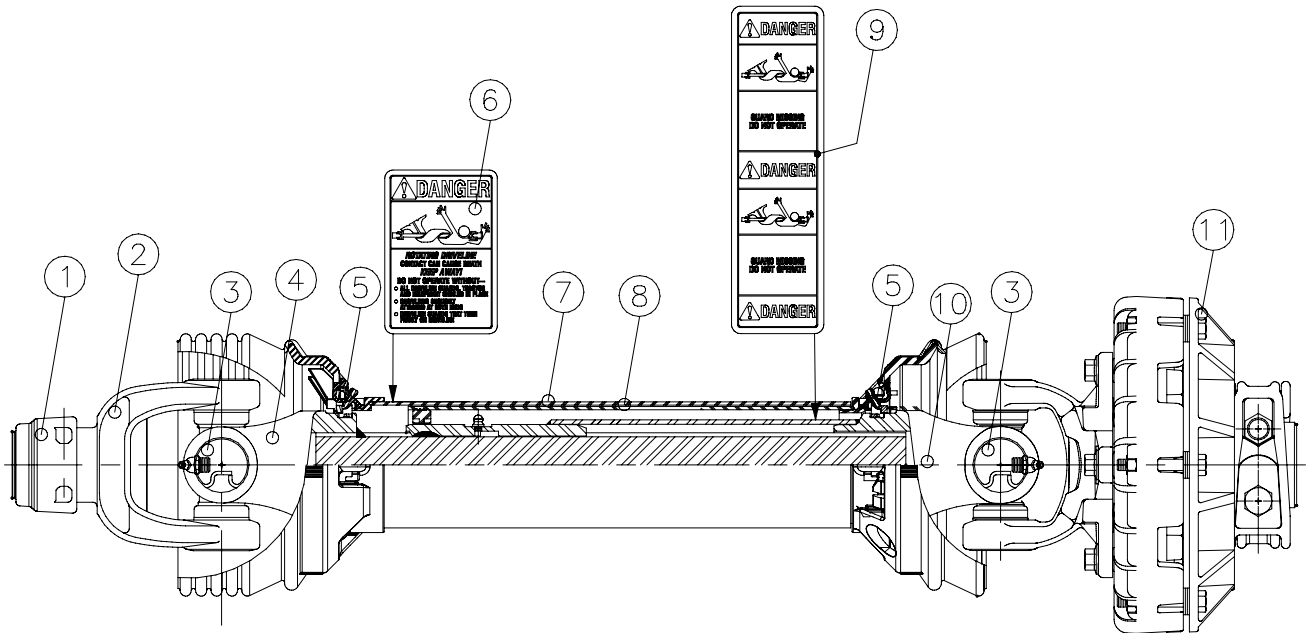

ITEM NO.	PART NUMBER	DESCRIPTION	QTY.
1	903-18323	SSL / AUTO-LOK REPAIR KIT, 1-3/8"	1
	903-17772	SSL / AUTO-LOK REPAIR KIT, 1-3/4"	1
2	903-17418	SAFETY SLIDE LOCK YOKE ASSEMBLY	1
3	903-17239	55E CROSS & BEARING KIT	2
4	903-17613	YOKE & SHAFT (1.69-20 SPLINE)	
5	903-17774	GUARD REPAIR KIT (NOT SHOWN)	2
6	903-17455	SAFETY SIGN	1
7	903-18319	OUTER GUARD	1
8	903-18320	INNER GUARD	1
9	903-17456	SAFETY SIGN	1
10	903-18321	YOKE, TUBE, & SLIP SLEEVE	1
11	903-18145	OVER RUNNING FRICTION CLUTCH ASSEMBLY - 18303	1
	903-18313	SLIP CLUTCH PTO, 1-3/8", COMPLETE	
	903-18335	SLIP CLUTCH PTO, 1-3/4", COMPLETE	

# WEASLER TORQMASTER CLUTCH COMPONENTS

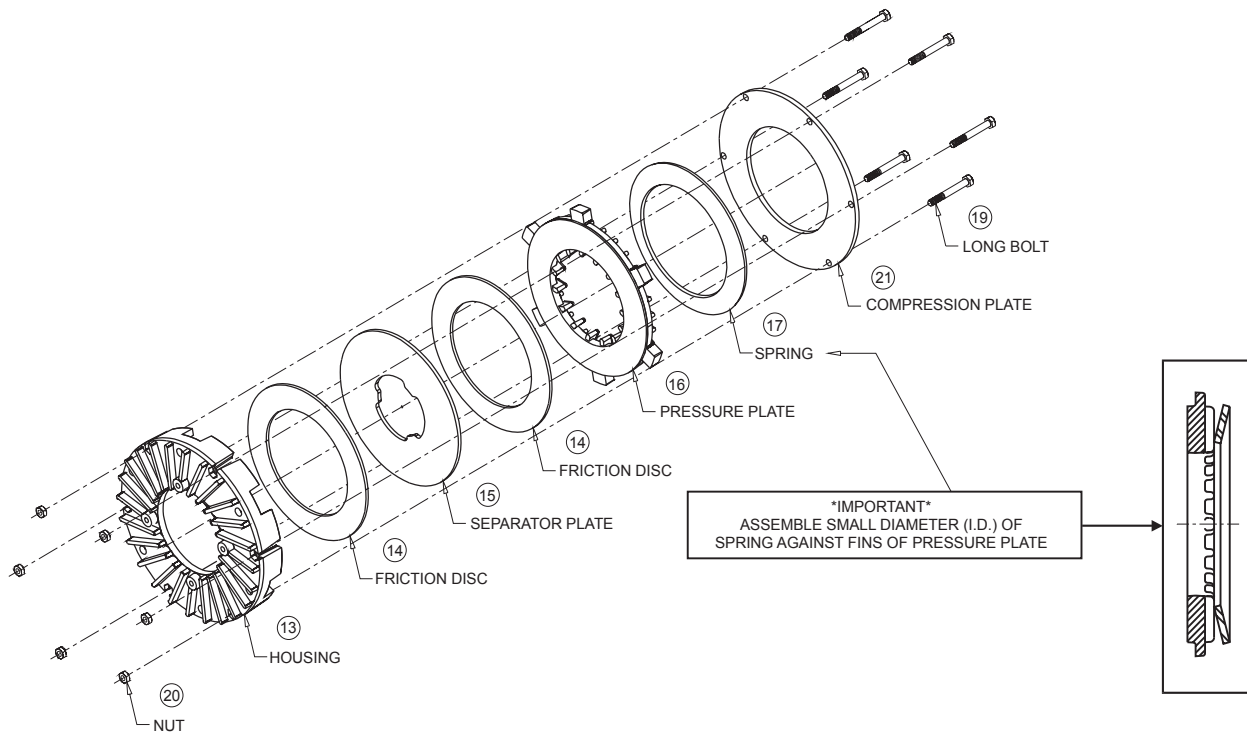
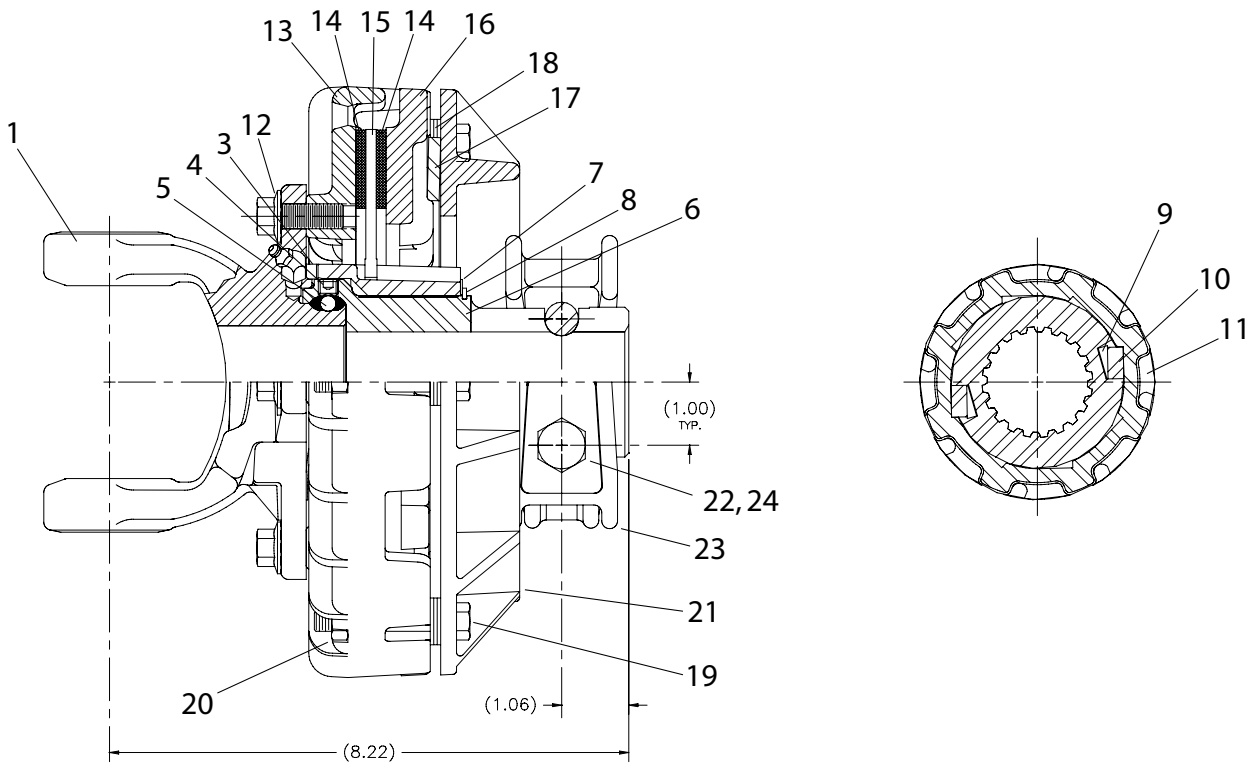

## WEASLER TORQMASTER CLUTCH COMPONENTS

ITEM NO.	PART NUMBER	DESCRIPTION	QTY.
1	903-18345	YOKE	1
2	903-18346	OVERRUNNING REPAIR KIT, (2, 6, 7, 8, 9) {Not Shown}	
3	903-18347	WAVE SPRING	1
4	903-18154	SET SCREW, .315-18 X .25 LG	1
5	903-18348	BALL, Ø.250, GRADE 5	31
6	903-18349	OVERRUNNING INNER HUB	1
7	903-18167	WASHER	1
8	903-18168	RETAINING RING	1
9	903-18352	LEAF SPRING	2
10	903-18350	OVERRUNNING KEY	2
11	903-18351	OVERRUNNING HUB	1
12	900-03055	BOLT, M10 X 1.50 X 25mm LG, CLASS 10.9	4
13	903-18341	HOUSING	1
14	903-18281	FRICTION DISC	2
15	903-18174	SEPARATOR PLATE	1
16	903-18342	PRESSURE PLATE	1
17	903-18343	SPRING	1
18	900-11236	WASHER, M8 NARROW	24
19	900-03053	BOLT, M8 X 1.25 X .60 LG, CLASS 10.9	6
20	900-06548	NUT, M8 X 1.25	6
21	903-18344	COMPRESSION PLATE	1
22	903-03098	BOLT, .500-13 X 3.50 LG., GRADE 8	2
23	903-18340	HUB CLAMP	2
24	900-06549	NUT, LOCK .500-13, GRADE G	2
	903-18336	CLAMP - INCLUDES: #22 - #24	
	903-18337	YOKE & HUB ASM. - INCLUDES: #1 - #11	
	903-18338	FRICTION PACK - INCLUDES: #12 - #21	
	903-18303	FRICTION OVERRUNNING CLUTCH ASSEMBLY - INCLUDES: 903-18336, 903-18337, 903-18338	

# CENTER DRIVE GEARBOX - 1:1 RATIO

**NOTES:**

A. GEAR RATIO IS 1:1 (INPUT CCW ON STUB SHAFT)

B) TORQUE 3/8-16 CAPSCREWS (ITEM 10) TO 35-40 FT LBS

C) STAMP PART NO. AND LOT NO. IN AREA SHOWN

D) FOUR EXTERNAL RETAINING RINGS (ITEM 13) ARE SHIPPED UNINSTALLED

E) INSTALL SOLID PLUG (ITEM 9) AND SHIP DIPSTICK IN SEPARATE BAG OR BOX

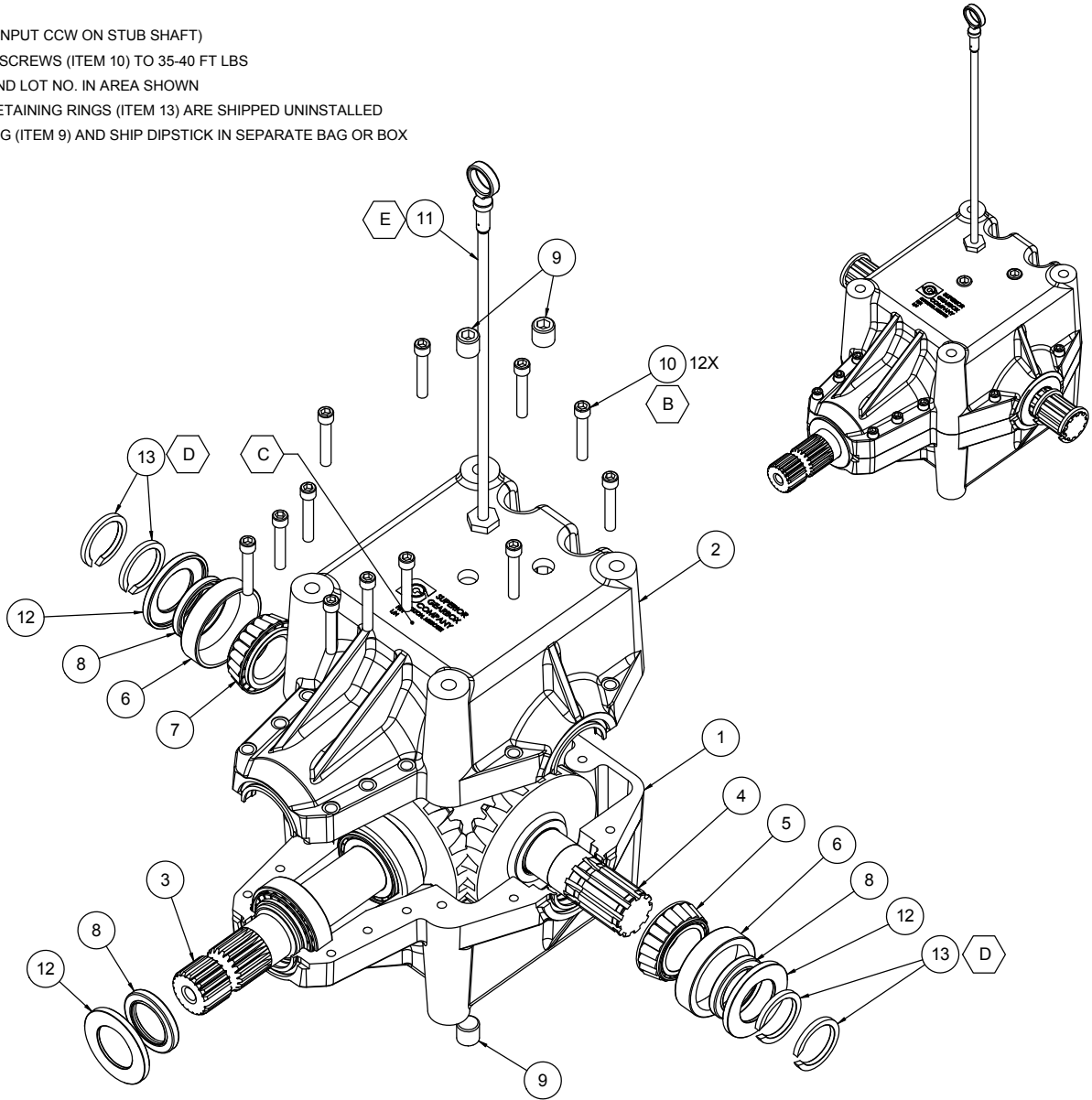

ITEM NO.	PART NUMBER	DESCRIPTION	QTY.
1	903-18383	HSG, MACH TAP R800 STR GRD GR	1
2	903-18384	HSG, MACH R800 THRU STR GRD	1
3	903-18385	ASSY, SHAFT/GEAR R600	1
4	903-18386	ASSY, SHAFT/GEAR	2
5	901-01150	BRG, CONE TK#25581 1.750	1
6	901-01152	BRG, CUP TK#25520 3.265	2
7	901-01328	BRG, CONE TK#25580 1.750	1
8	901-09125	SEAL, 1.75-2.437-.312 (R) TC	3
9	905-03078	PLUG, 1/2-14 NPT SCHD W/3M	4
10	900-03033	BOLT, 3/8-16 X 2.25 SHCS	12
11	903-18225	DIPSTICK, R800 1/2-14 NPT	1
12	901-09233	GUARD, SEAL (OD3.00 ID 1.745)	3
13	900-39030	RETAINING RING, EXT 1.750 SHFT	4
	903-15575	COMPLETE GEARBOX - SUPERIOR MODEL R800 (1:1 RATIO)	

## NOTES :

# BOLT TORQUE CHART

## SAE Series Torque Chart

Always tighten hardware to these values unless a different torque value or tightening procedure is listed for a specific application. Fasteners must always be replaced with the same grade as specified in the manual parts list.

Make sure fastener threads are clean and you properly start thread engagement.

**SAE Bolt Head Identification**

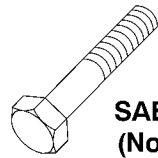

**SAE Grade 2  
(No Dashes)**

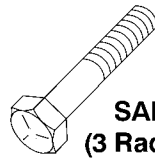

**SAE Grade 5  
(3 Radial Dashes)**

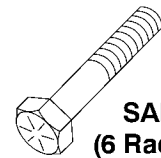

**SAE Grade 8  
(6 Radial Dashes)**

Ⓐ Diameter (Inches)	Wrench Size	MARKING ON HEAD					
		SAE 2		SAE 5		SAE 8	
		Lbs.-Ft.	(N-m)	Lbs.-Ft.	(N-m)	Lbs.-Ft.	(N-m)
1/4"	7/16"	6	(8)	10	(13)	14	(18)
5/16"	1/2"	12	(17)	19	(26)	27	(37)
3/8"	9/16"	23	(31)	35	(47)	49	(67)
7/16"	5/8"	36	(48)	55	(75)	78	(106)
1/2"	3/4"	55	(75)	85	(115)	120	(163)
9/16"	13/16"	78	(106)	121	(164)	171	(232)
5/8"	15/16"	110	(149)	170	(230)	240	(325)
3/4"	1-1/8"	192	(261)	297	(403)	420	(569)
7/8"	1-5/16"	306	(416)	474	(642)	669	(907)
1"	1-1/2"	350	(475)	680	(925)	1020	(1383)
1-1/8"	1-11/16"	450	(610)	885	(1200)	<p>Bolt Diameter</p>	
1-1/4"	1-7/8"	600	(815)	1255	(1700)		
1-3/8"	2-1/16"	675	(915)	1620	(2200)		
1-1/2"	2-1/4"	920	(1250)	2200	(2900)		

## Metric Series Torque Chart

Use only metric tools on metric hardware. Always tighten hardware to these values unless a different torque value or tightening procedure is listed for a specific application. Fasteners must always be replaced with the same grade.

Make sure fastener threads are clean and you properly start thread engagement.

Ⓐ Diameter & Thread Pitch (Millimeters)	Wrench Size	COARSE THREAD				FINE THREAD				Ⓐ Diameter & Thread Pitch (Millimeters)
		MARKING ON HEAD				MARKING ON HEAD				
		Metric 8.8		Metric 10.9		Metric 8.8		Metric 10.9		
		N-m	Lbs.-Ft.	N-m	Lbs.-Ft.	N-m	Lbs.-Ft.	N-m	Lbs.-Ft.	
6x1.0	10 mm	8	6	11	8	8	6	11	8	6x1.0
8x1.25	13 mm	20	15	27	20	21	16	29	22	8x1.0
10x1.5	16 mm	39	29	54	40	41	30	57	42	10x1.25
12x1.75	18 mm	68	50	94	70	75	55	103	76	12x1.25
14x2.0	21 mm	109	80	151	111	118	87	163	120	14x1.5
16x2.0	24 mm	169	125	234	173	181	133	250	184	16x1.5
18x2.5	27 mm	234	172	323	239	263	194	363	268	18x1.5
20 x 2.5	30 mm	330	244	457	337	367	270	507	374	20x1.5
22 x 2.5	34 mm	451	332	623	460	495	365	684	505	22 x 1.5
24 x 3.0	36 mm	571	421	790	583	623	459	861	635	24 x 2.0
30 x 3.0	46 mm	1175	867	1626	1199	1258	928	1740	1283	30 x 2.0

**Metric Bolt Head Identification**

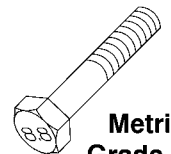

**Metric Grade 8.8**

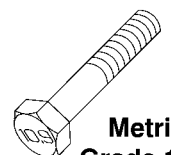

**Metric Grade 10.9**

## Typical Washer Installations

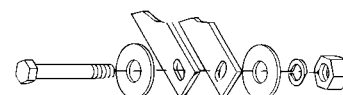
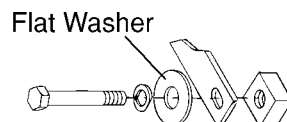
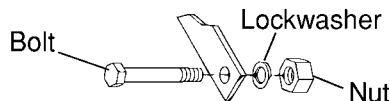

8/9/00

# BOLT SIZE CHART

NOTE: Chart shows bolt thread sizes and corresponding head (wrench) sizes for standard SAE and Metric Bolts.

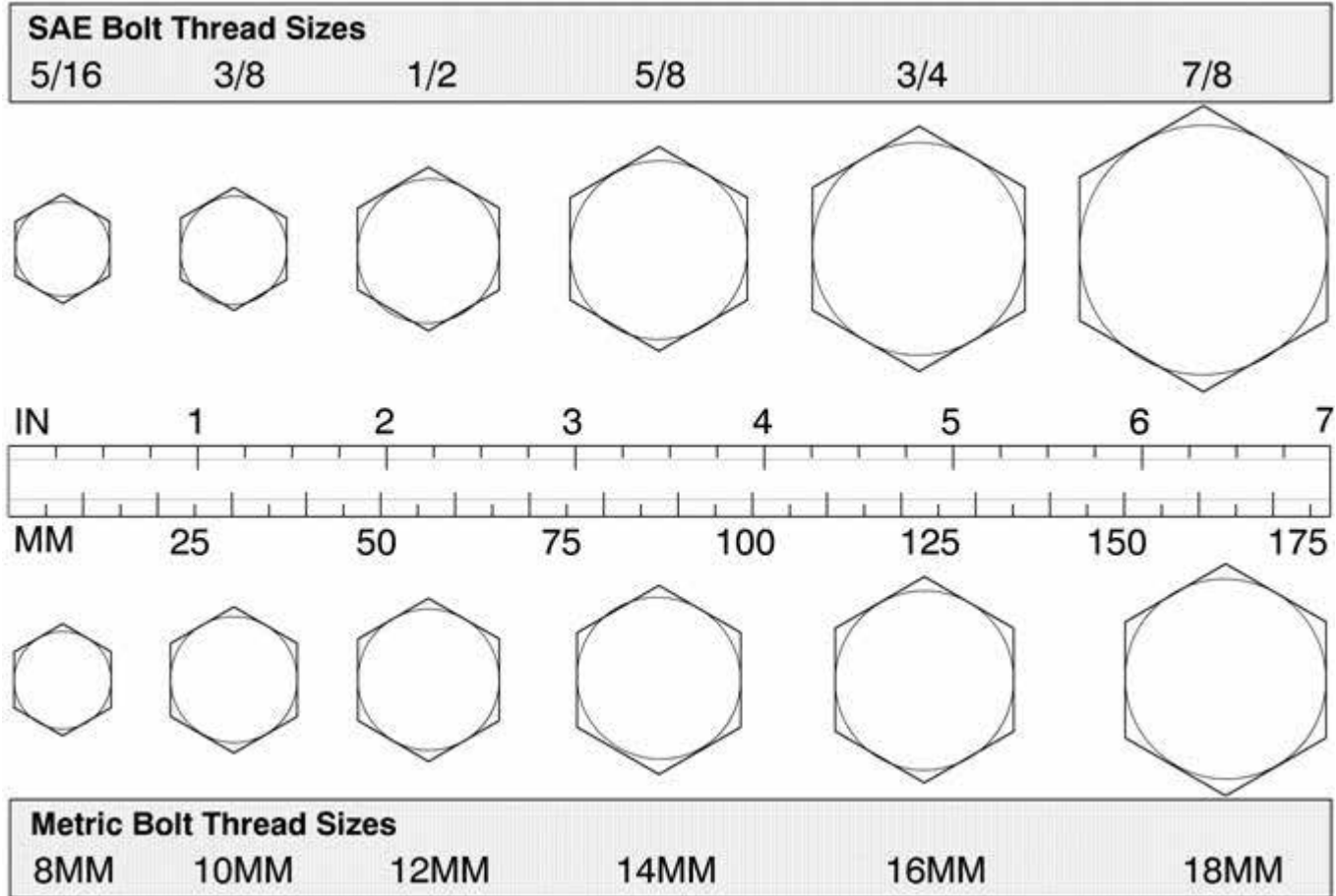

## ABBREVIATIONS

AG .....Agriculture  
 ATF .....Automatic Transmission Fluid  
 BSPP ..... British Standard Pipe Parallel  
 BSPTM ..... British Standard Pipe Tapered Male  
 CV ..... Constant Velocity  
 CCW ..... Counter-Clockwise  
 CW ..... Clockwise  
 F ..... Female  
 GA ..... Gauge  
 GR (5, etc.) ..... Grade (5, etc.)  
 HHCS ..... Hex Head Cap Screw  
 HT ..... Heat Treated  
 JIC ..... Joint Industry Council 37° Degree Flare  
 LH ..... Left Hand  
 LT ..... Left  
 m ..... Meter  
 mm ..... Millimeter  
 M ..... Male  
 MPa ..... Mega Pascal  
 N ..... Newton

NC ..... National Coarse  
 NF ..... National Fine  
 NPSM ..... National Pipe Straight Mechanical  
 NPT ..... National Pipe Tapered  
 NPT SWF ..... National Pipe Tapered Swivel Female  
 ORBM ..... O-Ring Boss - Male  
 P ..... Pitch  
 PBY ..... Power Beyond  
 psi ..... Pounds per Square Inch  
 PTO ..... Power Take Off  
 QD ..... Quick Disconnect  
 RH ..... Right Hand  
 ROPS ..... Roll Over Protective Structure  
 RPM ..... Revolutions Per Minute  
 RT ..... Right  
 SAE ..... Society of Automotive Engineers  
 UNC ..... Unified Coarse  
 UNF ..... Unified Fine  
 UNS ..... Unified Special

## 2008 & OLDER MODELS WINDROW SHREDDER FRAME COMPONENTS

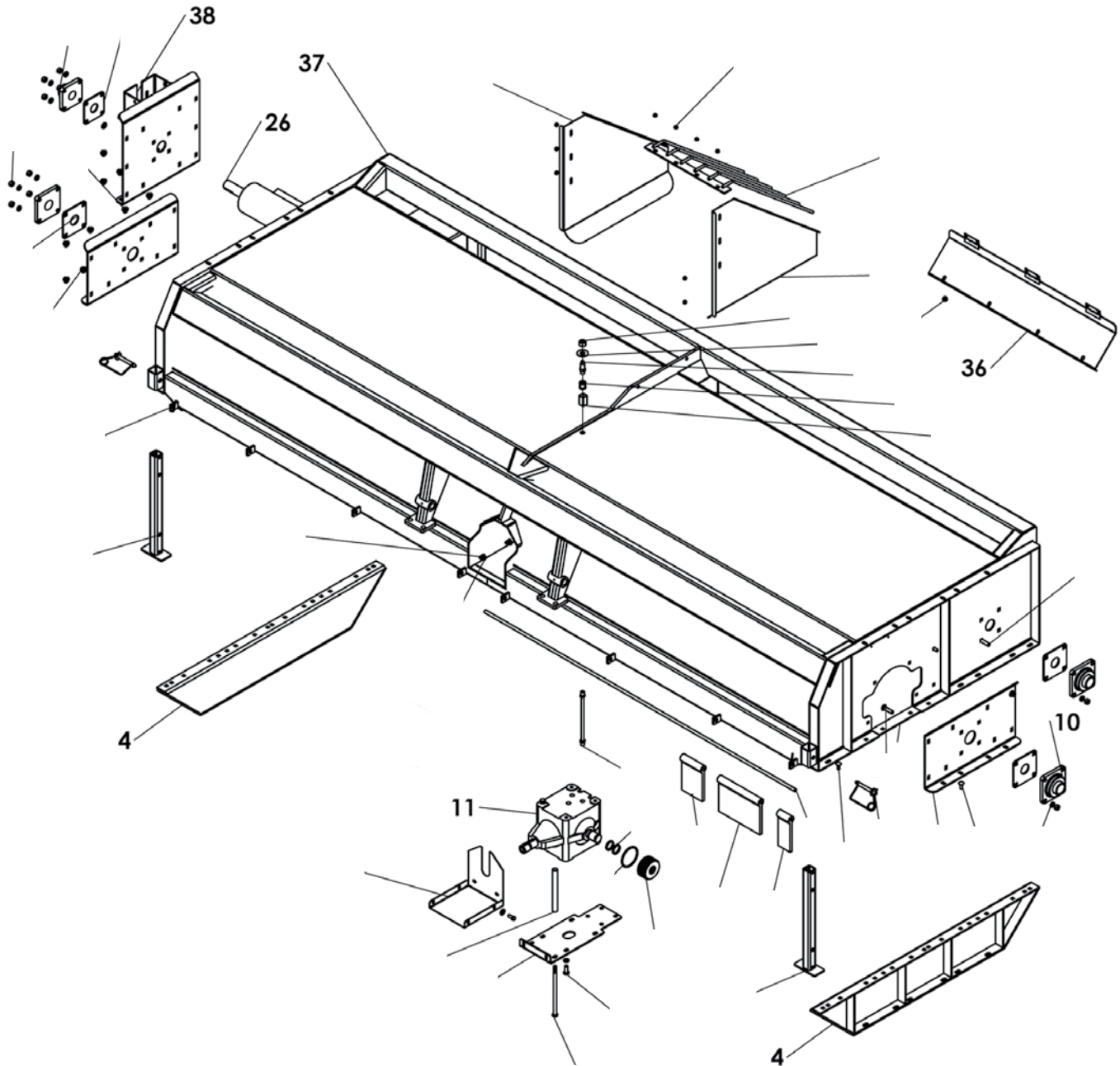

ITEM NO.	PART NUMBER	DESCRIPTION	QTY.
4	507-2-0156	SKID PLATE WELD	2
10	901-01311	BEARING - UCF 211-35 2.19 4-BOLT	3
11	903-15566	G-BOX - SUPERIOR MODEL R800 (1.5 : 1 GEAR RATIO)	1
26	507-2-0213	AUGER WELD - 15' WINDROW - LH	1
	507-2-0215	AUGER WELD - 20' WINDROW - LH	
36	507-2-0209	DOOR WELD - TROUGH	2
37	507-2-0211	15' WINDROW BODY WELD - GEAR DRIVE - LH	1
	507-2-0210	20' WINDROW BODY WELD - GEAR DRIVE - LH	
38	507-2-0214	BEARING PLATE WELD - AUGER	1



## 2008 & OLDER MODELS AUGER DRIVE COMPONENTS

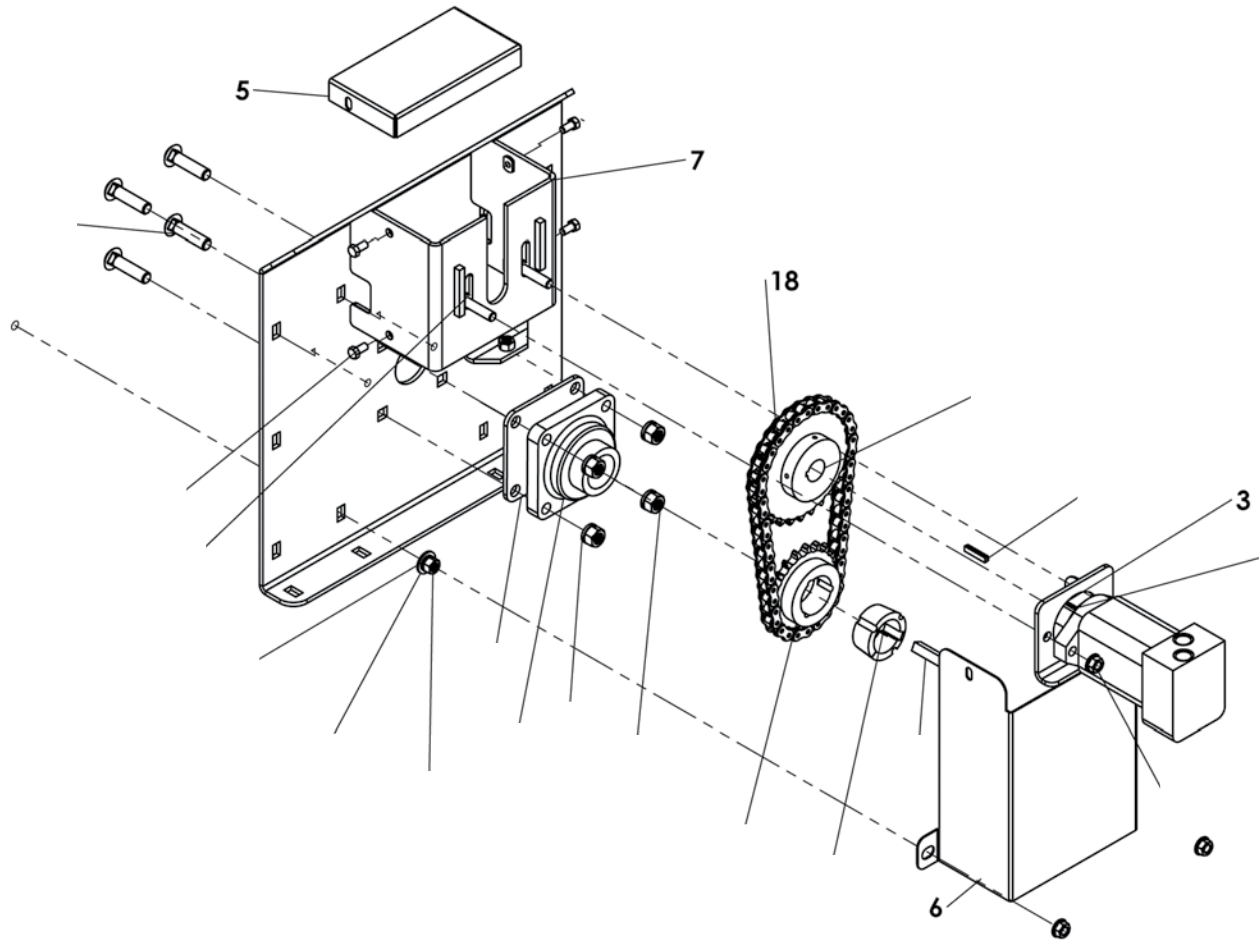

ITEM NO.	PART NUMBER	DESCRIPTION	QTY.
3	700-3-0894	MOUNT PLATE - HYD MOTOR	1
5	507-3-0275	TOP SHIELD - HYD MOTOR	1
6	507-3-0276	LOWER SHIELD - HYD MOTOR	1
7	507-2-0214	BEARING PLATE WELD - AUGER	1
18	507-3-0386	ROLLER CHAIN - #60-1 X 46 LINKS +CONN LINK & HALF LINK	1

## 2008 & OLDER MODELS 3-POINT HITCH COMPONENTS

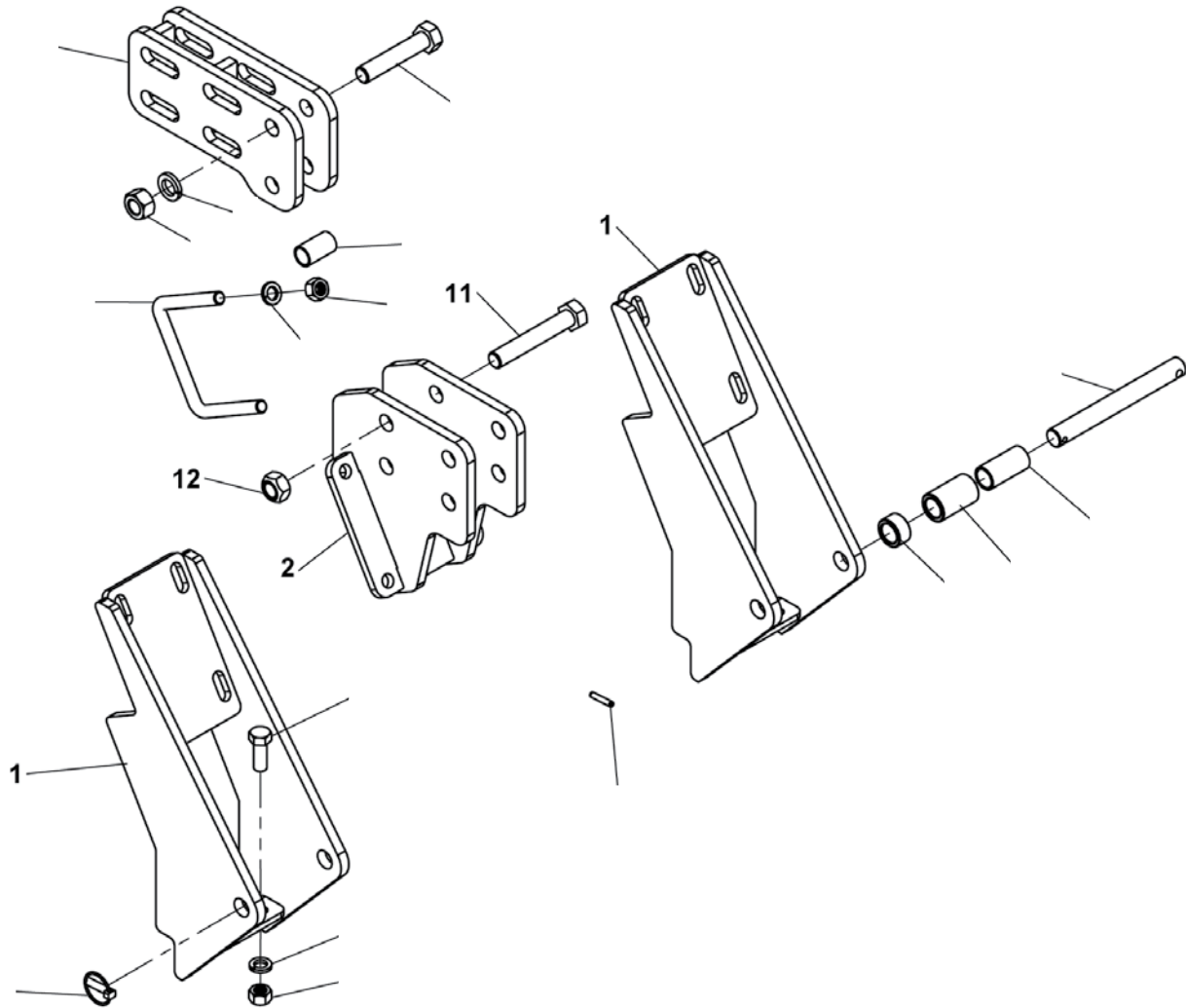

ITEM NO.	PART NUMBER	DESCRIPTION	QTY.
1	507-2-0013	LOWER 3-PT HITCH WELD	2
2	507-2-0015	UPPER 3-PT MOUNT	1
11	900-01535	BOLT HEX HEAD 1 NC X 6, GR5 ZP	4
12	900-06514	NUT, TOP LOCK 1 NC	4

## 2008 & OLDER MODELS PULL TYPE HITCH COMPONENTS

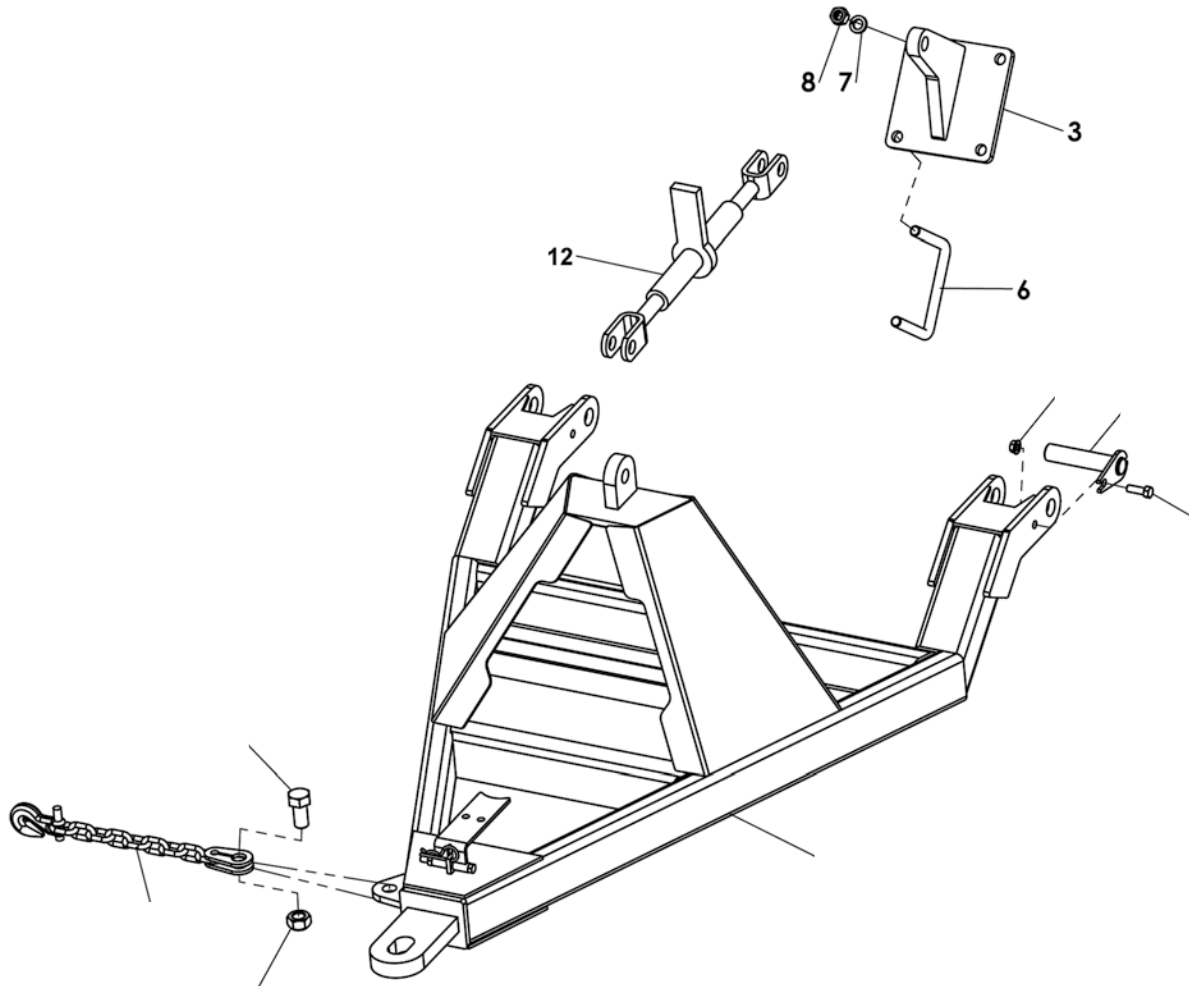

ITEM NO.	PART NUMBER	DESCRIPTION	QTY.
3	507-2-0033	TOP EAR WELD	1
6	200-3-0024	U-BOLT 3/4 NC X 6 X 5.5 X 1.5, GR5 ZP	2
7	900-11017	WASHER, LOCK 3/4	4
8	900-06015	NUT, HEX HEAD 3/4 NC	4
12	905-23014	RATCHET JACK HEAVY DUTY	1

**2008 & OLDER MODELS  
RIGID STRUT - DUAL (LARGE WHEELS)**

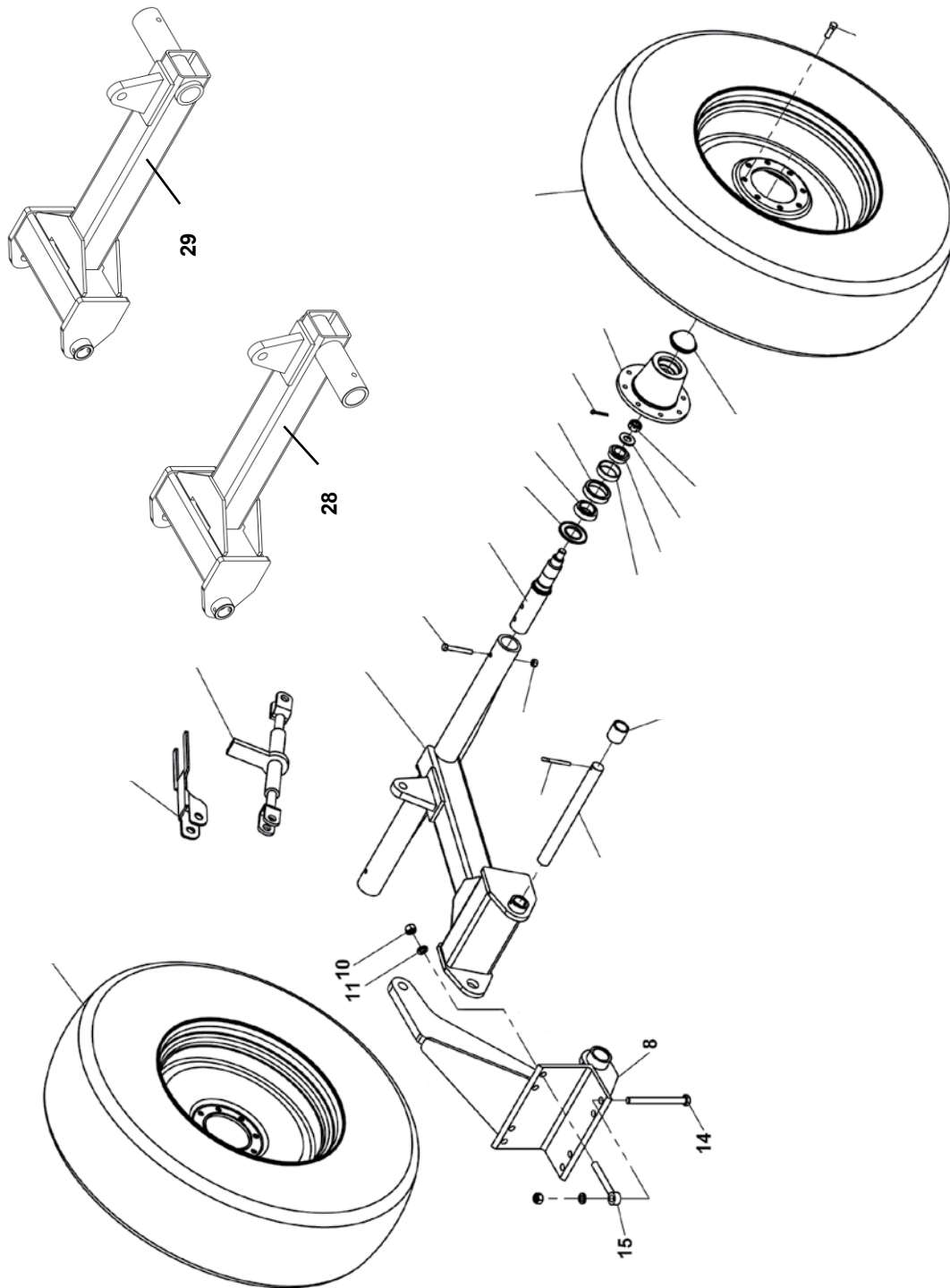

ITEM NO.	PART NUMBER	DESCRIPTION	QTY.
8	507-2-0235	MOUNTING ANGLE WELDMENT	1
10	900-06015	NUT, HEX HEAD 3/4 NC	8
11	900-11017	WASHER, LOCK 3/4	8
14	900-01437	BOLT, HEX HEAD 3/4 NC X 8-1/2, GR5 ZP	4
15	900-03463	BOLT, EYE 3/4 NC, GR5 ZP	4

**2008 & OLDER MODELS  
RIGID STRUT - DUAL (SMALL WHEELS)**

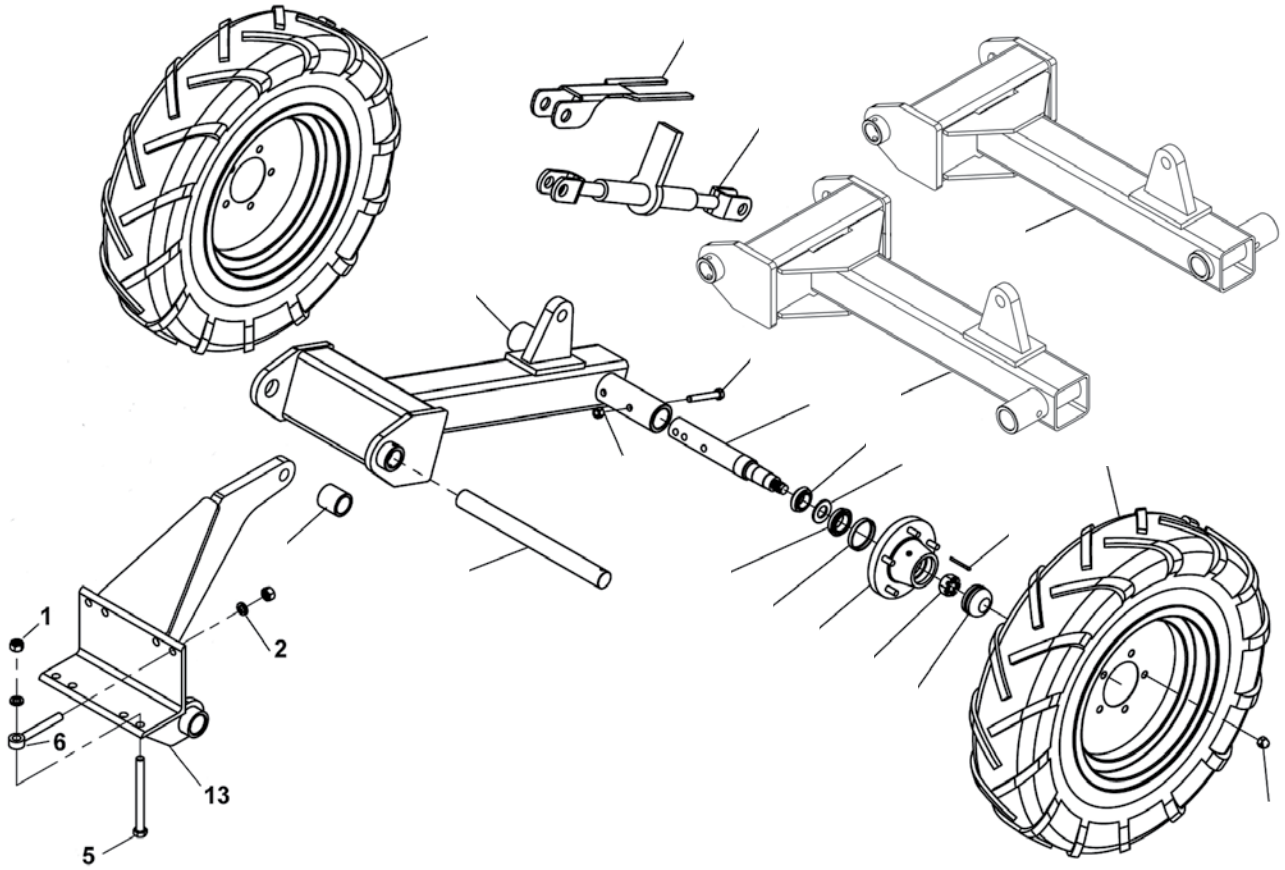

<b>ITEM NO.</b>	<b>PART NUMBER</b>	<b>DESCRIPTION</b>	<b>QTY.</b>
1	900-06015	NUT, HEX HEAD 3/4 NC	8
2	900-11017	WASHER, LOCK 3/4	8
5	900-01437	BOLT, HEX HEAD 3/4 NC X 8-1/2, GR5 ZP	4
6	900-03463	BOLT, EYE 3/4 NC, GR5 ZP	4
13	507-2-0235	MOUNTING ANGLE WELDMENT	1

**2008 & OLDER MODELS  
WEASLER PULL-TYPE PTO SHAFT  
WITH TORQMASTER CLUTCH**

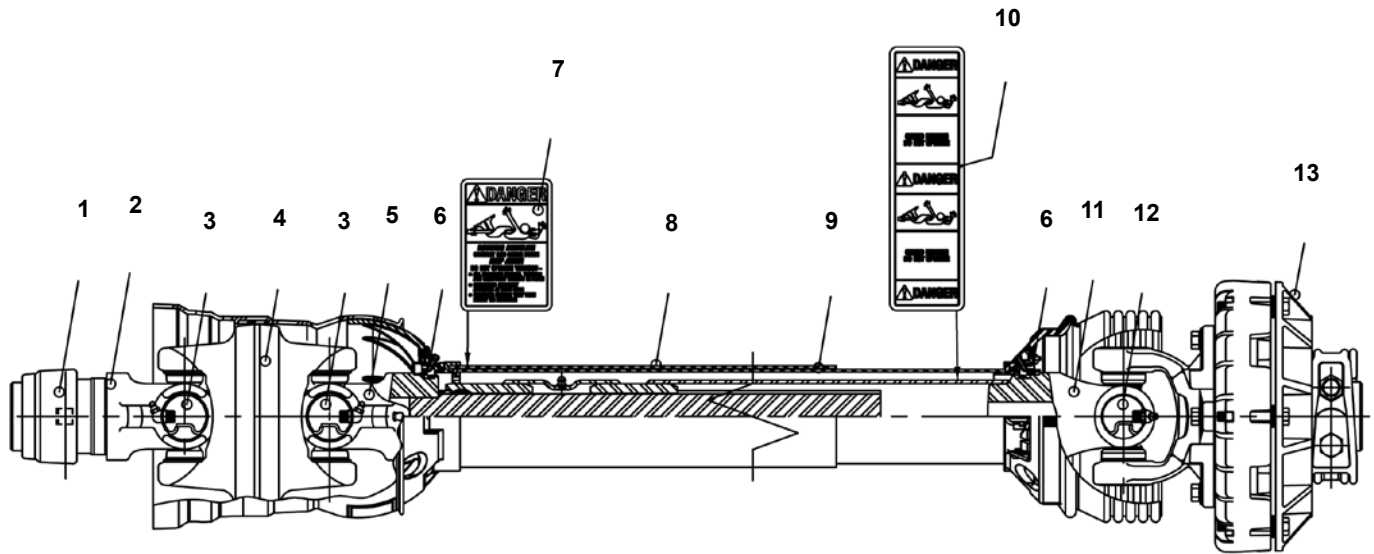

ITEM NO.	PART NUMBER	DESCRIPTION	QTY.
1	903-18106	SAFETY SLIDE LOCK REPAIR KIT 1-3/8"	1
	903-17772	SAFETY SLIDE LOCK REPAIR KIT 1-3/4"	1
2	903-17733	SAFETY SLIDE LOCK YOKE ASSEMBLY 1-3/8"	1
	903-18121	SAFETY SLIDE LOCK YOKE ASSEMBLY 1-3/4"	1
3	903-17737	CAT 6 CROSS & BEARING KIT	2
4	903-17739	CENTER HOUSING ASSEMBLY	1
5	903-17908	YOKE & SHAFT	1
6	903-17774	NYLON REPAIR KIT	2
7	903-17455	SAFETY SIGN	1
8	903-18057	OUTER GUARD	1
9	903-17910	INNER GUARD	1
10	903-17456	SAFETY SIGN	1
11	903-17909	YOKE, TUBE, & SLIP SLEEVE	1
12	903-17239	55R CROSS & BEARING KIT	1
13	903-18303	FRICTION OVER RUNNING CLUTCH ASSEMBLY	1
	903-18283	GUARD SET	
	903-18220	CV SLIP CLUTCH PTO, 1-3/8", COMPLETE	
	903-18221	CV SLIP CLUTCH PTO, 1-3/4", COMPLETE	

## 2008 & OLDER MODELS

### WEASLER 2-POINT & 3-POINT PTO SHAFT WITH TORQMASTER CLUTCH

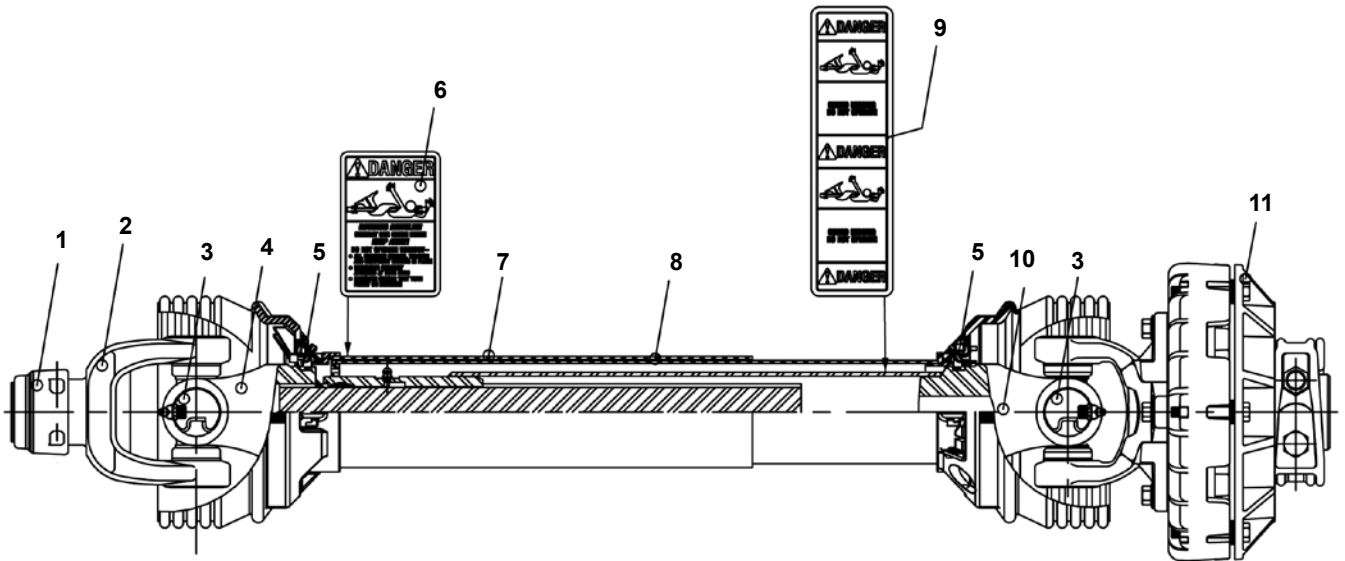

ITEM NO.	PART NUMBER	DESCRIPTION	QTY.
1	903-17772	SAFETY SLIDE LOCK / AUTO-LOCK REPAIR KIT	1
2	903-17418	SAFETY SLIDE LOCK YOKE ASSEMBLY 1-3/4"	1
3	903-17239	55R CROSS & BEARING KIT	2
4	903-17613	YOKE & SHAFT 26.8 CENTER-END	
5	903-17774	NYLON REPAIR KIT (NS)	2
6	903-17455	SAFETY SIGN	1
7	903-17614	OUTER GUARD, 24" LONG BELL	1
	903-18073	OUTER GUARD, 31" LONG BELL	1
8	903-17725	INNER GUARD	1
9	903-17456	SAFETY SIGN	1
10	903-17724	YOKE, TUBE, & SLIP SLEEVE	1
11	903-18303	FRICITION OVER RUNNING CLUTCH ASSEMBLY	1
	903-18290	GUARD SET	
	903-18218	SLIP CLUTCH PTO, 1-3/8", COMPLETE	
	903-18219	SLIP CLUTCH PTO, 1-3/4", COMPLETE	

**2008 & OLDER MODELS  
WEASLER TORQMASTER CLUTCH COMPONENTS**

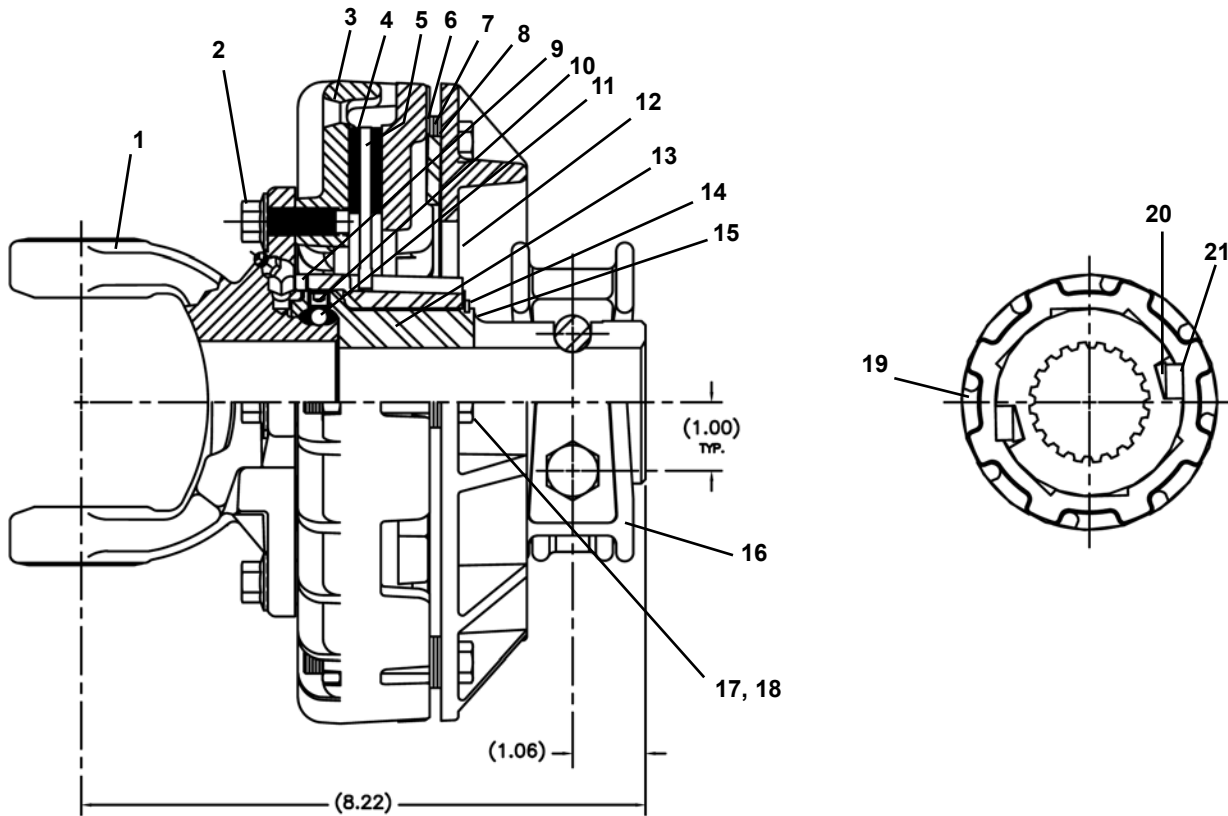

ITEM NO.	PART NUMBER	DESCRIPTION	QTY.
1	903-18191	YOKE	1
	903-18226	OVERRUNNING REPAIR KIT, (2, 6, 7, 8, 9)	
2	900-03054	BOLT, M10 X 1.50 LG, CLASS 10.9	4
3	903-18227	HOUSING	1
4	903-18175	FRICTION DISC	2
5	903-18174	SEPARATOR PLATE	
6	903-18228	PRESSURE PLATE	1
7	905-14019	SPRING	1
8	900-11236	WASHER, M8 NARROW	24
9	900-03053	WAVE SPRING	1
10	903-18154	SET SCREW, .315-18 X .25 LG	1
11	903-18230	BALL, .250, GRADE 5	31
12	903-18229	COMPRESSION PLATE	1
13	903-18232	OVERRUNNING INNER HUB	1
14	903-18167	WASHER	
15	903-18168	RETAINING RING	1
16	903-18233	CLAMP	1
17	900-03053	BOLT, M8 X 1.25 X .60 LG, CLASS 10.9	6
18	900-06548	NUT, M8 X 1.25	6
19	903-18231	OVERRUNNING HUB	1
20	903-18170	LEAF SPRING	2
21	903-18171	OVERRUNNING KEY	2
	903-18234	YOKE & HUB ASM.	
	903-18235	FRICTION PACK	
	903-18303	FRICTION OVERRUNNING CLUTCH ASSEMBLY	



## 2008 & OLDER MODELS CENTER DRIVE GEARBOX

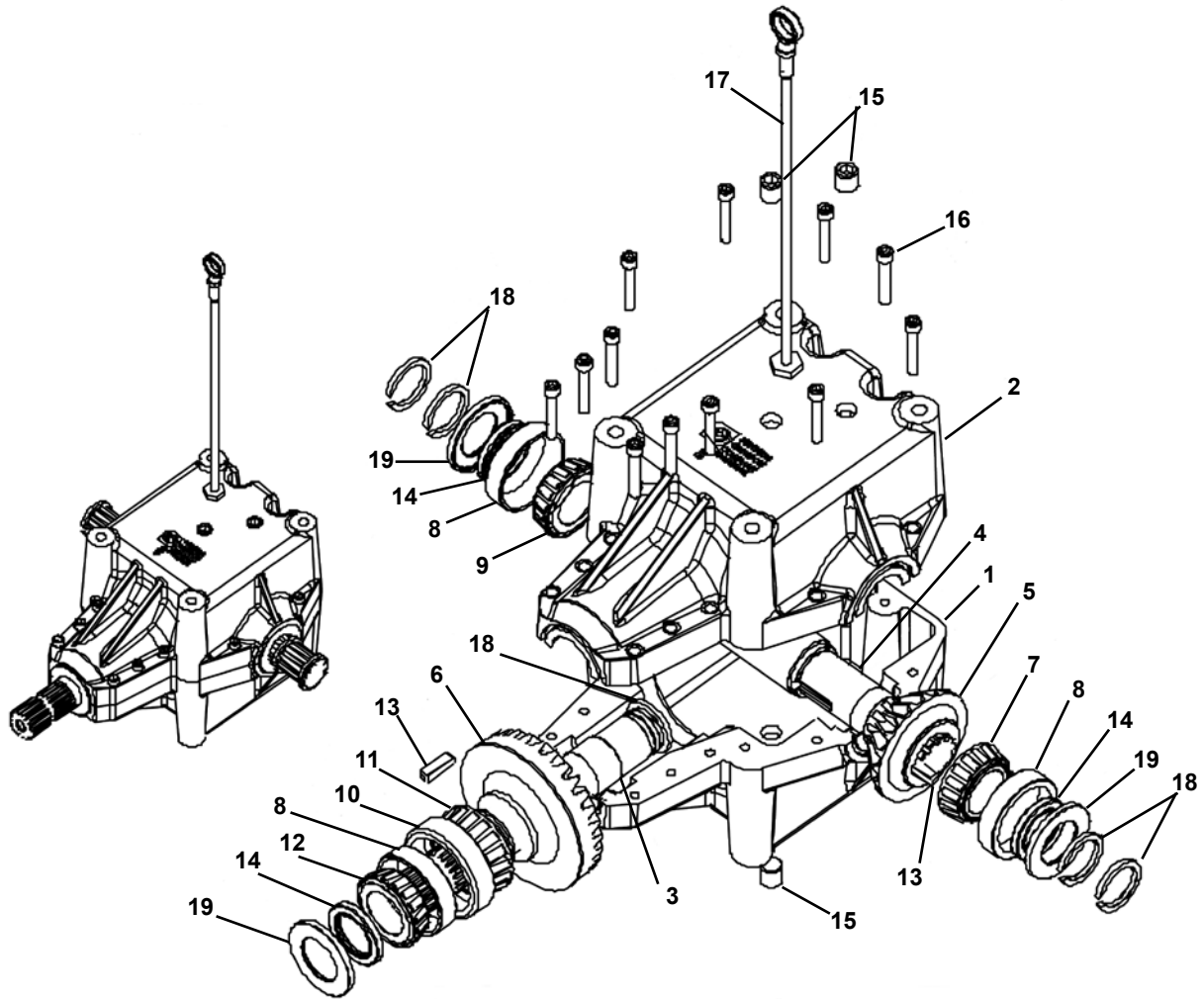

ITEM NO.	PART NUMBER	DESCRIPTION	QTY.
1	903-18222	HOUSING, SEAL GUARD	1
2	903-18223	CASTING, MACH R800 THRU	1
3	903-15567	SHAFT, STUB R600 KEYED 20T	1
4	903-15568	SHAFT, CROSS R600 KEYED 2X 10T	1
5	903-15321	GEAR R6 1.5 .375 KEYED 20T	1
6	903-15320	GEAR R6 1.5 .375 KEYED 30T	1
7	901-01150	BEARING, CONE 1.750 VN-25581	1
8	901-01152	BEARING, CUP 3.2650 VN-25520	3
9	901-01328	BEARING, CONE 25580	1
10	901-01153	BEARING, CUP 3.6718 VN-3720	1
11	901-09230	BEARING, CONE TMKN #3777	1
12	901-09231	BEARING, CONE TMKN #25592	1
13	903-15374	KEY, 3/8 X 3/8, 1.435	2
14	901-09125	SEAL, 1.750-2.437-.312 (R) TC	3
15	905-03078	PLUG, 1/2-14NPT SCHD W/3M	4
16	900-03033	BOLT, 3/8-16 X 2.25 SHCS	12
17	903-18225	DIPSTICK, R800 1/2-14NPT	1
18	900-39030	RETAINING RING, EXT 1.750 SHFT	5
19	901-09233	GUARD, SEAL (OD3.00 ID1.745)	3
	903-15566	COMPLETE GEARBOX - SUPERIOR R800 (1:1.5 RATIO)	

## NUMERICAL INDEX *(Continued)*

<b>PART NO.</b>	<b>PAGE</b>	<b>PART NO.</b>	<b>PAGE</b>	<b>PART NO.</b>	<b>PAGE</b>	<b>PART NO.</b>	<b>PAGE</b>
100-3-3331	49	507-1-0003	51	507-2-0200	48	700-3-0894	49
100-3-3676	49	507-2-0013	50	507-2-0209	47	900-01005	60
200-2-0553	50	507-2-0015	50	507-2-0210	47	900-01021	53
200-3-0024	50	507-2-0020	50	507-2-0211	47	900-01021	55
200-3-0024	51	507-2-0021	47	507-2-0213	47	900-01105	47
200-3-0151	50	507-2-0027	51	507-2-0214	47	900-01105	49
200-3-0959	50	507-2-0028	53	507-2-0214	49	900-01223	47
200-3-0960	50	507-2-0028	55	507-2-0215	47	900-01225	47
200-3-0961	50	507-2-0033	51	507-2-0220	48	900-01225	51
500-1-0017	59	507-2-0075	48	507-2-0221	48	900-01229	49
500-2-0157	53	507-2-0076	48	507-2-0225	60	900-01241	57
500-2-0157	55	507-2-0079	48	507-2-0235	57	900-01241	58
500-2-0157	58	507-2-0080	48	507-2-0235	58	900-01341	47
500-2-0158	53	507-2-0083	58	507-3-0023	47	900-01393	47
500-2-0158	58	507-2-0093	58	507-3-0046	47	900-01403	50
500-2-0161	58	507-2-0096	48	507-3-0120	47	900-01437	53
500-2-0684	51	507-2-0097	48	507-3-0121	47	900-01437	55
500-2-1023	57	507-2-0099	55	507-3-0128	47	900-01437	57
500-3-0136	53	507-2-0101	53	507-3-0179	53	900-01437	58
500-3-0136	55	507-2-0101	55	507-3-0179	55	900-01511	51
500-3-0136	58	507-2-0102	53	507-3-0180	53	900-01531	50
500-3-0338	47	507-2-0102	55	507-3-0180	55	900-01535	50
500-3-0928	53	507-2-0103	53	507-3-0218	60	900-01695	47
500-3-0928	55	507-2-0103	55	507-3-0224	47	900-01750	47
500-3-0990	47	507-2-0105	53	507-3-0237	60	900-01752	47
500-3-0990	49	507-2-0106	53	507-3-0238	60	900-01788	47
500-3-1151	57	507-2-0107	55	507-3-0242	47	900-01788	49
500-3-1151	58	507-2-0108	60	507-3-0268	47	900-01792	48
500-3-1328	57	507-2-0149	47	507-3-0275	49	900-03033	64
500-3-1328	58	507-2-0156	47	507-3-0276	49	900-03053	63
500-3-1696	60	507-2-0157	47	507-3-0342	47	900-03053	63
500-3-2091	60	507-2-0181	57	507-3-0356	47	900-03054	63
500-3-2202	57	507-2-0184	58	507-3-0357	47	900-03463	53
500-3-2202	58	507-2-0186	58	507-3-0372	47	900-03463	55
505-3-0005	48	507-2-0187	57	507-3-0386	49	900-03463	57
505-3-0405	48	507-2-0188	57	507-3-0394	47	900-03463	58
505-3-0868	47	507-2-0193	47	700-2-0165	57	900-06009	47
505-3-1089	47	507-2-0194	48	700-2-0167	57	900-06009	49
505-3-1097	47	507-2-0196	48	700-2-0168	57	900-06013	47
507-1-0002	50	507-2-0199	48	700-3-0143	57	900-06013	49

## NUMERICAL INDEX *(Continued)*

<b>PART NO.</b>	<b>PAGE</b>	<b>PART NO.</b>	<b>PAGE</b>	<b>PART NO.</b>	<b>PAGE</b>	<b>PART NO.</b>	<b>PAGE</b>
900-06015	50	900-11035	47	901-09002	55	903-17910	61
900-06015	51	900-11035	49	901-09002	58	903-18057	61
900-06015	53	900-11039	47	901-09125	64	903-18073	62
900-06015	55	900-11236	63	901-09126	47	903-18106	61
900-06015	57	900-16031	53	901-09215	57	903-18121	61
900-06015	58	900-16031	55	901-09230	64	903-18154	63
900-06017	47	900-23043	47	901-09231	64	903-18167	63
900-06019	50	900-23045	53	901-09233	64	903-18168	63
900-06060	57	900-23045	55	903-03062	49	903-18170	63
900-06062	53	900-23045	58	903-03089	49	903-18171	63
900-06062	55	900-23064	57	903-08450	49	903-18174	63
900-06062	58	900-23084	57	903-11062	49	903-18175	63
900-06139	47	900-25012	50	903-11094	49	903-18191	63
900-06139	60	900-31045	47	903-15320	64	903-18218	62
900-06143	47	900-35000	60	903-15321	64	903-18219	62
900-06143	49	900-39030	47	903-15374	64	903-18220	61
900-06143	51	900-39030	64	903-15566	47	903-18221	61
900-06145	47	900-42054	47	903-15566	64	903-18222	64
900-06145	48	901-01015	53	903-15567	64	903-18223	64
900-06270	53	901-01015	55	903-15568	64	903-18225	64
900-06270	55	901-01015	58	903-17239	61	903-18226	63
900-06496	53	901-01023	53	903-17239	62	903-18227	63
900-06496	55	901-01023	55	903-17418	62	903-18228	63
900-06496	60	901-01023	58	903-17455	61	903-18229	63
900-06504	57	901-01150	64	903-17455	62	903-18230	63
900-06504	58	901-01152	57	903-17456	61	903-18231	63
900-06514	50	901-01152	64	903-17456	62	903-18232	63
900-06514	51	901-01153	64	903-17613	62	903-18233	63
900-06548	63	901-01259	53	903-17614	62	903-18234	63
900-11013	47	901-01259	55	903-17724	62	903-18235	63
900-11013	49	901-01261	53	903-17725	62	903-18283	61
900-11015	47	901-01261	55	903-17733	61	903-18284	61
900-11015	49	901-01282	47	903-17737	61	903-18285	61
900-11017	50	901-01282	49	903-17739	61	903-18286	61
900-11017	51	901-01311	47	903-17772	61	903-18287	61
900-11017	53	901-01324	57	903-17772	62	903-18288	61
900-11017	55	901-01325	57	903-17774	61	903-18289	61
900-11017	57	901-01326	57	903-17774	62	903-18290	62
900-11017	58	901-01328	64	903-17908	61	903-18291	62
900-11021	50	901-09002	53	903-17909	61	903-18292	62

# NUMERICAL INDEX *(Continued)*

PART NO.	PAGE	PART NO.	PAGE	PART NO.	PAGE	PART NO.	PAGE
903-18293	62	905-19150	59				
903-18294	62	905-19171	59				
903-18295	62	905-19175	59				
903-18296	62	905-19193	59				
903-18303	61	905-19194	59				
<hr/>							
903-18303	63	905-19203	59				
903-18303	62	905-19210	59				
904-01154	60	905-19224	47				
904-01155	60	905-19230	59				
904-05223	49	905-21290	59				
<hr/>							
905-01189	47	905-21305	59				
905-03078	64	905-21398	59				
905-03114	59	905-21407	59				
905-03163	59	905-23014	51				
905-03199	59	905-23014	53				
<hr/>							
905-03211	59	905-23014	55				
905-03220	59	905-23014	57				
905-03244	59	905-23014	58				
905-07091	59						
905-07123	51						
<hr/>							
905-09003	53						
905-09003	55						
905-09003	58						
905-09009	53						
905-09009	55						
<hr/>							
905-09009	58						
905-09011	53						
905-09011	55						
905-09011	58						
905-09039	57						
<hr/>							
905-09067	57						
905-09068	53						
905-09068	55						
905-09068	58						
905-09135	57						
<hr/>							
905-09136	57						
905-14019	63						
905-15024	53						
905-15024	55						
905-19126	59						

# INDEX

## ASSEMBLY

- All Units, 40
- Assembling 3-Point Components, 40
- Delivery Checklist (Dealer's Responsibility), 7, 39
- Installing Manual Storage Tube, 41
- Installing Pull-Type Hitch, 41
- Installing wheel assembly, 40
- Pre-Delivery Checklist (Dealer's Responsibility), 7, 39
- Preparation, 40
- Safety Light Kit (Non-End Tow), 42

## CHECK LISTS

- Delivery Check List(Dealer's Responsibility), 7, 39
- Pre-Delivery Check List(Dealer's Responsibility), 7, 39
- Pre-Operation Check List(Owner's Responsibility), 13

## GENERAL

- Abbreviations, 65
- Bolt Size Chart, 65
- Bolt Torque Chart, 64
- Check Lists, 7, 39
- General Information, 1
- Introduction, 2
- Product Warranty, 70
- Replacement Parts Warranty, 71
- Table of Contents, 1

## OPERATION, 11

- Additional Equipment, 24
  - Center Divider, 24
  - End Guards & Skids, 24
  - Front Shield Flap, 24
- Attaching Shredder to Tractor, 16
  - 3-point and 2-point models, 16
  - Hydraulics (Center cutter option), 16
  - PTO Driveline, 16
  - Pull-type model, 16
  - Raising Stands, 17
- Breaking-in, 14
- Choosing the Correct Equipment, 13
  - 3-Point Hitch, 14
  - Drawbar clearance (Pull-type models), 14
  - Horsepower, 13
  - Load Sensing Hydraulics, 14
  - Tractor Weight, 13
- Field Operation, 17
  - Ground Speed, 23
  - Hazard Area, 22
  - Setting 3-Point & 2-Point Hitch, 20
  - Setting Operating Height, 19
    - 3-Point hitch models, 19
    - Pull-type models, 19
  - Setting Outer Trailing Wheels, 21
  - Speed vs. Weight Ratio (Table 2), 18
  - Starting the Tractor, 22
  - Stopping the Tractor, 22
  - Transporting the Shredder, 18
  - Turning, 23

## OPERATION (Continued)

- Flail Types, 20
- Pre-Operation Check List (Owner's Responsibility), 13
- Preparing for Operation, 19
  - Flail Height, 19
- Principal Components, 12
- PTO Driveline Dimensions, 15
- Removing the Shredder from the Tractor, 17
- Setting Flail Height, 20, 21
- Storage, 25
- Tractor Horsepower vs. Unit Width (Table 1), 13
- Transporting the Shredder, 18
- Trouble Shooting, 37

## OWNER SERVICE

- Lubrication
  - Lubrication Points, 23

## PARTS INDEX, 43

## SAFETY

- Check Lists
  - Delivery (Dealer's Responsibility), 7, 39
  - Pre-Delivery (Dealer's Responsibility), 7, 39
  - Pre-Operation (Owner's Responsibility), 13
- Field Operation
  - Hazard Area, 22
- Operator Sign-off Record, 10
- Safety & Instructional Decals, 8–9
- Safety-Alert Symbol (Explanation), 2
- Safety Rules, 3
- Transporting the Shredder, 18

## SERVICE & MAINTENANCE

- Acceptable Oil Leakage from Gearbox, 31
- Changing Gearbox Oil, 31
- Lubricants, 26
- Lubrication Schedule, 27
- Lubrication Service Record, 30
- Replacing Flails, 33
- Replacing Rubber Shield Flaps, 33
- Replacing Stub Shaft, 35
- Servicing Modular Friction Clutch, 35
- Servicing Rotors, 34
- Setting Ratchets, 32
- Trouble Shooting, 37
- Wheel Spacing, 32

## TROUBLE SHOOTING, 37

# NOTES

# NOTES

# WARRANTY

Please Enter Information Below and Save For Future Reference.

Date Purchased: \_\_\_\_\_ From (Dealer): \_\_\_\_\_

Model Number: \_\_\_\_\_ Serial Number: \_\_\_\_\_

ALLOWAY STANDARD, d/b/a ALLOWAY, warrants this product to be free from defect in material and workmanship for TWELVE (12) MONTHS COMMENCING ON THE DATE OF DELIVERY OF THE PRODUCT TO THE ORIGINAL PURCHASER.

Under no circumstances will this Warranty apply in the event that the product, in the good faith opinion of ALLOWAY, has been subjected to improper operation, improper maintenance, misuse, or an accident. This Warranty does not apply in the event that the product has been materially modified or repaired by someone other than ALLOWAY, a ALLOWAY authorized dealer or distributor, and/or a ALLOWAY authorized service center; This Warranty does not cover normal wear or tear, or normal maintenance items. This Warranty also does not cover repairs made with parts other than those obtainable through ALLOWAY.

This Warranty is extended solely to the original purchaser of the product. Should the original purchaser sell or otherwise transfer this product to a third party, this Warranty does not transfer to the third party purchaser in any way. There are no third party beneficiaries of this Warranty.

ALLOWAY makes no warranty, express or implied, with respect to tires or other parts or accessories not manufactured by ALLOWAY. Their respective manufacturers, if any, provide warranties for these items, separately. ALLOWAY'S' obligation under this Warranty is limited to, at ALLOWAYS' option, the repair or replacement, free of charge, of the product if ALLOWAY, in its sole discretion, deems it to be defective or in noncompliance with this Warranty. The product must be returned to ALLOWAY with proof of purchase within thirty (30) days after such defect or noncompliance is discovered or should have been discovered, routed through the dealer and distributor from whom the purchase was made, transportation charges prepaid. ALLOWAY shall complete such repair or replacement within a reasonable time after ALLOWAY receives the product. THERE ARE NO OTHER REMEDIES UNDER THIS WARRANTY. THE REMEDY OF REPAIR OR REPLACEMENT IS THE SOLE AND EXCLUSIVE REMEDY UNDER THIS WARRANTY.

THERE ARE NO WARRANTIES, WHICH EXTEND BEYOND THE DESCRIPTION ON THE FACE OF THIS WARRANTY. ALLOWAY MAKES NO OTHER WARRANTY, EXPRESS OR IMPLIED, AND ALLOWAY SPECIFICALLY DISCLAIMS ANY IMPLIED WARRANTY OF MERCHANTABILITY AND/OR ANY IMPLIED WARRANTY OF FITNESS FOR A PARTICULAR PURPOSE.

ALLOWAY shall not be liable for any incidental or consequential losses, damages or expenses, arising directly or indirectly from the product, whether such claim is based upon breach of contract, breach of warranty, negligence, strict liability in tort or any other legal theory. Without limiting the generality of the foregoing, Alloway specifically disclaims any damages relating to (i) lost profits, business, revenues or goodwill; (ii) loss of crops; (iii) loss because of delay in harvesting; (iv) any expense or loss incurred for labor, supplies, substitute machinery or rental; or (v) any other type of damage to property or economic loss.

This Warranty is subject to any existing conditions of supply, which may directly affect ALLOWAYS' ability to obtain materials or manufacture replacement parts.

No agent, representative, dealer, distributor, serviceperson, salesperson, or employee of any company; including without limitation, ALLOWAY, its authorized dealers, distributors, and service centers, is authorized to alter, modify, or enlarge this Warranty.

This Warranty is effective only if the warranty registration card is returned within ten (10) days.

Answers to any questions regarding warranty service and locations may be obtained by contacting:

Alloway  
4230 14<sup>th</sup> Ave.NW  
 Fargo, North Dakota 58102  
701-356-4983





## WARRANTY

ALLOWAY STANDARD, d/b/a ALLOWAY, warrants this product to be free from defect in material and workmanship for a period of One (1) year, ninety (90) days for Service Parts, from the date of delivery of the product to the original purchaser.

Under no circumstances will this Warranty apply in the event that the product, in the good faith opinion of ALLOWAY, has been subjected to improper operation, improper maintenance, misuse, or an accident. This Warranty does not cover normal wear or tear, or normal maintenance items.

This Warranty is extended solely to the original purchaser of the product. Should the original purchaser sell or otherwise transfer this product to a third party, this Warranty does not transfer to the third party purchaser in any way. There are no third party beneficiaries of this Warranty.

ALLOWAY'S' obligation under this Warranty is limited to, at ALLOWAY'S option, the repair or replacement, free of charge, of the product If ALLOWAY, in its sole discretion, deems it, to be defective or in noncompliance with this Warranty. The product must be returned to ALLOWAY with proof of purchase within thirty (30) days after such defect or noncompliance is discovered or should have been discovered, routed through the dealer and distributor from whom the purchase was made, transportation charges prepaid. ALLOWAY shall complete such repair or replacement within a reasonable time after ALLOWAY receives the product. THERE ARE NO OTHER REMEDIES UNDER THIS WARRANTY. THE REMEDY OF REPAIR OR REPLACEMENT IS THE SOLE AND EXCLUSIVE REMEDY UNDER THIS WARRANTY.

THERE ARE NO WARRANTIES WHICH EXTEND BEYOND THE DESCRIPTION ON THE FACE OF THIS WARRANTY. ALLOWAY MAKES NO OTHER WARRANTY, EXPRESS OR IMPLIED, AND ALLOWAY SPECIFICALLY DISCLAIMS ANY IMPLIED WARRANTY OF MERCHANTABILITY AND/ OR ANY IMPLIED WARRANTY OF FITNESS FOR A PARTICULAR PURPOSE.

ALLOWAY shall not be liable for any incidental or consequential losses, damages or expenses, arising directly or indirectly from the product, whether such claim is based upon breach of contract, breach, of warranty, negligence, strict liability in tort or any other legal theory. Without limiting the generality of the foregoing, Alloway specifically disclaims any damages relating to (i) lost profits, business, revenues or goodwill; (ii) loss of crops; (iii) loss because of delay in harvesting; (iv) any expense or loss incurred for labor, supplies, substitute machinery or rental; or (v) any other type of damage to property or economic loss.

This Warranty is subject to any existing conditions of supply, which may directly affect ALLOWAYS' ability to obtain materials or manufacture replacement parts.

No agent, representative, dealer, distributor, service person, salesperson, or employee of any company, including without limitation, ALLOWAY, Its authorized dealers, distributors, and service centers, IS authorized to alter, modify, or enlarge this Warranty.

Answers to any questions regarding warranty service and locations may be obtained by contacting:

Alloway  
4230 14<sup>th</sup> Ave.NW  
Fargo, North Dakota 58102  
701-356-4983



**PART NUMBER**  
**507-3-0431**

**Alloway Equipment  
Company**

4230 14th Ave NW.  
Fargo, ND 58102

877-275-8714 tel

701-356-4985 fax

**alloway** STANDARD