

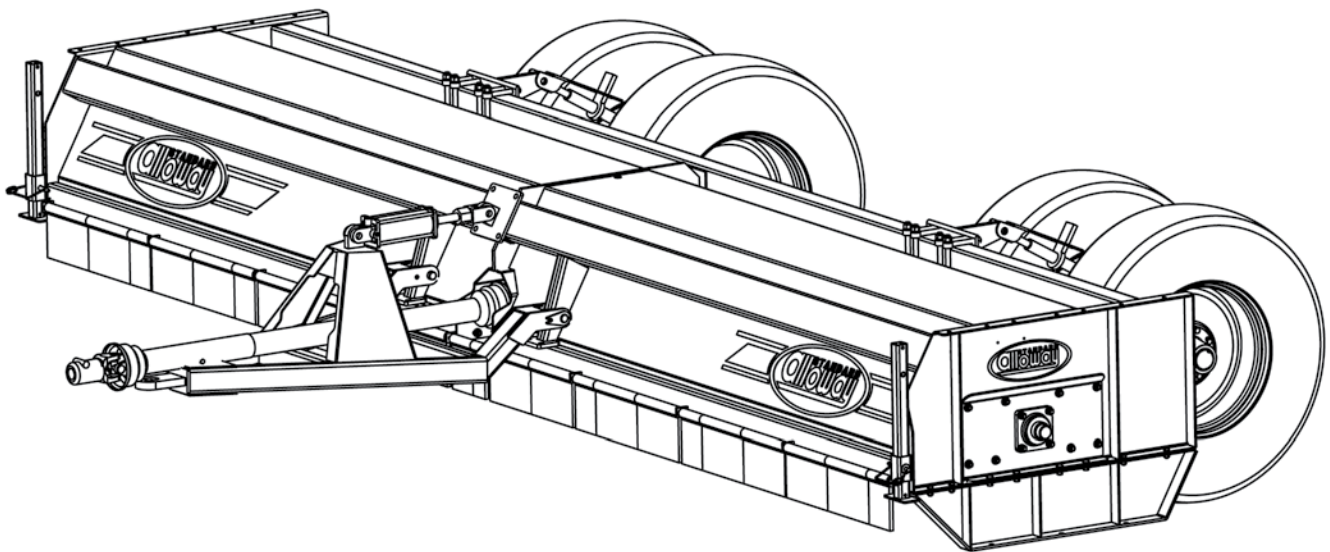

2011

CENTER DRIVE SHREDDER



OPERATOR'S MANUAL

TO THE DEALER:

Assembly and proper installation of this product is the responsibility of the Alloway dealer. Read manual instructions and safety rules. Make sure all items on the Dealer's Pre-Delivery and Delivery Check Lists in the Operator's Manual are completed before releasing equipment to the owner.

The dealer must complete the Warranty Registration included in this manual. Both dealer and customer must sign the registration which certifies that all Dealer Check List items have been completed. The dealer is to return the prepaid postage portion to Alloway, give one copy to the customer, and retain one copy.

Note: Warranty credit is subject to this form being completed and returned.

TO THE OWNER:

Read this manual before operating your Alloway equipment. The information presented will prepare you to do a better and safer job. Keep this manual handy for ready reference. Require all operators to read this manual carefully and become acquainted with all the adjustment and operating procedures before attempting to operate. Replacement manuals can be obtained from your dealer.

The equipment you have purchased has been carefully engineered and manufactured to provide dependable and satisfactory use. Like all mechanical products, it will require cleaning and upkeep. Lubricate the unit as specified. Observe all safety information in this manual and safety decals on the equipment.

For service, your authorized Alloway dealer has trained mechanics, genuine Alloway service parts, and the necessary tools and equipment to handle all your needs.

Use only genuine Alloway service parts. Substitute parts will void the warranty and may not meet standards required for safe and satisfactory operation. Record the model number and serial number of your equipment in the spaces provided:

Model: _____ **Date of Purchase** _____

Serial Number: (see Safety Decal section for location) _____

Provide this information to your dealer to obtain correct repair parts.

Throughout this manual, the term **IMPORTANT** is used to indicate that failure to observe can cause damage to equipment. The terms **CAUTION**, **WARNING** and **DANGER** are used in conjunction with the Safety-Alert Symbol, (a triangle with an exclamation mark), to indicate the degree of hazard for items of personal safety.



This Safety-Alert Symbol indicates a hazard and means **ATTENTION! BECOME ALERT! YOUR SAFETY IS INVOLVED!**



Indicates an imminently hazardous situation that, if not avoided, will result in death or serious injury.



WARNING

Indicates a potentially hazardous situation that, if not avoided, could result in death or serious injury, and includes hazards that are exposed when guards are removed



CAUTION

Indicates a potentially hazardous situation that, if not avoided, may result in minor or moderate injury.

IMPORTANT

Indicates that failure to observe can cause damage to equipment.

NOTE

Indicates helpful information.



TABLE OF CONTENTS

INTRODUCTION	Inside Front Cover
GENERAL INFORMATION	1
SPECIFICATIONS	2
SAFETY RULES	3
SAFETY DECALS	8
CHECK LISTS	10
OPERATOR SIGN-OFF RECORD	11
OPERATION	13
FIELD OPERATION	21
ADDITIONAL EQUIPMENT	27
SHREDDER STORAGE	28
SERVICE & MAINTENANCE	29
TROUBLE SHOOTING	41
CONTOUR FLAIL PATTERN WORKSHEETS	42
ASSEMBLY	45
INDEX TO PARTS LISTS	51
BOLT TORQUE CHART	71
ABBREVIATIONS	72
INDEX	73
REPLACEMENT PARTS WARRANTY	74
PRODUCT WARRANTY	Inside Back Cover

GENERAL INFORMATION

The purpose of this manual is to assist you in operating and maintaining your Center Drive Shredder. Read it carefully. It furnishes information and instructions that will help you achieve years of dependable performance. These instructions have been compiled from extensive field experience and engineering data. Some information may be general in nature due to unknown and varying operating conditions. However, through experience and these instructions, you should be able to develop procedures suitable to your particular situation.

The illustrations and data used in this manual were current at the time of printing, but due to possible inline production changes, your machine may vary slightly in detail. We reserve the right

to redesign and change the machines as may be necessary without notification.



WARNING

- **Some illustrations in this manual show the Center Drive Shredder with safety shields removed to provide a better view. The Center Drive Shredder should never be operated with any safety shielding removed.**

Throughout this manual, references are made to right and left direction. These are determined by standing behind the equipment facing the direction of forward travel.

SPECIFICATIONS

Maximum Outside Body Width:

12'	149 in. (3.8 m)
15'	189 in. (4.9 m)
18'	221 in. (5.6 m)
20'	253 in. (6.4 m)
22'	277 in. (7.0 m)
25'	309 in. (7.8 m)

Cutting Height..... 3 - 18 in. (7.62 cm to 45.7 cm)

Width of Cut

12'	142 in. (3.6 m)
15'	182 in. (4.6 m)
18'	214 in. (5.4 m)
20'	246 in. (6.2 m)
22'	270 in. (6.8 m)
25'	302 in. (7.6 m)

Number of Knives Cup-Knife L-Knife

12'	64	128
15'	84	168
18'	100	200
20'	116	232
22'	128	256
25'	136	272

Recommended Tire Size: 12.5 x 16 (Implement) or 12.4 x 24 (Traction)

Tire Inflation Pressure:25 psi

Rotor: Speed 1500 RPM Dynamically Balanced (L-Knife)

Rotor: Speed 1000 RPM Dynamically Balanced (Cup-Knife)

Drive: PTO..... 1000 RPM

Weight of Shredder (approximate):

12'	2800 lbs. (1270 kg)
15'	3100 lbs. (1406 kg)
18'	3400 lbs. (1542 kg)
20'	3700 lbs. (1678 kg)
22'	4000 lbs. (1814 kg)
25'	4770 lbs. (2163 kg)



SAFETY RULES

ATTENTION! BECOME ALERT! YOUR SAFETY IS INVOLVED!



Safety is a primary concern in the design and manufacture of our products. Unfortunately, our efforts to provide safe equipment can be wiped out by a single careless act of an operator.

In addition to the design and configuration of equipment, hazard control and accident prevention are dependent upon the awareness, concern, prudence and proper training of personnel involved in the operation, transport, maintenance and storage of equipment.

It has been said *"The best safety device is an informed, careful operator."* We ask you to be that kind of an operator.

The designed and tested safety of this equipment depends on it being operated within the limitations as explained in this manual.

TRAINING

- **Safety instructions are important! Read all attachment and power unit manuals; follow all safety rules and safety decal information. (Replacement manuals are available from dealer). Failure to follow instructions or safety rules can result in serious injury or death.**
- **If you do not understand any part of this manual and need assistance, see your dealer.**
- **Know your controls and how to stop engine and attachment quickly in an emergency.**
- **Operators must be instructed in and be capable of the safe operation of the equipment, its attachments and all controls. Do not allow anyone to operate this equipment without proper instructions.**
- **Keep hands and body away from pressurized lines. Use paper or cardboard, not body parts to check for leaks. Wear safety goggles. Hydraulic fluid under pressure can easily penetrate skin and will cause serious injury or death.**
- **Make sure that all operating and service personnel know that in the event hydraulic fluid penetrates skin, it must be surgically removed as soon as possible by a doctor familiar with this form of injury, or gangrene, serious injury or death will result. CONTACT A PHYSICIAN IMMEDIATELY IF FLUID ENTERS SKIN OR EYES. DO NOT DELAY**

- **Never allow children or untrained persons to operate equipment.**

PREPARATION

- **Check that all hardware is tight and properly installed. Always tighten to torque chart specifications unless instructed otherwise in this manual.**
- **Air in hydraulic systems can cause erratic operation and allow loads or equipment components to drop unexpectedly. Before operating or allowing anyone to approach the equipment, purge any air in the system by operating all hydraulic functions several times after connecting equipment, connecting hoses, or doing any hydraulic maintenance.**
- **Make sure all hydraulic hoses, fittings and valves are in good condition and not leaking before starting power unit or using equipment. Check and route hoses carefully to prevent damage. Hoses must not be twisted, bent sharply, kinked, frayed, pinched, or come into contact with any moving parts. Operate moveable components through full operational range to check clearances. Replace any damaged hoses immediately.**
- **Always wear relatively tight and belted clothing to avoid entanglement in moving parts. Wear sturdy, rough-soled work shoes and protective equipment for eyes, hair, hands, hearing, and head; and respirator or filter mask where appropriate.**
- **Ensure implement is properly attached, adjusted and in good operating condition.**
- **Make sure spring-activated locking pin or collar slides freely and is seated firmly in tractor PTO spline groove.**

(Safety Rules continued on next page)



SAFETY RULES

ATTENTION! BECOME ALERT! YOUR SAFETY IS INVOLVED!



(Safety Rules continued from previous page)

- Before starting power unit, check all equipment driveline guards for damage and make sure they rotate freely on all drivelines. Replace any damaged guards. If guards do not rotate freely on drivelines, repair and/or replace bearings before operating.
- Power unit must be equipped with ROPS or ROPS CAB and seat belt. Keep seat belt securely fastened. Falling off power unit can result in death from being run over or crushed. Keep foldable ROPS systems in "locked up" position at all times.
- Connect PTO driveline directly to power unit PTO shaft. Never use adapter sleeves or adapter shafts. Adapters can cause driveline failures due to incorrect spline or incorrect operating length and can result in personal injury or death.
- Inspect rubber flaps and swing rod before each use. Replace if damaged or missing. Flaps must pivot and hang freely so there are no gaps. Do not put equipment into service until repaired.
- Remove accumulated debris from this equipment, tractor and engine to avoid fire hazard.
- Ensure all safety decals are installed. Replace if damaged. (See Safety Decals section for location.)
- Ensure shields and guards are properly installed and in good condition. Replace if damaged.
- A minimum 20% of tractor and equipment weight must be on tractor front wheels when attachments are in transport position. Without this weight, tractor could tip over, causing personal injury or death. The weight may be attained with a loader, front wheel weights, ballast in tires or front tractor weights. When attaining the minimum 20% weight on the front wheels, you must not exceed the Roll Over Protection Structure (ROPS) weight certification. Weigh the tractor and equipment. Do not estimate.

- Make sure hydraulic hoses and cylinders are fully purged of air before operating. Keep all person away and fill the system by raising and lowering all functions several times. Air in the system can allow components to fall unexpectedly.
- Inspect and clear area of stones, branches, and other hard objects that might be thrown, causing injury or damage.

TRANSPORTING

- Power unit must be equipped with ROPS or ROPS CAB and seat belt. Keep seat belt securely fastened. Falling off power unit can result in death from being run over or crushed. Keep foldable ROPS systems in "locked up" position at all times
- Always sit in power unit seat when operating controls or starting engine. Securely fasten seatbelt, place transmission in neutral, engage brake, and ensure all other controls are disengaged before starting power unit engine.
- A minimum 20% of tractor and equipment weight must be on the tractor front wheels when attachments are in transport position. Without this weight, tractor could tip over, causing personal injury or death. The weight may be attained with a loader, front wheel weights, ballast in tires, or front tractor weights. Weigh the tractor and equipment, Do not estimate.
- Always attach safety chain to tractor drawbar when transporting unit.
- Always raise unit and install transport locks before transporting. Leak down or failure of mechanical or hydraulic system can cause equipment to drop.
- Never exceed 20 MPH during transport. See the Speed vs. Weight Ratio Table in "Field Operation, Transporting the Unit" for proper tow vehicle to machine weight ratios.
- Watch for hidden hazards on the terrain.

(Safety Rules continued on next page)



SAFETY RULES

ATTENTION! BECOME ALERT! YOUR SAFETY IS INVOLVED!



(Safety Rules continued from previous page)

- Always comply with all state and local lighting and marking requirements.
- Never allow riders on power unit or attachment.
- Do not operate PTO during transport.
- Look down and to the rear to make sure area is clear before operating in reverse.
- Do not operate or transport on steep slopes.
- Use extreme care and reduced group speed on slopes and rough terrain.
- Do not operate or transport equipment while under the influence of alcohol or drugs.

OPERATION

- Equipment may be pictured with covers open for instructional purposes. Never operate equipment with cover open.
- Do not allow bystanders in the area when operating, attaching, removing, assembling, or servicing equipment.
- Do not allow anyone to stand between tractor and unit when backing up to unit.
- Never go underneath equipment (lowered to the ground or raised) unless it is properly blocked and secured. Never place any part of the body underneath equipment or between movable parts even when the engine has been turned off. Hydraulic system leak down, hydraulic system failures, mechanical failures, or movement of control levers can cause equipment to drop or rotate unexpectedly and cause severe injury or death. Follow Operator's Manual instructions for working underneath and blocking requirements or have work done by a qualified dealer.

- Keep bystanders away from equipment
- Do not operate or transport equipment while under the influence of alcohol or drugs.
- Operate only in daylight or good artificial light.
- Avoid contact with electrical wires.
- Keep hands, feet, hair, and clothing away from equipment while engine is running. Stay clear of all moving parts.
- Always comply with all state and local lighting and marking requirements.
- Never allow riders on power unit or attachment.
- Power unit must be equipped with ROPS or ROPS CAB and seat belt. Keep seat belt securely fastened. Falling off power unit can result in death from being run over or crushed. Keep foldable ROPS systems in "locked up" position at all times.
- Always sit in power unit seat when operating controls or starting engine. Securely fasten seat belt, place transmission in neutral, engage brake, and ensure all other controls are disengaged before starting power unit engine.
- Operate tractor PTO at the RPM speed stated in "Specifications" section.
- Do not operate PTO during transport.
- Look down and to the rear and make sure area is clear before operating in reverse.
- Do not operate or transport on steep slopes.
- Do not stop, start, or change directions suddenly on slopes.
- Use extreme care and reduced ground speed on slopes and rough terrain.
- Watch for hidden hazards on the terrain during operation.

(Safety Rules continued on next page)



SAFETY RULES

ATTENTION! BECOME ALERT! YOUR SAFETY IS INVOLVED!



(Safety Rules continued from previous page)

- Stop power unit and equipment immediately upon striking and obstruction. Turn off engine, remove key, inspect, and repair any damage before resuming operation.

- Always connect safety chain from equipment to towing vehicle when transporting.

- **AVOID INJURY OR DEATH FROM POWER LINES:**

- ◆ Stay away from power lines
- ◆ Electrocutation can occur without direct contact.
- ◆ Check clearances before raising implement
- ◆ Do not leave the operator's seat if any part of the tractor or implement contacts electric lines.

- Before servicing, adjusting, repairing or unplugging, stop tractor engine, place all controls in neutral, set park brake, remove ignition key, and wait for all moving parts to stop.

- Before working underneath a raised implement, read and follow all Operator's Manual instructions and safety rules. Implement must be attached to tractor. Hydraulic system leak down, hydraulic system failures, or movement of control levers can cause equipment to drop unexpectedly and cause severe injury or death.

MAINTENANCE

- Before servicing, adjusting, repairing, or unplugging, stop tractor engine, place all controls in neutral, set park brake, remove ignition key, and wait for all moving parts to stop.

- Before working underneath a raised implement, read and follow all Operator's Manual instructions and safety rules. Implement must be attached to tractor. Hydraulic system leak down, hydraulic system failures, or movement of control levers can cause equipment to drop unexpectedly and cause severe injury or death.

- Service and maintenance work not covered in OWNER SERVICE must be done by a qualified dealership. Special skills, tools, and safety procedures may be required. Failure to follow these instructions can result in serious injury or death.

- Do not modify or alter or permit anyone else to modify or alter the equipment or any of its components in any way.

- Your dealer can supply original equipment hydraulic accessories and repair parts. Substitute parts may not meet original equipment specifications and may be dangerous.

- Always wear relatively tight and belted clothing. Wear sturdy, rough-soled work shoes and protective equipment for eyes, hair, hands, hearing and head; and respirator or filter mask where appropriate.

- Do not allow other people in the area when operating, attaching, removing, assembling or servicing equipment.

- Never go underneath equipment lowered to the ground or raised, unless it is properly blocked and secured. Never place any part of the body underneath equipment or between moveable parts even when the engine has been turned off. Hydraulic system leak down, hydraulic system failures, mechanical failures or movement of control levers can cause equipment to drop or rotate unexpectedly and cause severe injury or death. Follow Operator's Manual instructions for working underneath and blocking requirements, or have work done by a qualified dealer.

- Ensure implement is properly attached, adjusted and in good operating condition.

- Never perform service or maintenance with engine running.

- Make sure hydraulic hoses and cylinders are fully purged of air before operating. Keep all persons away and fill the system by raising and lowering all functions several times. Air in the system can allow components to fall unexpectedly.

(Safety Rules continued on next page)



SAFETY RULES

ATTENTION! BECOME ALERT! YOUR SAFETY IS INVOLVED!



(Safety Rules continued from previous page)

- **Keep all person away from operator control area while performing adjustments, service, or maintenance.**
- **Make certain all movement of implement components has stopped before approaching for service.**
- **Do not handle blades with bare hands. Careless or improper handling may result in serious injury.**
- **Tighten all bolts, nuts, and screws to torque chart specifications. Check that all cotter pins are installed securely to ensure equipment is in a safe condition before operating.**
- **Ensure all safety decals are installed. Replaced if damaged. (See Safety Decals section for location)**
- **Ensure shields and guards are properly installed and in good condition. Replace if damaged.**
- **Do not disconnect hydraulic lines until machine is securely blocked or placed in lowest position and system pressure is released by operating all valve control levers.**

STORAGE

- **Follow manual instructions for storage.**
- **Keep children and bystanders away from storage area.**



SAFETY & INSTRUCTIONAL DECALS

ATTENTION! BECOME ALERT! YOUR SAFETY IS INVOLVED!
Replace Immediately If Damaged!

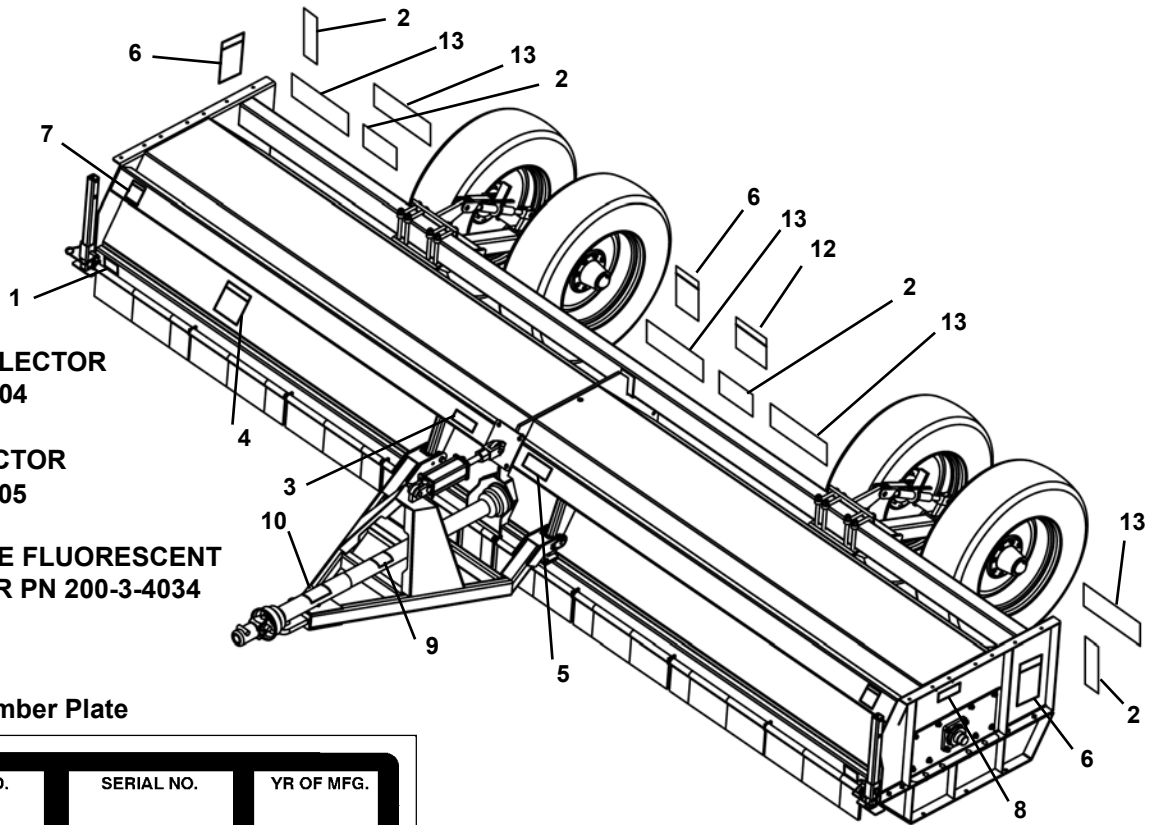

1 - AMBER REFLECTOR
PN 200-3-4004

2 - RED REFLECTOR
PN 200-3-4005

13 - RED-ORANGE FLUORESCENT REFLECTOR
PN 200-3-4034

3 - Serial Number Plate

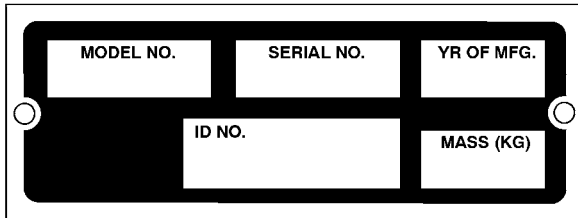

5 - PN 500-3-0978



6 - PN 500-3-0982

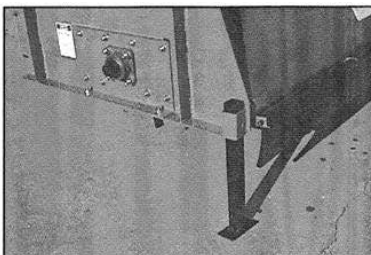

4 - PN 500-3-0977



(Safety Decals continued on next page)



SAFETY & INSTRUCTIONAL DECALS
ATTENTION! BECOME ALERT! YOUR SAFETY IS INVOLVED!
 Replace Immediately If Damaged!



⚠ DANGER



**GUARD MISSING.
DO NOT OPERATE.**

⚠ DANGER



**GUARD MISSING.
DO NOT OPERATE.**

33347E

⚠ DANGER

9 - PN 33347

⚠ WARNING

MANUAL CONTAINER AND MANUAL ARE MISSING

- REPLACE AND READ BEFORE OPERATING.
- KEEP MANUAL CONTAINER AND MANUAL MOUNTED IN THIS LOCATION. (Available from dealer or call 1-877-275-8714.)

FAILURE TO FOLLOW MANUAL INSTRUCTIONS AND SAFETY RULES CAN RESULT IN SERIOUS INJURY OR DEATH. 506-3-0192

8 - PN 50630192

10 - PN 18864

⚠ DANGER



**ROTATING DRIVELINE
CONTACT CAN CAUSE DEATH
KEEP AWAY!**

DO NOT OPERATE WITHOUT-

- ALL DRIVELINE GUARDS, TRACTOR AND EQUIPMENT SHIELDS IN PLACE
- DRIVELINES SECURELY ATTACHED AT BOTH ENDS
- DRIVELINE GUARDS THAT TURN FREELY ON DRIVELINE

18864B

⚠ WARNING



THROWN OBJECT HAZARD

To prevent serious injury or death:

1. Stay away from the front of machine when operating.
2. Keep others away.
3. Keep deflectors in good condition when operating.

505-3-0314

7 - PN 50530314

⚠ WARNING



HIGH-PRESSURE FLUID HAZARD

To prevent serious injury or death:

1. Relieve pressure on system before repairing, adjusting or disconnecting.
2. Wear proper hand and eye protection when searching for leaks. Use wood or cardboard instead of hands.
3. Keep all components in good repair.

505-3-0315

12 - PN 50530315

CHECK LISTS

PRE-DELIVERY CHECK LIST

(DEALER'S RESPONSIBILITY)

Inspect the equipment thoroughly after assembly to ensure it is set up properly before delivering it to the customer.

The following check lists are a reminder of points to inspect. Check off each item as it is found satisfactory or after proper adjustment is made.

- Check that all safety decals are installed and in good condition. Replace if damaged.
- Check that shields and guards are properly installed and in good condition. Replace if damaged.
- Check that PTO shaft is properly installed.
- Properly attach implement to tractor and make all necessary adjustments.
- Check all bolts to be sure they are tight.
- Check wheel bolts for proper torque.
- Check that all cotter pins and safety pins are properly installed. Replace if damaged.
- Check and grease all lubrication points as identified in "Service, lubrication information."
- Check the level of gearbox fluids before delivery. Service, if required, as specified in the "Service, lubrication information."
- Check that tractor hydraulic reservoir has been serviced and that hydraulic system and all functions have been operated through full cylinder stroke to purge air from system.
- After pressurizing and operating all Shredder functions, stop tractor and make sure there are no leaks in the hydraulic system. Follow all safety rules when checking for leaks.

DELIVERY CHECK LIST

(DEALER'S RESPONSIBILITY)

- Check all bolts to be sure they are tight.
- Show customer how to make adjustments and select proper PTO speed.
- Show customer how to make adjustments.
- Instruct customer how to lubricate and explain importance of lubrication.
- Point out the safety decals. Explain their meaning and the need to keep them in place and in good condition. Emphasize the increased safety hazards when instructions are not followed.
- Present Operator's Manual and request that customer and all operators read it before operating equipment. Point out the manual safety rules, explain their meanings and emphasize the increased safety hazards that exist when safety rules are not followed.
- Show customer how to make sure driveline is properly installed and that spring-activated locking pin or collar slides freely and is seated in groove on tractor PTO shaft.
- Show customer the safe, proper procedures to be used when mounting, dismounting, and storing equipment.
- Explain to customer that when equipment is transported on a road or highway, safety devices should be used to give adequate warning to operators of other vehicles.
- Explain to customer that when equipment is transported on a road or highway, a Slow Moving Vehicle (SMV) sign should be used to provide adequate warning to operators of other vehicles.
- Explain to customer that when towing on a public road to comply with all state and local lighting & marking laws and to use a safety tow chain.
- Make customer aware of optional equipment available so that customer can make proper choices as required.
- Point out all guards and shields. Explain their importance and the safety hazards that exist when not kept in place and in good condition.

OPERATOR SIGN-OFF RECORD

Safety is a primary concern in the design and manufacture of our products. Unfortunately, our efforts to provide safe equipment can be wiped out by an operator's single careless act.

In addition to the design and configuration of equipment, hazard control and accident prevention are dependent upon the awareness, concern, judgement, and proper training of personnel involved in the operation, transport, maintenance and storage of equipment.

It has been said "The best safety device is an informed, careful operator." We ask you to be that kind of operator.

American Society of Agricultural & Biological Engineers (ASAE) and the Occupational Safety and Health Administration (OSHA).

Anyone who will be operating and/or maintaining the Seedbetter must read and clearly understand all Safety, Operating, and Service & Maintenance information presented in this manual.

Do not operate or allow anyone else to operate this equipment until this information has been reviewed. Review this information annually, before the season start-up. Make periodic reviews of the Safety and Operation sections a standard practice for those using any of your equipment.

Use the following Operator Sign-off Record to verify that each operator has read and understood the information in this manual and has been instructed in the safe operation of the Seedbetter.

DATE	OPERATOR'S NAME	OPERATOR'S SIGNATURE

OPERATION

Safety is a primary concern in the design and manufacture of our products. Unfortunately, our efforts to provide safe equipment can be wiped out by an operator's single careless act.

In addition to the design and configuration of equipment, hazard control and accident prevention are dependent upon the awareness, concern, judgment, and proper training of personnel involved in the operation, transport, maintenance and storage of equipment.

It has been said "The best safety device is an informed, careful operator." We ask you to be that kind of operator.

- The Alloway Flail Shredder is designed to pick up and shred crop and plant residue left in the field. Rotational power to the flails is provided by the tractor PTO.
- Be familiar with the flail shredder before starting.
- The owner is responsible for training operators in the safe operation of the flail shredder.



WARNING

- **Safety instructions are important! Read all attachment and power unit manuals; follow all safety rules and safety decal information. (Replacement manuals are available from your Alloway dealer.) Failure to follow instructions or safety rules can result in serious injury or death.**
- **Never allow children or untrained persons to operate equipment.**
- **Make sure shields and guards are properly installed and in good condition. Replace if damaged.**
- **Keep hands, feet, hair, and clothing away from equipment while engine is running. Stay clear of all moving parts.**
- **Before dismounting power unit or performing any service or maintenance, follow these steps: disengage power to equipment, lower the 3-point hitch and all raised components to the ground, operate valve levers to release any hydraulic pressure, set parking brake, stop engine, remove key, and unfasten seat belt.**
- **Never allow riders on power unit or attachment.**
- **Do not allow bystanders in the area when operating, attaching, removing, assembling, or servicing equipment.**
- **Keep hands, feet, hair, and clothing away from equipment while engine is running. Stay clear of all moving parts.**



CAUTION

- **Always sit in power unit seat when operating controls or starting engine. Securely fasten seat belt, place transmission in neutral, engage brake, and ensure all other controls are disengaged before starting power unit engine.**
- **Never allow riders on power unit or attachment.**
- **Keep bystanders away from equipment.**
- **Operate tractor PTO at the RPM speed stated in "Specifications" section.**
- **Always comply with all state and local lighting and marking requirements.**
- **Always wear relatively tight and belted clothing to avoid entanglement in moving parts. Wear sturdy, rough-soled work shoes and protective equipment for eyes, hair, hands, hearing, and head; and respirator or filter mask where appropriate.**

Operation Continued

PRINCIPAL COMPONENTS

The Alloway Flail Shredder consists of a large rotating drum with free-swinging steel flails attached. The flails pick up or strike crop residue or trash and shred it. Rotational power to the drum is provided by the tractor PTO through a gearbox in the center of the machine.

For removing the center strip of crop residue, an optional hydraulically driven blade can be installed under the cover in the center of the machine. The flail shredder is designed to be used as a pull-type, semi-mounted, or 3-point mounted machine.

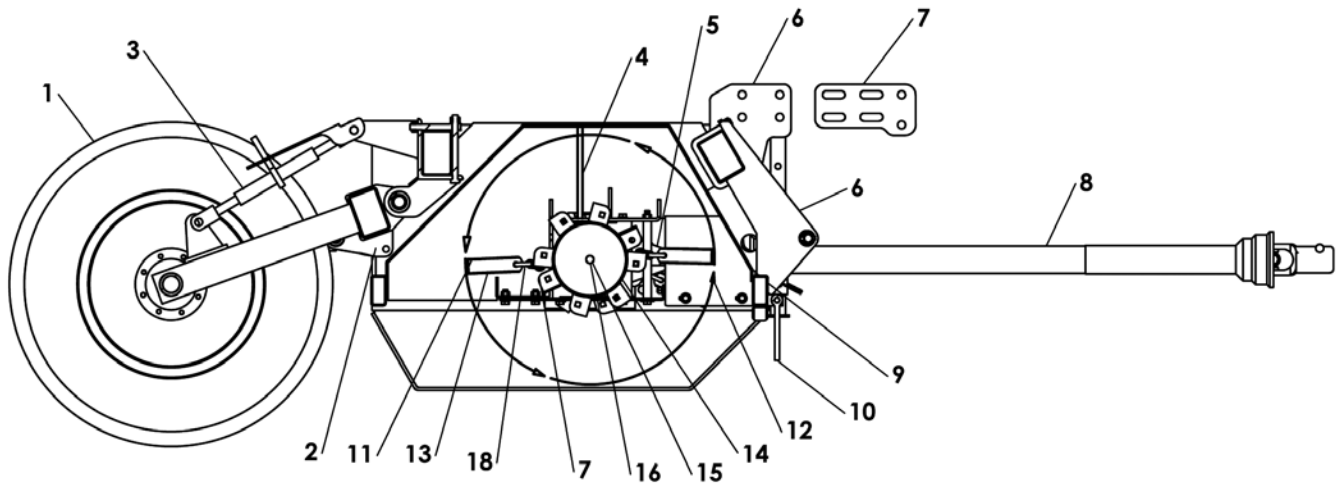

Figure 1a. Flail Shredder with 3-Pt Hitch Principal Components

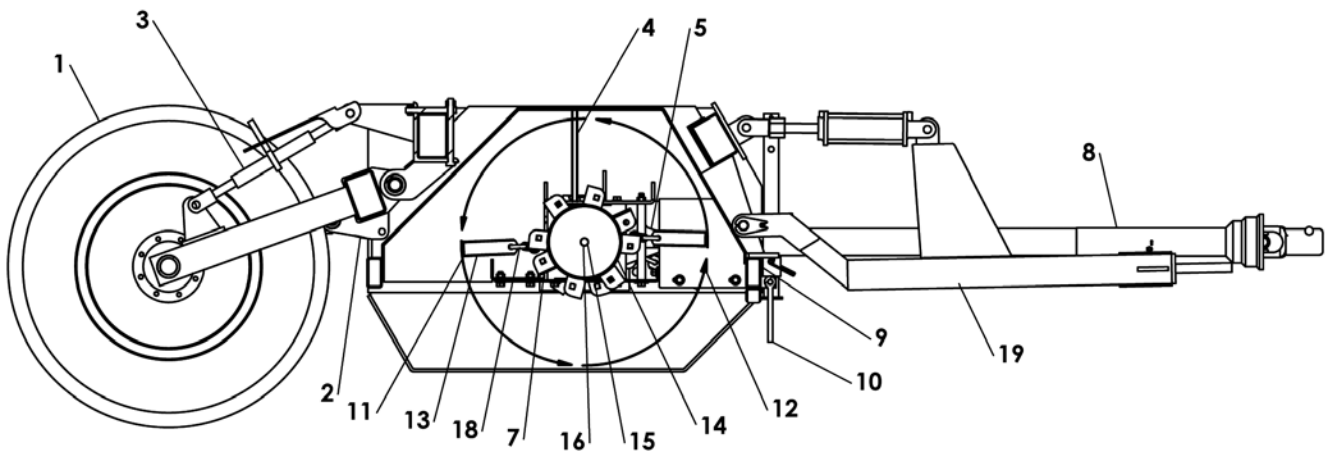

Figure 1b. Pull Type Flail Shredder Principal Components

- | | | | |
|-------------------------------|-------------------------|---------------------|----------------|
| 1. Wheels | 2. Rear Hitch | 3. Ratchet | 4. Dipstick |
| 5. Gearbox | 6. 3-Point Hitch | 7. Floating Mast | 8. Driveline |
| 9. Frame | 10. Rubber Shield Flaps | 11. Flails | 12. Tip Speed |
| 13. "Cup" or "L" Knife Flails | 14. Rotor (Flail Tube) | 15. End Bearing | 16. Stub Shaft |
| 17. Flail Tube Clip | 18. D-Ring | 19. Pull-Type Hitch | |

Operation Continued

PRE-OPERATION CHECK LIST

(OWNER'S RESPONSIBILITY)

IMPORTANT

■ **This Pre-Operation Check List is provided for the operator. It is important to follow for both personal safety and maintenance of the flail shredder.**

— Check all bolts to be sure they are tight.

— Check all lubrication points and grease as instructed in Lubrication Schedule, page 33.

— Use only a tractor of adequate power and weight to pull the unit.

— Check that the unit is properly attached to the tractor. On pull-type unit, be sure there is a mechanical retainer through the drawbar pin and the safety chain is installed. On 3-point hitch units, be sure retainers are used on the mounting pins.

— Check oil level in gearbox. Add oil as required.

— Check that the PTO driveline turns freely and that the driveline can telescope easily.

— Check tire pressure. Bring to specified level.

— Check flails. Inspect for damage or breakage. Make sure the swing freely on their mount. Repair or replace as required.

— Check condition of cutter blade (if so equipped).

— Inspect all hydraulic lines, hoses, couplers, and fittings. Tighten, repair, or replace any leaking or damaged components.

— Install and secure all guards, doors, and covers.

— Check PTO clutch operation (See Servicing Weasler Modular Friction Clutch, page 44).

CHOOSING THE CORRECT EQUIPMENT

To ensure safe and reliable operation of the flail shredder, use a tractor with the correct specifications. Use the following guidelines to select the correct tractor.

1. Horsepower

Use Table 1 for selecting the tractor horsepower class appropriate for your unit's width.

Increase the horsepower level by 25 percent when operating in hilly, soft, or wet conditions.

2. Tractor Weight

By following recommendations for tractor horsepower, the tractor will have sufficient weight to provide stability for unit during field operation or when transporting.

When using a 3-point mounted shredder, It is recommended that each tractor be equipped with a full complement of suitcase weights on the tractor front (see Figure 2 for example). This will provide the required front weight for turning and extra traction if equipped with front wheel assist.

Width	Minimum Horsepower
12'	60
15'	75
18'	90
20'	100
22'	110
25'	120

Table 1: Tractor Horsepower vs. Unit Width



Figure 2. Front Suitcase Weights

Operation Continued

3. Point Hitch

The 3-point hitch models require the tractor to be equipped with a Category II or Category III 3-point hitch. If the hitch can be converted from one to the other, use a Category III to provide a wider stance and more stability.

Use the upper pin hole for Category III and the lower hole for Category II as shown in Figure 3.

For easier attachment, use a quick hitch. If not using a quick hitch, use optional hitch extension.

4. Load Sensing Hydraulics (3-Point models only)

Many newer tractors are equipped with “load sensing” hydraulics. The operator is responsible for setting the tractor hydraulic system to provide “float” on the 3-point hitch. Refer to the tractor manual for specific instructions.

The “float” feature will allow the unit to follow the ground contours during operation. This applies to 3-point mounted machines only.

5. Drawbar (Pull-type models only)

The tractor drawbar must be set to provide 16” - 20” (406 mm - 508 mm) between the end of the PTO shaft and the center of the drawbar pin for all and 1000 rpm PTO. See Figure 4. This dimension will provide the required clearance for the CV (Constant Velocity) joint on the front of the driveline.

IMPORTANT

- **Do not use PTO shaft adapters. They will change the drawbar dimension and can cause driveline failures.**

NOTE: On pull-type models, do not cut driveline.

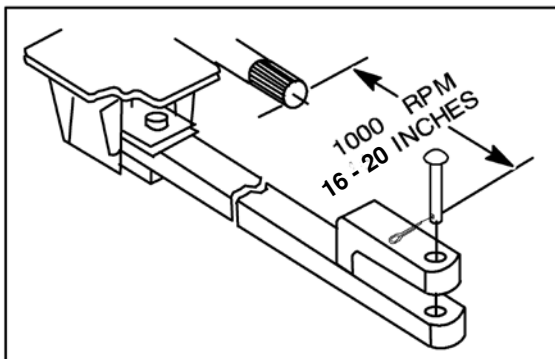

Figure 4. Drawbar Dimensions



Figure 3. 3-Point Hitch Attachment

BREAK-IN OF THE FLAIL SHREDDER

The following should be observed when operating the unit for the first time:

IMPORTANT

- **Before operating the unit in the field, run the PTO clutch. See Servicing Weasler Modular Friction Clutch, page 44.**

After operating for 1/2 hour

1. Check all nuts, bolts, and other fasteners. Tighten to specifications given in the Bolt Torque Chart, page 72.
2. Tighten wheel bolts to specifications given in the Bolt Torque Chart, page 72.
3. Check that the flails are in good condition and swing freely.
4. Check oil level in the gearbox. Add oil if needed.
5. Check that the PTO driveline shield turns freely.
6. Lubricate all grease points.

After operating for 5 to 10 hours

1. Repeat Steps 1 to 5 above.
2. Follow regular service schedule as outlined in Service & Maintenance.

Operation Continued

PTO Driveline Length

(3-Point & 2-Point models only)

The unit is equipped with a PTO driveline long enough to fit any tractor and 3-point linkage system.

The operator is responsible for measuring the dimensions of the driveline through its working range. These dimensions will indicate if the drive-line requires shorting to operate on the particular tractor/unit attachment system. The operator must check dimensions before using the unit for the first time and each time a different tractor is used with the unit

Use the following procedure when determining driveline dimension:

1. Clear the area of bystanders, especially children.



WARNING

- **Keep bystanders away from equipment.**

2. Attach the 3-point hitch to the unit but not the PTO driveline.
3. Raise the unit until the tractor PTO and gearbox shafts are the same height.
4. Measure the dimension between the shaft grooves on the tractor and implement ends. If this dimension is less than 34.81 inches, the shaft will require shortening.

5. Move the unit to its highest and lowest working position and measure this dimension again. The unit's shaft can telescope (see Figure 6) before it has been shortened.
6. If required, shorten the shaft to prevent bottoming out during use. NOTE: An extra inch of compression space in the shaft can eliminate bottoming out during use. Measure to make sure.
7. Use an abrasive wheel power saw to cut the male end of the shaft. Cut the same amount from both the splined shaft and the safety shield. See Figure 5. Use a file to remove any burrs from the cut end.

IMPORTANT

- **Cut only the male end. Never cut the female end.**
8. Never cut more than 9 inches from the male end. Cutting 1 inch from the male end shortens both the minimum and maximum lengths by 1 inch.

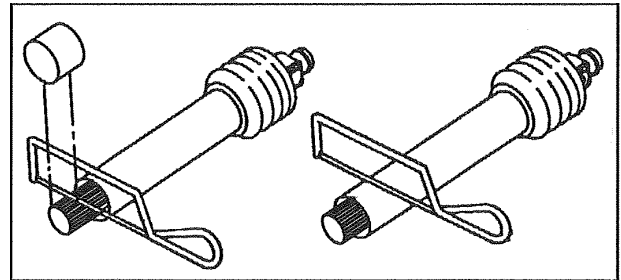

Figure 5. Cutting the Driveline Shaft

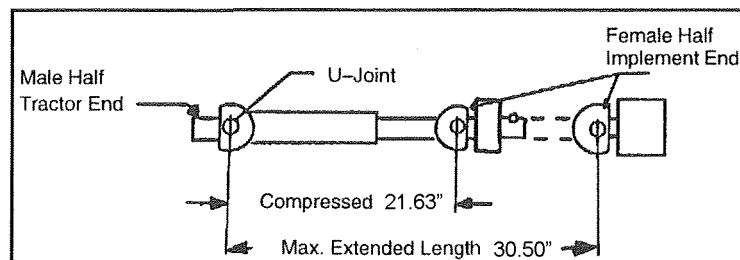

Figure 6. Driveline Dimension - 3-Pt Hitch

Operation *Continued*

ATTACHING THE SHREDDER TO THE TRACTOR

1. Place unit on a level, dry area free of debris and other foreign object.



WARNING

- **Keep bystanders away from equipment.**
2. Clear the area of bystanders, especially children.
 3. Provide enough clearance to back the tractor safely into the unit.



CAUTION

- **Do not allow anyone to stand between tractor and unit when backing up to the unit.**

3-point and 2-point models:

4. Set the height of the 3-point hitch so that quick hitch claws are lower than the mounting pins.
5. Make sure 3-point hitch is set in the non-sway position. See tractor manual for details.
6. Align the claws under the mounting pins (see Figure 7) while backing up.

NOTE: For a Category II hitch, use the bottom hole for the center pin. For a Category III hitch, use the top hole for the center pin.

7. When the claws are under the pins, slowly raise the 3-point hitch. Make sure each mounting pin seats in its respective claw.
8. Release the claw retainer locks to secure the mounting pins in the claws.
9. Check the top link frame. It should be free to slide in its mounting slots. This movement allows the unit to follow the ground contour when cresting a hill or going through a depression.



Figure 7. Attaching to 3-point model

Pull-type model:

4. Use the ratchet (see Figure 8) on top of the niche to set the hitch height.
5. Check and set the drawbar dimension.
6. Back the tractor up to the hitch.
7. Use a hardened drawbar pin that provides for a mechanical retainer, such as a Klik pin.
8. Attach a safety chain around the drawbar or cage to prevent unexpected separation. Provide sufficient slack for turning.
9. Use the ratchet to transfer the unit's weight to the drawbar.
10. Make sure the drawbar is pinned in its center position.



Figure 8. Attaching to Pull-type model

Operation *Continued*

Attach PTO Driveline:

11. Check and set the drawbar dimension.

IMPORTANT

- **The drawbar may need repositioning to provide clearance for the driveline.**
12. Attach the driveline to the tractor by retracting the locking collar. Slide the yoke over the shaft and push on the yoke until the lock collar clicks into position. Make sure the yoke is locked into position. See Figure 9.

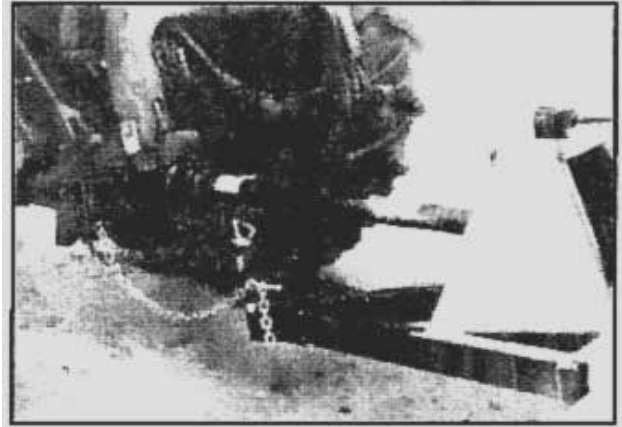

Figure 9. Hitch PTO Components

Attach Hydraulics:

13. Use a clean cloth to clean hose ends and area around the couplers on the tractor.
14. Insert the hose male ends into the tractor couplers. Make sure hoses lock in place.
15. Route hoses along or over the hitch and secure in position with clips, tape, or plastic ties. Provide enough slack for turning and lifting.

Raise Stands:

16. Use hitch ratchets or 3-point hitch to raise the front of the machine.
17. Unpin front frame stands. Raise and pin in their upper position. See Figure 10.



Figure 10. Parking Stand

REMOVING THE SHREDDER FROM THE TRACTOR

1. Reverse the above procedure (Steps 1-17) when removing unit from the tractor.

FIELD OPERATION

The Alloway Flail Shredder is designed with the flexibility to operate well in almost any kind of crop and terrain conditions. However, the operator is responsible for being familiar with all operating and safety procedures and following them.

Each operator should review this Field Operation section at the start of the season and as often as required to be familiar with the unit.

Operators should also review the PRE-OPERATION CHECK LIST, Attaching the Shredder to the Tractor, and Transporting the Unit.



WARNING

- **Safety instructions are important! Read all attachment and power unit manuals; follow all safety rules and safety decal information. (Replacement manuals are available from your Alloway dealer.) Failure to follow instructions or safety rules can result in serious injury or death.**
- **Never allow children or untrained persons to operate equipment.**
- **Make sure shields and guards are properly installed and in good condition. Replace if damaged.**
- **Keep hands, feet, hair, and clothing away from equipment while engine is running. Stay clear of all moving parts.**
- **Before dismounting power unit or performing any service or maintenance, follow these steps: disengage power to equipment, lower the 3-point hitch and all raised components to the ground, operate valve levers to release any hydraulic pressure, set parking brake, stop engine, remove key, and unfasten seat belt.**



WARNING

- **Never allow riders on power unit or attachment.**
- **Do not allow bystanders in the area when operating, attaching, removing, assembling, or servicing equipment.**
- **Inspect and clear area of stones, branches, or other hard objects that might be thrown, causing injury or damage.**
- **Operators must be instructed in and be capable of the safe operation of the equipment, its attachments, and all controls. Do not allow anyone to operate this equipment without proper instructions.**



CAUTION

- **Never allow children or untrained persons to operate equipment.**
- **Always sit in power unit seat when operating controls or starting engine. Securely fasten seat belt, place transmission in neutral, engage brake, and ensure all other controls are disengaged before starting power unit engine.**
- **Keep bystanders away from equipment.**
- **Operate tractor PTO at the RPM speed stated in “Specifications” section.**
- **Always comply with all state and local lighting and marking requirements.**
- **Always wear relatively tight and belted clothing to avoid entanglement in moving parts. Wear sturdy, rough-soled work shoes and protective equipment for eyes, hair, hands, hearing, and head; and respirator or filter mask where appropriate.**

Field Operation *Continued*

TRANSPORTING THE UNIT



WARNING

- Never allow riders on power unit or attachment.



CAUTION

- Always comply with all state and local lighting and marking requirements.

1. Be sure all bystanders are clear of the unit.
2. Be sure center cutter is disengaged and has stopped turning (if so equipped).
3. Be sure the unit is securely attached to the tractor and all retainer pins are installed.
4. Be sure safety chain is installed on pull-type model.
5. Raise the machine.
6. Clean the SMV emblem, lights, and reflectors and be sure they are working.
7. Be sure you are in compliance with all applicable lighting and marking regulations when transporting. Check with your local authorities.
8. Never transport the unit faster than 20 mph (32 kmph). The ratio of the tractor weight to the shredder weight plays an important role in defining acceptable travel speed. Table 2 summarizes the recommended travel speed-to-weight ratio.

Road Speed	Fully equipped or loaded implement(s) weight relative to towing machine weight
Up to 32 km/h (20 mph)	1 to 1 or less
Up to 16km/h (10 mph)	2 to 1 or less
Do not tow	more than 2 to 1

Table 2: Speed vs. Weight Ratio

PREPARING FOR OPERATION

1. Pull into the field and position the unit in a level area.
2. Lower into operating position.
3. 3-Point hitch models: Set the 3-point so the quick hitch is vertical and the floating upper mast is forward.

Flail Height:

4. Set the unit to give a flail height of **at least 2-1/2 to 6 inches (75 to 150 mm)** above the ground. This will minimize the amount of stones and dirt picked up by the flails under all operating conditions.

NOTE: To avoid unnecessary wear on knives and related parts, never set the unit lower than the recommended setting.



Figure 15. Flail Height

Field Operation *Continued*

SET OPERATING HEIGHT

3-Point hitch models:

Use the ratchet on the cylinder stops on the rear struts and on third link of 3-point to set the unit height.



Figure 16. 3-Point Hitch Models

Pull-type models:

Use the cylinders on the hitch and rear struts to set the unit height.



Figure 17. Pull-type Models

3-Point & 2-Point Hitch Models:

1. Set lower 3-point arms in the free-float position.
2. Set the hitch in the non-swing position.
3. Set the hydraulic system to allow the 3-point to float. Refer to tractor manual for instructions.
4. **3-Point models only:** Be sure the floating mast is free to slide in its mounting frame to allow the machine to follow ground contours. Refer to Figure 18.

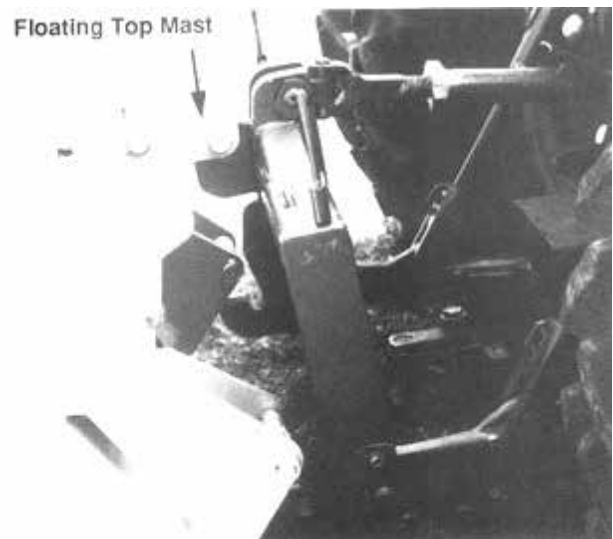

Figure 18. Free-float position

Field Operation *Continued*

FLAIL TYPES

The shredder is factory equipped with “L” or cup type flails. The two types are interchangeable.

“L” Flails, “L” Flails w/ D-Ring

“L” flails (Figure 20) work best when trash or crop residue is standing.

Cup Flails

Cup flails (Figure 21) can pick up material from the ground and work best in matted trash conditions.

The standard cup flail is 11 inches (279 mm) long and is used for most applications. Optional 7 and 9 inch (177 and 228 mm) flails are available to match the tip position to ground contour.

Attach optional cup flails as follows (see Figure 19):

1. Leave standard flails located between the rows.
2. Remove others and install shorter flails to follow ground contour. Be sure to mount the same size flails on opposite sides of the tube. Measure the row spacing and flail position carefully to minimize ground contact.



Figure 20. “L” Flails

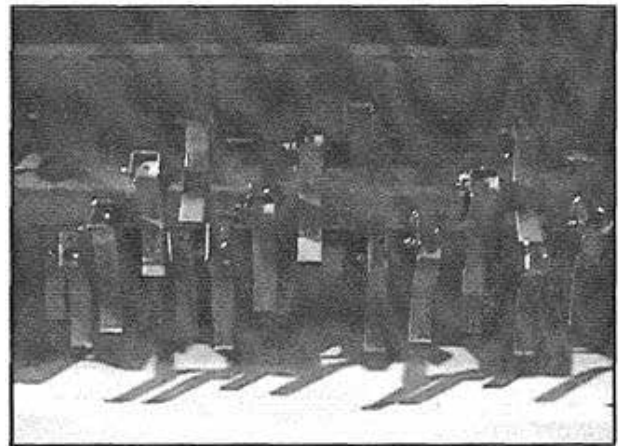

Figure 21. Cup Flails

SETTING FLAIL HEIGHT

1. Be sure wheels are set to follow in the center of furrow row. **Set flails 3 to 6 inches (75 to 150 mm) above the ground.**
2. Align the unit with the working area on or between rows on flat farming.
3. **3-Point models:** Set the 3-point hitch so the wheels carry only a small portion of the unit's weight and act more as stabilizing wheels. See tractor manual for setting hitch.

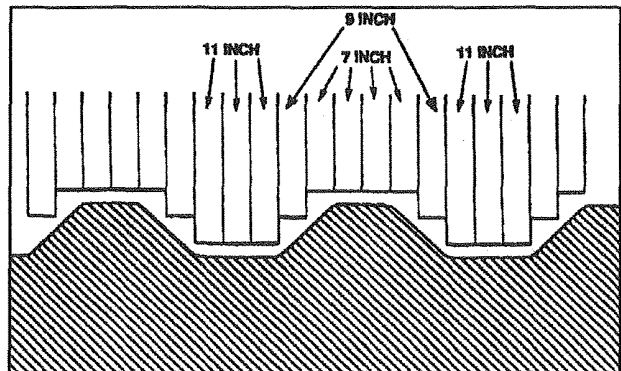

Figure 19. Optional Flail Contour

Field Operation *Continued*

SETTING OUTER TRAILING WHEELS

Normally, wheels are set to track in the row centers, between the raised seed beds. Tire position will determine flail height, but depth of furrow is also a factor in setting flail height. In some conditions the furrow between the seed beds is deeper on the ends, where irrigation waters enter the field. As furrows change depth, flail height will change.

To compensate for the depth change, move the trailing wheels against the side of the outer seed bed (see Figure 22). The wheels will then tend to climb up the side of the seed bed and prevent the flails from hitting the top of the bed.

Set the flail height after the wheels have been moved against the seed bed.

Adjust wheel position by moving spindle to different hole location in spindle holder tube.

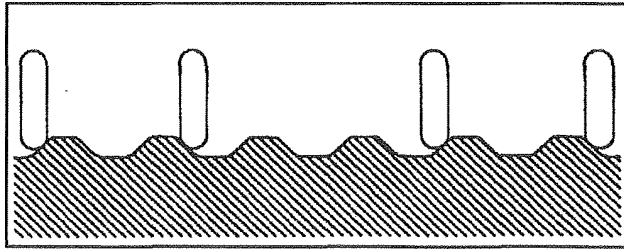

Figure 22. Wheel Position

STARTING THE TRACTOR

1. Run tractor engine at low idle.
2. Slowly engage PTO control to start the shredder.
3. Slowly bring tractor engine to rated PTO speed. Never exceed rated speed.

STOPPING THE TRACTOR



WARNING

- **Before dismounting power unit or performing any service or maintenance, follow these steps: disengage power to equipment, lower the 3-point hitch and all raised components to the ground, operate valve levers to release any hydraulic pressure, set parking brake, stop engine, remove key, and unfasten seat belt.**
1. Slowly decrease engine speed to low idle.
 2. Slowly disengage PTO clutch. The overrunning clutch will allow the shredder to freewheel down.
 3. Restart the unit only after the drums quit turning. The PTO will not need to be disengaged to lift the unit on the ends or while turning.

Field Operation *Continued*

HAZARD AREA



WARNING

- **Make certain all movement of equipment components has stopped before approaching for service.**

Stay away from front, side, and rear of unit while it is running. Flails can pick up stones, sticks, wire, and other debris and throw it out with enough force to severely injure bystanders.

Keep out of shaded area shown in Figure 24.

Shut down unit and wait for moving parts to stop before approaching.

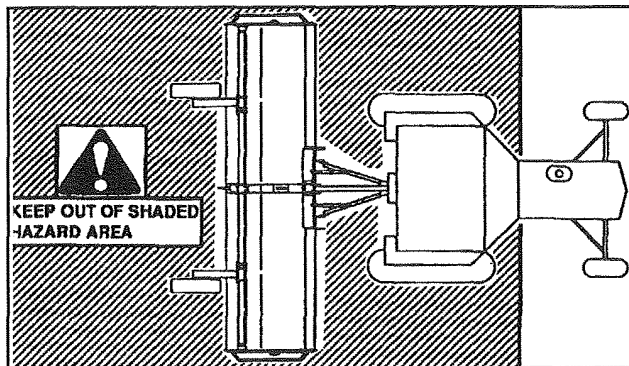

Figure 24. Hazard Area

GROUND SPEED

Travel speed can vary between 3 and 8 mph (5 and 13 kmph) depending on the bulk of residue and terrain conditions. The operator is responsible for noting the condition of the work, setting the speed to obtain a quality shredding job, and maintaining control of the unit.

Speed may be increased if shredding quality is good.

Decrease speed if trash is left standing or if some is not picked up.

TURNING

3-Point mounted units:

Always raise the unit slightly to lift rear wheels off the ground before turning. This will eliminate side loads on the wheel assembly, unless unit is equipped with castor wheels.

Pull-type units:

The front universal is equipped with a CV (Constant Velocity) joint to allow for turning. Although the CV joint allows for sharper turns than a regular drive-line, it does have some limitations. Refer to Figure 25.

CV joint angle should not exceed 80 degrees in either operating or standstill condition of the drive-line. Larger angles will damage the joint.

The angle should never exceed 35 degrees when the driveline is under full load.

IMPORTANT

- **Disengage PTO when making sharp turns.**

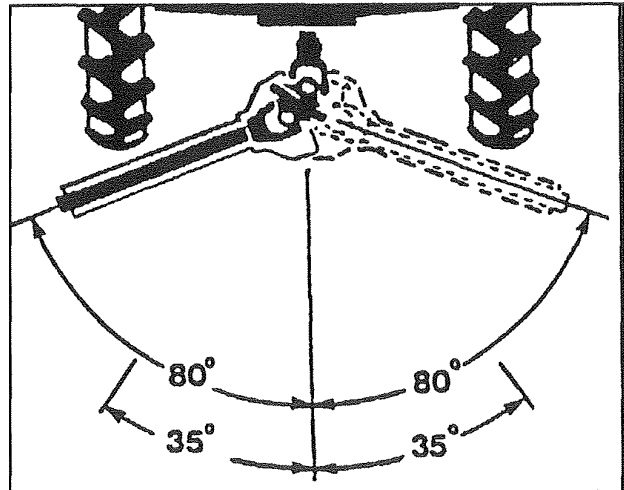

Figure 25. CV Joint Angles

ADDITIONAL EQUIPMENT

Center Divider *(Optional)*

An optional center divider (Figure 27) can be mounted under the gearbox for pushing trash to the flails.



Figure 27. Optional Center Divider

Front Shield Flap

All units are equipped front shield flaps (Figure 28) along the front of the frame. The shield flaps stop or deflect any trash, stones, or other debris picked up by the flails.

Be sure the shield flaps are in good condition for operation. Replace if damaged, torn, or missing.



Figure 28. Front Shield Flap

End Guards & Skids

All units are equipped with end guard skids (Figure 29) to prevent flying debris or flail-to-ground contact.



WARNING

- Replace damaged or missing skids immediately.



Figure 29. Skids

STORAGE



WARNING

- **Block equipment securely for storage.**
- **Keep children and bystanders away from storage area.**

At the end of the season, the shredder should be thoroughly inspected and prepared for storage. Repair or replace any worn or damage components to prevent unnecessary down time at the beginning of the next season.

To ensure a long, trouble-free life, prepare the unit for storage by carrying out the following procedure:

1. Clear the area of bystanders, especially children.
2. Thoroughly wash the unit, using a pressure washer to remove all dirt, mud, debris, and residue.
3. Inspect the flails and rotors for damage or entangled material. Remove entangled material. Repair or replace damaged parts.
4. Inspect all hydraulic hoses, lines, couplers, and fittings. Tighten all loose fittings. Replace any hose that is cut, nicked, abraded, or separating from the crimped end of a fitting.
5. Change gearbox oil.
6. Lubricate all grease fittings. Make sure all grease cavities have been filled with grease to remove any water residue from from pressure washing.
7. Touch up all paint nicks and scratches to prevent rust.
8. Move to storage area. Select a dry area free of debris. Store in an area away from human activity.
9. Unhook from tractor (see Removing the Shredder from the Tractor, page 18).
10. Place safety stands or large blocks under the frame to take the load off the tires.

NOTE: Do not deflate tires.

11. If the unit cannot be placed indoors, cover with a waterproof tarpaulin and tie securely. Store away from human activity
12. Do not allow children to play on or around the stored unit.

SERVICE & MAINTENANCE



WARNING

- Before dismantling power unit or performing any service or maintenance, follow these steps: disengage power to equipment, lower the 3-point hitch and all raised components to the ground, operate valve levers to release any hydraulic pressure, set parking brake, stop engine, remove key, and unfasten seat belt.
- Before working underneath, read manual instructions, securely block up, and check stability. Secure blocking prevents equipment from dropping due to hydraulic leak down, hydraulic system failure, or mechanical component failure.
- Keep all persons away from operator control area while performing adjustments, service, or maintenance.

- Make sure shields and guards are properly installed and in good condition. Replace if damaged.

- Do not handle blades with bare hands. Careless or improper handling may result in serious injury.



CAUTION

- Always wear relatively tight and belted clothing to avoid entanglement in moving parts. Wear sturdy, rough-soled work shoes and protective equipment for eyes, hair, hands, hearing, and head; and respirator or filter mask where appropriate.
- Make certain all movement of equipment components has stopped before approaching for service.

LUBRICANTS

Use the Lubrication Service Record (Page 36), to keep a record of all scheduled maintenance.

1. Grease

Use and SAE multi-purpose high temperature grease with extreme pressure (EP) performance. A SAE multi-purpose lithium-based grease is also acceptable.

2. Gearbox Oil

Use an SAE 85W90 gear oil for all operating conditions. Capacity: 2-1/2 U.S. quarts (2.13 liters)

3. Storing Lubricants

Your unit can operate at top efficiency only if clean lubricants are used. Use clean containers to handle all lubricants. Store them in an area protected from dust, moisture, and other contaminants.

GREASING

Use the Lubrication Service Record (Page 36), to keep a record of all scheduled maintenance.

1. Use a hand-held grease gun for all greasing.
2. Wipe grease fitting with a clean cloth before greasing to avoid injecting dirt and grit.
3. Replace and repair broken fittings immediately.
4. If fittings will not take grease, remove and clean thoroughly. Also clean lubricant passageway. Replace fitting if necessary.

Service & Maintenance *Continued*

LUBRICATION SCHEDULE

NOTE: Recommendations are based on normal operating conditions. Severe or unusual conditions may require more frequent lubrication or oil changes. Refer to Figure 30.

Daily or every 8 hrs of operation:

PTO Driveline: Lubricate daily or every 8 hours of operation (every 4 hours if U-joints run at angles). See Figure 29 for lubrication points.

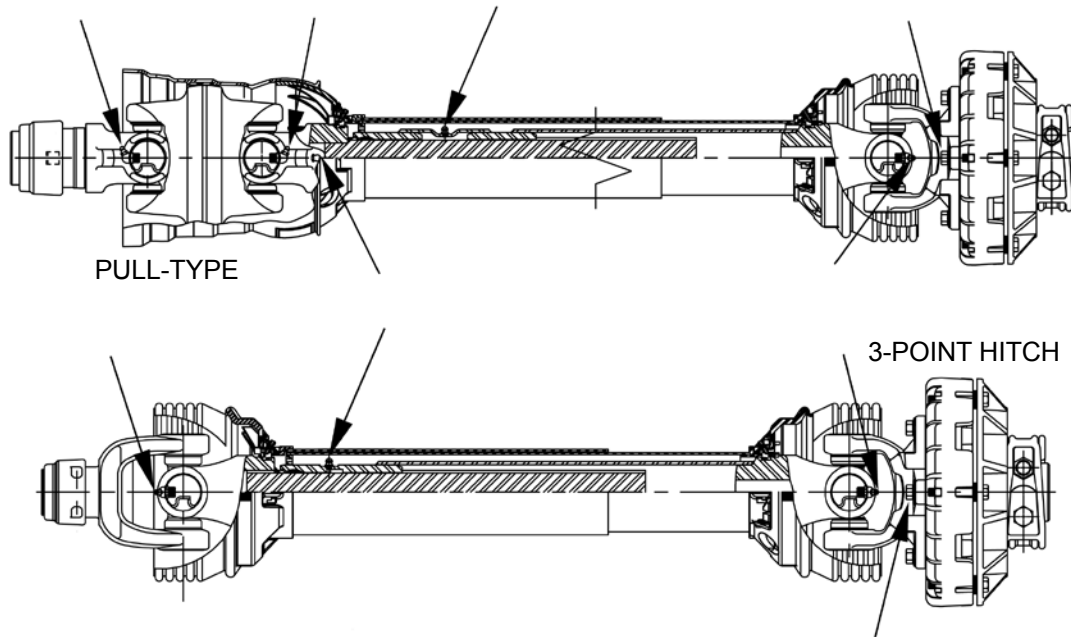

Figure 29. PTO Driveline Lubrication Points

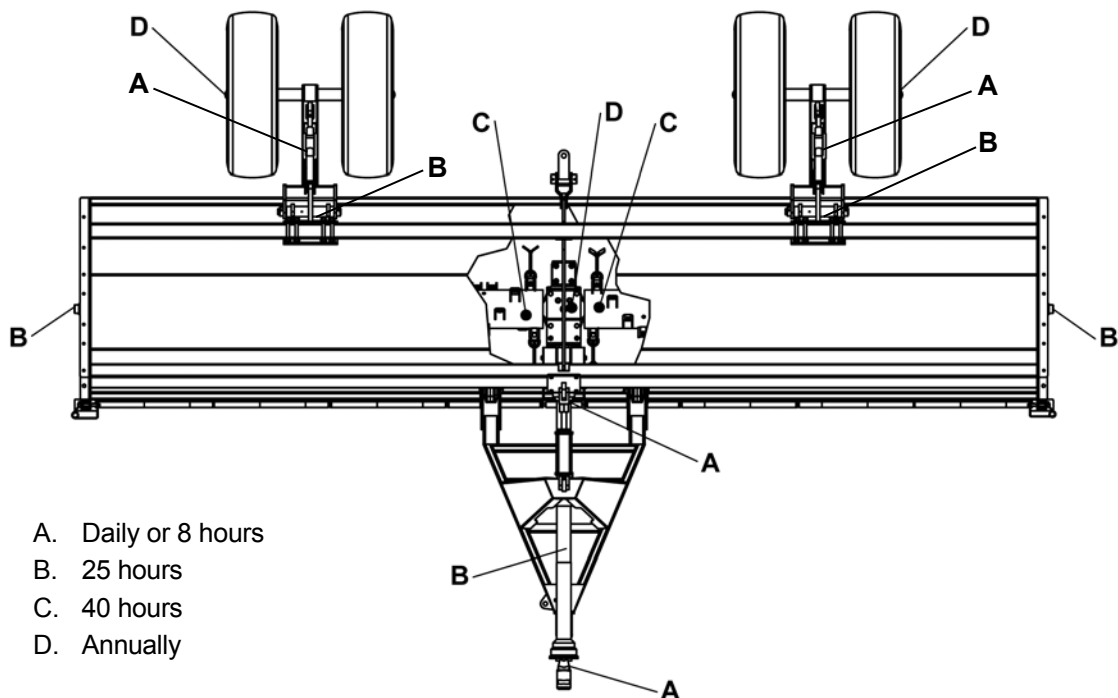

Figure 30. Lubrication Points

Service & Maintenance *Continued*

Daily or every 8 hrs of operation:

1. Check gearbox daily or every 8 hours of operation. See Figure 31 for gearbox oil fill location

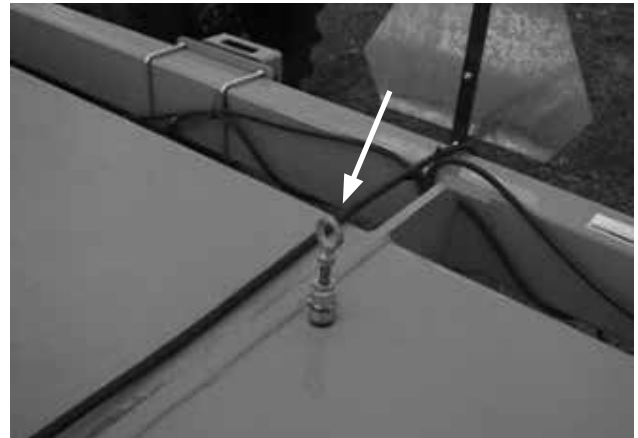

Figure 31. Gearbox Oil Fill Location

Every 25 hrs of operation:

1. Lubricate PTO driveline telescoping section (1 location, Position B, Figure 30).
2. Lubricate rotor end bearings. See Figure 32.



Figure 32. Rotor End Bearing Lubrication Point

3. Lubricate wheel strut pivots (3 to 5 locations). See Figure 33.



Figure 33. Wheel Strut Pivot Bearing Lubrication Points

Service & Maintenance *Continued*

Every 40 hrs of operation:

1. Lubricate rotor drive hubs next to the couplers on underside of unit (2 locations). See Figure 34.
2. Grease the drive hubs with 10 to 20 shots. You may use extra grease only on drive hubs.

Annually

1. Change gearbox oil. Refill with SAE 85W90 gear oil. See Figure 34.

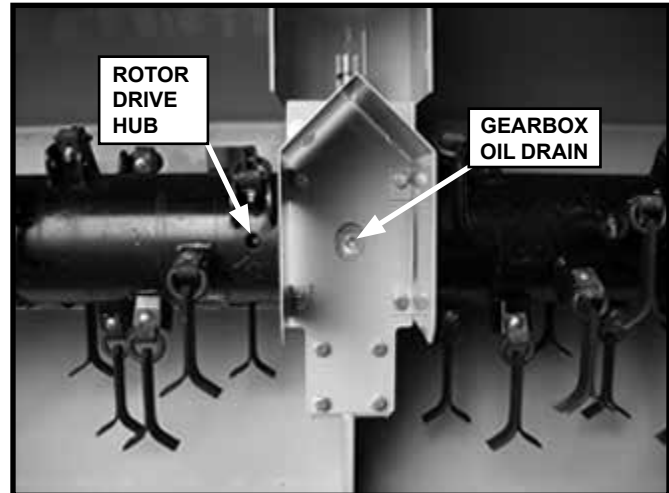

Figure 34. Rotor Drive Hub Lubrication Points & Gearbox Oil Drain Location

2. Repack wheel bearings. See Figure 35.



Figure 35. Wheel Bearings

3. Lubricate ratchets as necessary (2 locations each ratchet). See Figure 36.

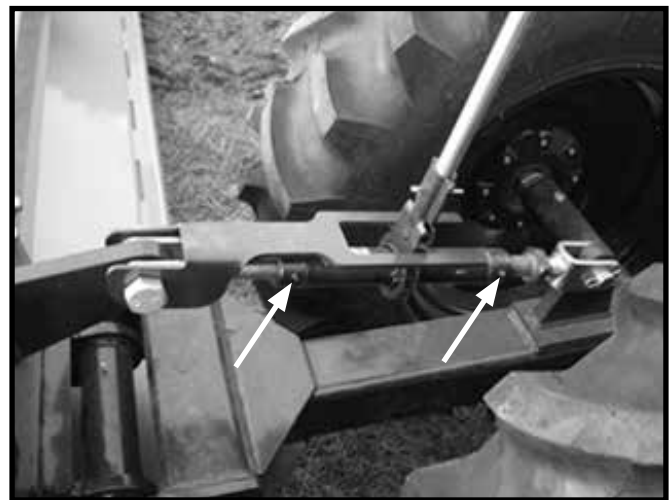

Figure 36. Ratchet Lubrication Points

Service & Maintenance *Continued*

Lubrication Service Record

NOTE: See prior pages for details.
Copy this page to continue service record.

✓ = CHECK
L = LUBRICATE

C = CHANGE
R = REPACK

Date:	Serviced By:	8 Hours or Daily					25 Hours		40 Hours		Annually		
		L	✓	L	L	L	L	L	L	C	R	L	
		PTO Driveline	Gearbox Oil Level	PTO Driveline (Telescope Section)	U-Joint	Overrunning Clutch	Rotor End Bearing	Wheel Mounting Tube Bearings	Rotor Inner Bearing		Gearbox Oil	Wheel Bearings	Ratchets

Service & Maintenance *Continued*

ACCEPTABLE OIL LEAKAGE FROM GEARBOX

Not all gearbox oil leakage or seepage is serious.

IMPORTANT

- Gearbox oil seepage is acceptable if
 1. Oil covers less than a 3-inch diameter area around the shaft seal area (see Figure 37).
 2. Oil covers 4 inches around the vent or drain plugs (see Figure 37).

If oil covers an area larger than that described in 1 & 2, do the following:

- a. Check gearbox oil level. If it is low, fill to proper level.
- b. Clean oily area of gearbox. Use a degreaser to remove all oil.
- c. Closely monitor gearbox for 10 hours of operation. Check oil level often.
- d. If after 10 hours of operation oil covers less than area described in 1 & 2 above, leakage is acceptable.

NOTE: Warranty only covers oil leakage that is in excess of above limits.

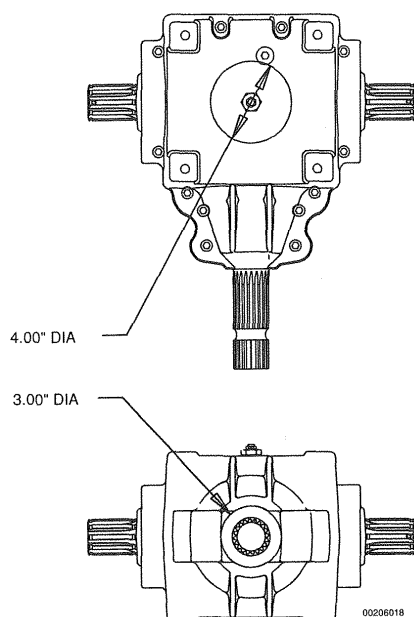

Figure 37. Acceptable Oil Leakage

CHANGING GEARBOX OIL

Although gearbox oil never wears out, dust, dirt, and moisture can enter through the breather during operation. These contaminants must be removed once a year to ensure a long life for working components. In very dusty or dirty conditions, change the oil twice a year.

1. Clear area of bystanders, especially children.
 2. Shut off tractor, place all controls in neutral, set parking brake, remove key, and wait for all moving parts to stop.
 3. Raise the unit to provide access to underside. Place safety stands or large blocks under frame.
 4. Disconnect PTO driveline and hydraulic lines.
 5. Place a pan under drain plug. Remove drain plug and dip stick plug (see Figure 38).
 6. Allow gearbox to drain for 10 minutes.
- NOTE:** To remove the most contaminants, drain oil when gearbox is hot.
7. Re-install and tighten drain plug.
 8. Dispose of used oil in an approved container.
 9. Add SAE 85W90 gear oil through the dip stick cover. Use the dip stick to check the oil level (Figure 39) and add oil accordingly.
 10. Re-install and tighten fill plug.
 11. Reconnect PTO driveline and hydraulic lines.
 12. Remove blocks or safety stands.

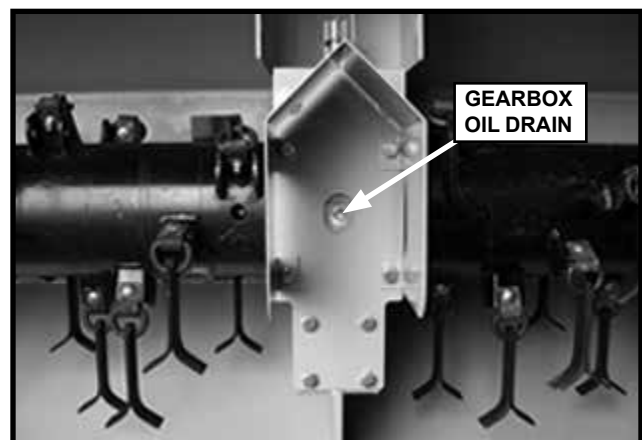

Figure 38. Drain Plug (underside of unit)



Figure 39. Dipstick Location

SETTING RATCHETS

Mechanical ratchets provide height setting for the unit. To set ratchets, follow this procedure:

1. Clear the area of bystanders, especially children.
2. Turn the turnbuckle to achieve the desired ratchet length (see Figure 39).
3. Repeat Step 2 with other ratchets.

WHEEL SPACING

The rear wheels can be adjusted for alignment with crop rows.

1. Clear the area of bystanders, especially children.
2. Shut off tractor, place all controls in neutral, set parking brake, remove key, and wait for all moving parts to stop.
3. Use a jack with sufficient capacity to lift the frame.
4. To determine wheel spacing, measure from the center line of the unit. Mark positions on the frame.
5. Lift frame until wheels have cleared the ground.
6. Place safety stands or large blocks under the frame.
7. Loosen mounting bolts on one wheel assembly.
8. Slide assembly along the frame tube to new position (see Figure 40).
9. Tighten mounting bolts to specified torque level.
10. Remove safety stands or blocks.
11. Lower and remove jack.
12. Repeat with other wheel assembly.



Figure 40. Positioning Wheel Assembly

Service & Maintenance *Continued*

REPLACING FLAILS “L” KNIFE W/ D-RING



CAUTION

- **Do not handle blades with bare hands. Careless or improper handling may result in serious injury.**

The flails swing on D rings, which are sandwiched between clips and mounted to the flail tube with bolts. Regularly inspect the flails for wear or damage. To replace worn or damaged flails, follow this procedure:

1. Clear the area of bystanders, especially children.
2. Shut off tractor, place all controls in neutral, set parking brake, remove key, and wait for all moving parts to stop.
3. Disconnect driveline and hydraulic lines from the tractor.
4. Place safety stands or large blocks under the frame.
5. Loosen and remove the mounting bolt on the worn flail and its opposite on the other side of the rotor. Discard worn flails and their mounting hardware.
6. Replace with new flails and and mounting hardware (see Figure 41).

IMPORTANT

- **To maintain rotor balance, always replace opposite pairs of flails and mounting hardware.**
7. Tighten flail mounting bolt to its specified torque.
 8. Replace additional worn flails following Step 5 and Step 6.
 9. Remove safety stands or blocks from under frame.
 10. Lower unit and remove jack.
 11. Attach driveline and hydraulic line to tractor.

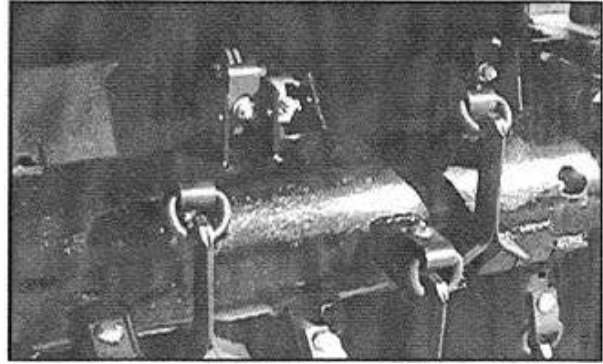

Figure 41. Flail Replacement

REPLACING RUBBER SHIELD FLAPS

Rubber shield flaps on the front of the unit deflect or prevent stones or debris from being ejected when operating unit. Replace if damaged or missing to provide a safe work environment. To replace, follow this procedure:

1. Clear the area of bystanders, especially children.
 2. Lower the unit to the ground, place all controls in neutral, shut off engine, set park brake, remove key, and wait for all moving parts to stop before dismounting.
- NOTE:** For 3-point hitch units, unhook to gain access to center flaps.
3. Remove the cotter pin from the end of the flap rod and pull rod until the flap comes off.
 4. Install new shield flap.
 5. Push rod through flaps and re-install cotter pin.

NOTE: Use only genuine Alloway parts when replacing flaps.

Service & Maintenance *Continued*



Figure 42. Front Rubber Shield Flaps

SERVICING ROTORS

The shredder rotors are dynamically balanced from the factory and should be maintained to keep them in balance and to prevent excessive wear on drive components.

IMPORTANT

- **Any vibration caused by missing knives or worn drive components can cause excessive damage to the shredder. Vibration is also transmitted through the PTO shaft to the tractor and will damage tractor**

When servicing rotors, follow this procedure:

1. Clear the area of bystanders, especially children.
2. Shut off tractor, place all controls in neutral, set park brake, remove key, and wait for all moving parts to stop.
3. Disconnect unit from the tractor.
4. Remove the PTO driveline from the unit.
5. Remove wheel arms.
6. Use a hoist, crane, or a frame of sufficient capacity to raise the front of the unit and allow back of unit to rest on a solid surface.
7. Leave lifting device attached while working on rotors to prevent tipping.
8. Remove knives. Wear heavy canvas or leather gloves to protect your hands.



CAUTION

- **Use a suitable lifting device of sufficient capacity. Use adequate personnel to handle heavy components.**

Removing components:

1. With unit raised (Step 6), support each end of rotor with crane or hoist.
2. Remove bearing locking collar (see Figure 44).
3. Remove 8 bolts holding bearing plate to body assembly.
4. Slide rotor out to disengage from the center drive hub.
5. Check drive hubs for wear and replace if necessary. If O-ring grease seal is cut or worn, replace it.
6. Remove gearbox if damaged.

Replacing components:

Place new stud bolts into gearbox, using Loctite®^a No. 271 or equivalent.

7. Remount gearbox.
 8. Insert outer shaft through end plate hole.
 9. Install drive hub to gearbox output shaft. Thoroughly clean both halves of the drive couplers and apply new grease to all gear teeth.
- NOTE:** When replacing flail tube, you will have to remove the grease zerk to allow air to purge from the coupler assembly. Then replace grease fitting and follow lubrication schedule.
10. Install bearing plate bolts and tighten to specified torque.

IMPORTANT

- **To keep drive hub bolts from loosening, use Loctite No. 271 or equivalent and special Hi-Collar lock washers.**
11. Re-install locking collar and tighten in the direction of rotation (see Figure 44).

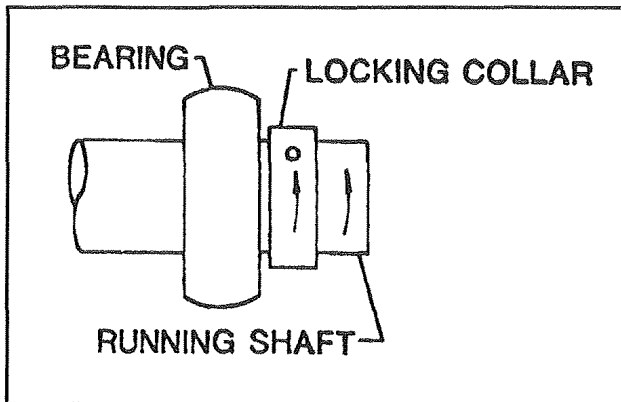

Figure 44. Locking Collar

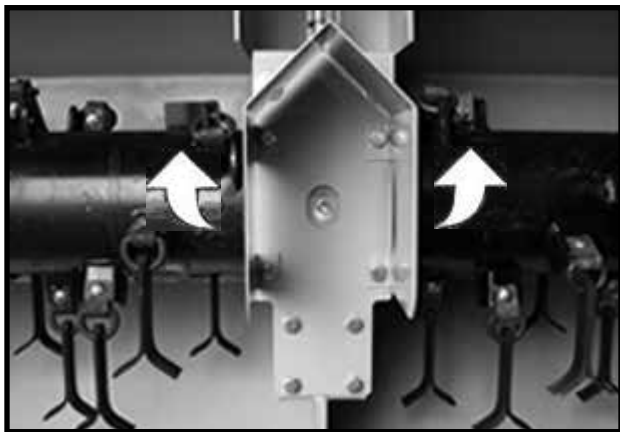

Figure 45. Rotor Direction of Rotation

REPLACING STUB SHAFT

1. Remove rotor (see Servicing Rotors, page 41).
2. Remove three 1/2 x 2-1/2 hex bolts in taper lock hub and re-install bolts in three threaded holes (see Figure 46).
3. Tighten bolts evenly to release taper lock hub from stub shaft.

NOTE: You may have to give a sharp blow directly to each bolt head to help the hub disengage.

4. Unscrew stub shaft from the rotor tube.
5. Install new stub shaft, reversing Steps 1-3.

SERVICING WEASLER MODULAR FRICTION CLUTCH

Tools Required

- 3/4" Socket wrench
- 8" Minimum C-clamps (2)
- 1/4" Hex Allen wrench
- Regular screwdriver or punch
- Duct tape or locking pliers with 3" throat minimum
- Hammer
- 1/2" sq. to 1"sq. barx 9"
- Scale or Vernier

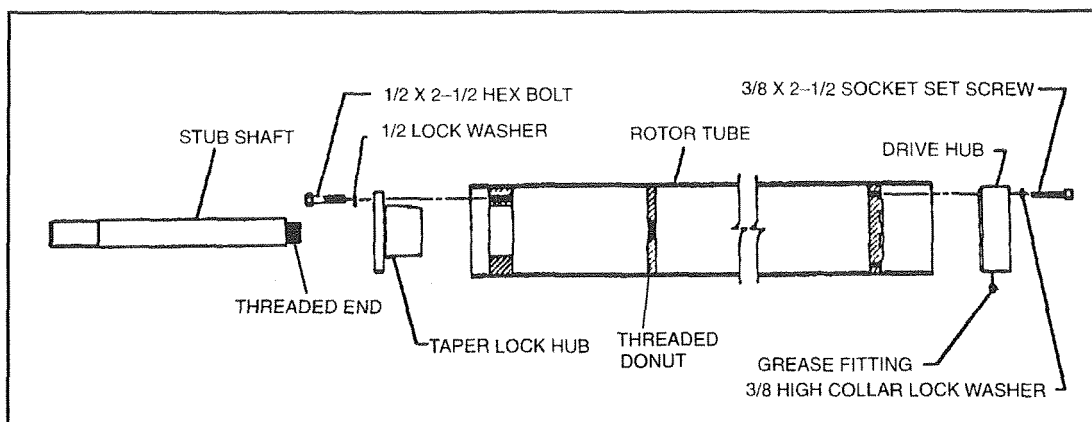

Figure 46. Stub Shaft Assembly

Service & Maintenance *Continued*

Breaking in the Clutch (Run In)

NOTE: All new clutches must be broken in (Run in) and any clutch that has not been used for approximately 60 days.

1. Shut off tractor and disengage PTO.
2. Disconnect driveline from the tractor PTO shaft.
3. Loosen the bolts on the outside diameter of the clutch until all bolts are just loose, then tighten all bolts 1/2 turn.
4. Attach the shredder to the tractor and the driveline to the tractor PTO. Stand clear of the unit.
5. Start tractor. Engage PTO clutch and run for a few seconds or until clutch visibly smokes.
6. Disengage PTO. Shut off tractor. Disconnect driveline from the tractor.
7. Tighten all bolts on the outside diameter of the clutch until the compression plate is tight against the housing.
8. Grease the fitting on the yoke, using Shell Super Duty or an equivalent lithium grease.
9. For an integral overrunning clutch, make sure clutch turns freely in one direction.

Removing the Driveline

1. Shut off tractor and disengage PTO.
2. Disconnect driveline from PTO shaft.
3. Remove the clamp bolts attaching the clutch to the shredder's input shaft.

NOTE: The shaft is heavy.

4. Grasp the clutch firmly with both hands and slide off the input shaft.

Rebuilding Friction Pack

Disassembly

1. Position clutch and universal joint assembly on a bench so that end is accessible.
2. Remove the long bolts on the outside of the housing that hold the friction pack together.
3. Remove the plate(s) and all internal components. Leave the yoke/hub intact.
4. Discard friction discs.
5. If rebuilding the overrunning clutch, refer to Rebuilding Overrunning Clutch, page 45, beginning with Step 2.

Inspection

6. Inspect the steel and iron parts for wear, warping, or cracks, and replace if necessary.
7. Inspect the yoke/hub for looseness. If there is more than .03 end play, replace.
8. Clean any rust or dust from the plate surfaces with a wire brush or steel wool.

Assembly

9. Into housing place one new friction disc, then separator plate, then second friction disc.
10. Add the pressure plate so that the flat surface rests on the friction disc. **NOTE:** The tangs on the plate must fall into the reliefs in the housing.
11. Add the disc spring so that its inside diameter contacts the fins of the pressure plate.
12. Assemble the compression plate and all the long bolts. Make sure all nuts rest in their pockets.
13. Tighten all long bolts to 30 lbs.-ft.

Service & Maintenance *Continued*

Rebuilding Overrunning Clutch

Disassembly

1. Remove the four bolts that secure the friction pack. Remove the friction pack.
2. Using screwdriver and pliers, remove the retaining ring that holds the overrunning clutch together.
3. Slide the collar and washer off the clutch hub, noting the orientation of the collar for reinsertion.
4. Remove and discard the keys and leaf springs.

Inspection

5. Inspect the steel parts for wear and replace if necessary.
6. Inspect the yoke/hub for looseness. If there is more than .03 end play, replace.
7. Using screwdriver, scrape any hardened grease from the overrunning key pockets.

Assembly

8. Using Shell Super Duty grease or equivalent, inject one grease gun pump into each key pocket. Evenly wipe two more pumps over the overrunning surface.
9. Press a new leaf spring into each pocket. The ends should touch the bottom of the pockets.
10. Add new keys. With one hand, hold the two keys in the pockets.
11. Slide the collar onto the hub, orienting collar correctly.
12. Add washer.
13. Install retaining ring.
14. Make sure clutch spins freely and only in correct direction.
15. Reassemble friction pack.

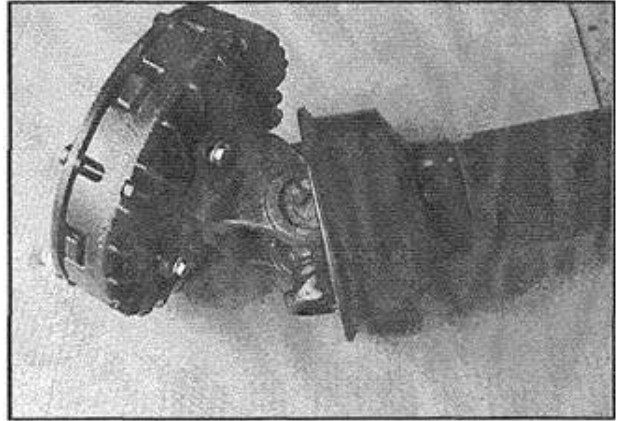

Figure 47. Weasler Modular Friction Clutch

MOUNTING CLUTCH ONTO SHREDDER

1. Mount and bolt the clutch hub onto the shredder input shaft. Make sure shaft and clutch grooves line up.
2. Re-install any shielding that was moved or removed.
3. Run the clutch before using. Refer to Breaking in the Clutch (Run In), page 44.

TROUBLE SHOOTING

The Alloway Center Drive Shredder uses swinging flails to pick up and shred crop residue left in the field. It is a simple and reliable system that requires minimal maintenance.

The following table lists problems, causes, and solutions that you may encounter. If you encounter a problem that is difficult to solve even after reading through this table, please call your local Alloway dealer. When calling, please have this manual and your unit's serial number ready.

PROBLEM	CAUSE	SOLUTION
Shredder doesn't track	Poor wheel spacing	Set wheels in center of crop rows
	3 Point not set	Set 3-point hitch in non-sway position
	Shredder not level	Level shredder (see Set Operating Height, page 23)
	Irrigation furrows not even	Set wheels against seed bed (see Setting Outer Trailing Wheels, page 26)
Shredder doesn't follow ground contour	3 Point not set	Set 3 point in float position See tractor manual to set Load Sensing hydraulic system
	Shredder too high	Set shredder closer to ground
	Irrigation furrows not even	Set wheels against seed bed
Shredder vibrates	Driveline doesn't telescope	Remove, disassemble, and clean telescoping joint
	Rotor out of balance	Replace damaged or broken flails and flails 180 degree opposite Check for missing balance weights or rebalance
Debris being thrown out from under shredder	Shredder set too low	Raise shredder
	Knives excessively worn	Replace knives
	Rubber shields missing	Replace flaps immediately
Crop residue left	Travelling too fast	Slow travel speed
	Shredder too high	Lower shredder
	Improper flails	Change flails
	Crop residue strip left in shredder center	Add center cutter or divider
Windrowing centers or ends	Light, fluffy residue expelled from unit with air flow	Add optional baffles

WORKSHEET FOR CONTOUR FLAIL PATTERNS

NOTE: Use the same knives on opposite clips to keep balanced.

30" ROWS

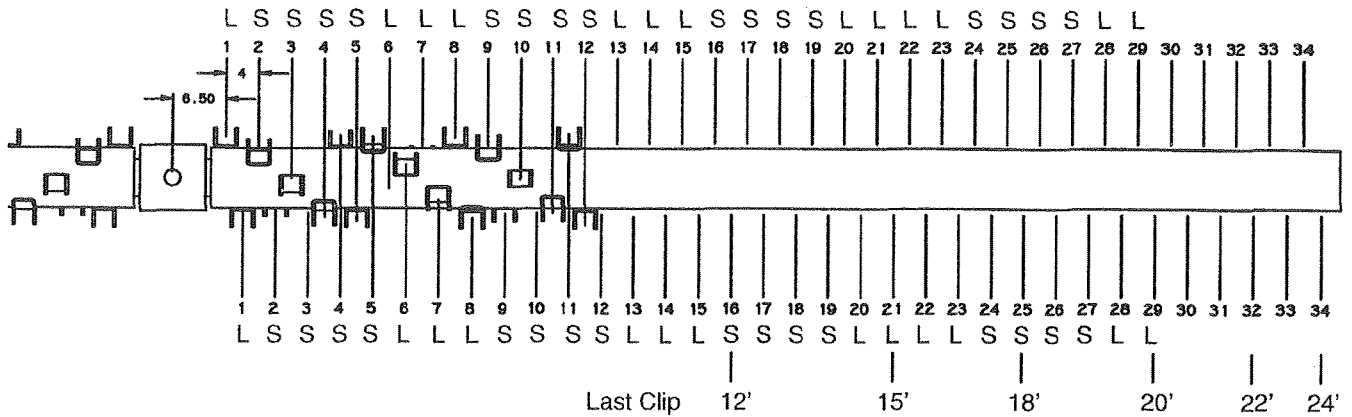

34" ROWS

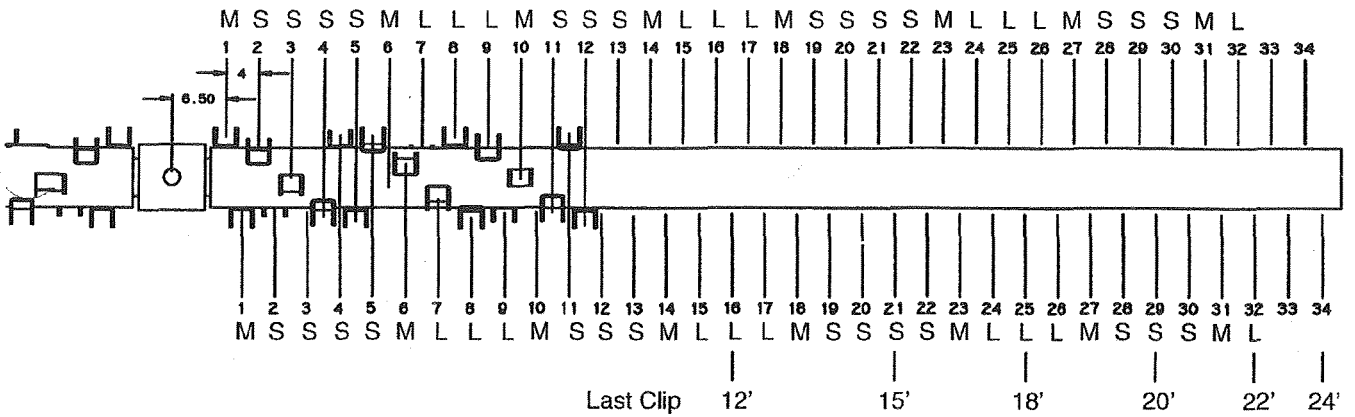

36" ROWS

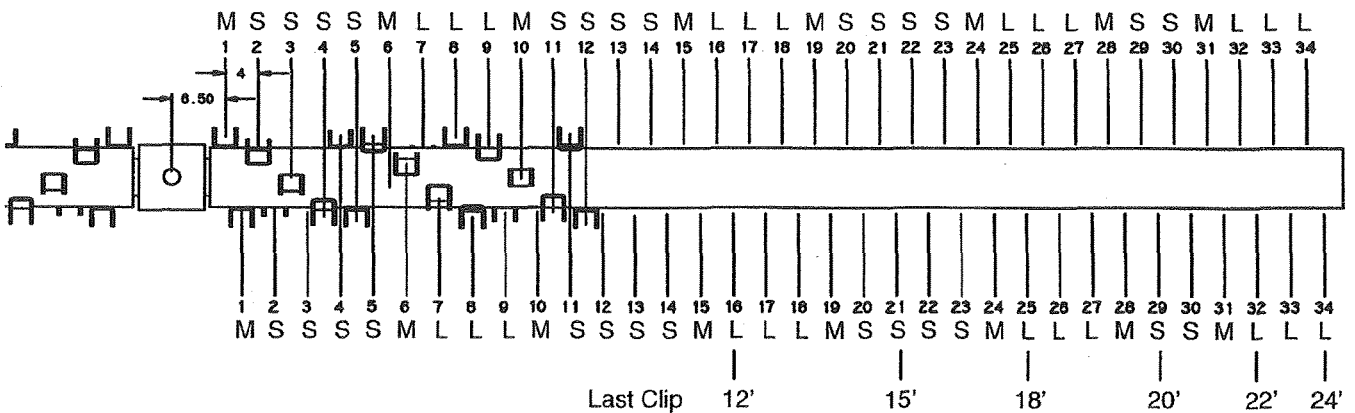

WORKSHEET FOR CONTOUR FLAIL PATTERNS

NOTE: Use the same knives on opposite clips to keep balanced.

38" ROWS

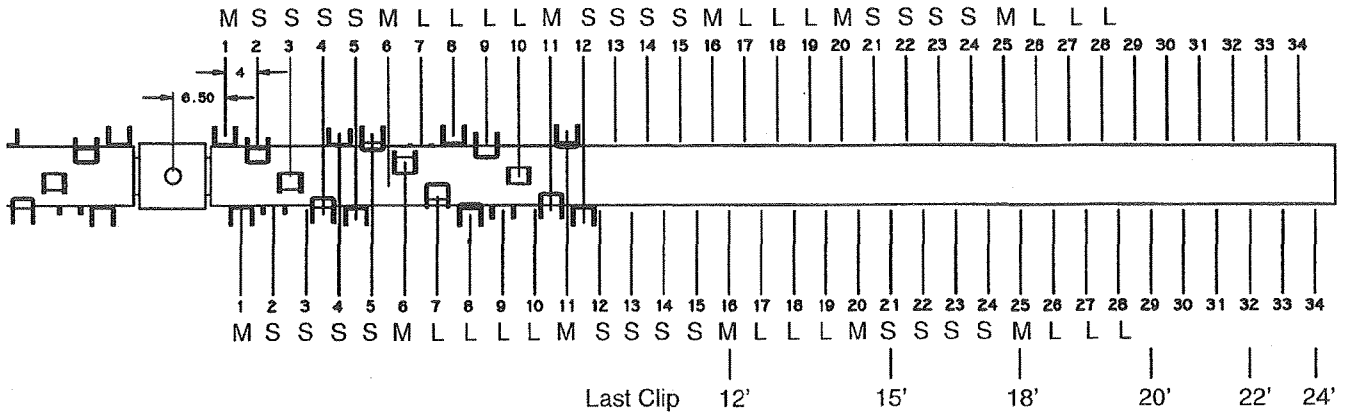

40" ROWS

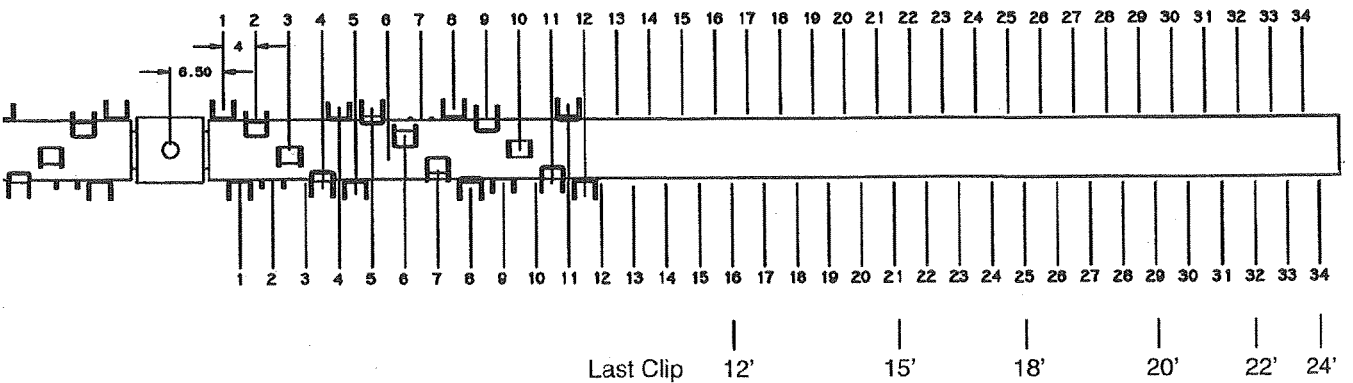
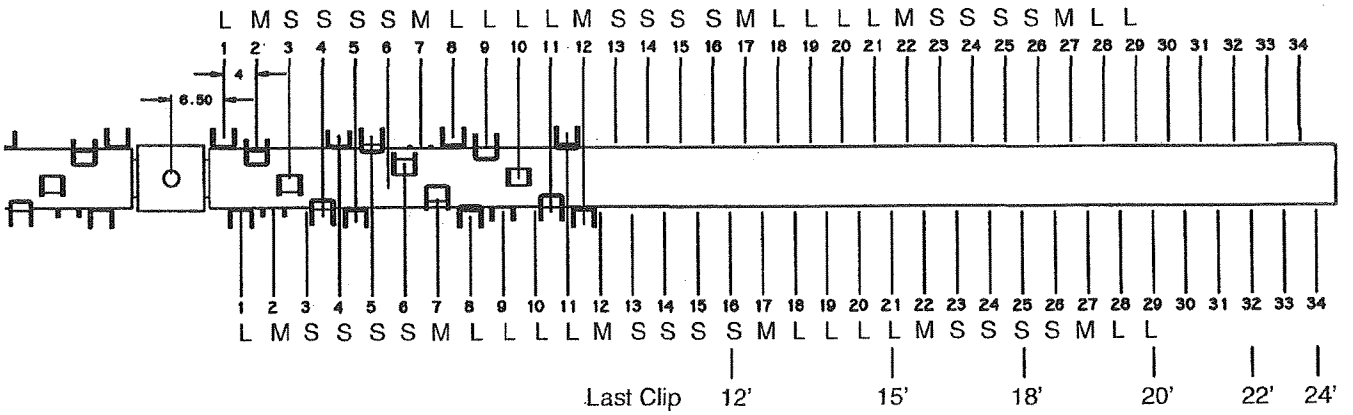

ASSEMBLY



WARNING

- Do not allow bystanders in the area when operating, attaching, removing, assembling, or servicing equipment.
- Do not handle blades with bare hands. Careless or improper handling may result in serious injury.



CAUTION

- Always wear relatively tight and belted clothing to avoid entanglement in moving parts. Wear sturdy, rough-soled work shoes and protective equipment for eyes, hair, hands, hearing, and head; and respirator or filter mask where appropriate.



WARNING

- Keep hands and body away from pressurized lines. Use paper or cardboard, not hands or other body parts to check for leaks. Wear safety goggles. Hydraulic fluid under pressure can easily penetrate skin and will cause serious injury or death.
- Make sure that all operating and service personnel know that if hydraulic fluid penetrates skin, it must be surgically removed as soon as possible by a doctor familiar with this form of injury or gangrene, serious injury, or death will result. **CONTACT A PHYSICIAN IMMEDIATELY IF FLUID ENTERS SKIN OR EYES. DO NOT DELAY.**
- Check that all hardware is properly installed. Always tighten to torque chart specifications unless instructed otherwise in this manual.

Assembly Continued



WARNING

- Do not allow bystanders in the area when operating, attaching, removing, assembling, or servicing equipment.



CAUTION

- Always wear relatively tight and belted clothing to avoid entanglement in moving parts. Wear sturdy, rough-soled work shoes and protective equipment for eyes, hair, hands, hearing, and head; and respirator or filter mask where appropriate.
 - Use a suitable lifting device of sufficient capacity. Use adequate personnel to handle heavy components.
1. Open the crate and cartons containing the attaching components and mounting hardware.
 2. Use the packing list to check that all parts have been shipped.
 3. Raise the rear of the unit.
 4. Place safety stands or large blocks under the frame.
 5. Measure the wheel spacing from the center of the unit. Mark the frame.
 6. Install the wheel assembly to the mounting tube (Figure 51). **If equipped with caster wheels, verify that there is enough clearance for casters to rotate without hitting each other.** Failure to do so will result in tire damage. Offset struts may be required (see Wheel Assembly parts page 64).
 7. Tighten mounting bolts to their specified torque.
 8. Install PTO driveline by sliding the yoke with the slip clutch over the input shaft (Figure 53).
 9. Tighten mounting bolts to its specified torque.
 10. Install front parking stands, using pin.



Figure 51. Wheel Assembly Installed



Figure 53. Gearbox Input Shaft

3-Point Units:

1. Fasten floating top mast (1) to shredder, using four 1 x 6" hex bolts and top lock nuts as shown in Figure 52. Be sure mast is free to slide forward.
2. Attach one upper 3-point 1 x 5" bolt, bushing, lock washer, and hex nut (2).
 - a. **Category II:** Fasten components in the lower hole in floating top mast.
 - b. **Category III:** Fasten components in the upper hole in floating top mast.
3. Fasten lower 3-point.

Assembly Continued

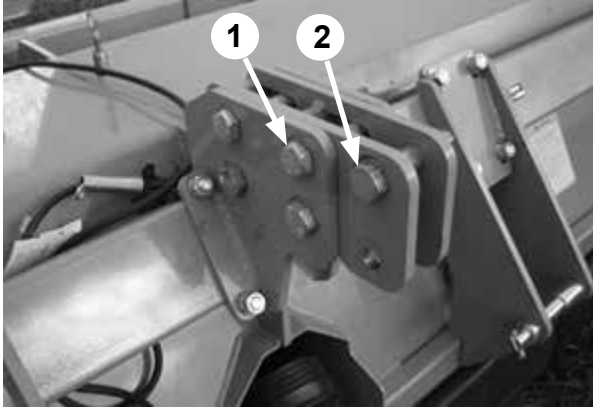

Figure 52. Floating Top Mast Installed

Pull-Type Hitch:

1. Mount hitch to frame using pins and bolts.
2. Install ratchet. Be sure to install retaining pins.
3. Attach Ear Plate to upper tube using U-Bolts and hardware provided.
4. Attach clevis to hitch, using 1-1/4" pin and 3/8 x 3-1/2" cotter pins.
5. Attach tow chain to hitch. See Figure 56 for completed assembly.



Figure 54. Pull-type Hitch Installed

Manual Storage Tube

1. Mount the tube clamp to the shredder side sheet, using two 1/4" self-tapping screws. Mounting holes are located above the bearing plate (see Figure 55).
2. Place the tube in the clamp with the cap facing forward.

NOTE: Keep the Owner's Manual with the shredder at all times.

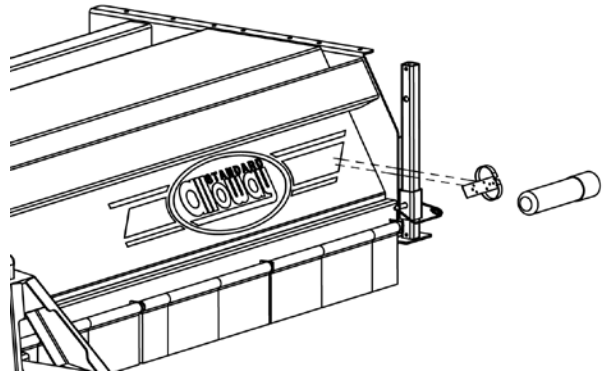

Figure 55. Manual Storage Tube Assembly

Assembly Continued

Safety Light Kit Installation

(Non-End Tow)

1. Remove all components from shipping carton. Make sure that all required hardware is included.
2. Attach dual safety lights (Figure 59) to their bases using 1/4 NC x 1" hex bolts, washers and nuts provided. Make sure that light lenses are in the correct position in relation to direction of equipment travel: amber lenses on the outside, red lenses on the inside facing rear of shredder.
3. Plug ends of wiring harness into corresponding plugs of the light units (Note: left side of wishbone harness is labeled "Left").
4. Run wiring harness along top of shredder and secure with enclosed adhesive-backed clamps (5) approximately every two feet.



Figure 58. Safety Light Kit Installed

5. Connect 7-pin connector of wiring harness to tractor and test all light functions before actual use.

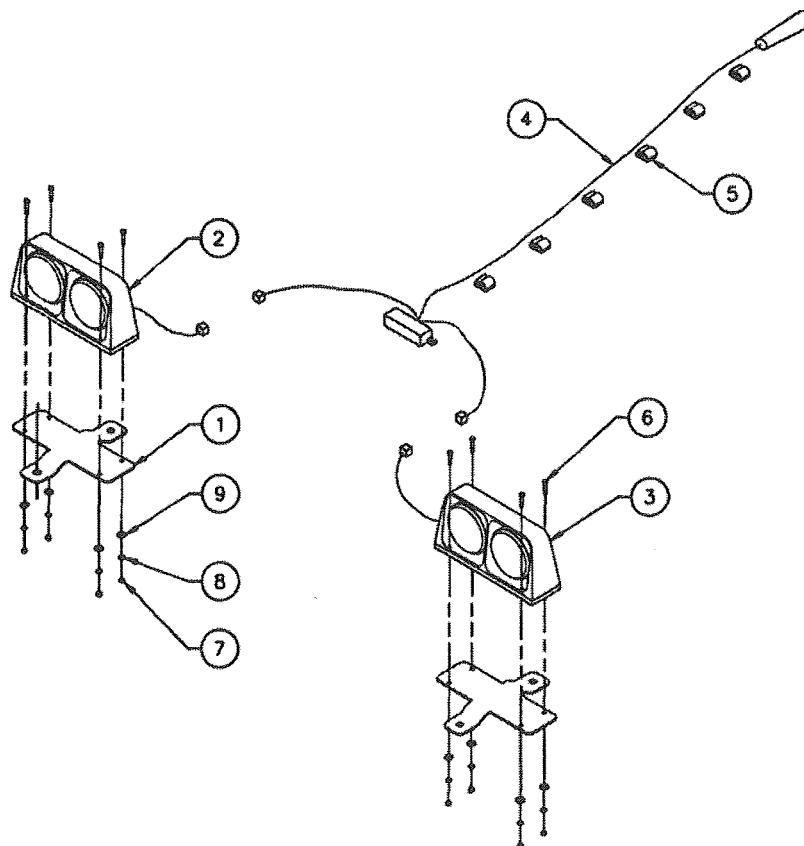

- | | | |
|-----------------------|------------------------|------------------------|
| 1. Dual Light Bracket | 2. Dual Lamp, 4-Pin LH | 3. Dual Lamp, 4-Pin RH |
| 4. Wiring Harness | 5. Clamp | 6. 1/4 NC x 1 Hex Bolt |
| 7. 1/4 NC Nex Nut | 8. 1/4 Lock Washer | 9. 1/4 Flat Washer |

Figure 59. Safety Light Kit Diagram

Assembly Continued

Dual Safety Light Assembly

(End Tow)

1. Remove all components from shipping carton. Make sure that all required hardware is included.
2. Install light bar on end of shredder that does not have end transport hitch attached. Use 1/2 NC x 1-1/2" hex bolts, washers and nuts (3 each).
3. Attach Slow Moving Vehicle sign (1) to upright bracket using 1/4 NC x 1" hex bolts, washers and nuts (2 each).
4. Attach dual safety lights (5 & 6), Figure 62, to their bases using 1/4 NC x 1" hex bolts (9, 10, 11, 12). Make sure that light lenses are in the correct position in relation to direction of equipment travel: amber lenses on the outside, red lenses on the inside facing rear of shredder.
5. Attach lighting module of wiring harness (7) to mount weld (3) using self-drilling Tek screws (17) (2 each). Plug ends of wiring harness into corresponding plugs of the light units (Note: Left side of wishbone harness is labeled "Left").
6. Run wiring harness along top of shredder to front (end transport end) and secure to top with adhesive-backed clamps (8) approximately every 2 feet.
7. Connect 7-pin connector of wiring harness to tractor and test all light functions before actual use.
8. For field use, the tubes will be at their shortest length; during highway transport, they will be at their widest position. Make sure that tubes are locked in place with pins at all times.

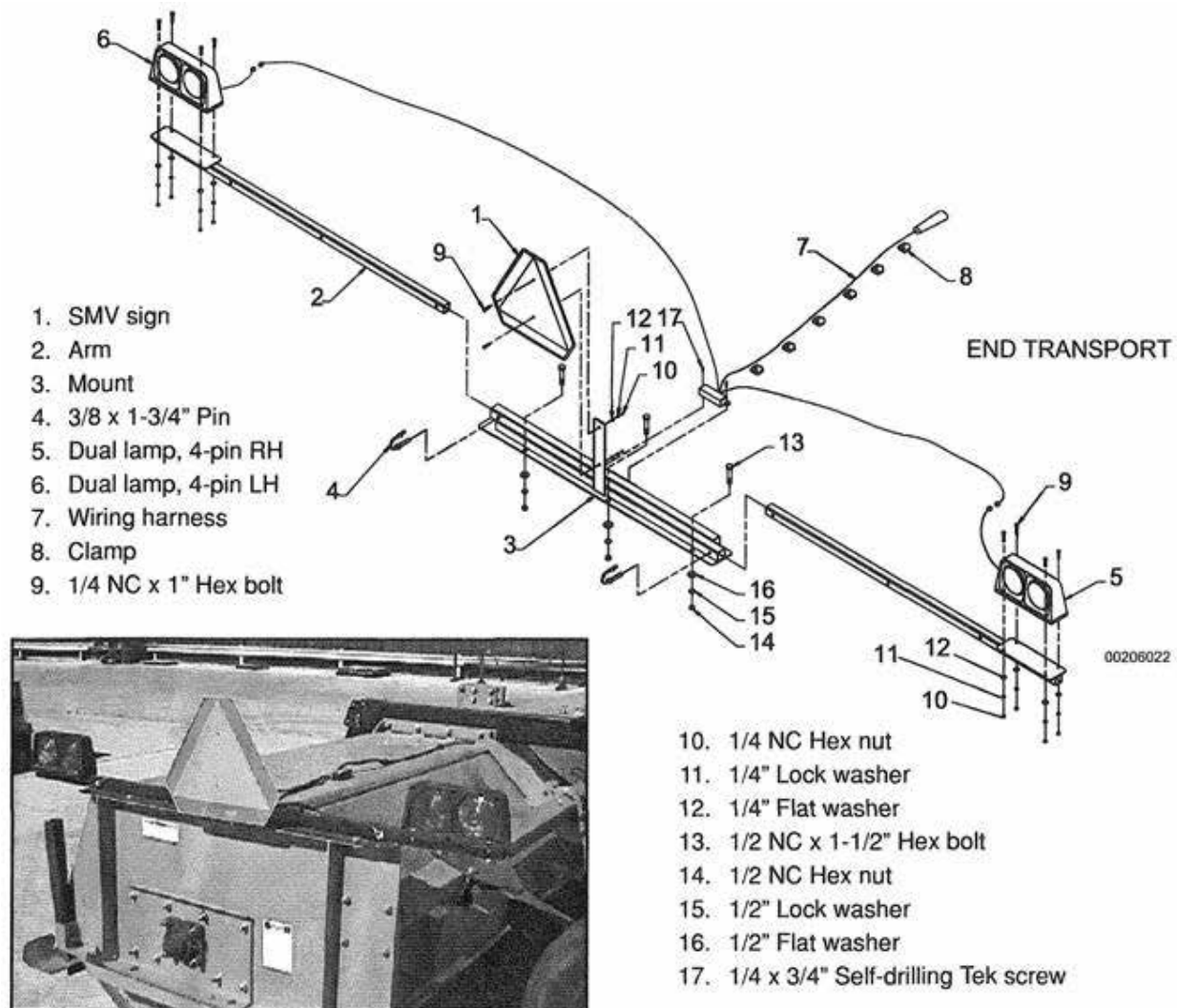

Figure 61. Dual Safety Light Kit Installed

Figure 62. Dual Safety Light Kit



PARTS INDEX

CENTER DRIVE SHREDDER

FRAME COMPONENTS	52 - 53
FLAIL TUBE COMPONENTS	54 - 55
3-POINT HITCH COMPONENTS	56
PULL TYPE HITCH COMPONENTS	57
RIGID STRUT - DUAL (LARGE WHEELS)	58 - 59
RIGID STRUT - DUAL (MEDIUM WHEELS)	60 - 61
LIGHT KIT COMPONENTS	62
GEARBOX COMPONENTS	63
HUB & SPINDLE ASSEMBLY COMPONENTS	64 - 65
2-POINT & 3-POINT PTO COMPONENTS	66
PULL-TYPE PTO COMPONENTS	67
TORQ MASTER CLUTCH COMPONENTS	68 - 69

CENTER DRIVE FLAIL SHREDDER FRAME COMPONENTS

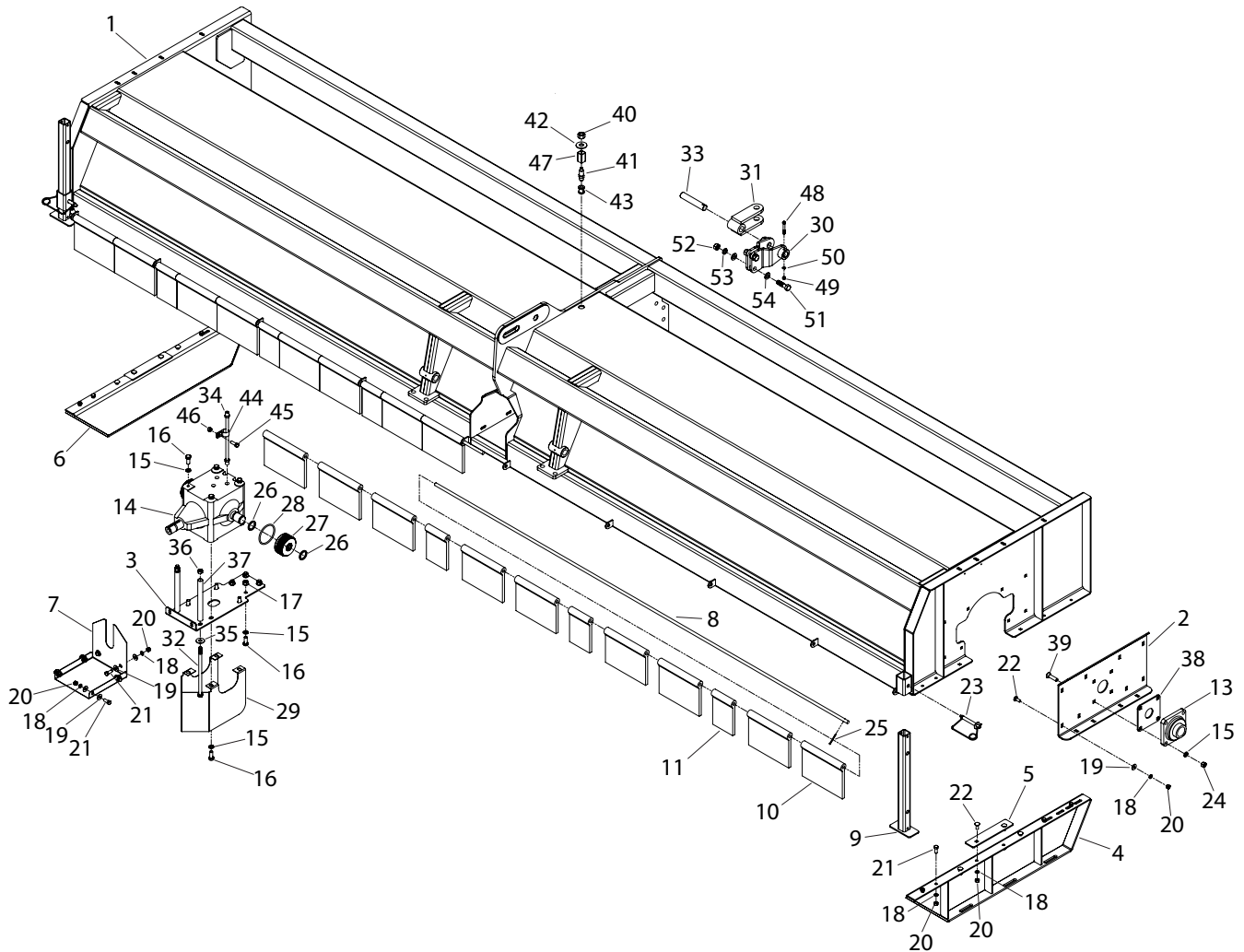

ITEM NO.	PART NUMBER	DESCRIPTION	QTY.
1	507-2-0062	12' SHREDDER BODY WELD - GEAR DRIVE	1
	507-2-0063	15' SHREDDER BODY WELD - GEAR DRIVE	
	507-2-0064	18' SHREDDER BODY WELD - GEAR DRIVE	
	507-2-0065	20' SHREDDER BODY WELD - GEAR DRIVE	
	507-2-0066	22' SHREDDER BODY WELD - GEAR DRIVE	
	507-2-0305	24' SHREDDER BODY WELD - GEAR DRIVE	
	507-2-0067	25' SHREDDER BODY WELD - GEAR DRIVE	
	507-2-0068	27' SHREDDER BODY WELD - GEAR DRIVE	
	507-2-0069	30' SHREDDER BODY WELD - GEAR DRIVE	
	2	507-3-0023	
3	507-3-0120	BOTTOM GEARBOX PLATE	1
4	507-2-0018	SKID PLATE WELD-LH	1
5	507-3-0046	SPACER PLATE - SKID	2
6	507-2-0019	SKID PLATE WELD - RH	1
7	507-3-0121	CLUTCH SHIELD	1
8	507-3-0220	FLAP ROD - 12'	2
	507-3-0221	FLAP ROD - 15'	
	507-3-0222	FLAP ROD - 18'	
	507-3-0054	FLAP ROD - 20'	
	507-3-0128	FLAP ROD - 22'	
	507-3-0591	FLAP ROD - 24'	

CENTER DRIVE FLAIL SHREDDER FRAME COMPONENTS

ITEM NO.	PART NUMBER	DESCRIPTION	QTY.
	507-3-0196	FLAP ROD - 25'	
	507-3-0209	FLAP ROD - 27'	
	507-3-0223	FLAP ROD - 30'	
9	507-2-0021	PARKING STAND WELD	2
10	505-3-1089	FLAP SHIELD 12"	
11	505-3-1097	FLAP SHIELD 6"	
12	505-3-0868	FLAP SHIELD 3-1/2"	
13	901-01386	BEARING - 2.19 4-BOLT ECC. LOCK	2
14	903-15566	G-BOX - SUPERIOR MODEL R800	1
15	900-11015	WASHER, LOCK, 5/8	20
16	900-01341	HEX BOLT 5/8 NC X 1-1/2 NC GR5 ZP	12
	507-3-0630	STUD, GEARBOX, 5/8 NC	4
17	900-06145	5/8 WHIZ NUT	4
18	900-11013	WASHER, LOCK 1/2	38
19	900-11035	1/2 FLAT WASHER	28
20	900-06009	NUT HEX 1/2 UNC	38
21	900-01223	1/2 NC X 1-1/4 HEX BOLT GR 5	14
22	900-01750	CARRIAGE BOLT 1/2 NC X 1 1/4 GD 5 ZP	24
23	900-42054	LOCK UP PIN	2
24	900-06013	NUT HEX 5/8 UNC	8
25	900-23043	3/16 X 1 1/2 COTTER PIN	2
26	900-39030	RETAINING RING 600 SERIES	4
27	500-3-0338	COUPLER	2
28	901-09126	O-RING, FLAIL COUPLER	2
29	507-3-0157	CENTER DIVIDER PLATE - MODEL 800 GEARBOX (Optional)	1
30	507-2-0016	REAR HITCH BASE WELD	1
31	507-2-0017	REAR HITCH WELD	1
32	900-01393	HEX BOLT- 5/8 X 12 UNC ZP	1
33	507-3-0042	PIN - REAR HITCH	1
34	905-19224	DIPSTICK TUBE, FLEXIBLE R800	1
35	900-11037	WASHER, FLAT 5/8"	2
36	900-06508	NUT, TOP LOCK 5/8"	2
37	507-3-0224	SPACER TUBE - GEARBOX	2
38	507-3-0242	UHMW SEAL PLATE - 2-3/16" BEARING	2
39	900-01788	BOLT, CRG 5/8"	8
40	900-06017	NUT, HEX 7/8" UNC	1
41	507-3-0268	DIPSTICK SUPPORT BRACKET	1
42	900-11039	WASHER, FLAT 7/8"	1
43	905-01189	COUPLING 1/2" NPT S/S	1
44	900-31045	HOSE CLAMP, 1-1/4"	1
45	900-01225	1/2" NC X 1-1/2" HEX BOLT GR 5	1
46	900-06504	NUT, TOP LOCK 1/2"	1
47	507-3-0342	SPACER - DIPSTICK	1
48	900-01123	BOLT, HEX HEAD 3/8" X 2-3/4" NC	1
49	900-06005	NUT, HEX 3/8"	1
50	900-11011	WASHER, LOCK 3/8"	1
51	900-01409	BOLT, HEX HEAD 3/4" X 2-3/4" NC	2
52	900-06015	NUT, NEX 3/4"	2
53	900-11017	WASHER, LOCK 3/4"	2
54	900-11038	WASHER, FLAT 3/4"	4

FLAIL TUBE COMPONENTS

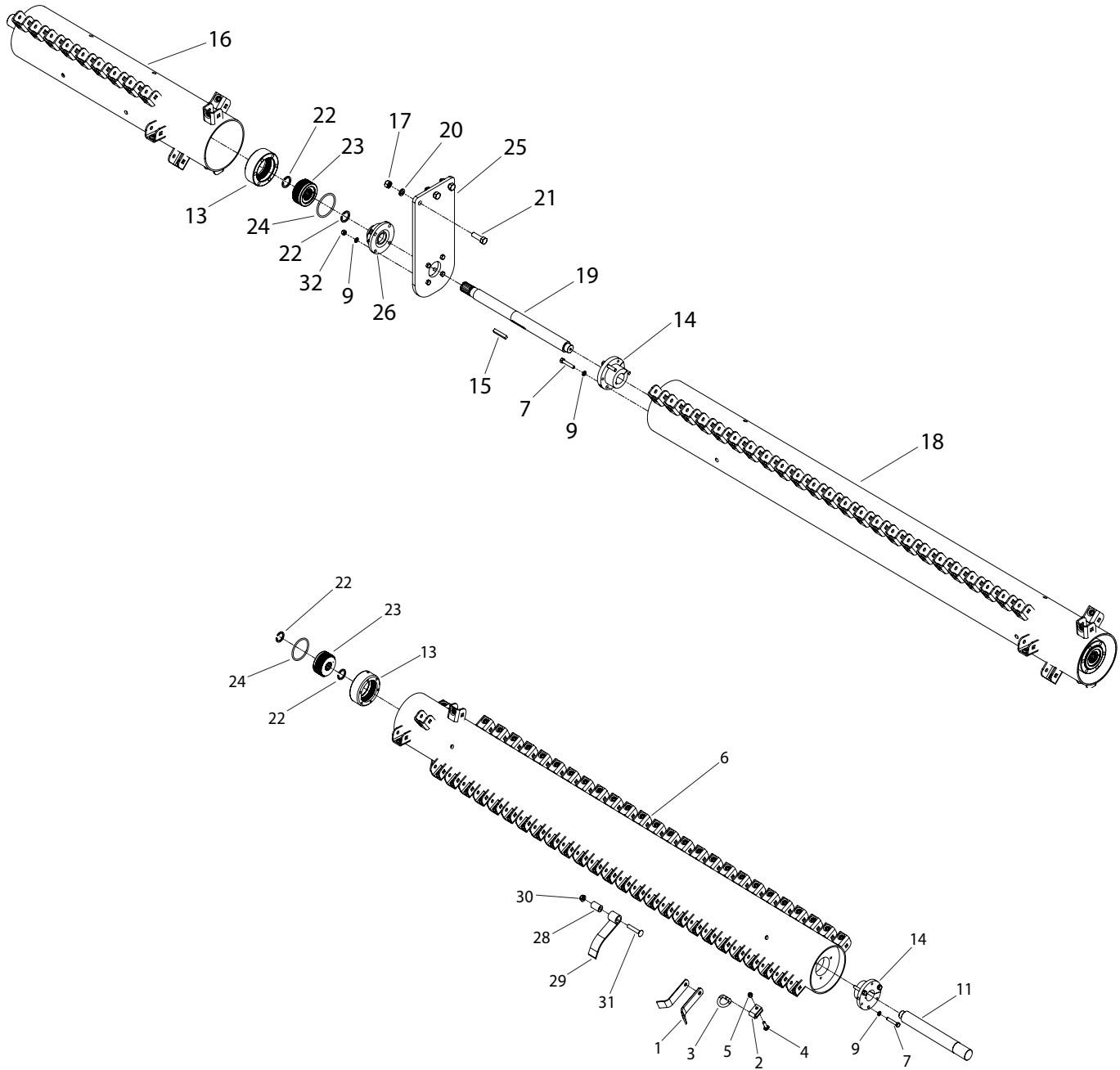

ITEM NO.	PART NUMBER	DESCRIPTION	QTY.
1	505-3-0001	STEEL L-KNIFE LONG	
	505-3-0224	STEEL L-KNIFE LONG (DURAFACE)	
2	507-3-0109	D-RING CLIP	
3	505-3-0008	D-RING	
4	900-01752	CARRIAGE BOLT 1/2 NC X 1 3/4 GD 5 ZP	
5	900-06504	NUT, HEX 1/2 NC TOP LOCK NUT ZP	
6	507-2-0131	12' FLAIL TUBE WELDMENT - LH	1
	507-2-0130	12' FLAIL TUBE WELDMENT - RH	1
	507-2-0133	15' FLAIL TUBE WELDMENT - LH	
	507-2-0132	15' FLAIL TUBE WELDMENT - RH	
	507-2-0135	18' FLAIL TUBE WELDMENT - LH	

FLAIL TUBE COMPONENTS

ITEM NO.	PART NUMBER	DESCRIPTION	QTY.
	507-2-0134	18' FLAIL TUBE WELDMENT - RH	
	507-2-0075	20' FLAIL TUBE WELDMENT - LH	
	507-2-0076	20' FLAIL TUBE WELDMENT - RH	
	507-2-0080	22' FLAIL TUBE WELDMENT - LH	
	507-2-0079	22' FLAIL TUBE WELDMENT - RH	
	507-2-0308	24' FLAIL TUBE WELDMENT - LH	
	507-2-0309	24' FLAIL TUBE WELDMENT - RH	
	507-2-0113	25' FLAIL TUBE WELDMENT - LH	
	507-2-0114	25' FLAIL TUBE WELDMENT - RH	
7	900-02526	BOLT HEX 1/2 X 2-3/4 GR 5	6
8	903-08420	TYPE E HUB 2-3/16 BORE	1
9	900-11013	WASHER, LOCK 1/2	5
10	507-2-0004	INNER DONUT WELD - 10" FLAIL TUBE	1
11	507-3-0012	STUB SHAFT - 2.19 DIA	1
12	507-3-0013	MOUNTING HUB - TYPE E HUB	1
13	500-3-0345	DRIVE SLEEVE, OUTER	2
14	500-3-1060	HUB 2" TYPE "E" W/KW	1
15	100-3-3331	KEY - 1/2 X 1/2 X 3	1
16	507-2-0118	FLAIL TUBE WELDMENT - 27' OUTER LH	1
	507-2-0119	FLAIL TUBE WELDMENT - 27' OUTER RH	
	507-2-0137	FLAIL TUBE WELDMENT - 30' OUTER LH	
	507-2-0136	FLAIL TUBE WELDMENT - 30' OUTER RH	
17	900-06015	HEX NUT - 3/4 NC	3
18	507-2-0125	INNER FLAIL TUBE WELDMENT - 27' & 30' LH	1
	507-2-0126	INNER FLAIL TUBE WELDMENT - 27' & 30' RH	1
19	500-3-0785	SHAFT - CENTER	1
20	900-11017	3/4 LOCK WASHER	3
21	900-01407	3/4-10 X 2-1/2 HEX BOLT ZP	3
22	900-39030	RETAINING RING 600 SERIES	4
23	500-3-0338	COUPLER	2
24	901-09126	O-RING, FLAIL COUPLER	2
25	507-2-0121	HANGER PLATE WELD	1
26	500-2-0598	BEARING ASSEMBLY, ROUND TEROG	1
27	900-06009	NUT HEX 1/2 UNC	1
28	505-3-0405	BUSHING, CUP KNIFE	
29	505-3-0004	CUP KNIFE - 7"	
	505-3-0006	CUP KNIFE - 9"	
	505-3-0005	CUP KNIFE - 11"	
30	900-06145	NUT, 5/8 WHIZ	
31	900-01792	BOLT, CARRIAGE 5/8-11 x 3.50	
32	900-06009	NUT, HEX, 1/2"	

3-POINT HITCH COMPONENTS

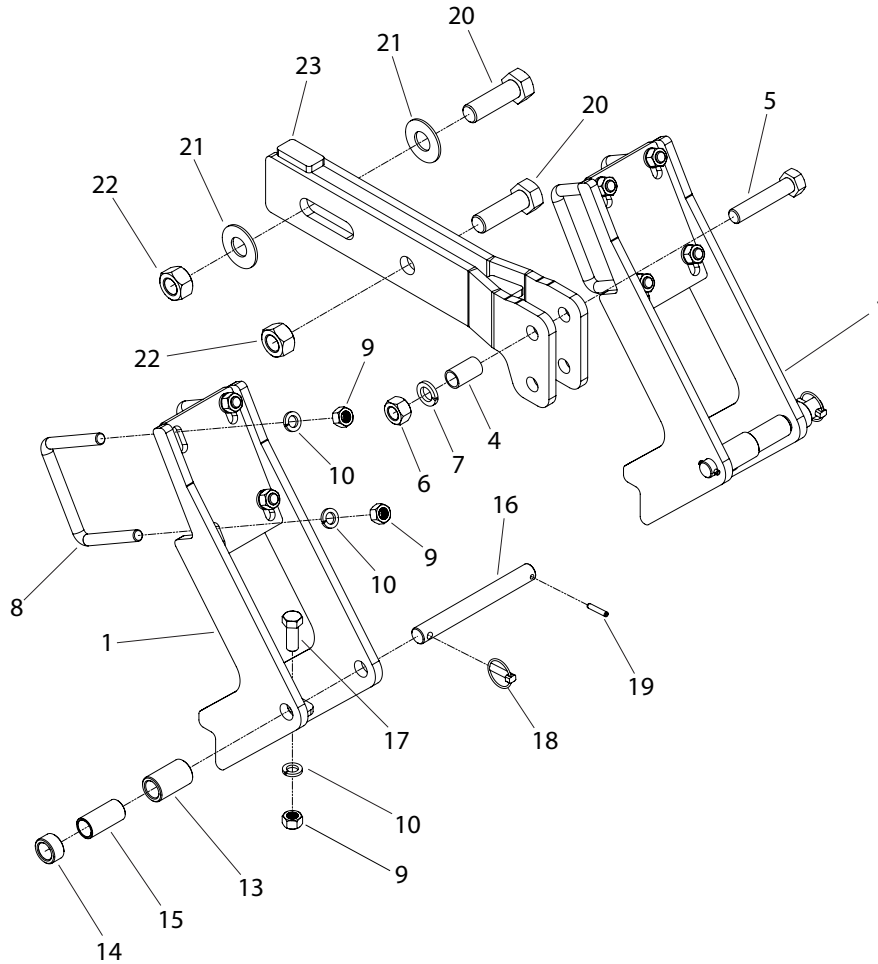

ITEM NO.	PART NUMBER	DESCRIPTION	QTY.
1	507-2-0192	LOWER 3-PT HITCH WELD	2
2	507-2-0303	UPPER MAST - TOP LINK	1
3	507-2-0020	UPPER MAST PLATE WELD	1
4	200-3-0151	MAST SPACER BUSHING	1
5	900-01531	BOLT, HEX HEAD 1 NC X 5, GR5 ZP	1
6	900-06019	NUT, HEX HEAD 1 NC	1
7	900-11021	WASHER, LOCK 1	1
8	200-3-0024	U-BOLT 3/4 X 6 X 5.5 X 1.5, GR5 ZP	4
9	900-06015	NUT, HEX HEAD 3/4 NC	12
10	900-11017	WASHER, LOCK 3/4	12
11	900-06518	NUT, TOP LOCK 1-1/4 NC	2
12	900-11042	WASHER, FLAT 1-1/4	2
13	200-3-0959	SPACER - LOWER 3 PT HITCH	2
14	200-3-0960	SPACER - LOWER 3 PT HITCH	2
15	200-3-0961	BUSHING - LOWER 3 PT	2
16	200-3-0962	PIN - LOWER 3PT	2
17	900-01403	BOLT, HEX HEAD 3/4 NC X 2, GR5 ZP	4
18	900-25012	KLICK PIN - 7/16 X 2	2
19	900-29204	PIN, SPRING, SLOTTED 5/16 X 1-5/8	2
20	900-01596	BOLT, HEX HEAD 1-1/4 NC X 4, GR5 ZP	2
	507-1-0002	CARTON - 3 PT HITCH	

PULL TYPE HITCH COMPONENTS

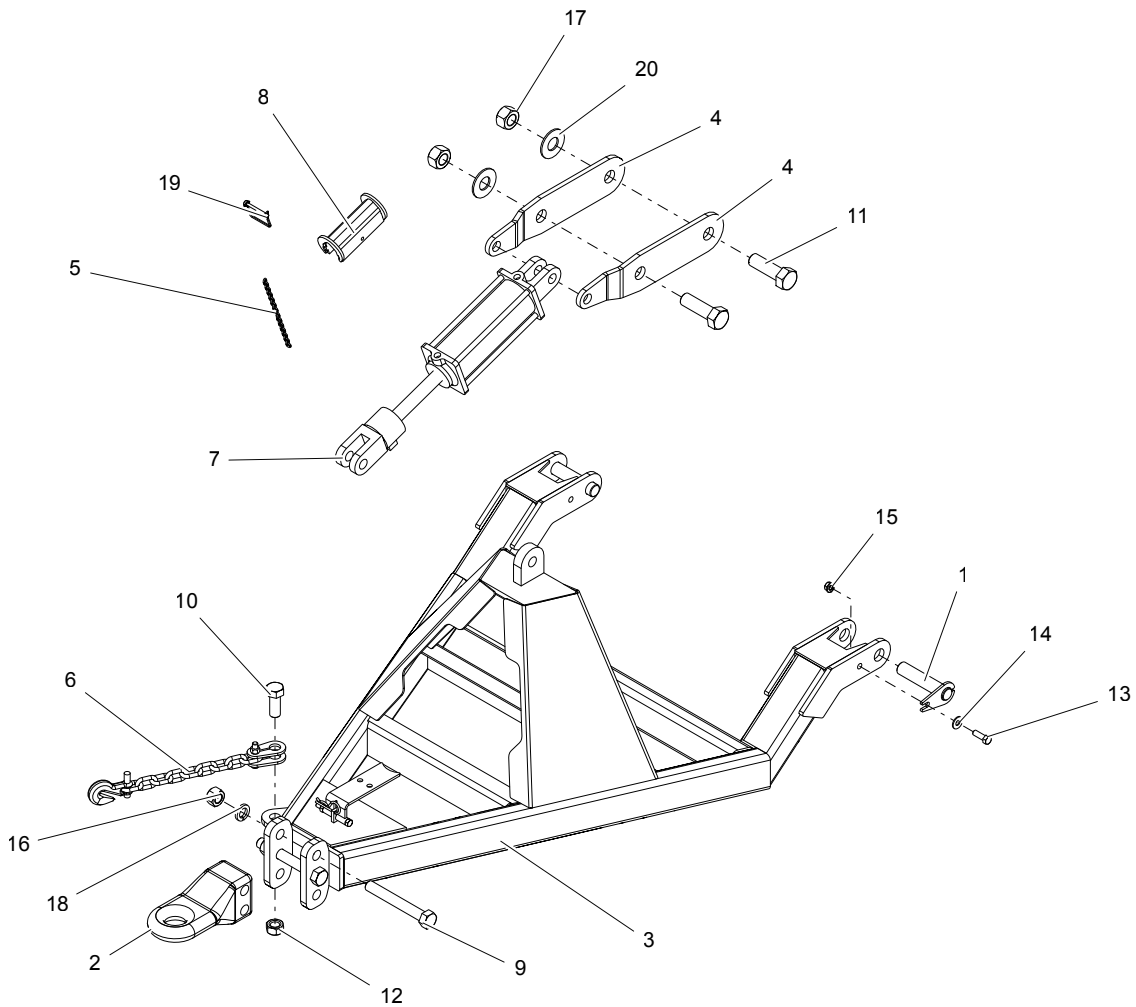

ITEM NO.	PART NUMBER	DESCRIPTION	QTY.
1	500-2-0684	WELD, PIN, 1-1/4	2
2	505-3-0831	HITCH, TONGUE COMP CAT3	1
3	507-2-0027	WELD, HITCH, PULL TYPE	1
4	507-3-0580	PLATE, CYL MOUNT - PULL TYPE	2
5	120-3-0472	RETAINING CHAIN	1
6	905-07123	CHAIN, SAFETY TOW - 21,000 LB	1
7	905-21400	HYD CYL - 3.5 x 8	1
8	700-2-0159	WELD, CYLINDER STOP, SHORT	1
9	900-01541	BOLT, HH, 1 NC x 7-1/2, GR5 ZP	2
10	900-01515	BOLT, HH, 1 NC x 2-1/2, GR5 ZP	1
11	900-01596	BOLT, HH, 1-1/4 NC x 4, GR5 ZP	2
12	900-06514	NUT, LOCK, TOP, 1 NC, ZP	1
13	900-01225	BOLT, HH, 1/2 NC x 1-1/2, GR5 ZP	2
14	900-11035	WASHER, FLAT, 1/2	2
15	900-06143	NUT, SPIRALOCK, 1/2 NC, GR5 ZP	2
16	900-06019	NUT, HH, 1 NC	2
17	900-06518	NUT, LOCK, TOP, 1-1/4 NC, ZP	2
18	900-11021	WASHER, LOCK, 1	2
19	900-42055	PIN, SNAPPER, 1/4 x 2-1/2	1
20	900-11042	WASHER, FLAT, 1-1/4	2
	507-1-0003	CARTON - PULL TYPE HITCH	

RIGID STRUT - DUAL (LARGE WHEELS)

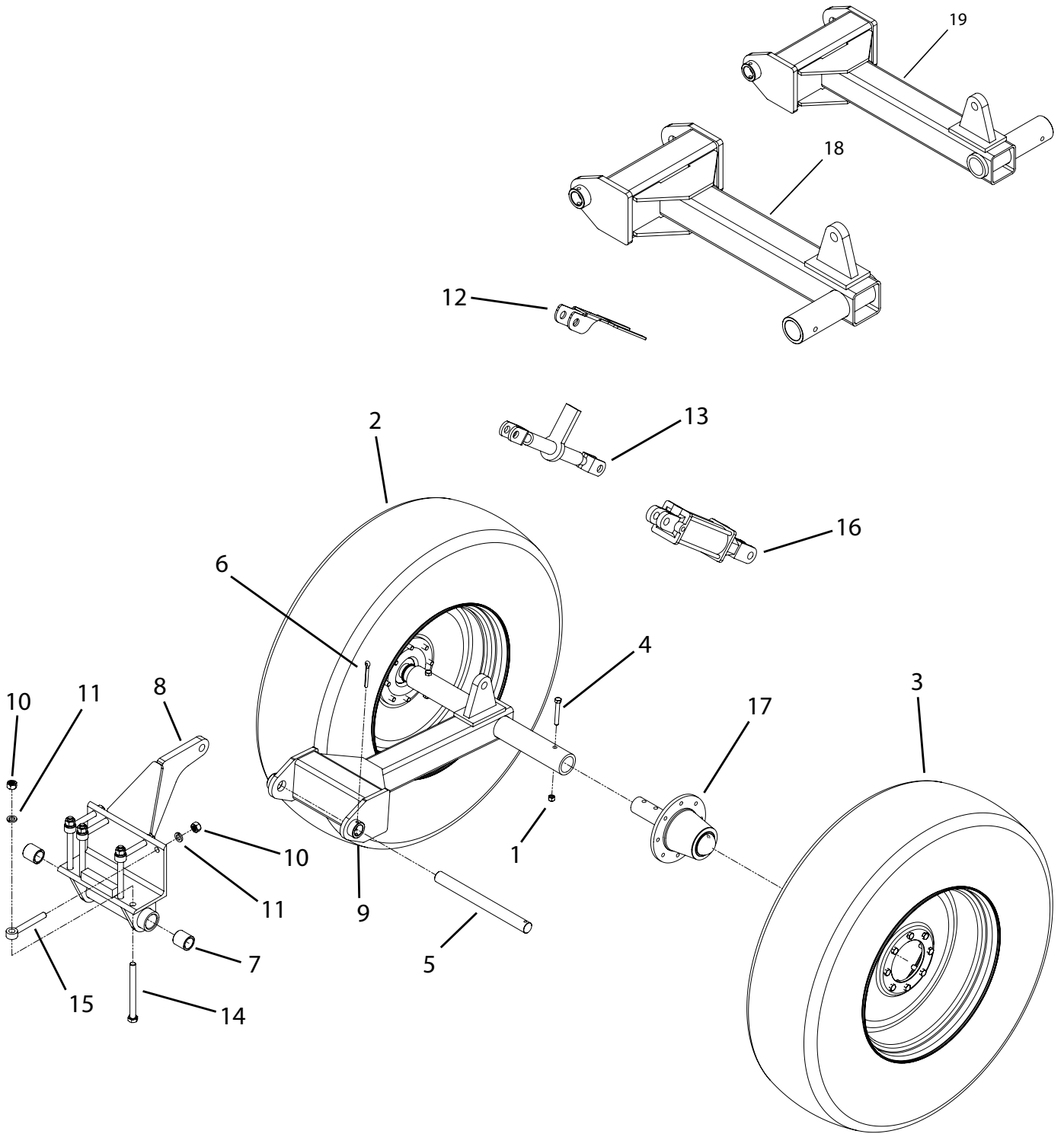

RIGID STRUT - DUAL (LARGE WHEELS)

ITEM NO.	PART NUMBER	DESCRIPTION	QTY.
1	900-06504	NUT, TOP LOCK 1/2 NC	2
2	700-2-0168	TIRE & RIM ASSEMBLY RH	1
3	700-2-0167	TIRE & RIM ASSEMBLY LH	1
	905-09127	- RIM, 24" X 10" X 8 BOLT	
	905-09130	- TIRE, 12.4 X 24 8 PLY R1	
4	900-01241	BOLT, HEX HEAD 1/2 NC X 3.5, GR5 ZP	2
5	500-3-1328	PIN, PIVOT	1
6	900-23084	PIN, COTTER 3/8 X 3-1/2	1
7	500-3-1151	BUSHING	2
8	500-2-1046	MOUNTING ANGLE WELDMENT- REAR STRUT	1
9	507-2-0182	REAR STRUT WELDMENT - DUAL 30" - 36"	1
	507-2-0181	REAR STRUT WELDMENT - DUAL 22" - 26"	
	507-2-0365	REAR STRUT WELDMENT - DUAL 38" - 40"	
10	900-06015	NUT, HEX HEAD 3/4 NC	8
11	900-11017	WASHER, LOCK 3/4	8
12	500-3-2202	RACHET JACK SUPPORT BRACKET	1
13	905-23014	RATCHET JACK HEAVY DUTY	1
14	900-01437	BOLT, HEX HEAD 3/4 NC X 8-1/2, GR5 ZP	4
15	900-03463	BOLT, EYE 3/4 NC, GR5 ZP	4
16	905-21398	CYLINDER, 3-3/4 X 8R BLACK	1
	905-21405	- SEAL KIT, 3-3/4	
	905-21290	CYLINDER, 3-1/2 X 8R BLACK	
	905-21371	- SEAL KIT, 3-1/2	
17	500-2-0165	HUB & SPINDLE ASSEMBLY	1
18	507-2-0187	REAR STRUT WELD - SINGLE RH	
19	507-2-0188	REAR STRUT WELD - SINGLE LH	

RIGID STRUT - DUAL (MEDIUM WHEELS)

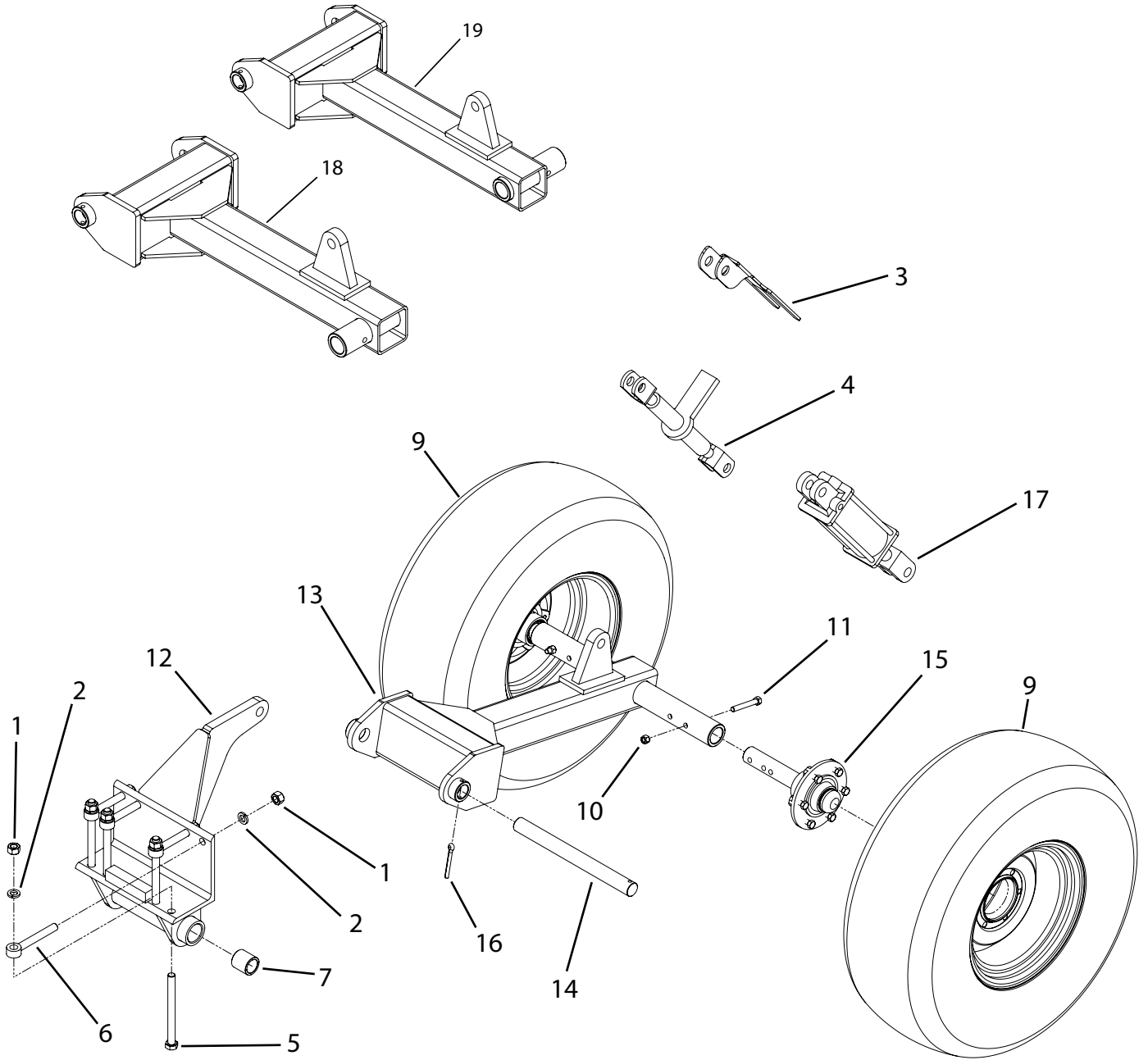

RIGID STRUT - DUAL (MEDIUM WHEELS)

ITEM NO.	PART NUMBER	DESCRIPTION	QTY.
1	900-06015	NUT, HEX HEAD 3/4 NC	8
2	900-11017	WASHER, LOCK 3/4	8
3	500-3-2202	RACHET JACK SUPPORT BRACKET	1
4	905-23014	RATCHET JACK HEAVY DUTY	1
5	900-01437	BOLT, HEX HEAD 3/4 NC X 8-1/2, GR5 ZP	4
6	900-03463	BOLT, EYE 3/4 NC, GR5 ZP	4
7	500-3-1151	BUSHING	2
9	905-09181	TIRE & RIM ASSEMBLY	1
	905-09179	- RIM, 16" X 10" X 6 BOLT	
	905-19180	- TIRE, 12.5 X 16	
10	900-06504	NUT, TOP LOCK 1/2 NC	2
11	900-01241	BOLT, HEX HEAD 1/2 NC X 3-1/2, GR5 ZP	2
12	500-2-1046	MOUNTING ANGLE WELDMENT - REAR STRUT	1
13	507-2-0083	REAR STRUT WELD - DUAL 22" - 26"	1
	507-2-0093	REAR STRUT WELD - DUAL 30" - 36"	
	507-2-0366	REAR STRUT WELD - DUAL 38" - 40"	
14	500-3-1328	PIN, PIVOT	1
15	200-2-2344	HUB & SPINDLE ASSEMBLY	1
16	900-23084	PIN, COTTER 3/8 X 3-1/2	1
17	905-21398	CYLINDER, 3-3/4 X 8R BLACK	1
	905-21405	- SEAL KIT, 3-3/4	
	905-21290	CYLINDER, 3-1/2 X 8R BLACK	1
	905-21371	- SEAL KIT, 3-1/2	
18	507-2-0184	REAR STRUT WELD - SINGLE RH	
19	507-2-0186	REAR STRUT WELD - SINGLE LH	

LIGHT KIT COMPONENTS

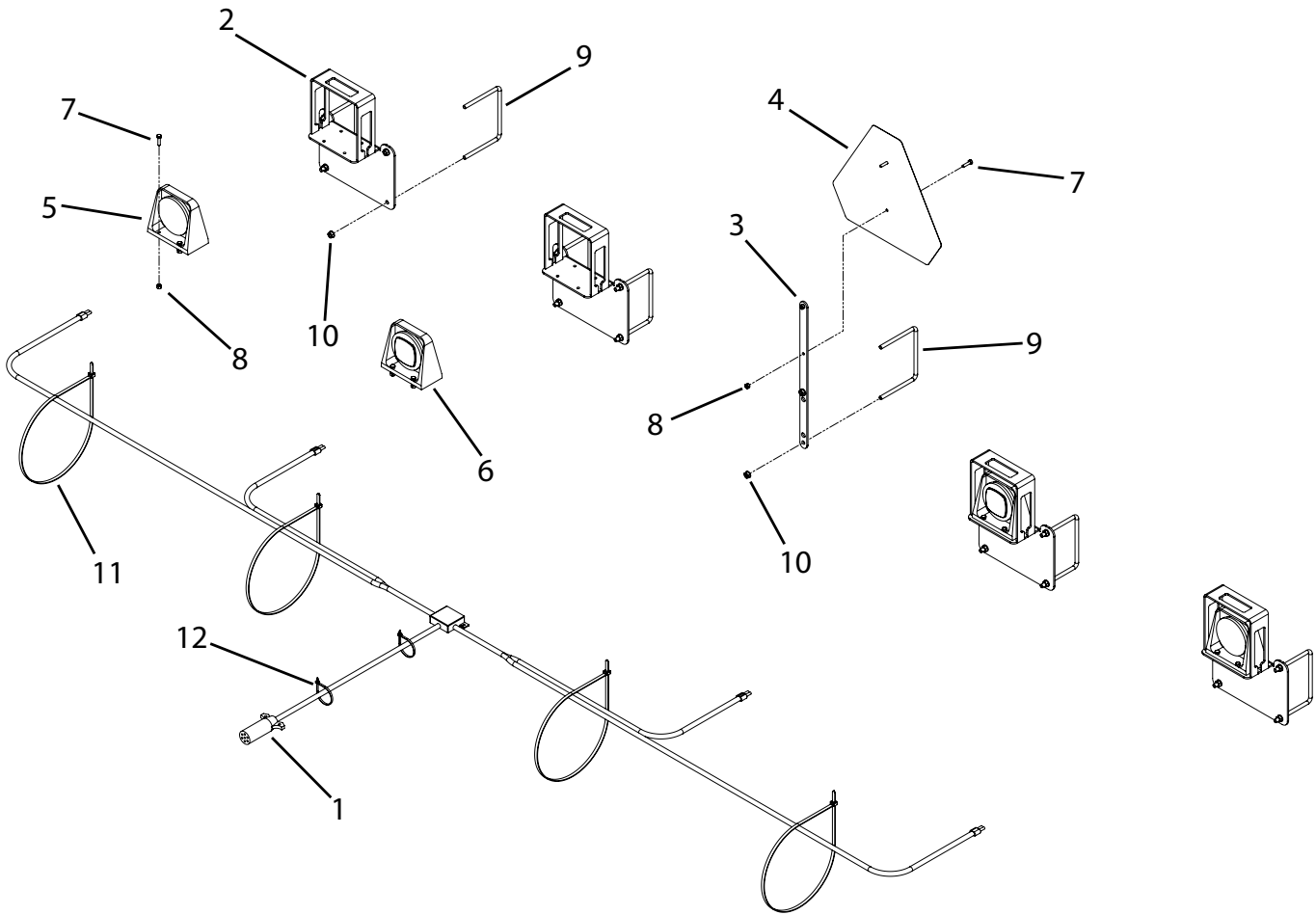

ITEM NO.	PART NUMBER	DESCRIPTION	QTY.
1	507-3-0218	WIRE HARNESS - (12' - 18')	1
	507-3-0237	WIRE HARNESS - (20' - 22')	
	507-3-0238	WIRE HARNESS - (25' - 30')	
2	507-2-0108	LIGHT BRACKET	4
3	500-3-2091	SMV MOUNT	1
4	500-3-1696	SMV SIGN	1
5	904-01154	AMBER LAMP	2
6	904-01155	RED LAMP	2
7	900-01009	BOLT, HEX HEAD 1/4-20 X 1	18
8	900-06496	NUT, TOP LOCK 1/4-20	18
9	900-06139	U-BOLT, 3/8 X 6 X 5	9
10	900-06139	NUT, SERR FLANGE 3/8	18
11	905-07128	CABLE TIE, PLASTIC 36" LONG	4
12	905-07127	CABLE TIE, PLASTIC 7.5" LONG	2

CENTER DRIVE GEARBOX

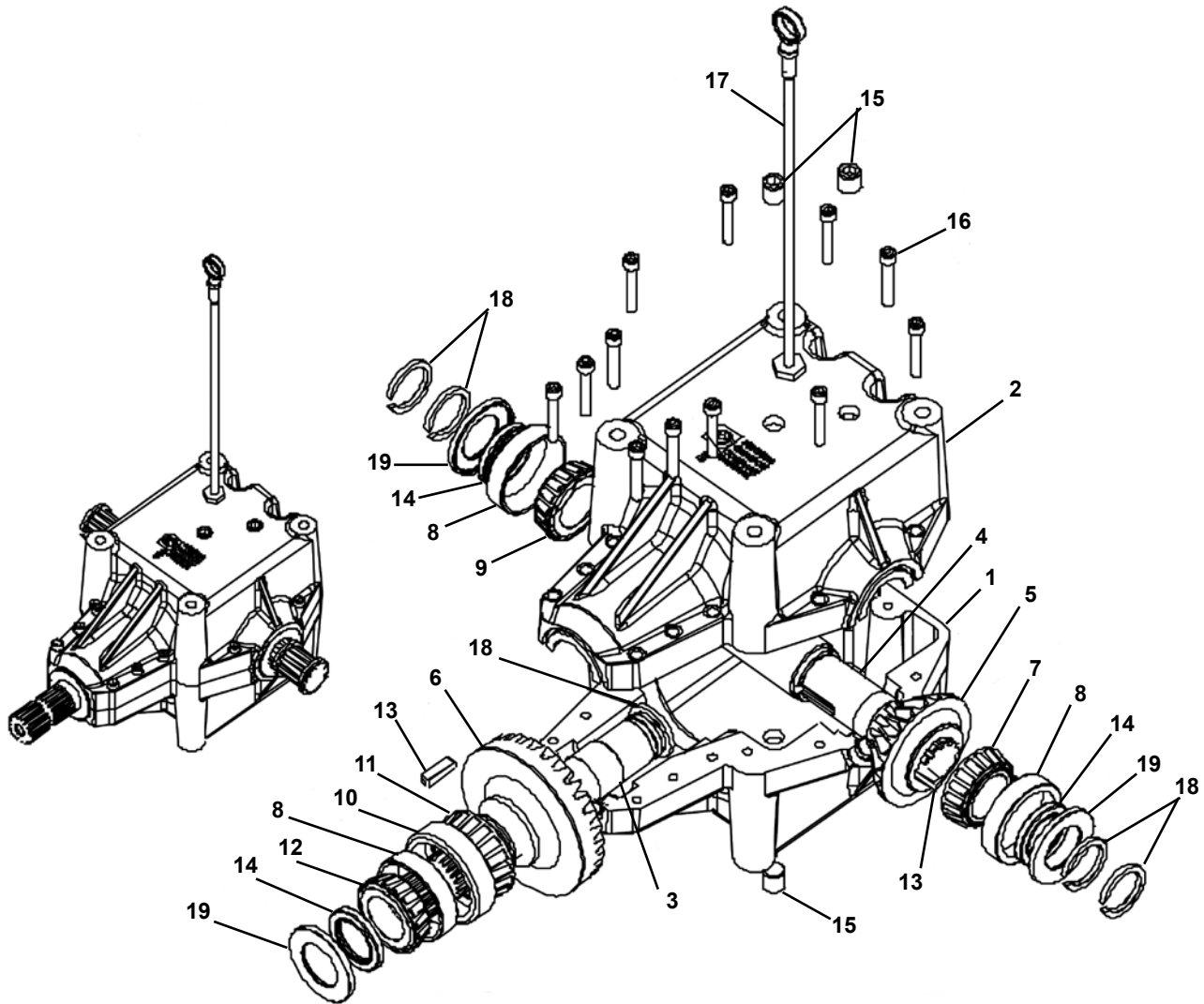

ITEM NO.	PART NUMBER	DESCRIPTION	QTY.
1	903-18222	HOUSING, SEAL GUARD	1
2	903-18223	CASTING, MACH R800 THRU	1
3	903-15567	SHAFT, STUB R600 KEYED 20T	1
4	903-15568	SHAFT, CROSS R600 KEYED 2X 10T	1
5	903-15321	GEAR R6 1.5 .375 KEYED 20T	1
6	903-15320	GEAR R6 1.5 .375 KEYED 30T	1
7	901-01150	BEARING, CONE 1.750 VN-25581	1
8	901-01152	BEARING, CUP 3.2650 VN-25520	3
9	901-01328	BEARING, CONE 25580	1
10	901-01153	BEARING, CUP 3.6718 VN-3720	1
11	901-09230	BEARING, CONE TMKN #3777	1
12	901-09231	BEARING, CONE TMKN #25592	1
13	903-15374	KEY, 3/8 X 3/8, 1.435	2
14	901-09125	SEAL, 1.750-2.437-.312 (R) TC	3
15	905-03078	PLUG, 1/2-14NPT SCHD W/3M	4
16	900-03033	BOLT, 3/8-16 X 2.25 SHCS	12
17	903-18225	DIPSTICK, R800 1/2-14NPT	1
18	900-39030	RETAINING RING, EXT 1.750 SHFT	5
19	901-09233	GUARD, SEAL (OD3.00 ID1.745)	3
	903-15566	COMPLETE GEARBOX	

HUB & SPINDLE ASSEMBLY COMPONENTS

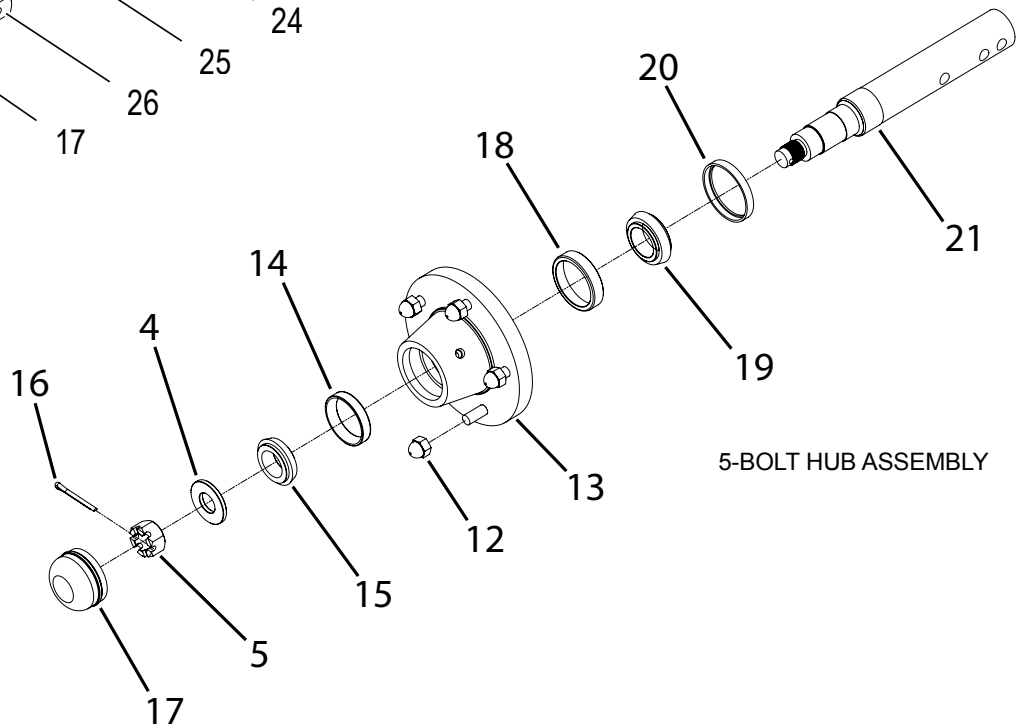
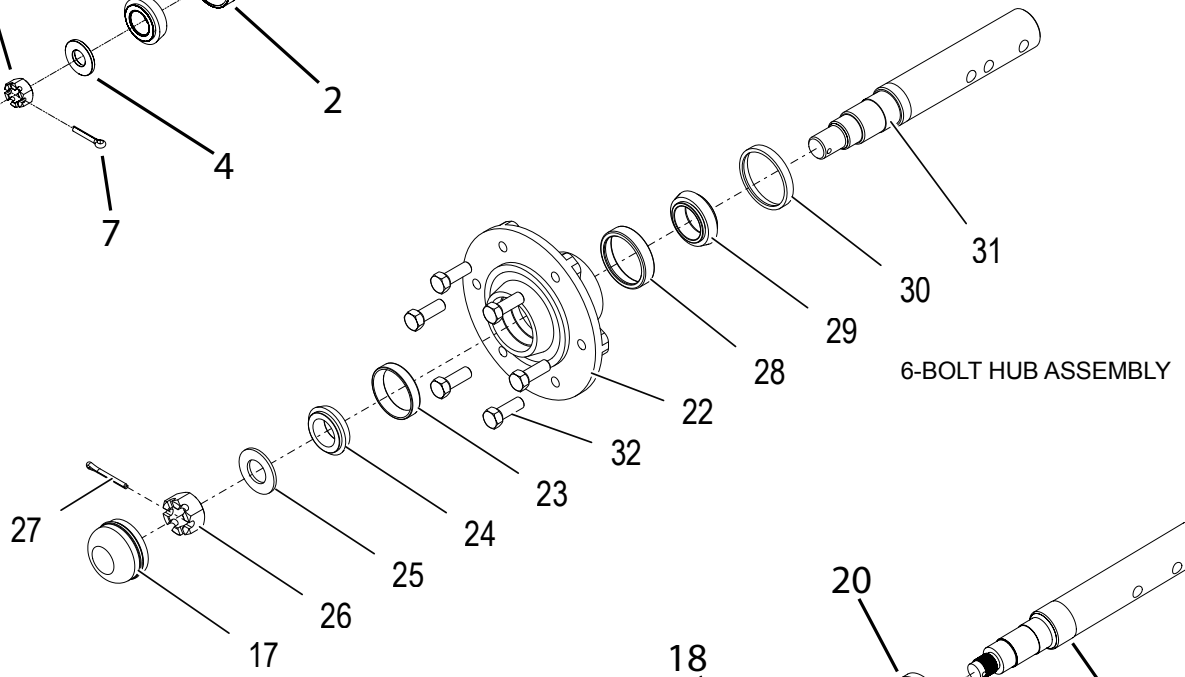
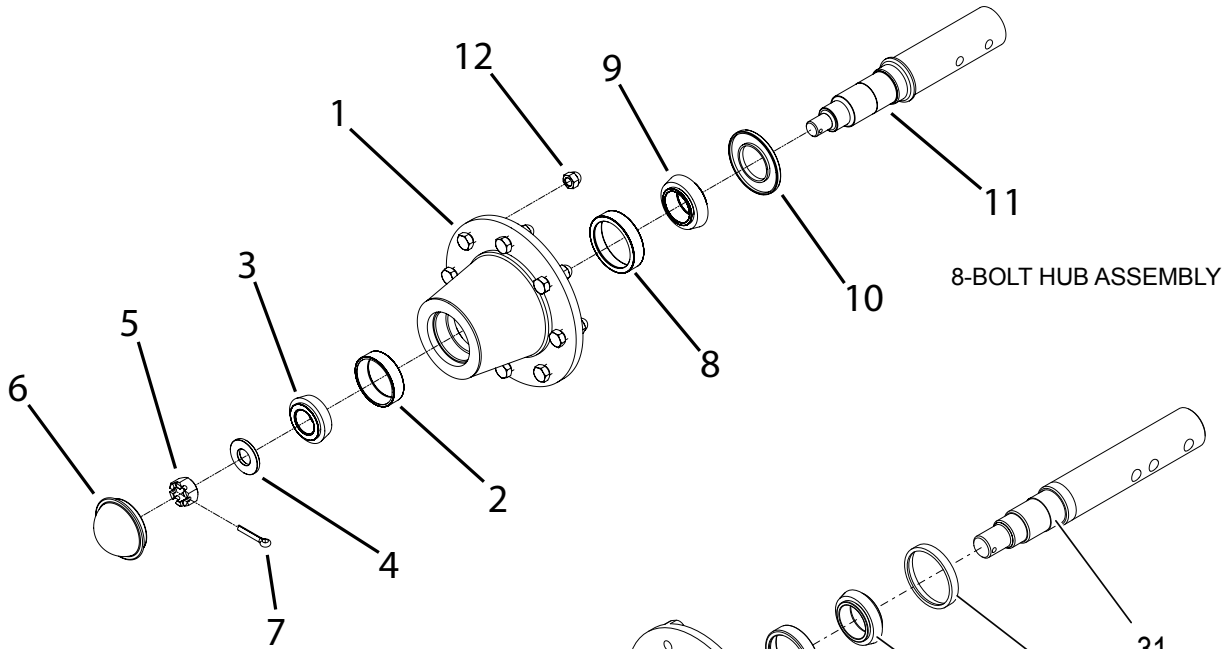

HUB & SPINDLE ASSEMBLY COMPONENTS

ITEM NO.	PART NUMBER	DESCRIPTION	QTY.
1	905-09136	HUB W/ CUPS (8-BOLT)	1
2	901-01324	BEARING CUP	1
3	901-01326	BEARING CONE	1
4	905-09067	WASHER, 7/8 SAE	1
5	900-06060	NUT, HEX HEAD, SLOTTED 7/8 NF	1
6	905-09135	HUB CAP	1
7	900-23064	PIN, COTTER 1/2 X 2	1
8	901-01152	BEARING CUP	1
9	901-01325	BEARING CONE	1
10	901-09215	SEAL	1
11	700-3-0143	SPINDLE	1
12	905-09011	NUT, HEX HEAD, WHEEL 1/2 NF	8
13	905-09003	HUB W/ CUPTS (5-BOLT)	1
14	901-01016	BEARING CUP	1
15	901-01015	BEARING CONE	1
16	900-23043	PIN, COTTER 3/16 X 1-1/2	1
17	905-09009	CAP, DUST	1
18	901-01022	BEARING CUP	1
19	901-01023	BEARING CONE	1
20	901-09002	SEAL, OIL TRANSCOM	1
21	500-3-0136	SPINDLE	1
22	905-09176	HUB W/ CUPS (6-BOLT)	1
23	901-01016	BEARING CUP	1
24	901-01015	BEARING CONE	1
25	905-09068	WASHER, 1 SAE	1
26	900-06062	NUT, SLOTTED, 1 NF	1
27	900-23045	PIN, COTTER, 3/16 x 2	1
28	901-01024	BEARING CUP	1
29	901-01025	BEARING CONE	1
30	901-09002	SEAL, BORE	1
31	200-3-4440	SPINDLE	1
32	905-09010	BOLT, WHEEL, 1/2 NF x 1-1/16	6

2-POINT & 3-POINT PTO COMPONENTS

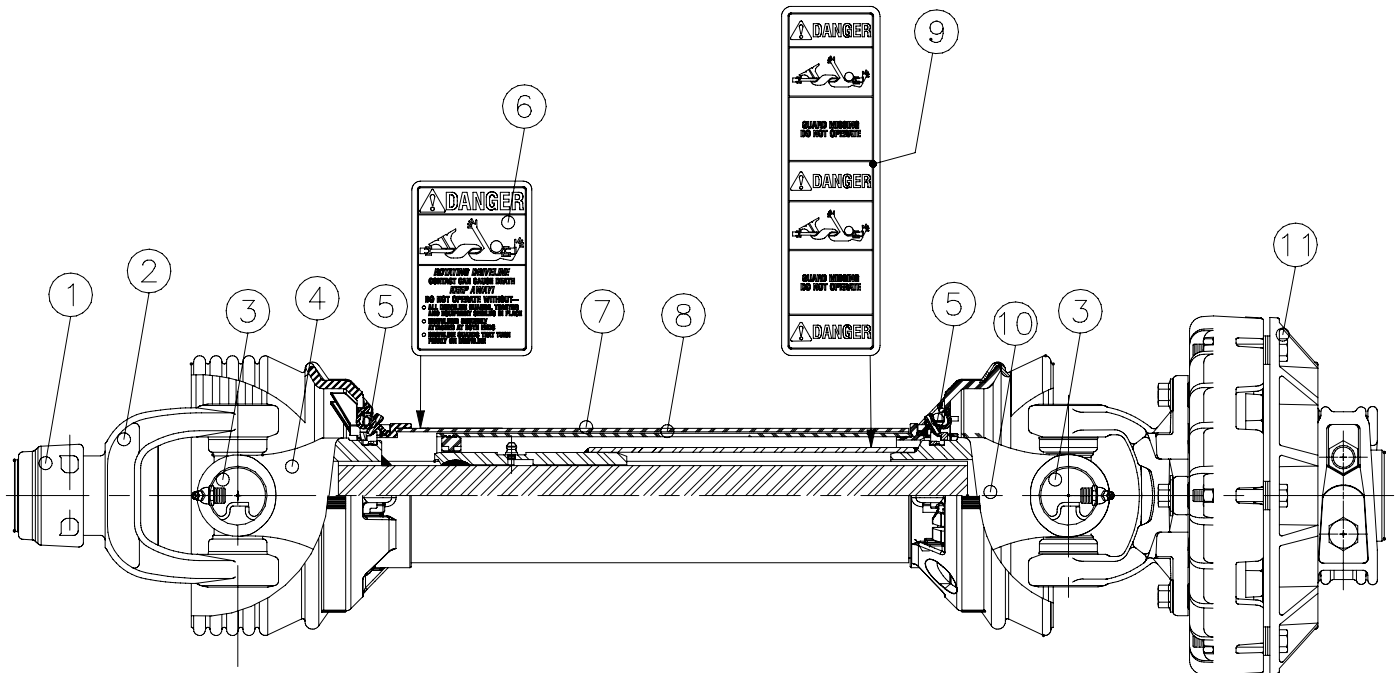

ITEM NO.	PART NUMBER	DESCRIPTION	QTY.
1	903-18106	SSL / AUTO-LOK REPAIR KIT, 1-3/8"	1
	903-17772	SSL / AUTO-LOK REPAIR KIT, 1-3/4"	1
2	903-18403	SAFETY SLIDE LOCK YOKE ASSEMBLY, 1-3/8"	1
	903-17418	SAFETY SLIDE LOCK YOKE ASSEMBLY, 1-3/4"	1
3	903-17239	55E CROSS & BEARING KIT	2
4	903-18404	YOKE & SHAFT (1.69-20 SPLINE)	
5	903-18248	GUARD REPAIR KIT (NOT SHOWN)	2
6	903-17455	SAFETY SIGN	1
7	903-18319	OUTER GUARD	1
8	903-18320	INNER GUARD	1
9	903-17456	SAFETY SIGN	1
10	903-18321	YOKE, TUBE, & SLIP SLEEVE	1
11	903-18303	OVER RUNNING FRICTION CLUTCH ASSEMBLY	1
	903-18313	SLIP CLUTCH PTO, 1-3/8", COMPLETE	
	903-18335	SLIP CLUTCH PTO, 1-3/4", COMPLETE	

PULL-TYPE PTO COMPONENTS

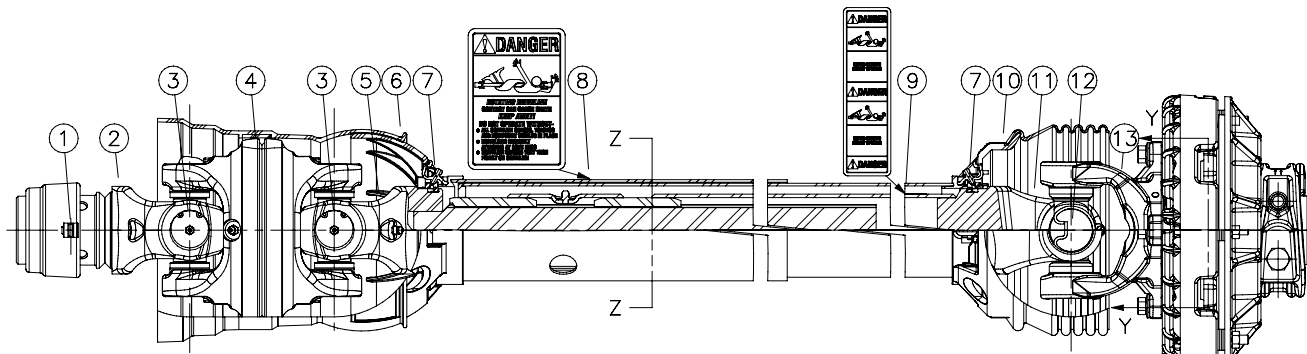

ITEM NO.	PART NUMBER	DESCRIPTION	QTY.
1	903-18106	SSL / AUTO-LOK REPAIR KIT 1-3/8"	1
	903-17772	SSL / AUTO-LOK REPAIR KIT 1-3/4"	1
2	903-18334	WWCV AUTO-LOK YOKE ASSEMBLY 1-3/8"	1
	903-18327	WWCV AUTO-LOK YOKE ASSEMBLY 1-3/4"	1
3	903-18328	AB8/AW24EBL CROSS & BEARING KIT	2
4	903-18329	WWCV CENTER HOUSING	1
5	903-18330	WWCV YOKE & SHAFT (1.69-20 SPLINE)	1
6	903-18389	OUTER GUARD	1
7	903-18248	GUARD REPAIR KIT	2
8	903-17455	SAFETY SIGN	1
9	903-17456	SAFETY SIGN	1
10	903-18390	INNER GUARD	1
11	903-18391	YOKE, TUBE, & SLIP SLEEVE	1
12	903-17239	55E CROSS & BEARING KIT	1
13	903-18303	OVER RUNNING FRICTION CLUTCH ASSEMBLY	1
	903-18283	GUARD SET	1
	903-18315	CV SLIP CLUTCH PTO, 1-3/8", COMPLETE	
	903-18314	CV SLIP CLUTCH PTO, 1-3/4", COMPLETE	

TORQ MASTER CLUTCH COMPONENTS

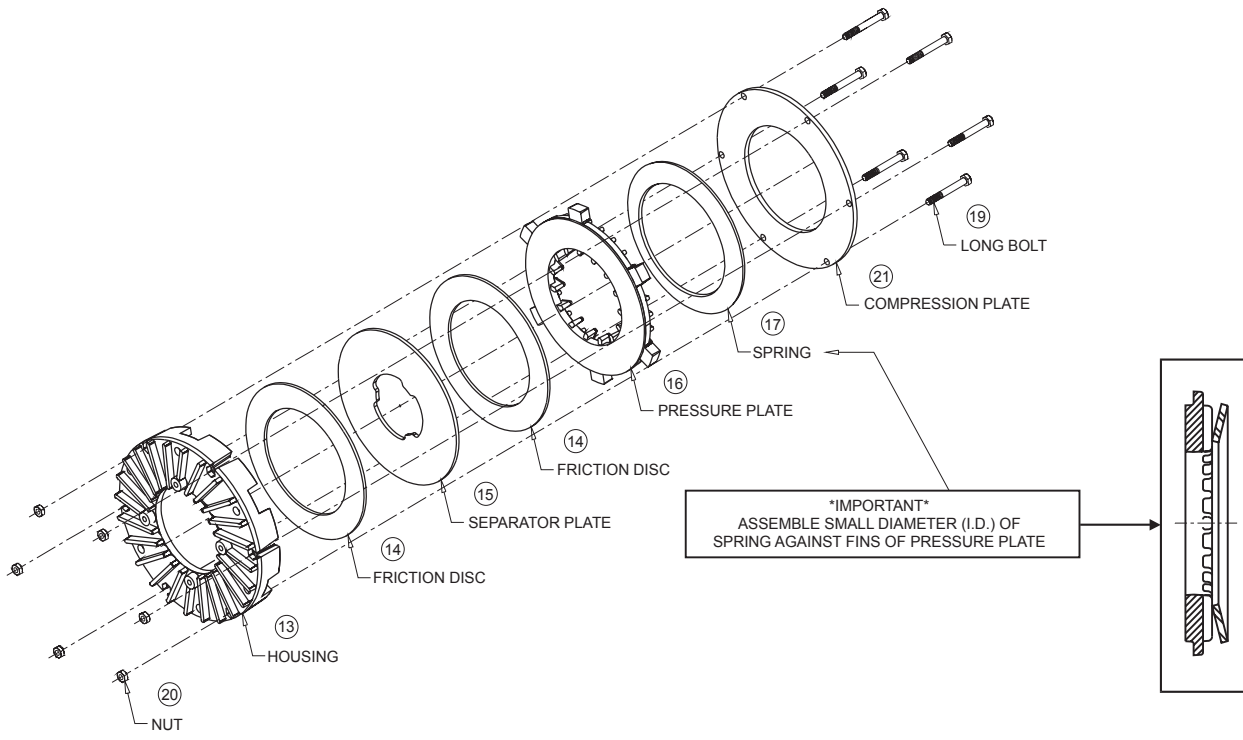
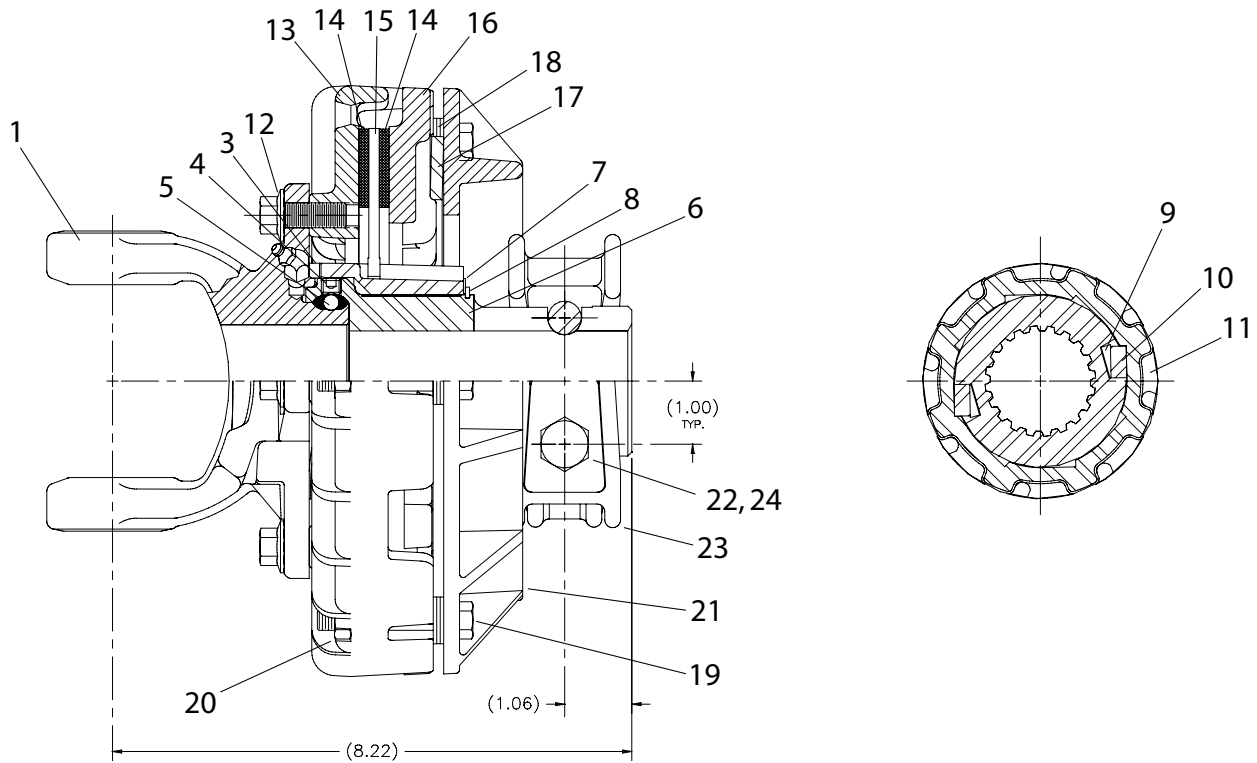

TORQ MASTER CLUTCH COMPONENTS



ITEM NO.	PART NUMBER	DESCRIPTION	QTY.
1	903-18191	YOKE	1
2	903-18226	OVERRUNNING REPAIR KIT, (2, 6, 7, 8, 9) {Not Shown}	
3	903-18165	WAVE SPRING	1
4	903-18154	SET SCREW, .315-18 X .25 LG	1
5	903-17541	BALL, Ø.250, GRADE 5	31
6	903-18232	OVERRUNNING INNER HUB	1
7	903-18167	WASHER	1
8	903-18168	RETAINING RING	1
9	903-18170	LEAF SPRING	2
10	903-18171	OVERRUNNING KEY	2
11	903-18169	OVERRUNNING HUB	1
12	900-03055	BOLT, M10 X 1.50 X 25mm LG, CLASS 10.9	4
13	903-18227	HOUSING	1
14	903-18175	FRICTION DISC	2
15	903-18174	SEPARATOR PLATE	1
16	903-18228	PRESSURE PLATE	1
17	903-18195	SPRING	1
18	900-11236	WASHER, M8 NARROW	24
19	900-03053	BOLT, M8 X 1.25 X .60 LG, CLASS 10.9	6
20	900-06548	NUT, M8 X 1.25	6
21	903-18229	COMPRESSION PLATE	1
22	903-03098	BOLT, .500-13 X 3.50 LG., GRADE 8	2
23	903-18340	HUB CLAMP	2
24	900-06549	NUT, LOCK .500-13, GRADE G	2
	903-18233	CLAMP - INCLUDES: #22 - #24	
	903-18234	YOKE & HUB ASM. - INCLUDES: #1 - #11	
	903-18235	FRICTION PACK - INCLUDES: #12 - #21	
	903-18303	FRICTION OVERRUNNING CLUTCH ASSEMBLY - INCLUDES: 903-18336, 903-18337, 903-18338	

BOLT TORQUE CHART

SAE Series Torque Chart

Always tighten hardware to these values unless a different torque value or tightening procedure is listed for a specific application. Fasteners must always be replaced with the same grade as specified in the manual parts list.

Make sure fastener threads are clean and you properly start thread engagement.

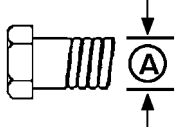
SAE Bolt Head Identification		 SAE Grade 2 (No Dashes)		 SAE Grade 5 (3 Radial Dashes)		 SAE Grade 8 (6 Radial Dashes)	
A Diameter (Inches)	Wrench Size	MARKING ON HEAD					
		SAE 2		SAE 5		SAE 8	
		ft./lb.	(Nm)	ft./lb.	(Nm)	ft./lb.	(Nm)
1/4"	7/16"	6	(8)	10	(13)	14	(18)
5/16"	1/2"	12	(17)	19	(26)	27	(37)
3/8"	9/16"	23	(31)	35	(47)	49	(67)
7/16"	5/8"	36	(48)	55	(75)	78	(106)
1/2"	3/4"	55	(75)	85	(115)	120	(163)
9/16"	13/16"	78	(106)	121	(164)	171	(232)
5/8"	15/16"	110	(149)	170	(230)	240	(325)
3/4"	1-1/8"	192	(261)	297	(403)	420	(569)
7/8"	1-5/16"	306	(416)	474	(642)	669	(907)
1"	1-1/2"	350	(475)	680	(925)	1020	(1383)
1-1/8"	1-11/16"	450	(610)	885	(1200)		Bolt Diameter
1-1/4"	1-7/8"	600	(815)	1255	(1700)		
1-3/8"	2-1/16"	675	(915)	1620	(2200)		
1-1/2"	2-1/4"	920	(1250)	2200	(2900)		

Metric Series Torque Chart

Use only metric tools on metric hardware. Always tighten hardware to these values unless a different torque value or tightening procedure is listed for a specific application. Fasteners must always be replaced with the same grade.

Make sure fastener threads are clean and you properly start thread engagement.

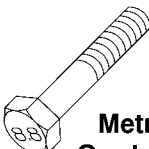
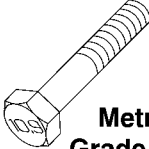
A Diameter & Thread Pitch (Millimeters)	Wrench Size	COARSE THREAD				FINE THREAD				A Diameter & Thread Pitch (Millimeters)	Metric Bolt Head Identification
		MARKING ON HEAD				MARKING ON HEAD					
		Metric 8.8		Metric 10.9		Metric 8.8		Metric 10.9			
		Nm	ft./lb.	Nm	ft./lb.	Nm	ft./lb.	Nm	ft./lb.		
6x1.0	10 mm	8	6	11	8	8	6	11	8	6x1.0	 Metric Grade 8.8  Metric Grade 10.9
8x1.25	13 mm	20	15	27	20	21	16	29	22	8x1.0	
10x1.5	16 mm	39	29	54	40	41	30	57	42	10x1.25	
12x1.75	18 mm	68	50	94	70	75	55	103	76	12x1.25	
14x2.0	21 mm	109	80	151	111	118	87	163	120	14x1.5	
16x2.0	24 mm	169	125	234	173	181	133	250	184	16x1.5	
18x2.5	27 mm	234	172	323	239	263	194	363	268	18x1.5	
20 x 2.5	30 mm	330	244	457	337	367	270	507	374	20x1.5	
22 x 2.5	34 mm	451	332	623	460	495	365	684	505	22 x 1.5	
24 x 3.0	36 mm	571	421	790	583	623	459	861	635	24 x 2.0	
30 x 3.0	46 mm	1175	867	1626	1199	1258	928	1740	1283	30 x 2.0	

Typical Washer Installations

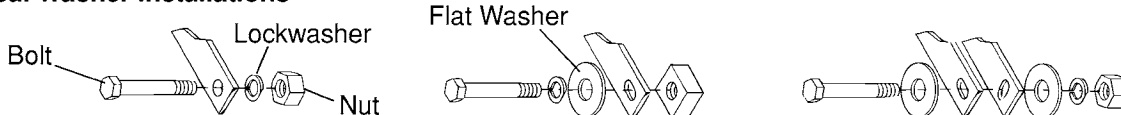

8/9/00

ABBREVIATIONS

AG	Agriculture	N.....	Newton
ASAE	American Society of Agricultural Engineers	NC.....	National Course
ATF.....	Automatic Transmission Fluid	NF.....	National Fine
BSPP.....	British Standard Pipe Parallel	NPSM.....	National Pipe Straight Mechanical
BSPTM.....	British Standard Pipe Tapered Male	NPT	National Pipe Tapered
CV	Constant Velocity	NPT SWF.....	National Pipe Tapered Swivel Female
CCW	Counter-Clockwise	Nm.....	Newton Meter
CW.....	Clockwise	OSHA...	Occupational Safety and Health Administration
DIA.....	Diameter	P	Pitch
EP.....	Extreme Pressure	PBY	Power Beyond
F	Female	psi.....	Pounds per Square Inch
FB.....	Female O-Ring Boss	PTO.....	Power Take Off
FJ	Female Boss	QD	Quick Disconnect
FJX.....	Female Swivel JIC	RH.....	Right Hand
FP.....	Female Pipe	ROPS.....	Roll Over Protection Structure
ft./lb.....	Foot Pound	RPM	Revolutions Per Minute
GA.....	Gauge	RT.....	Right
GR (5, etc.)	Grade (5, etc.)	SAE	Society of Automotive Engineers
HHCS.....	Hex Head Cap Screw	SMV	Slow Moving Vehicle
HH.....	Hex Head	UNC	Unified Coarse
HT.....	Heat Treated	UNF.....	Unified Fine
in.....	Inch	UNS.....	Unified Special
JIC.....	Joint Industry Council 37° Flare	ZP.....	Zinc Plate
kg.....	Kilogram		
km/h	Kilometers Per Hour		
lb.....	Pound		
LH.....	Left Hand		
LT.....	Left		
in.....	Inches		
m	Meter		
mm.....	Millimeter		
M	Male		
MB.....	Male O-Ring Boss		
MJ.....	Male JIC		
MJX.....	Male Swivel JIC		
MP.....	Male Pipe		
MPa.....	Mega Pascal		
MPH.....	Miles Per Hour		

INDEX

ADDITIONAL EQUIPMENT	27	OPERATION	13
Center Divider	27	Attaching to the Tractor	18
End Guards & Skids	27	3 - Point & 2 - Point	18
Front Shield Flap	27	Hydraulics	19
ASSEMBLY	45	PTO Driveline	19
3 - Point	46	Pull - Type	18
Manual Storage Tube	47	Raising Stands	19
Pull - Type	47	Breaking-In	16
Wheel Assembly	46	Choosing the Correct Equipment	15
Safety Lights (End Tow)	47	3 - Point	16
Safety Lights (Non - End Tow)	48	Drawbar Clearance	16
GENERAL		Horsepower	15
Abbreviations	72	Load Sensing Hydraulics	16
Bolt Torque Chart	71	Tractor Weight	15
Check Lists	10, 15	Pre-Operation Check List	15
General Information	1	Principal Components	14
Introduction	Inside Front Cover	PTO Driveline Dimensions	18
Product Warranty	Inside Back Cover	Removing from the Tractor	19
Replacement Part Warranty	74	Tractor Hp vs Unit Width	15
Table of Contents	1	PARTS INDEX	51
Contour Flail Patterns	42	SERVICE & MAINTENANCE	29
FIELD OPERATION	21	Acceptable Oil Leakage	34
Flail Types	24	Change Gearbox Oil	34
Ground Speed	26	Greasing	29
Hazard Area	26	Lubricants	29
Preparing for Operation	22	Lubrication Schedule	30
Flail Height	22	Lubrication Service Record	33
Setting Flail Height	24	Replacing Flails	36
Setting Operating Height	23	Replacing Rubber Shield Flaps	36
3-Point Type	23	Replacing Stub Shaft	38
Pull Type	23	Servicing Modular Friction Clutch	38
Setting Outer Trailing Wheels	25	Servicing Rotors	37
Speed vs Weight Ratio	22	Setting Ratchets	35
Starting the Tractor	25	Trouble Shooting	37
Stopping the Tractor	25	Wheel Spacing	35
Transporting	22	STORAGE	28
Turning	26	TROUBLE SHOOTING	41
3 - Point	26		
Pull Type	26		
Starting the Tractor	25		

WARRANTY

Please Enter Information Below and Save For Future Reference.

Date Purchased: _____ From (Dealer): _____

Model Number: _____ Serial Number: _____

ALLOWAY STANDARD, d/b/a ALLOWAY, warrants this product to be free from defect in material and workmanship for TWELVE (12) MONTHS COMMENCING ON THE DATE OF DELIVERY OF THE PRODUCT TO THE ORIGINAL PURCHASER.

Under no circumstances will this Warranty apply in the event that the product, in the good faith opinion of ALLOWAY, has been subjected to improper operation, improper maintenance, misuse, or an accident. This Warranty does not apply in the event that the product has been materially modified or repaired by someone other than ALLOWAY, a ALLOWAY authorized dealer or distributor, and/or a ALLOWAY authorized service center; This Warranty does not cover normal wear or tear, or normal maintenance items. This Warranty also does not cover repairs made with parts other than those obtainable through ALLOWAY.

This Warranty is extended solely to the original purchaser of the product. Should the original purchaser sell or otherwise transfer this product to a third party, this Warranty does not transfer to the third party purchaser in any way. There are no third party beneficiaries of this Warranty.

ALLOWAY makes no warranty, express or implied, with respect to tires or other parts or accessories not manufactured by ALLOWAY. Their respective manufacturers, if any, provide warranties for these items, separately. ALLOWAY'S' obligation under this Warranty is limited to, at ALLOWAYS' option, the repair or replacement, free of charge, of the product if ALLOWAY, in its sole discretion, deems it to be defective or in noncompliance with this Warranty. The product must be returned to ALLOWAY with proof of purchase within thirty (30) days after such defect or noncompliance is discovered or should have been discovered, routed through the dealer and distributor from whom the purchase was made, transportation charges prepaid. ALLOWAY shall complete such repair or replacement within a reasonable time after ALLOWAY receives the product. THERE ARE NO OTHER REMEDIES UNDER THIS WARRANTY. THE REMEDY OF REPAIR OR REPLACEMENT IS THE SOLE AND EXCLUSIVE REMEDY UNDER THIS WARRANTY.

THERE ARE NO WARRANTIES, WHICH EXTEND BEYOND THE DESCRIPTION ON THE FACE OF THIS WARRANTY. ALLOWAY MAKES NO OTHER WARRANTY, EXPRESS OR IMPLIED, AND ALLOWAY SPECIFICALLY DISCLAIMS ANY IMPLIED WARRANTY OF MERCHANTABILITY AND/OR ANY IMPLIED WARRANTY OF FITNESS FOR A PARTICULAR PURPOSE.

ALLOWAY shall not be liable for any incidental or consequential losses, damages or expenses, arising directly or indirectly from the product, whether such claim is based upon breach of contract, breach of warranty, negligence, strict liability in tort or any other legal theory. Without limiting the generality of the foregoing. Alloway specifically disclaims any damages relating to (i) lost profits, business, revenues or goodwill; (ii) loss of crops; (iii) loss because of delay in harvesting; (iv) any expense or loss Incurred for labor, supplies, substitute machinery or rental; or (v) any other type of damage to property or economic loss.

This Warranty is subject to any existing conditions of supply, which may directly affect ALLOWAYS' ability to obtain materials or manufacture replacement parts.

No agent, representative, dealer, distributor, serviceperson, salesperson, or employee of any company; including without limitation, ALLOWAY, its authorized dealers, distributors, and service centers, is authorized to alter, modify, or enlarge this Warranty.

This Warranty is effective only if the warranty registration card is returned within ten (10) days.

Answers to any questions regarding warranty service and locations may be obtained by contacting:

Alloway
4230 14th Ave.NW
Fargo, North Dakota 58102
701-356-4983



WARRANTY

ALLOWAY STANDARD, d/b/a ALLOWAY, warrants this product to be free from defect in material and workmanship for a period of One (1) year, ninety (90) days for Service Parts, from the date of delivery of the product to the original purchaser.

Under no circumstances will this Warranty apply in the event that the product, in the good faith opinion of ALLOWAY, has been subjected to improper operation, improper maintenance, misuse, or an accident. This Warranty does not cover normal wear or tear, or normal maintenance items.

This Warranty is extended solely to the original purchaser of the product. Should the original purchaser sell or otherwise transfer this product to a third party, this Warranty does not transfer to the third party purchaser in any way. There are no third party beneficiaries of this Warranty.

ALLOWAY'S' obligation under this Warranty is limited to, at ALLOWAY'S option, the repair or replacement, free of charge, of the product if ALLOWAY, in its sole discretion, deems it, to be defective or in noncompliance with this Warranty. The product must be returned to ALLOWAY with proof of purchase within thirty (30) days after such defect or noncompliance is discovered or should have been discovered, routed through the dealer and distributor from whom the purchase was made, transportation charges prepaid. ALLOWAY shall complete such repair or replacement within a reasonable time after ALLOWAY receives the product. THERE ARE NO OTHER REMEDIES UNDER THIS WARRANTY. THE REMEDY OF REPAIR OR REPLACEMENT IS THE SOLE AND EXCLUSIVE REMEDY UNDER THIS WARRANTY.

THERE ARE NO WARRANTIES WHICH EXTEND BEYOND THE DESCRIPTION ON THE FACE OF THIS WARRANTY. ALLOWAY MAKES NO OTHER WARRANTY, EXPRESS OR IMPLIED, AND ALLOWAY SPECIFICALLY DISCLAIMS ANY IMPLIED WARRANTY OF MERCHANTABILITY AND/OR ANY IMPLIED WARRANTY OF FITNESS FOR A PARTICULAR PURPOSE.

ALLOWAY shall not be liable for any incidental or consequential losses, damages or expenses, arising directly or indirectly from the product, whether such claim is based upon breach of contract, breach, of warranty, negligence, strict liability in tort or any other legal theory. Without limiting the generality of the foregoing, Alloway specifically disclaims any damages relating to (i) lost profits, business, revenues or goodwill; (ii) loss of crops; (iii) loss because of delay in harvesting; (iv) any expense or loss incurred for labor, supplies, substitute machinery or rental; or (v) any other type of damage to property or economic loss.

This Warranty is subject to any existing conditions of supply, which may directly affect ALLOWAYS' ability to obtain materials or manufacture replacement parts.

No agent, representative, dealer, distributor, service person, salesperson, or employee of any company, including without limitation, ALLOWAY, Its authorized dealers, distributors, and service centers, IS authorized to alter, modify, or enlarge this Warranty.

Answers to any questions regarding warranty service and locations may be obtained by contacting:

Alloway
4230 14th Ave.NW
Fargo, North Dakota 58102
701-356-4983



PART NUMBER

507-5-0001



Quality • Innovation

Alloway Standard Industries
4230 14th Avenue NW
Fargo, North Dakota 58102

Local/Intl: 1-701-356-4983
Toll Free: 1-877-275-8714
Fax: 1-701-356-4985