

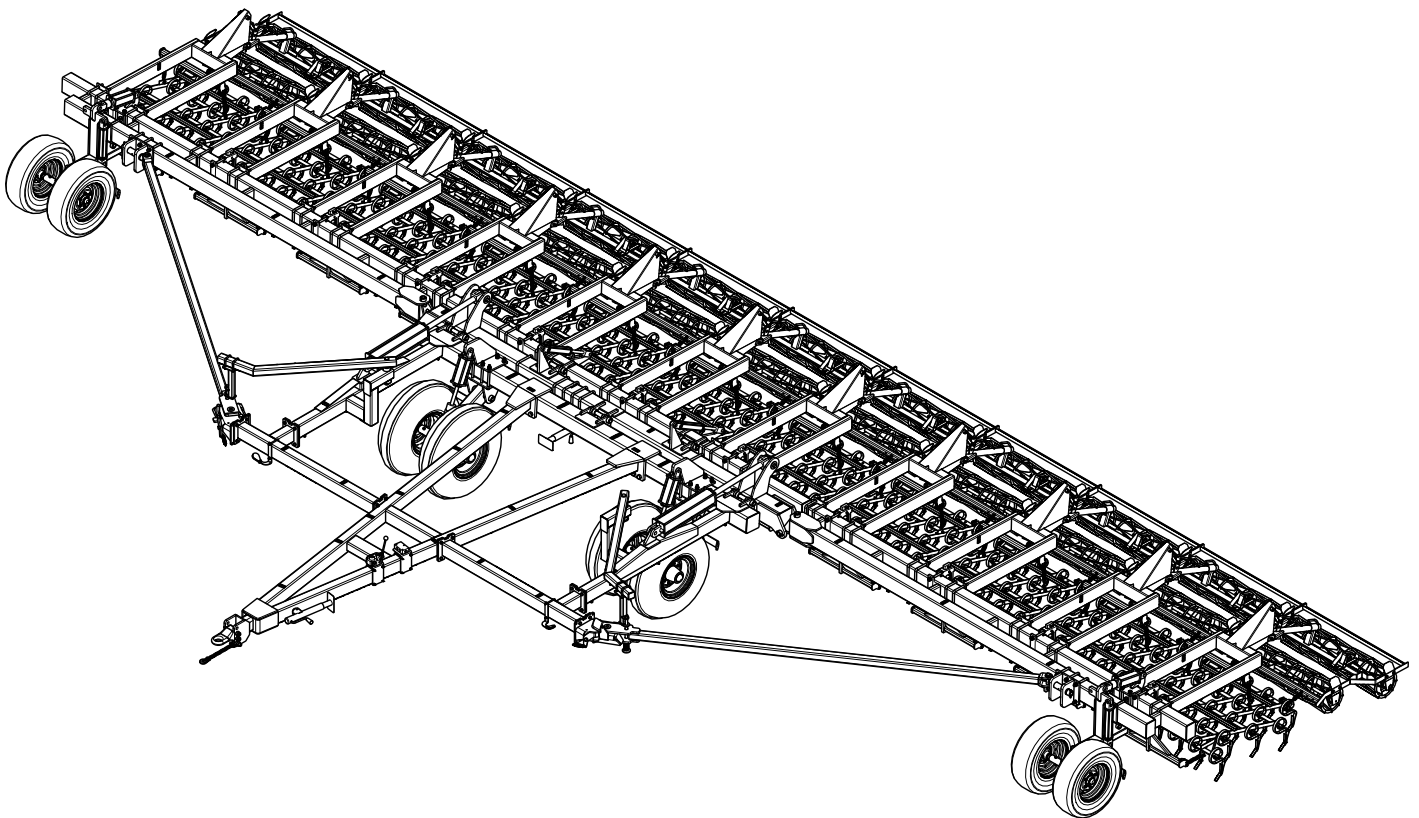

2012

# SEEDBETTER



## OPERATOR'S MANUAL

**TO THE DEALER:**

Assembly and proper installation of this product is the responsibility of the Alloway dealer. Read manual instructions and safety rules. Make sure all items on the Dealer's Pre-Delivery and Delivery Check Lists in the Operator's Manual are completed before releasing equipment to the owner.

The dealer must complete the Warranty Registration included in this manual. Both dealer and customer must sign the registration which certifies that all Dealer Check List items have been completed. The dealer is to return the prepaid postage portion to Alloway, give one copy to the customer, and retain one copy.

**Note: Warranty credit is subject to this form being completed and returned.**

**TO THE OWNER:**

Read this manual before operating your Alloway equipment. The information presented will prepare you to do a better and safer job. Keep this manual handy for ready reference. Require all operators to read this manual carefully and become acquainted with all the adjustment and operating procedures before attempting to operate. Replacement manuals can be obtained from your dealer.

The equipment you have purchased has been carefully engineered and manufactured to provide dependable and satisfactory use. Like all mechanical products, it will require cleaning and upkeep. Lubricate the unit as specified. Observe all safety information in this manual and safety decals on the equipment.

For service, your authorized Alloway dealer has trained mechanics, genuine Alloway service parts, and the necessary tools and equipment to handle all your needs.

Use only genuine Alloway service parts. Substitute parts will void the warranty and may not meet standards required for safe and satisfactory operation. Record the model number and serial number of your equipment in the spaces provided:

**Model:** \_\_\_\_\_ **Date of Purchase** \_\_\_\_\_

**Serial Number: (see Safety Decal section for location)** \_\_\_\_\_

Provide this information to your dealer to obtain correct repair parts.

Throughout this manual, the term **IMPORTANT** is used to indicate that failure to observe can cause damage to equipment. The terms **CAUTION**, **WARNING** and **DANGER** are used in conjunction with the Safety-Alert Symbol, (a triangle with an exclamation mark), to indicate the degree of hazard for items of personal safety.



This Safety-Alert Symbol indicates a hazard and means **ATTENTION! BECOME ALERT! YOUR SAFETY IS INVOLVED!**



Indicates an imminently hazardous situation that, if not avoided, will result in death or serious injury.



**WARNING**

Indicates a potentially hazardous situation that, if not avoided, could result in death or serious injury, and includes hazards that are exposed when guards are removed



**CAUTION**

Indicates a potentially hazardous situation that, if not avoided, may result in minor or moderate injury.

**IMPORTANT**

Indicates that failure to observe can cause damage to equipment.

**NOTE**

Indicates helpful information.



# TABLE OF CONTENTS

INTRODUCTION .....	Inside Front Cover
GENERAL INFORMATION .....	1
SPECIFICATIONS .....	2
SAFETY RULES .....	3-6
SAFETY DECALS .....	8-9
CHECK LISTS .....	10
OPERATOR SIGN-OFF RECORD .....	11
OPERATION.....	13-20
FIELD OPERATION .....	21-22
STORAGE .....	23
SERVICE & MAINTENANCE .....	25-29
TROUBLE SHOOTING .....	30
ASSEMBLY.....	31
INDEX TO PARTS LISTS .....	33
BOLT TORQUE CHART .....	55
ABBREVIATIONS .....	56
INDEX .....	57
REPLACEMENT PARTS WARRANTY .....	58
PRODUCT WARRANTY.....	59

---

## GENERAL INFORMATION

The purpose of this manual is to assist you in operating and maintaining your Alloway Seedbetter. Read it carefully. It furnishes information and instructions that will help you achieve years of dependable performance. These instructions have been compiled from extensive field experience and engineering data. Some information may be general in nature due to unknown and varying operating conditions. However, through experience and these instructions, you should be able to develop procedures suitable to your particular situation.

The illustrations and data used in this manual were current at the time of printing, but due to possible inline production changes, your machine may vary slightly in detail. We reserve the right to redesign and change the machines as may be necessary without notification.

Throughout this manual, references are made to right and left direction. These are determined by standing behind the equipment facing the direction of forward travel.

# SPECIFICATIONS

Maximum Operating Width:

45' ..... 550 in. (14.0 m)  
52' ..... 622 in. (15.8 m)  
62' ..... 754 in. (19.2 m)

Maximum Transport Width:

45' ..... 225 in. (5.8 m)  
52' ..... 225 in. (5.8 m)  
62' ..... 225 in. (5.8 m)

Maximum Operating Length:

45' ..... 333 in. (8.5 m)  
52' ..... 333 in. (8.5 m)  
62' ..... 333 in. (8.5 m)

Maximum Transport Length:

45' ..... 384 in. (9.8 m)  
52' ..... 426 in. (10.8 m)  
62' ..... 486 in. (12.4 m)

Maximum Transport Height:

45' ..... 164 in. (4.2 m)  
52' ..... 164 in. (4.2 m)  
62' ..... 164 in. (4.2 m)

Recommended Tire Size: ..... Multi-Rib (11.0 x 16) or Implement (9.50 x 15)

Recommended Tire Inflation Pressure:

9.50 x 15 ..... 35 psi.  
11.0 x 16 ..... 35 psi.

Tractor Horse Power ..... 250 Horsepower Minimum

Weight of Seedbetter (approximate):

45' ..... 15000 lbs. (6800 kg)  
52' ..... 16000 lbs. (7300 kg)  
62' ..... 17300 lbs. (7900 kg)





# SAFETY RULES

## ATTENTION! BECOME ALERT! YOUR SAFETY IS INVOLVED!



Safety is a primary concern in the design and manufacture of our products. Unfortunately, our efforts to provide safe equipment can be wiped out by a single careless act of an operator.

In addition to the design and configuration of equipment, hazard control and accident prevention are dependent upon the awareness, concern, prudence and proper training of personnel involved in the operation, transport, maintenance and storage of equipment.

It has been said *"The best safety device is an informed, careful operator."* We ask you to be that kind of an operator.

The designed and tested safety of this equipment depends on it being operated within the limitations as explained in this manual.

### TRAINING

- **Safety instructions are important! Read all attachment and power unit manuals; follow all safety rules and safety decal information. (Replacement manuals are available from dealer). Failure to follow instructions or safety rules can result in serious injury or death.**
- **If you do not understand any part of this manual and need assistance, see your dealer.**
- **Know your controls and how to stop engine and attachment quickly in an emergency.**
- **Operators must be instructed in and be capable of the safe operation of the equipment, its attachments and all controls. Do not allow anyone to operate this equipment without proper instructions.**
- **Keep hands and body away from pressurized lines. Use paper or cardboard, not body parts to check for leaks. Wear safety goggles. Hydraulic fluid under pressure can easily penetrate skin and will cause serious injury or death.**
- **Make sure that all operating and service personnel know that in the event hydraulic fluid penetrates skin, it must be surgically removed as soon as possible by a doctor familiar with this form of injury, or gangrene, serious injury or death will result. CONTACT A PHYSICIAN IMMEDIATELY IF FLUID ENTERS SKIN OR EYES. DO NOT DELAY**

- **Never allow children or untrained persons to operate equipment.**

---

### PREPARATION

- **Check that all hardware is tight and properly installed. Always tighten to torque chart specifications unless instructed otherwise in this manual.**
- **Air in hydraulic systems can cause erratic operation and allow loads or equipment components to drop unexpectedly. Before operating or allowing anyone to approach the equipment, purge any air in the system by operating all hydraulic functions several times after connecting equipment, connecting hoses, or doing any hydraulic maintenance.**
- **Make sure all hydraulic hoses, fittings and valves are in good condition and not leaking before starting power unit or using equipment. Check and route hoses carefully to prevent damage. Hoses must not be twisted, bent sharply, kinked, frayed, pinched, or come into contact with any moving parts. Operate moveable components through full operational range to check clearances. Replace any damaged hoses immediately.**
- **Always wear relatively tight and belted clothing to avoid entanglement in moving parts. Wear sturdy, rough-soled work shoes and protective equipment for eyes, hair, hands, hearing, and head; and respirator or filter mask where appropriate.**
- **Ensure implement is properly attached, adjusted and in good operating condition.**
- **Power unit must be equipped with ROPS or ROPS CAB and seat belt. Keep seat belt securely fastened. Falling off power unit can result in death from being run over or crushed. Keep foldable ROPS systems in "locked up" position at all times.**
- **Remove accumulated debris from this equipment, tractor and engine to avoid fire hazard.**

*(Safety Rules continued on next page)*



# SAFETY RULES

## ATTENTION! BECOME ALERT! YOUR SAFETY IS INVOLVED!



*(Safety Rules continued from previous page)*

■ A minimum 20% of tractor and equipment weight must be on tractor front wheels when attachments are in transport position. Without this weight, tractor could tip over, causing personal injury or death. The weight may be attained with a loader, front wheel weights, ballast in tires or front tractor weights. When attaining the minimum 20% weight on the front wheels, you must not exceed the Roll Over Protection Structure (ROPS) weight certification. Weigh the tractor and equipment. Do not estimate.

■ Make sure hydraulic hoses and cylinders are fully purged of air before operating. Keep all person away and fill the system by raising and lowering all functions several times. Air in the system can allow components to fall unexpectedly.

---

### TRANSPORTING

■ Power unit must be equipped with ROPS or ROPS CAB and seat belt. Keep seat belt securely fastened. Falling off power unit can result in death from being run over or crushed. Keep foldable ROPS systems in "locked up" position at all times

■ Always sit in power unit seat when operating controls or starting engine. Securely fasten seatbelt, place transmission in neutral, engage brake, and ensure all other controls are disengaged before starting power unit engine.

■ A minimum 20% of tractor and equipment weight must be on the tractor front wheels when attachments are in transport position. Without this weight, tractor could tip over, causing personal injury or death. The weight may be attained with a loader, front wheel weights, ballast in tires, or front tractor weights. Weigh the tractor and equipment, Do not estimate.

■ Always attach safety chain to tractor drawbar when transporting unit.

■ Never exceed 20 MPH during transport. See the Speed vs. Weight Ratio Table in "Field Operation, Transporting the Unit" for proper tow vehicle to machine weight ratios.

■ Watch for hidden hazards on the terrain.

■ Always comply with all state and local lighting and marking requirements.

■ Never allow riders on power unit or attachment.

■ Look down and to the rear to make sure area is clear before operating in reverse.

■ Do not operate or transport on steep slopes.

■ Use extreme care and reduced ground speed on slopes and rough terrain.

■ Do not operate or transport equipment while under the influence of alcohol or drugs.

---

### OPERATION

■ Do not allow bystanders in the area when operating, attaching, removing, assembling, or servicing equipment.

■ Do not allow anyone to stand between tractor and unit when backing up to unit.

■ Never go underneath equipment (lowered to the ground or raised) unless it is properly blocked and secured. Never place any part of the body underneath equipment or between movable parts even when the engine has been turned off. Hydraulic system leak down, hydraulic system failures, mechanical failures, or movement of control levers can cause equipment to drop or rotate unexpectedly and cause severe injury or death. Follow Operator's Manual instructions for working underneath and blocking requirements or have work done by a qualified dealer.

*(Safety Rules continued on next page)*



# SAFETY RULES

## ATTENTION! BECOME ALERT! YOUR SAFETY IS INVOLVED!



*(Safety Rules continued from previous page)*

- Keep bystanders away from equipment
- Do not operate or transport equipment while under the influence of alcohol or drugs.
- Operate only in daylight or good artificial light.
- Avoid contact with electrical wires.
- Always comply with all state and local lighting and marking requirements.
- Power unit must be equipped with ROPS or ROPS CAB and seat belt. Keep seat belt securely fastened. Falling off power unit can result in death from being run over or crushed. Keep foldable ROPS systems in "locked up" position at all times.
- Always set in power unit seat when operating controls or starting engine. Securely fasten seat belt, place transmission in neutral, engage brake, and ensure all other controls are disengaged before starting power unit engine.
- Look down and to the rear and make sure area is clear before operating in reverse. Do not operate or transport on steep slopes.
- Do not stop, start, or change directions suddenly on slopes.
- Use extreme care and reduced ground speed on slopes and rough terrain.
- Watch for hidden hazards on the terrain during operation.
- Always connect safety chain from equipment to towing vehicle when transporting.
- **AVOID INJURY OR DEATH FROM POWER LINES:**
  - ◆ Stay away from power lines
  - ◆ Electrocutation can occur without direct contact.
  - ◆ Check clearances before raising implement
  - ◆ Do not leave the operator's seat if any

part of the tractor or implement contacts electric lines.

- Before servicing, adjusting, repairing or unplugging, stop tractor engine, place all controls in neutral, set park brake, remove ignition key, and wait for all moving parts to stop.
- Before working underneath a raised implement, read and follow all Operator's Manual instructions and safety rules. Implement must be attached to tractor. Hydraulic system lead down, hydraulic system failures, or movement of controls levers can cause equipment to drop unexpectedly and cause severe injury or death.

---

## MAINTENANCE

- Before servicing, adjusting, repairing, or unplugging, stop tractor engine, place all controls in neutral, set park brake, remove ignition key, and wait for all moving parts to stop.
- Before working underneath a raised implement, read and follow all Operator's Manual instructions and safety rules. Implement must be attached to tractor. Hydraulic system leak down, hydraulic system failures, or movement of control levers can cause equipment to drop unexpectedly and cause severe injury or death.
- Service and maintenance work not covered in OWNER SERVICE must be done by a qualified dealership. Special skills, tools, and safety procedures may be required. Failure to follow these instructions can result in serious injury or death.
- Do not modify or alter or permit anyone else to modify or alter the equipment or any of its components in any way.
- Your dealer can supply original equipment hydraulic accessories and repair parts. Substitute parts may not meet original equipment specifications and may be dangerous.

*(Safety Rules continued on next page)*



# SAFETY RULES

## ATTENTION! BECOME ALERT! YOUR SAFETY IS INVOLVED!



*(Safety Rules continued from previous page)*

- Always wear relatively tight and belted clothing. Wear sturdy, rough-soled work shoes and protective equipment for eyes, hair, hands, hearing and head; and respirator or filter mask where appropriate.
- Do not allow other people in the area when operating, attaching, removing, assembling or servicing equipment.
- Never go underneath equipment lowered to the ground or raised, unless it is properly blocked and secured. Never place any part of the body underneath equipment or between moveable parts even when the engine has been turned off. Hydraulic system leak down, hydraulic system failures, mechanical failures or movement of control levers can cause equipment to drop or rotate unexpectedly and cause severe injury or death. Follow Operator's Manual instructions for working underneath and blocking requirements, or have work done by a qualified dealer.
- Ensure implement is properly attached, adjusted and in good operating condition.
- Make sure hydraulic hoses and cylinders are fully purged of air before operating. Keep all persons away and fill the system by raising and lowering all functions several times. Air in the system can allow components to fall unexpectedly.
- Keep all person away from operator control area while performing adjustments, service, or maintenance.
- Ensure all safety decals are installed. Replaced if damaged. (See Safety Decals section for location)
- Do not disconnect hydraulic lines until machine is securely blocked or placed in lowest position and system pressure is released by operating all valve control levers.

---

## STORAGE

- Follow manual instructions for storage.
- Keep children and bystanders away from storage area.





# SAFETY & INSTRUCTIONAL DECALS

ATTENTION! BECOME ALERT! YOUR SAFETY IS INVOLVED!  
Replace Immediately If Damaged!

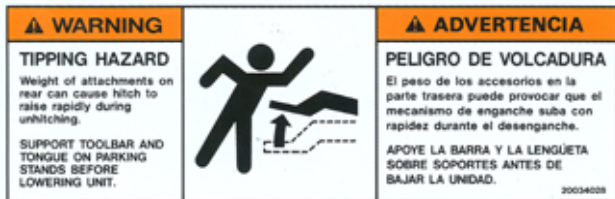
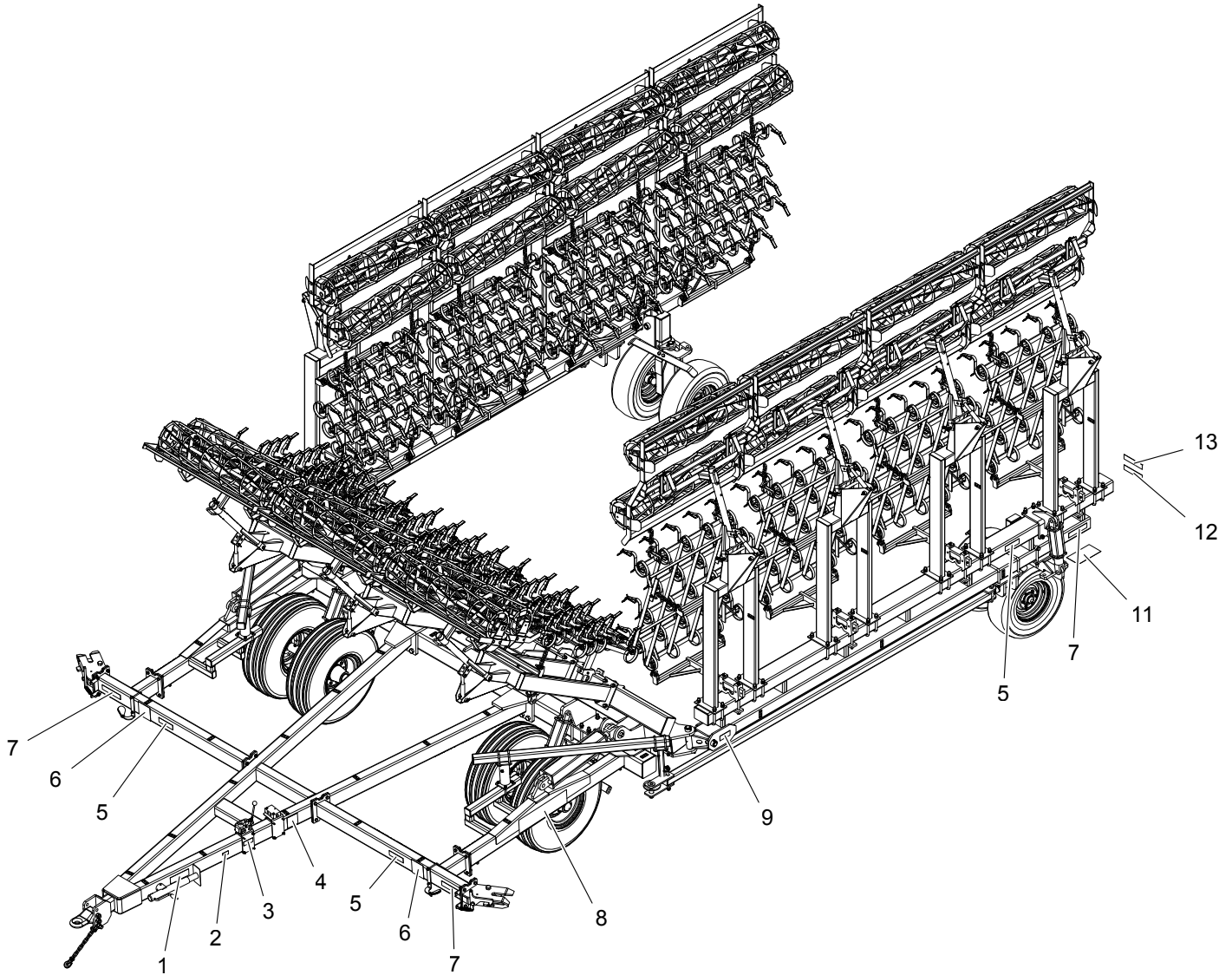

1. 200-3-4028 Cultivator Hitch Warning



2. 200-3-1366 Serial Number Tag



# SAFETY & INSTRUCTIONAL DECALS

## ATTENTION! BECOME ALERT! YOUR SAFETY IS INVOLVED!

Replace Immediately If Damaged!



3. 210-3-5013 Turn / Lift Valve

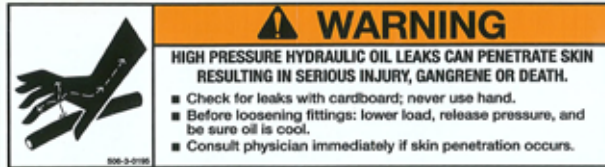

5. 506-3-0195 Hydraulic Pressure Warning



7. 200-3-4004 Amber Reflector 9 x 2



12. 200-3-4034 Orange Fluorescent Reflector 9 x 2



13. 200-3-4005 Red Reflector 9 x 2

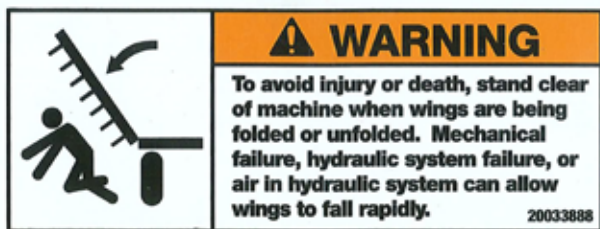

9. 200-3-3888 Cultivator Wing Fall Warning



4. 200-3-3911 Read Manual Warning



6. 200-3-3887 Cultivator Fall / Crush Warning

# ALLOWAY

## SEEDBETTER-5200

8. 210-3-5012 Seedbetter 5200



11. 902-15101 Alloway Standard Logo

# CHECK LISTS

## PRE-DELIVERY CHECK LIST (DEALER'S RESPONSIBILITY)

Inspect the equipment thoroughly after assembly to ensure it is set up properly before delivering it to the customer.

The following check lists are a reminder of points to inspect. Check off each item as it is found satisfactory or after proper adjustment is made.

- Check that all safety decals are installed and in good condition. Replace if damaged.
- Properly attach implement to tractor and make all necessary adjustments.
- Check all bolts to be sure they are tight.
- Check wheel bolts for proper torque.
- Check that all cotter pins and safety pins are properly installed. Replace if damaged.
- Check and grease all lubrication points as identified in "Service, lubrication information."
- Check the level of gearbox fluids before delivery. Service, if required, as specified in the "Service, lubrication information."
- Check that tractor hydraulic reservoir has been serviced and that hydraulic system and all functions have been operated through full cylinder stroke to purge air from system.
- After pressurizing and operating all Seedbetter functions, stop tractor and make sure there are no leaks in the hydraulic system. Follow all safety rules when checking for leaks.

## DELIVERY CHECK LIST (DEALER'S RESPONSIBILITY)

- Show customer how to make adjustments.
- Instruct customer how to lubricate and explain importance of lubrication.
- Point out the safety decals. Explain their meaning and the need to keep them in place and in good condition. Emphasize the increased safety hazards when instructions are not followed.
- Present Operator's Manual and request that customer and all operators read it before operating equipment. Point out the manual safety rules, explain their meanings and emphasize the increased safety hazards that exist when safety rules are not followed.
- Extended & Retracted Length.
- Show customer the safe, proper procedures to be used when mounting, dismounting, and storing equipment.
- Explain to customer that when equipment is transported on a road or highway, safety devices should be used to give adequate warning to operators of other vehicles.
- Explain to customer that when equipment is transported on a road or highway, a Slow Moving Vehicle (SMV) sign should be used to provide adequate warning to operators of other vehicles.
- Explain to customer that when towing on a public road to comply with all state and local lighting/marketing laws and to use a safety tow chain.
- Make customer aware of optional equipment available so that customer can make proper choices as required.







# OPERATION

Safety is a primary concern in the design and manufacture of our products. Unfortunately, our efforts to provide safe equipment can be wiped out by an operator's single careless act.

In addition to the design and configuration of equipment, hazard control and accident prevention are dependent upon the awareness, concern, judgment, and proper training of personnel involved in the operation, transport, maintenance and storage of equipment.

It has been said "The best safety device is an informed, careful operator." We ask you to be that kind of operator.

- Be familiar with the Seedbetter before starting.
- The owner is responsible for training operators in the safe operation of the Seedbetter.



## WARNING

- **Safety instructions are important! Read all attachment and power unit manuals; follow all safety rules and safety decal information. (Replacement manuals are available from your Alloway dealer.) Failure to follow instructions or safety rules can result in serious injury or death.**
- **Never allow children or untrained persons to operate equipment.**
- **Keep hands, feet, hair, and clothing away from equipment while engine is running. Stay clear of all moving parts.**
- **Before dismounting power unit or performing any service or maintenance, follow these steps: disengage power to equipment, lower the 3-point hitch and all raised components to the ground, operate valve levers to release any hydraulic pressure, set parking brake, stop engine, remove key, and unfasten seat belt.**
- **Never allow riders on power unit or attachment.**
- **Do not allow bystanders in the area when operating, attaching, removing, assembling, or servicing equipment.**
- **Keep hands, feet, hair, and clothing away from equipment while engine is running. Stay clear of all moving parts.**



## CAUTION

- **Always sit in power unit seat when operating controls or starting engine. Securely fasten seat belt, place transmission in neutral, engage brake, and ensure all other controls are disengaged before starting power unit engine.**
- **Never allow riders on power unit or attachment**
- **Keep bystanders away from equipment.**
- **Always comply with all state and local lighting and marking requirements.**
- **Always wear relatively tight and belted clothing to avoid entanglement in moving parts. Wear sturdy, rough-soled work shoes and protective equipment for eyes, hair, hands, hearing, and head; and respirator or filter mask where appropriate.**

## Operation Continued

### PRINCIPAL COMPONENTS

The Alloway Seedbetter consists of rear folding harrow frames, individual tine assemblies, and rolling baskets. The Seedbetter combines the right tine with the perfect crumbler basket to do a complete job every time you work your field. The finishing harrows are for medium to shallow penetration. A uniquely styled spring tine with vibrating action to clear in trashy conditions. The

steep breasted tines have a superior mixing action and do not create lumps. The pressurized crumbler sections level, mix, crumble, form a seed horizon and keep wind erosion down.

The Seedbetter is designed to be used as a pull-type mounted machine.

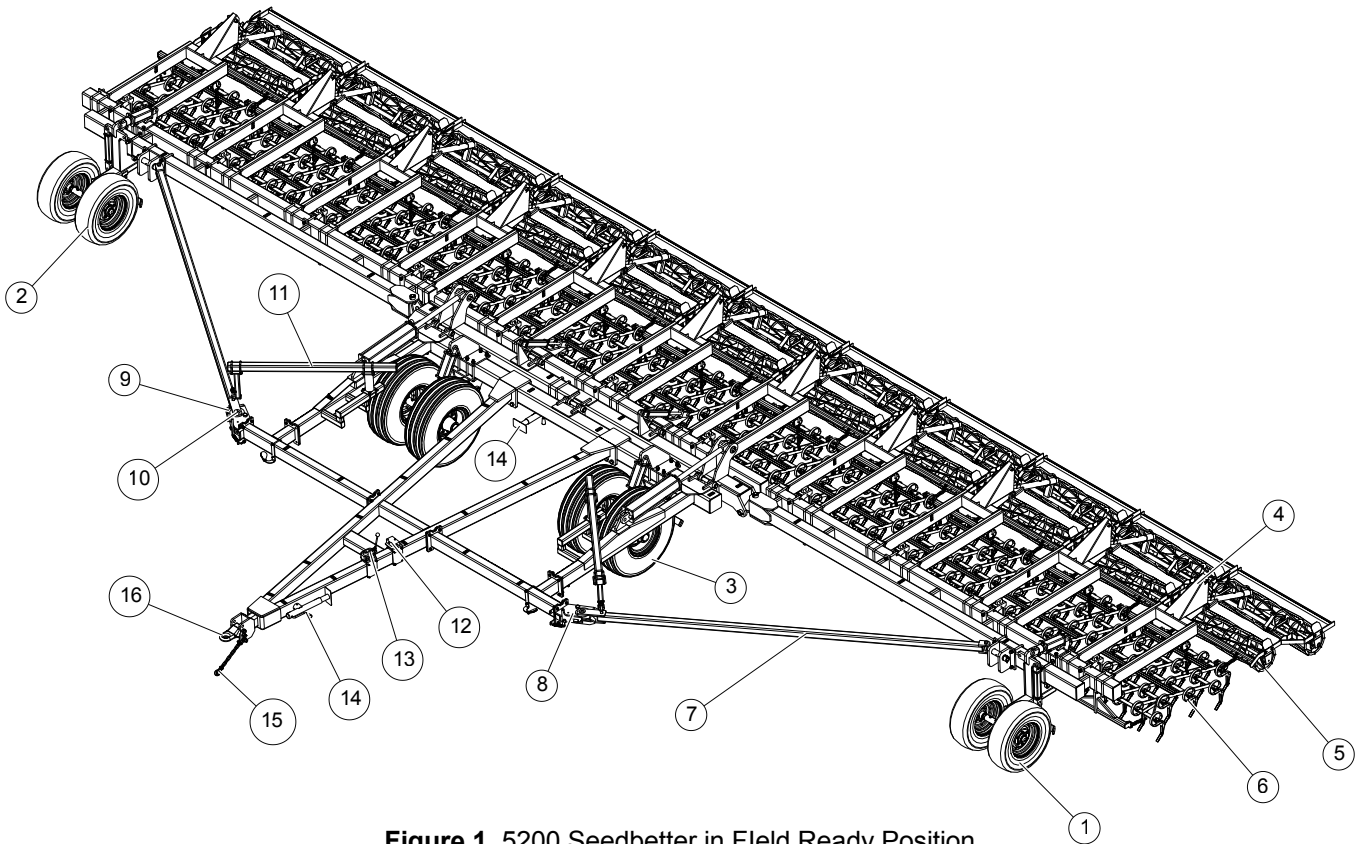

Figure 1. 5200 Seedbetter in Field Ready Position

- |                          |                      |
|--------------------------|----------------------|
| 1. Wing Wheel Strut - LH | 9. Wing Latch - RH   |
| 2. Wing Wheel Strut - RH | 10. Wing Support Pin |
| 3. Main Strut            | 11. Wing Support Arm |
| 4. H-Frame               | 12. Selector Valve   |
| 5. Crumbler Basket       | 13. Selector Valve   |
| 6. Harrow                | 14. Jack             |
| 7. Wing Support Tube     | 15. Safety Tow Chain |
| 8. Wing Latch - LH       | 16. Hitch            |

## Operation Continued

### PRE-OPERATION CHECK LIST (OWNER'S RESPONSIBILITY)

#### IMPORTANT

■ This Pre-Operation Check List is provided for the operator. It is important to follow for both personal safety and maintenance of the Seedbetter.

- \_\_\_ Check all lubrication points and grease as instructed in Lubrication Schedule.
- \_\_\_ Use only a tractor of adequate power and weight to pull the unit.

- \_\_\_ Check that the unit is properly attached to the tractor. On pull-type unit, be sure there is a mechanical retainer through the drawbar pin and the safety chain is installed.
- \_\_\_ Check tire pressure. Bring to specified level.
- \_\_\_ Inspect all hydraulic lines, hoses, couplers, and fittings. Tighten, repair, or replace any leaking or damaged components.

---

### Choosing the Correct Equipment

To ensure safe and reliable operation of the Seedbetter, use a tractor with the correct specifications. Use the following guidelines to select the correct tractor.

#### 1. Horsepower

Use Table 1 for selecting the tractor horsepower class appropriate for your unit's width.

Increase the horsepower level by 25 percent when operating in hilly, soft, or wet conditions.

#### 2. Tractor Weight

By following recommendations for tractor horsepower, the tractor will have sufficient weight to provide stability for unit during field operation or when transporting.

It is recommended that each tractor be equipped with a full complement of suitcase weights on the tractor front (see Figure 2 for example). This will provide the required front weight for turning and extra traction if equipped with front wheel assist.

Width	Minimum Horsepower
42'	225
52'	250
62'	275

Table 1: Tractor Horsepower vs. Unit Width



Figure 2. Front Suitcase Weights

## Operation *Continued*

### Attaching the Seedbetter to the Tractor

- Do not allow anyone to stand between tractor and unit when backing up to the unit.



#### WARNING

- Keep bystanders away from equipment

1. Place unit on a level, dry area free of debris and other foreign object.
2. Use clevis style hitch on the tractor. Lock the tractor drawbar in the center position.



#### CAUTION

- Do not allow anyone to stand between tractor and unit when backing up to the unit.

3. Provide enough clearance to back the tractor safely into the unit.
4. Use the implement jacks, found on the front hitch and back of center section of the toolbar, to level hitch height to tractor drawbar.
5. Back slowly and align the drawbar with the hitch.
6. Shut off the tractor, place all controls in neutral, set the parking brake, remove the key, and wait for all moving parts to stop.
7. Use ratchet on back of toolbar to set hitch height.

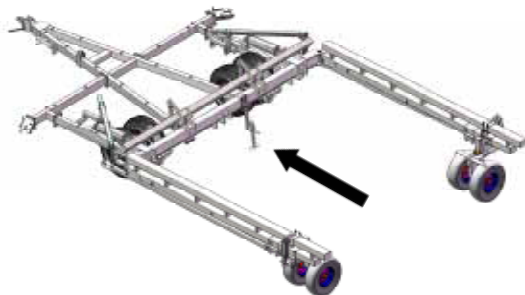
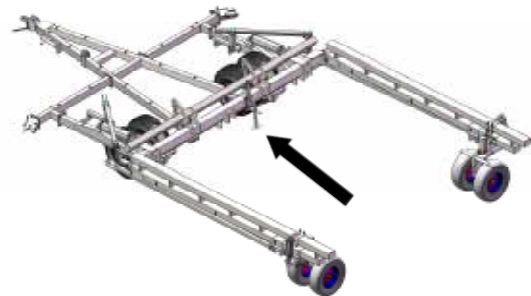

**Figure 3.** Jack in adjustment position (DOWN)

8. Use the hardened drawbar pin with provisions for a mechanical retainer, install a retainer, such as a Klick pin.

9. Attach the safety chain around the drawbar or cage to prevent unexpected separation. Provide sufficient slack for turning.

10. Replace ratchet on back of toolbar into transport positions.



**Figure 4.** Jack in field / transport position (UP)

---

### Connecting the Hydraulics

1. Use a clean cloth or paper towel to clean the couplers on the end of the hoses and the area around the couplers on the tractor.
2. Insert the male ends into the couplers on the tractor. Be sure they are locked in place.

## Operation *Continued*

### Unfolding Machine into Field Position



**WARNING**



**CAUTION**

- Stay Clear of Seedbetter when wings are being raised or lowered. Hydraulic or Mechanical failure can result in a rapid, uncontrolled falling of wings, hitch jump or spring back. Failure to follow these instructions may result in serious injury or death.

#### Step: 1

Check valve on unit to insure it is in Transport Position.



Figure 6. Valve in Transport Position

#### Step: 2

Turn wing wheels approximately 45° angle from Transport Position. Start backing machine up, this will start folding the wings forward. While backing up turn the wheels to the full 90° position. This will help push wing completely forward.

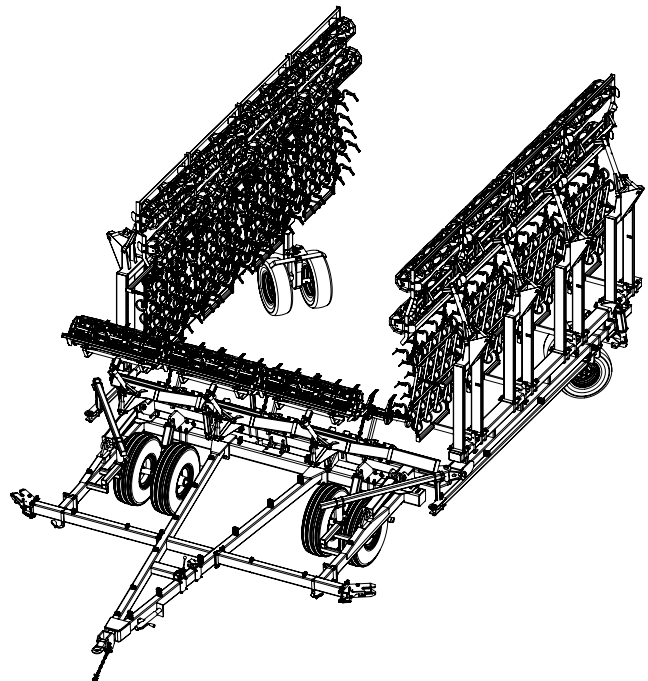

Figure 7. Wheels turned 45° for unfolding

## Operation *Continued*

### Unfolding Machine into Field Position

#### Step: 3

When toolbar is straight, start folding the unit to the ground. When it is approximately at a 20° angle from the ground. Back the tractor up slightly, making sure the wing locks are snapped over the pin lock securely.

#### **NOTE:**

**Center Section Drop Speed can be adjusted with needle valve to control rate of drop to reduced chance of machine damage.**

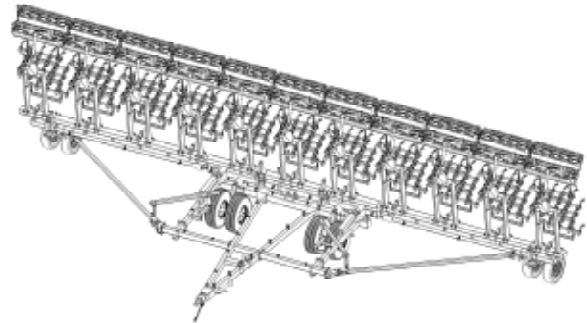

**Figure 8.** Toolbar Straight w/ Wheels in Field Position

#### Step: 4

Continue to lower machine to the ground.



**Figure 9.** Pin in Locked Position

#### Step: 5

Turn off tractor. Change valve position to field ready. This will allow to raise or lower wing wheels.



**Figure 10.** Valve in Field Ready Position



## Operation *Continued*

### Folding Machine into Transport Position



**WARNING**



**CAUTION**

- **Stay Clear of Seedbedder when wings are being raised or lowered. Hydraulic or Mechanical failure can result in a rapid, uncontrolled falling of wings, hitch jump or spring back. Failure to follow these instructions may result in serious injury or death.**

#### Step: 1

Stop the tractor before attempting to fold unit into Transport Position.

#### Step: 2

Move selector valve to Transport Position.



**Figure 11.** Valve in Transport Position

#### Step: 3

Raise the unit 90° from the ground, while doing so this will release wing latches.

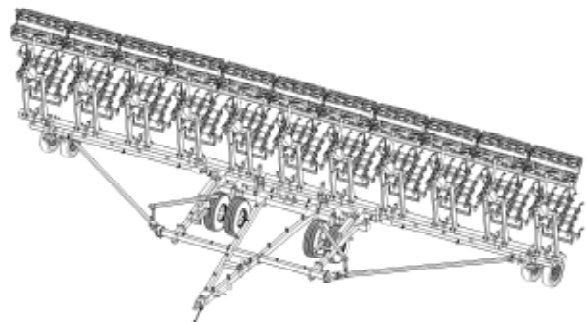

**Figure 12.** Toolbar Straight w/ Wheels in Field Position

## Operation *Continued*

### Folding Machine into Transport Position

#### Step: 4

Turn wheels approximately 45° from Field Position. Start moving forward, this will start unfolding the wings backward. While moving forward turn the wheels to the full 90° position. This will help push wings completely backward.

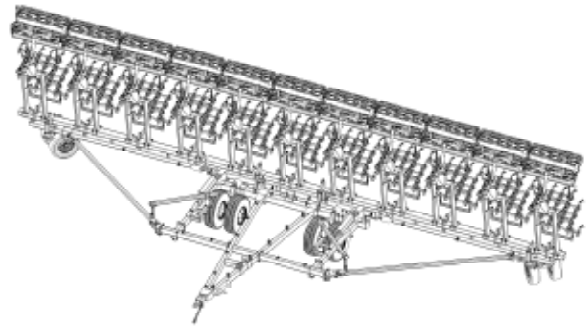

**Figure 13.** Toolbar Straight w/ Wheels turned 45°

#### Step: 5

Make sure all components look transport ready. Check all lights and slow moving vehicle sign.

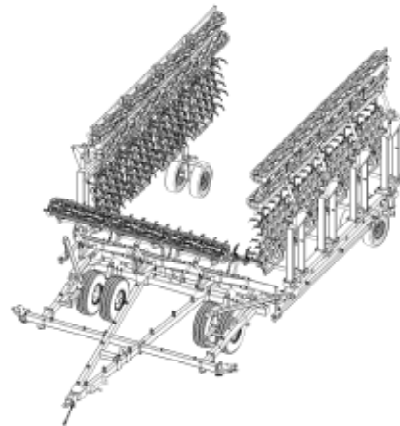

**Figure 14.** Toolbar folded back w/ wheels in Transport Position

# FIELD OPERATION

The Alloway Seedbetter is designed with the flexibility to operate well in almost any kind of crop and terrain condition. However, the operator is responsible for being familiar with all operating and safety procedures and following them.

Each operator should review this Field Operation section at the start of the season and as often as required to be familiar with the unit.

Operators should also review the PRE-OPERATION CHECK LIST. Attaching the Seedbetter to the tractor and transporting the unit.



## WARNING

- **Safety instructions are important! Read all attachment and power unit manuals; follow all safety rules and safety decal information. (Replacement manuals are available from your Alloway dealer.) Failure to follow instructions or safety rules can result in serious injury or death.**
- **Never allow children or untrained persons to operate equipment.**
- **Keep hands, feet, hair, and clothing away from equipment while engine is running. Stay clear of all moving parts.**
- **Before dismounting the power unit or performing any service or maintenance, follow these steps: disengage power to equipment, lower all raised components to the ground, operate valve levers to release any hydraulic pressure, set parking brake, stop engine, remove key, and unfasten seat belt.**
- **Never allow riders on power unit or attachment.**
- **Do not allow bystanders in the area when operating, attaching, removing, assembling, or servicing equipment.**
- **Operators must be instructed in and be capable of the safe operation of the equipment, its attachments, and all controls. Do not allow anyone to operate this equipment without proper instructions.**



## CAUTION

- **Always sit in power unit seat when operating controls or starting engine. Securely fasten seat belt, place transmission in neutral, engage brake, and ensure all other controls are disengaged before starting power unit engine.**
- **Keep bystanders away from equipment.**
- **Always comply with all state and local lighting and marking requirements.**
- **Always wear relatively tight and belted clothing to avoid entanglement in moving parts. Wear sturdy, rough-soled work shoes, and protective equipment for eyes, hair, hands, hearing, and head; and respirator or filter masks where appropriate.**

## Field Operation *Continued*

### Transporting the Unit



#### WARNING

- Never allow riders on power unit or attachment.



#### CAUTION

- Always comply with all state and local lighting and marking requirements.

Road Speed	Fully equipped or loaded implement(s) weight relative to towing machine weight
Up to 20 mph (32 km/h)	1 to 1 or less
Up to 10 mph (16 km/h)	2 to 1 or less
Do not tow	more than 2 to 1

**Table 2: Speed vs Weight Ratio**

1. Be sure all bystanders are clear of the unit.
2. Be sure the unit is securely attached to the tractor and all retainer pins are installed.
3. Be sure safety chain is installed.
4. Clean the SMV emblem, lights, and reflectors and be sure they are working.
5. Be sure you are in compliance with all applicable lighting and marking regulations when transporting. Check with your local authorities.
6. Never transport the unit faster than 20 mph (32 km/h). The ratio of the tractor weight to the seedbed weight plays an important role in defining acceptable travel speed. Table 2 summarizes the recommended travel to speed-to-weight ratio.
7. Be sure all jack stands are in transport position.
8. If wing wheels want to ride out too far, use hydraulics to turn and run them in narrower.

---

### Ground Speed

Travel speed can vary between 6 and 10 mph depending on the soil and the terrain conditions. The operator is responsible for noting the condition of the work, setting speed to obtain a quality tilling job, and maintaining control of the unit.

## Field Operation *Continued*

### Storage



#### **WARNING**

- **Block equipment securely for storage.**
- **Keep children and bystanders away from storage area.**

At the end of the season, the Seedbetter should be thoroughly inspected and prepared for storage. Repair or replace any worn or damage components to prevent unnecessary down time at the beginning of the next season.

To ensure a long, trouble-free life, prepare the unit for storage by carrying out the following procedure:

1. Clear the area of bystanders, especially children.
2. Thoroughly wash the unit, using a pressure washer to remove all dirt, mud, debris, and residue.
3. Inspect for damage or entangled material. Remove entangled material. Repair or replace damaged parts.
4. Inspect all hydraulic hoses, lines, couplers, and fittings. Tighten all loose fittings. Replace any hose that is cut, nicked, abraded, or separating from the crimped end of a fitting.

5. Lubricate all grease fittings. Make sure all grease cavities have been filled with grease to remove any water residue from from pressure washing.

6. Touch up all paint nicks and scratches to prevent rust.

7. Move to storage area. Select a dry area free of debris. Store in an area away from human activity.

8. Unhook from tractor.

**NOTE:** Do not deflate tires.

9. If the unit cannot be placed indoors, cover with a waterproof tarpaulin and tie securely. Store away from human activity

10. Do not allow children to play on or around the stored unit.



# SERVICE & MAINTENANCE



## WARNING

■ Before dismounting power unit or performing any service or maintenance, follow these steps:

- Disengage power to equipment.
- Lower all raised components to the ground.
- Operate valve levers to release any hydraulic pressure.
- Set parking brake.
- Stop engine.
- Remove key.
- Unfasten seat belt.

■ Before working underneath, read manual instructions, securely block up, and check stability. Secure blocking prevents equipment from dropping due to hydraulic leak down, hydraulic system failure, or mechanical component failure.

■ Keep all persons away from operator control area while performing adjustments, service or maintenance.



## CAUTION

■ Always wear relatively tight and belted clothing to avoid entanglement in moving parts. Wear sturdy, rough-soled work shoes and protective equipment for eyes, hair, hands, hearing, and head; and respirator or filter mask where appropriate.

■ Make certain all movement of equipment components has stopped before approaching for service.

## LUBRICANTS

Use the Lubrication Service Record (Page 36), to keep a record of all scheduled maintenance.

### 1. Grease

Use and SAE multi-purpose high temperature grease with extreme pressure (EP) performance. A SAE multi-purpose lithium-based grease is also acceptable.

### 2. Storing Lubricants

Your unit can operate at top efficiency only if clean lubricants are used. Use clean containers to handle all lubricants. Store them in an area protected from dust, moisture, and other contaminants.

## GREASING

Use the Lubrication Service Record (Page 36), to keep a record of all scheduled maintenance.

1. Use a hand-held grease gun for all greasing.

2. Wipe grease fitting with a clean cloth before greasing to avoid injecting dirt and grit.

3. Replace and repair broken fittings immediately.

4. If fittings will not take grease, remove and clean thoroughly. Also clean lubricant passageway. Replace fitting if necessary.

# Service & Maintenance *Continued*

## Lubrication Schedule

**NOTE:** Recommendations are based on normal operating conditions. Severe or unusual conditions may require more frequent lubrication or oil changes. Refer to Figure 30.

- A. Daily or 12 hours
- B. 25 hours
- C. 40 hours
- D. Annually

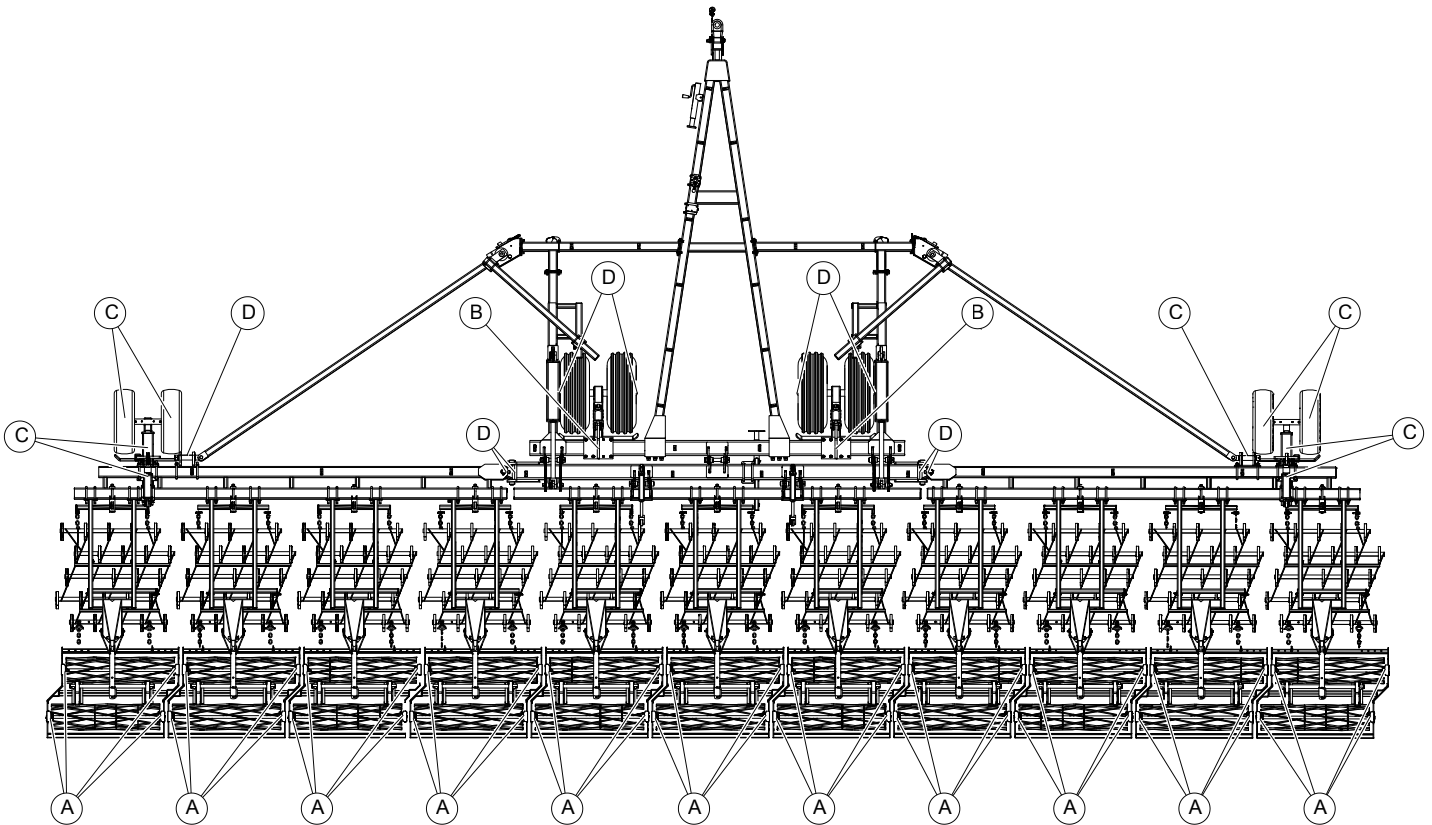

**Figure 30.** Lubrication Points

### Daily or every 12 hrs of operation

1. Use a hand-held grease gun for all greasing.



**Figure 31.** Crumbler Basket Grease Location



## Service & Maintenance *Continued*

### Lubrication Schedule *Continued*

#### Every 25 hrs of operation

1. Use a hand-held grease gun for all greasing.



**Figure 32.** Main Strut Pivot Grease Location

#### Every 40 hrs of operation

1. Use a hand-held grease gun for all greasing.

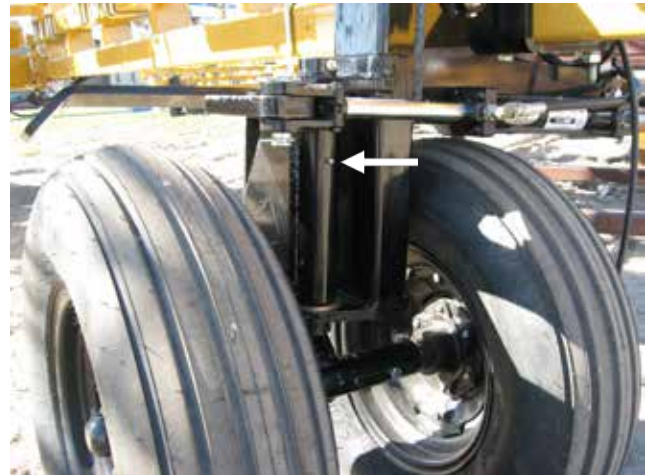

**Figure 33.** Wing Strut Pivot Grease Location



**Figure 34.** Wing Strut Hinge Grease Location



**Figure 35.** 5-Bolt Hub Grease Location

## Service & Maintenance *Continued*

### Lubrication Schedule *Continued*

#### Annually

1. Use a hand-held grease gun for all greasing.



**Figure 36.** Wing Support Pivot Grease Location



**Figure 37.** Main Strut Bearing Grease Location



**Figure 38.** Wing Pivot Grease Locations

# Service & Maintenance *Continued*

## Lubrication Service Record

**NOTE:** See prior pages for details.  
Copy this page to continue service record.

✓ = CHECK  
L = LUBRICATE

C = CHANGE  
R = REPACK

Date:	Serviced By:	10 Hours or Daily		25 Hours		40 Hours			Annually		
		L Crumbler Baskets		L Main Strut Pivots		L Wing Strut Pivot	L Wing Strut Hinge	L Wing Strut Wheels	L Wing Support Pivot	R Main Wheel Bearings	L Wing Pivots

# TROUBLE SHOOTING

The following table lists problems, causes, and solutions that you may encounter. If you encounter a problem that is difficult to solve even after reading

through this table, please call your local Alloway dealer. When calling, please have this manual and your unit's serial number ready.

<b>PROBLEM</b>	<b>CAUSE</b>	<b>SOLUTION</b>
Baskets skidding	Mud buildup	Remove mud Change speeds
Plugging	Too wet	Wait until dry
Leaving wheel tracks	Not enough down pressure	Add down pressure to small hydraulic cylinders
End basket flips	Tight turns	Flip U-pin to mount from botom
Hard to pull	Adjustment	Raise front tine rack (Reduce digging depth)

# ASSEMBLY



## WARNING

- Do not allow bystanders in the area when operating, attaching, removing, assembling, or servicing equipment.



## CAUTION

- Always wear relatively tight and belted clothing to avoid entanglement in moving parts. Wear sturdy, rough-soled work shoes and protective equipment for eyes, hair, hands, hearing, and head; and respirator or filter mask where appropriate.



## WARNING

- Keep hand and body away from pressurized lines. Use paper or cardboard, no hands or other body parts to check for leaks. Wear safety goggles. Hydraulic fluid under pressure can easily penetrate skin and will cause serious injury or death.

- Make sure that all operating and service personnel know that if hydraulic fluid penetrates skin, it must be surgically removed as soon as possible by a doctor familiar with this form of injury or gangrene, serious injury, or death will result. **CONTACT A PHYSICIAN IMMEDIATELY IF FLUID ENTERS SKIN OR EYES. DO NOT DELAY.**

- Check that all hardware is properly installed. Always tighten to torque chart specifications unless instructed otherwise in this manual.





# PARTS INDEX

## SEEDBETTER

SEEDBETTER COMPONENTS.....	34
TOOLBAR COMPONENTS.....	35
CENTER FRAME COMPONENTS.....	36-37
REAR JACK & WING SUPPORT ASM COMPONENTS.....	38
CABLE SHEAVE MOUNT COMPONENTS.....	39
LOCK AND SELECTOR VALVE COMPONENTS.....	40
WING LATCH COMPONENTS .....	41
CRUMBLER ASSEMBLY - WIDE.....	42
H-FRAME COMPONENTS.....	43
HARROW (16 - 4) COMPONENTS.....	44
CRUMBLER BASKET COMPONENTS.....	45
MAIN STRUT COMPONENTS.....	46
WING STRUT COMPONENTS.....	47
CRUMBLER BASKET PLUMBING COMPONENTS .....	48
OUTSIDE WHEEL PLUMBING COMPONENTS .....	49
TOOLBAR LIFT PLUMBING COMPONENTS .....	50-51
CENTER WHEEL PLUMBING COMPONENTS .....	52
HUB & SPINDLE COMPONENTS .....	53
LIGHT KIT COMPONENTS .....	54

# SEEDBETTER COMPONENTS

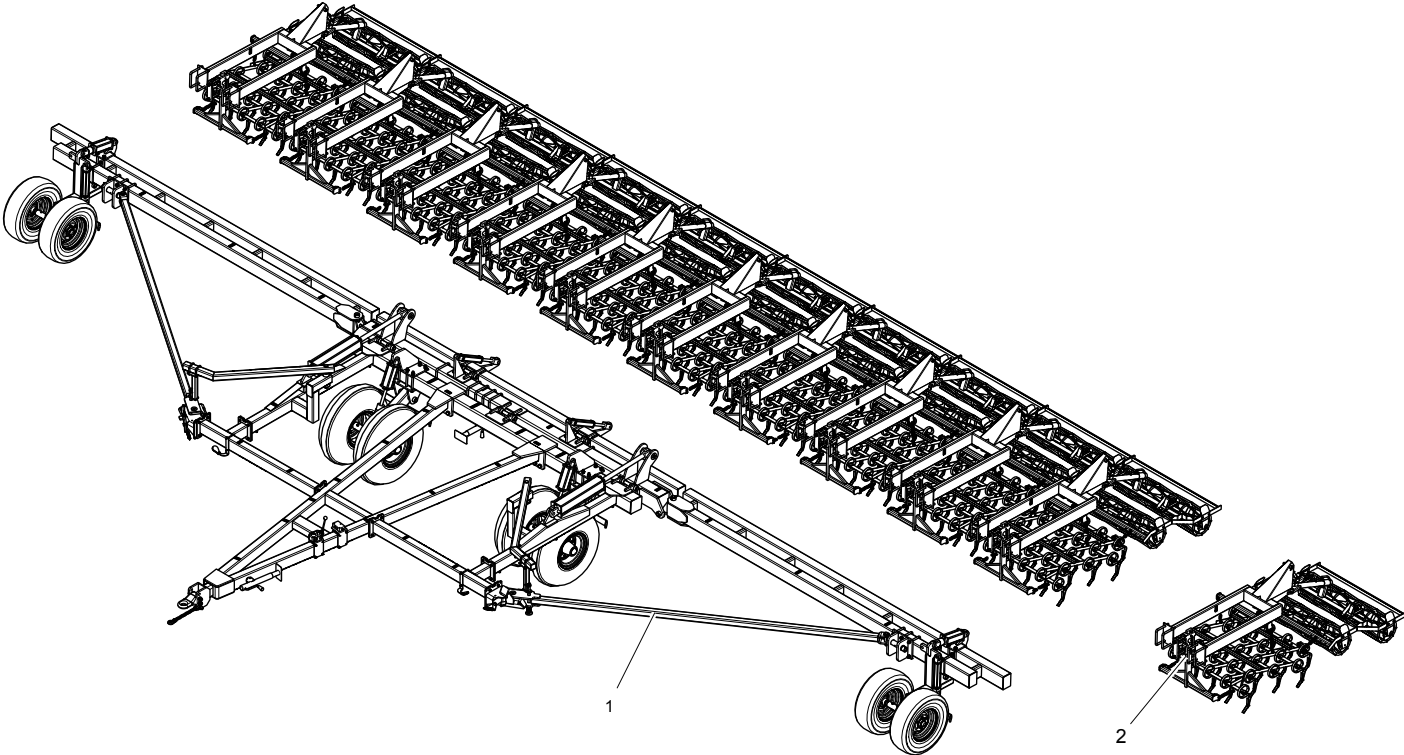

ITEM NO.	PART NUMBER	PAGE NUMBER	DESCRIPTION
1	200-1-3836 200-1-3837 200-1-3838	34	45' TOOLBAR ASSEMBLY 52' TOOLBAR ASSEMBLY 62' TOOLBAR ASSEMBLY
2	200-2-2275 200-2-2358	42	SEEDBETTER CRUMBLER ASSEMBLY SEEDBETTER CRUMBLER ASSEMBLY (WIDE)



# TOOLBAR COMPONENTS

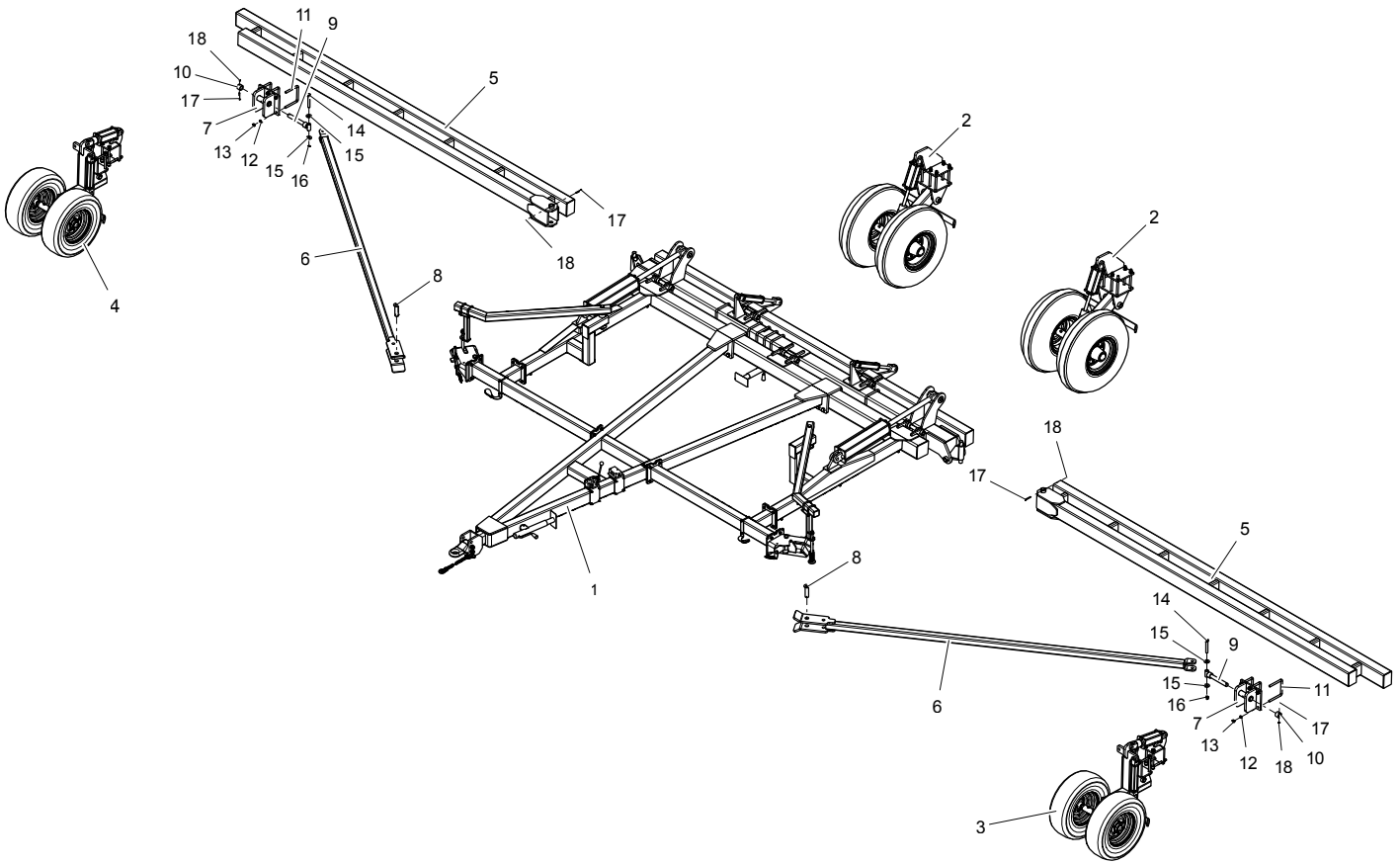

ITEM NO.	PART NUMBER	DESCRIPTION	QTY.
1	SEE PAGE: 36	ASSEMBLY, CENTER FRAME	1
2	SEE PAGE: 46	ASSEMBLY, MAIN STRUT	1
3	SEE PAGE: 47	ASSEMBLY, WING WHEEL ADJ LH	1
4	SEE PAGE: 47	ASSEMBLY, WING WHEEL ADJ RH	1
5	200-2-2345	WELDMENT, 45' WING	2
	200-2-2272	WELDMENT, 52' WING	
	200-2-2359	WELDMENT, 62' WING	
6	200-2-2389	WELDMENT, WING SUPPORT TUBE	2
7	200-2-2246	ASSEMBLY, WING SUPPORT PIVOT	2
8	200-2-2280	WELDMENT, WING SUPPORT PIN	2
9	200-2-2249	WELDMENT, WING SUPPORT LINKAGE	2
10	505-3-0555	BUSHING, 1-1/2 W/ HOLE	2
11	200-3-0477	U-BOLT, 3/4 NC X 7 X 7	6
12	900-11017	WASHER, LOCK 3/4	12
13	900-06015	NUT, HEX HEAD 3/4 NC	12
14	900-01481	BOLT, HEX HEAD 7/8 NC X 6, GR5 ZP	2
15	900-11039	WASHER, FLAT 7/8	
16	900-06017	NUT, TOP LOCK 7/8 NC	2
17	900-01125	BOLT, HEX HEAD 3/8 NC X 3, GR5 ZP	4
18	900-06500	NUT, TOP LOCK 3/8 NC	4

# CENTER FRAME COMPONENTS

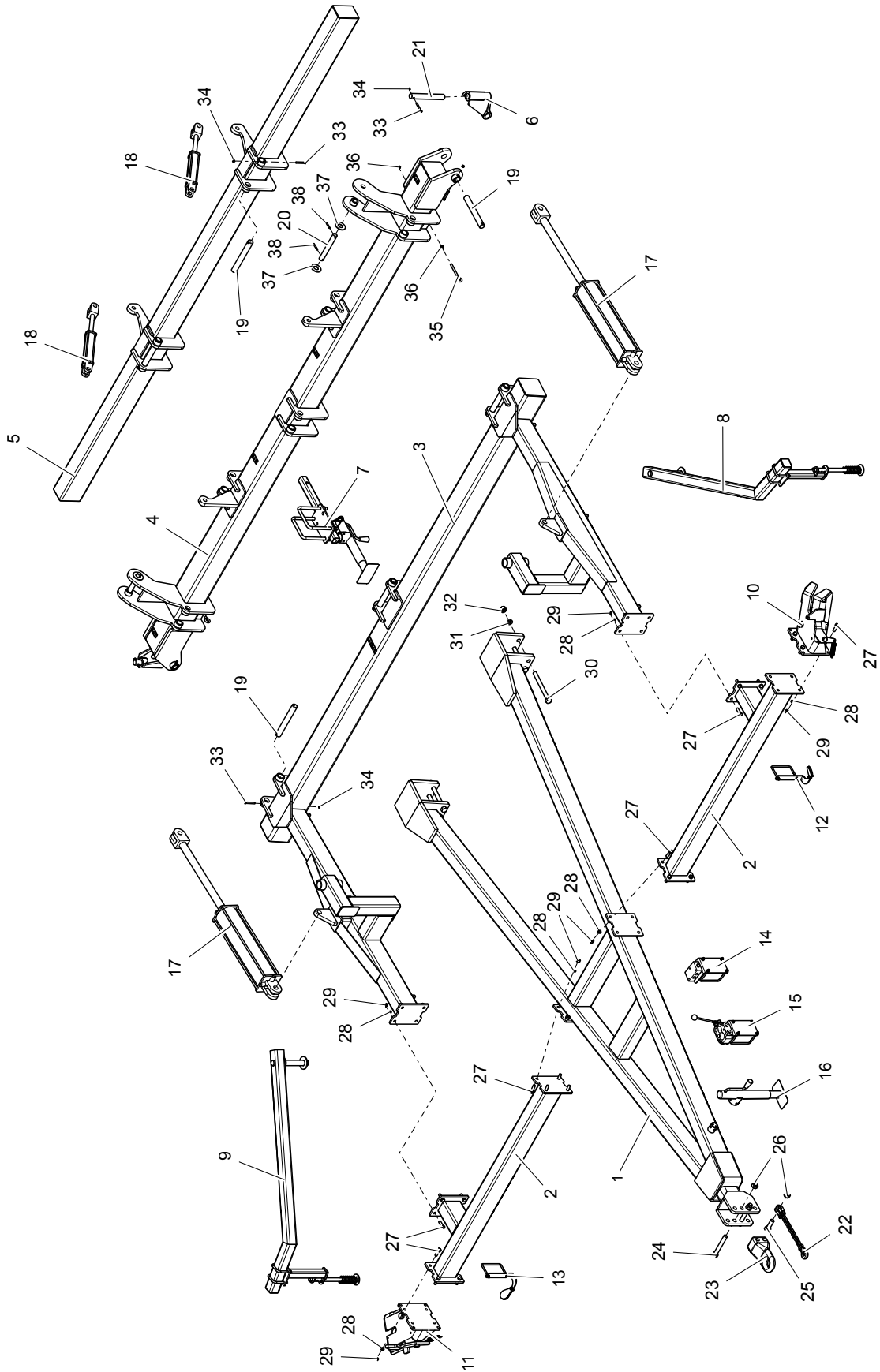

## CENTER FRAME COMPONENTS

ITEM NO.	PART NUMBER	DESCRIPTION	QTY.
1	200-2-2241	WELDMENT, HITCH FRAME	1
2	200-2-2285	WELDMENT, SIDE HITCH TUBE	2
3	200-2-2239	WELDMENT, CENTER FRONT BAR	1
4	200-2-2238	WELDMENT, CENTER MID BAR	1
5	200-2-2253	WELDMENT, CENTER REAR BAR	1
6	200-2-2236	WELDMENT, WING PIVOT LINKAGE	2
7	SEE PAGE: 38	ASSEMBLY, REAR JACK MOUNT	1
8	SEE PAGE: 38	ASSEMBLY, WING SUPPORT ARM (LH)	2
9	SEE PAGE: 38	ASSEMBLY, WING SUPPORT ARM (RH)	2
10	SEE PAGE: 41	ASSEMBLY, WING LATCH (LH)	1
11	SEE PAGE: 41	ASSEMBLY, WING LATCH (RH)	1
12	SEE PAGE: 39	ASSEMBLY, CABLE SHEAVE MOUNT (LH)	1
13	SEE PAGE: 39	ASSEMBLY, CABLE SHEAVE MOUNT (RH)	1
14	SEE PAGE: 40	ASSEMBLY, LOCK VALVE MOUNT	1
15	SEE PAGE: 40	ASSEMBLY, SELECTOR VALVE MOUNT	1
16	905-23018	JACK, 5000 LB	1
17	905-21442	CYLINDER, 5 X 24 BLACK	2
18	905-21390	CYLINDER, 2 X 10 BLACK	2
19	200-3-3431	PIN, PIVOT	8
20	200-3-4426	PIN, MAIN LIFT	2
21	200-3-4396	PIN, WING HINGE	2
22	905-07123	CHAIN, SAFETY TOW (21,000 LB)	1
23	505-3-0831	HITCH, CAT-3	1
24	900-02930	BOLT, HEX HEAD, 1 NC X 7, GR5 ZP	2
25	900-01519	BOLT, HEX HEAD, 1 NC X 3, GR5 ZP	1
26	900-06514	NUT, TOP LOCK, 1 NC	3
27	900-01345	BOLT, HEX HEAD, 5/8 NC X 2, GR5 ZP	24
28	900-11015	WASHER, LOCK, 5/8	24
29	900-06013	NUT, HEX HEAD, 5/8 NC	24
30	900-01553	BOLT, HEX HEAD, 1 NC X 10-1/2, GR5 ZP	6
31	900-11021	WASHER, LOCK, 1	6
32	900-06019	NUT, HEX HEAD, 1 NC	6
33	900-01125	BOLT, HEX HEAD, 3/8 NC X 3, GR5 ZP	7
34	900-06500	NUT, TOP LOCK, 3/8 NC	7
35	100-3-0148	BOLT, EYE, 1/2 NC	2
36	900-06143	NUT, SPIRALOCK FLANGE, 1/2 NC	4
37	900-11042	WASHER, FLAT, 1-1/4	4
38	900-29208	PIN, ROLL, 5/16 X 2-1/4	4
39	200-3-4428	WING LOCK CABLE, 3/16" x 12FT (NOT SHOWN)	2

## REAR JACK & WING SUPPORT ARM COMPONENTS

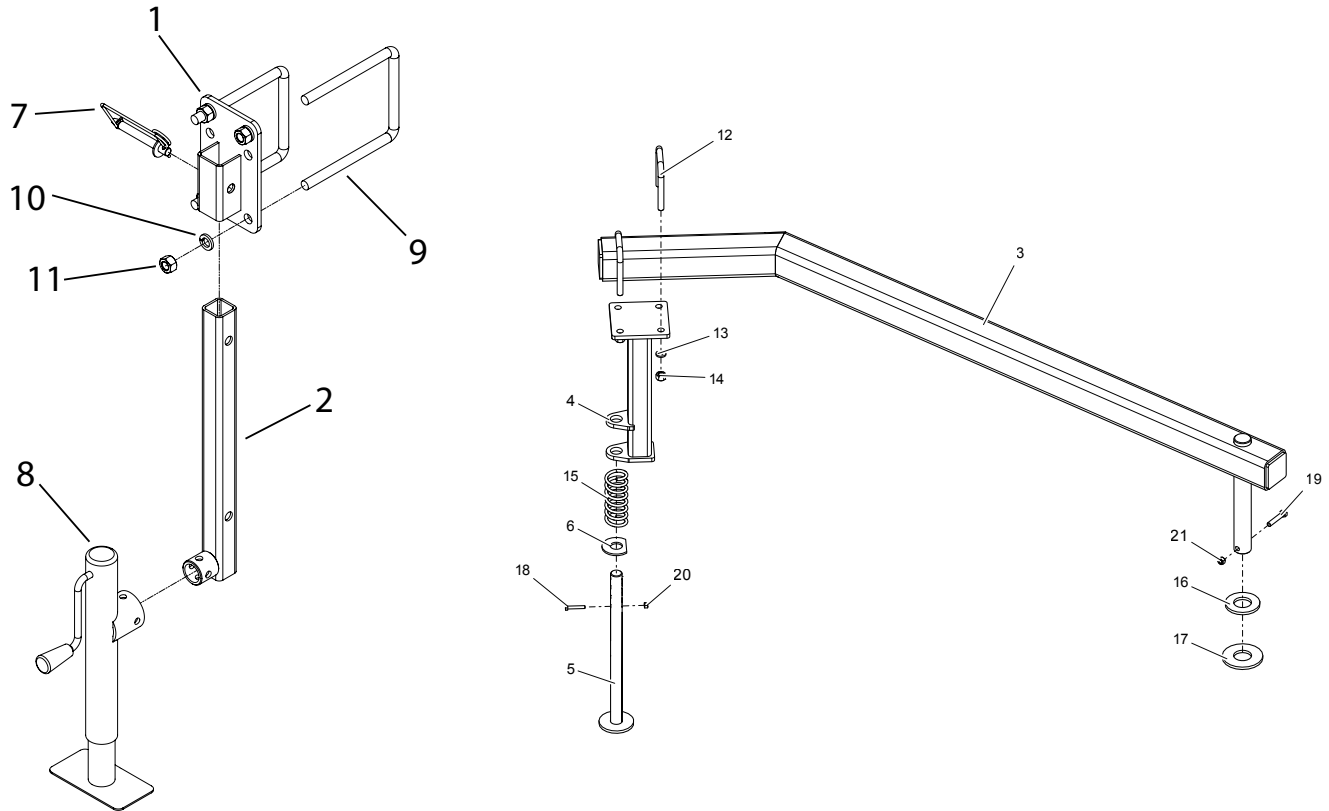

ITEM NO.	PART NUMBER	DESCRIPTION	QTY.
1	200-2-2307	WELDMENT, JACK MOUNTING PLATE	1
2	200-2-2306	WELDMENT, ADJUSTMENT TUBE	1
3	200-2-2378	WELDMENT, WING SUPPORT ARM (LH)	1
	200-2-2375	WELDMENT, WING SUPPORT ARM (RH)	
4	200-2-2379	WELDMENT, PIVOT BRACKET	1
5	200-2-2380	WELDMENT, SUPPORT ARM SPRING PIN	1
6	200-3-4619	WASHER	1
7	900-42054	PIN, SNAP LOCK CLEVIS, 5/8 X 4	1
8	905-23018	JACK, 5000 LB	1
9	200-3-0345	U-BOLT, 3/4 NC X 7 X 9.13	2
10	900-11017	WASHER, LOCK, 3/4	4
11	900-06015	NUT, HEX HEAD, 3/4 NC	6
12	500-3-1578	U-BOLT, 1/2 NC X 3 X 4	6
13	900-11013	WASHER, LOCK, 1/2	12
14	900-06009	NUT, HEX HEAD, 1/2 NC	12
15	905-14005	SPRING	1
16	901-01240	OILITE BUSHING	1
17	900-11044	WASHER, FLAT 1-1/2	1
18	900-01013	BOLT, 1/4 NC x 1-1/2	1
19	900-01117	BOLT, 3/8 NC x 2	1
20	900-06496	NUT, TOP LOCK, 1/4 NC	1
21	900-06500	NUT, TOP LOCK, 3/8 NC	1

## CABLE SHEAVE MOUNT COMPONENTS

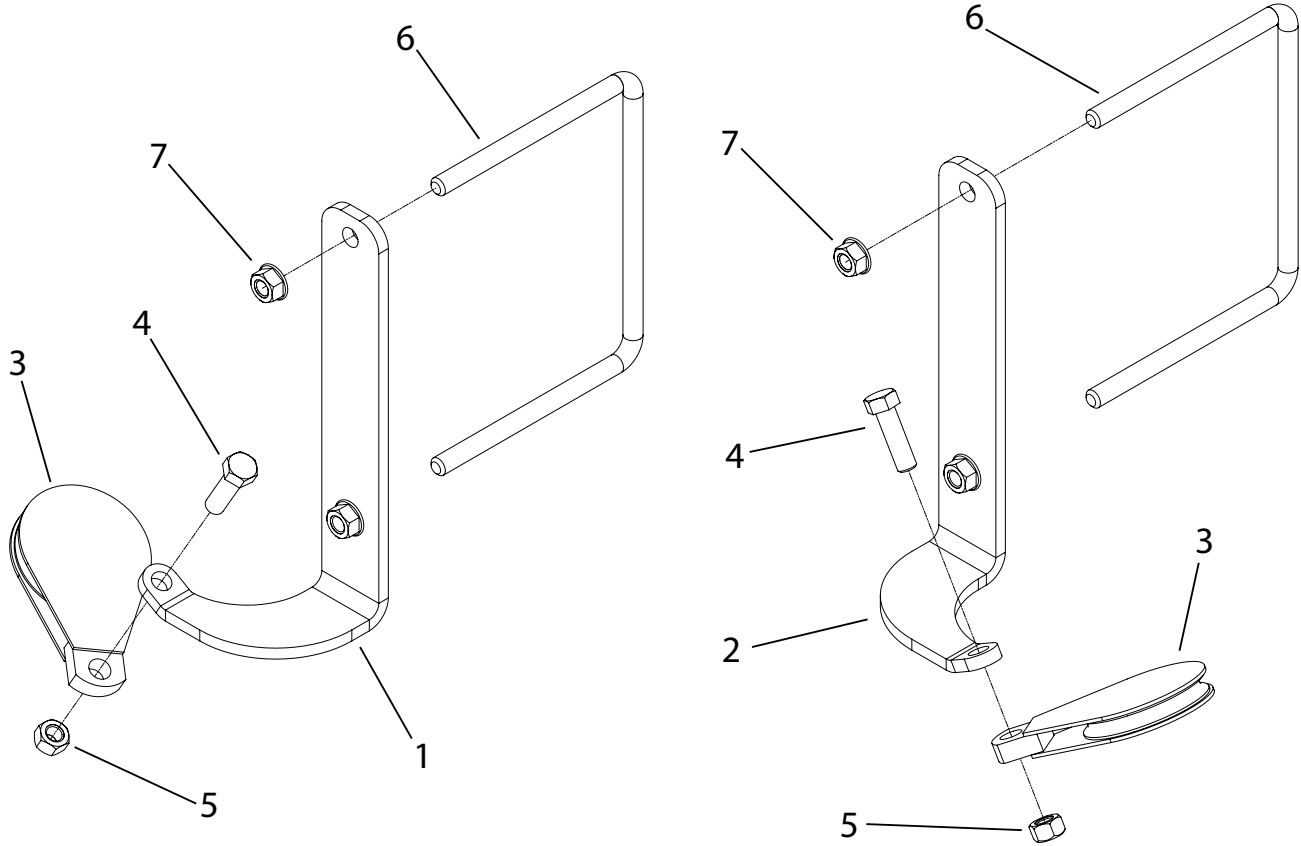

ITEM NO.	PART NUMBER	DESCRIPTION	QTY.
1	200-3-4459	CABLE SHEAVE MOUNT (RH)	1
2	200-3-4546	CABLE SHEAVE MOUNT (LH)	1
3	905-07129	FIXED EYE BLOCK	2
4	900-01111	BOLT, HEX HEAD, 3/8 NC X 1-1/4, GR5 ZP	2
5	900-06500	NUT, TOP LOCK, 3/8 NC	2
6	900-35000	U-BOLT, 3/8 NC X 6 X 5	2
7	900-06139	NUT, SERRATED FLANGE, 3/8 NC	2

## LOCK & SELECTOR VALVE COMPONENTS

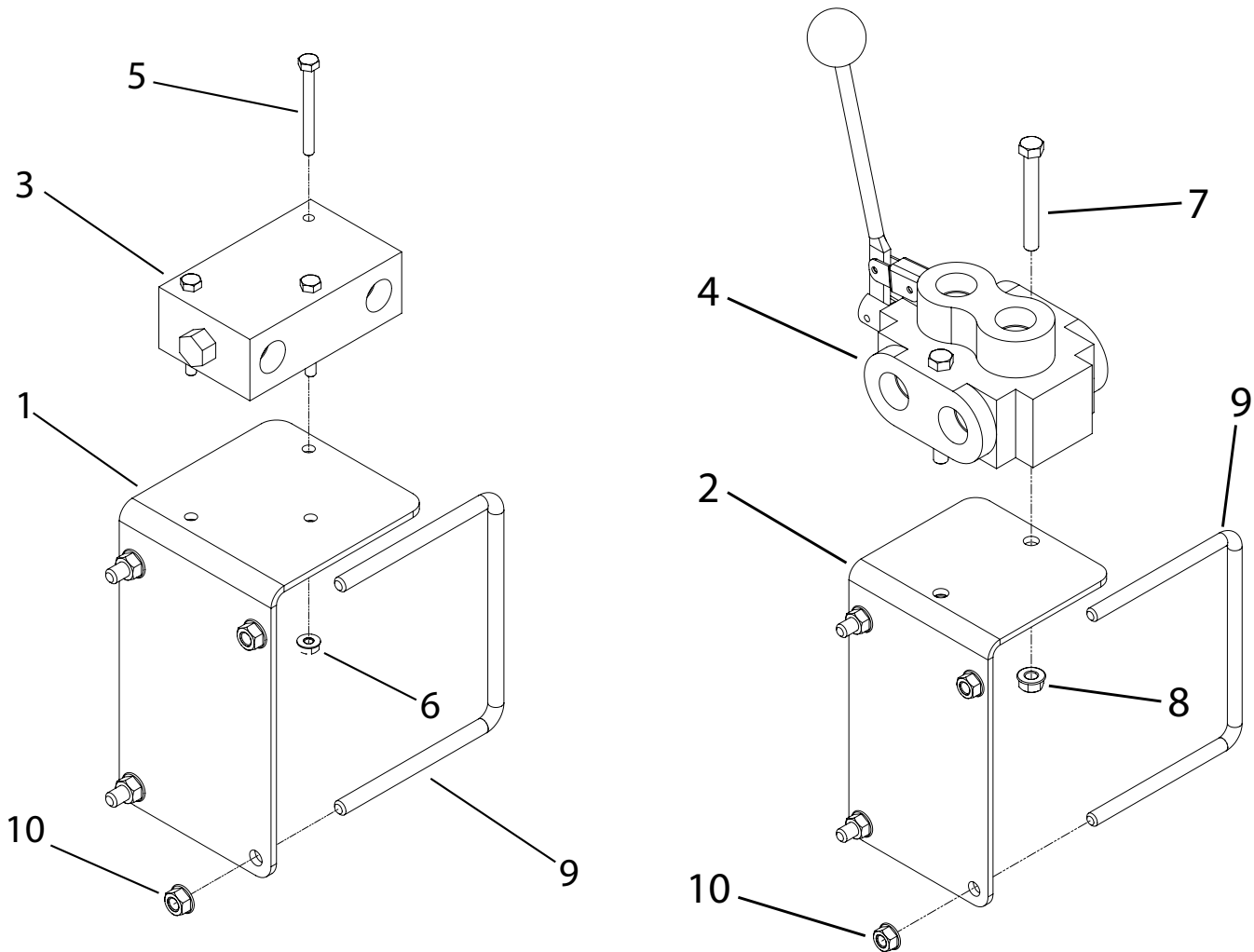

ITEM NO.	PART NUMBER	DESCRIPTION	QTY.
1	200-3-4562	LOCK VALVE PLATE	1
2	200-3-4549	SELECTOR VALVE PLATE	1
3	905-03260	LOCK VALVE, 1/2 MP	1
4	905-03252	DOUBLE SELECTOR VALVE, 1/2 MP	1
5	900-01021	BOLT, HEX HEAD, 1/2 NC X 2-1/2	3
6	900-06135	NUT, SERRATED FLANGE, 1/2 NC	3
7	900-01125	BOLT, HEX HEAD, 3/8 NC X 3	2
8	900-06139	NUT, SERRATED FLANGE, 3/8 NC	2
9	900-35000	U-BOLT, 3/8 NC X 6 X 5	4
10	900-06139	NUT, SERRATED FLANGE, 3/8 NC	8

# WING LATCH COMPONENTS

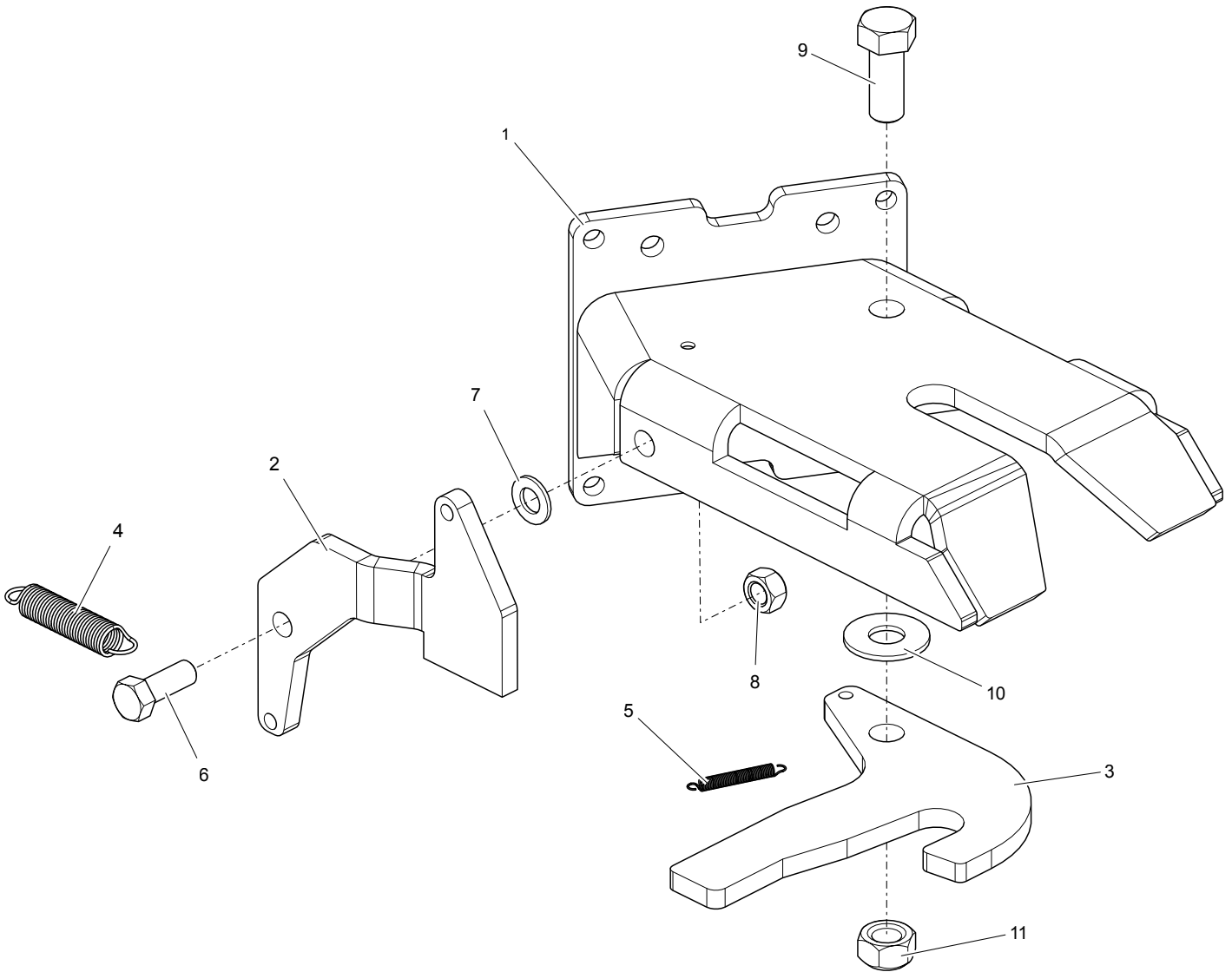

ITEM NO.	PART NUMBER	DESCRIPTION	QTY.
1	200-2-2362	WELDMENT, WING LATCH (LH)	1
	200-2-2373	WELDMENT, WING LATCH (RH)	
2	200-3-4600	LOCK BAR (LH)	1
	200-3-4604	LOCK BAR (RH)	
3	200-2-2363	WELDMENT, INNER LOCK (LH)	1
	200-2-2388	WELDMENT, INNER LOCK (RH)	
4	200-3-4136	SPRING, EXTENSION (1.0 OD, 5.00 LENGTH, 0.105 WIRE DIA)	1
5	200-3-4427	SPRING, EXTENSION (0.5 OD, 3.44 LENGTH, 0.054 WIRE DIA)	1
6	900-01403	BOLT, HEX HEAD 3/4 NC X 2, GR5 ZP	2
7	900-11038	WASHER, FLAT 3/4	1
8	900-06510	NUT, LOCK 3/4 NC	1
9	900-01515	BOLT, HEX HEAD 1 NC X 2-1/2, GR5 ZP	1
10	900-11040	WASHER, FLAT 1	1
11	900-06514	NUT, LOCK 1 NC	1

# SEEDBETTER CRUMBLER ASSEMBLY - WIDE

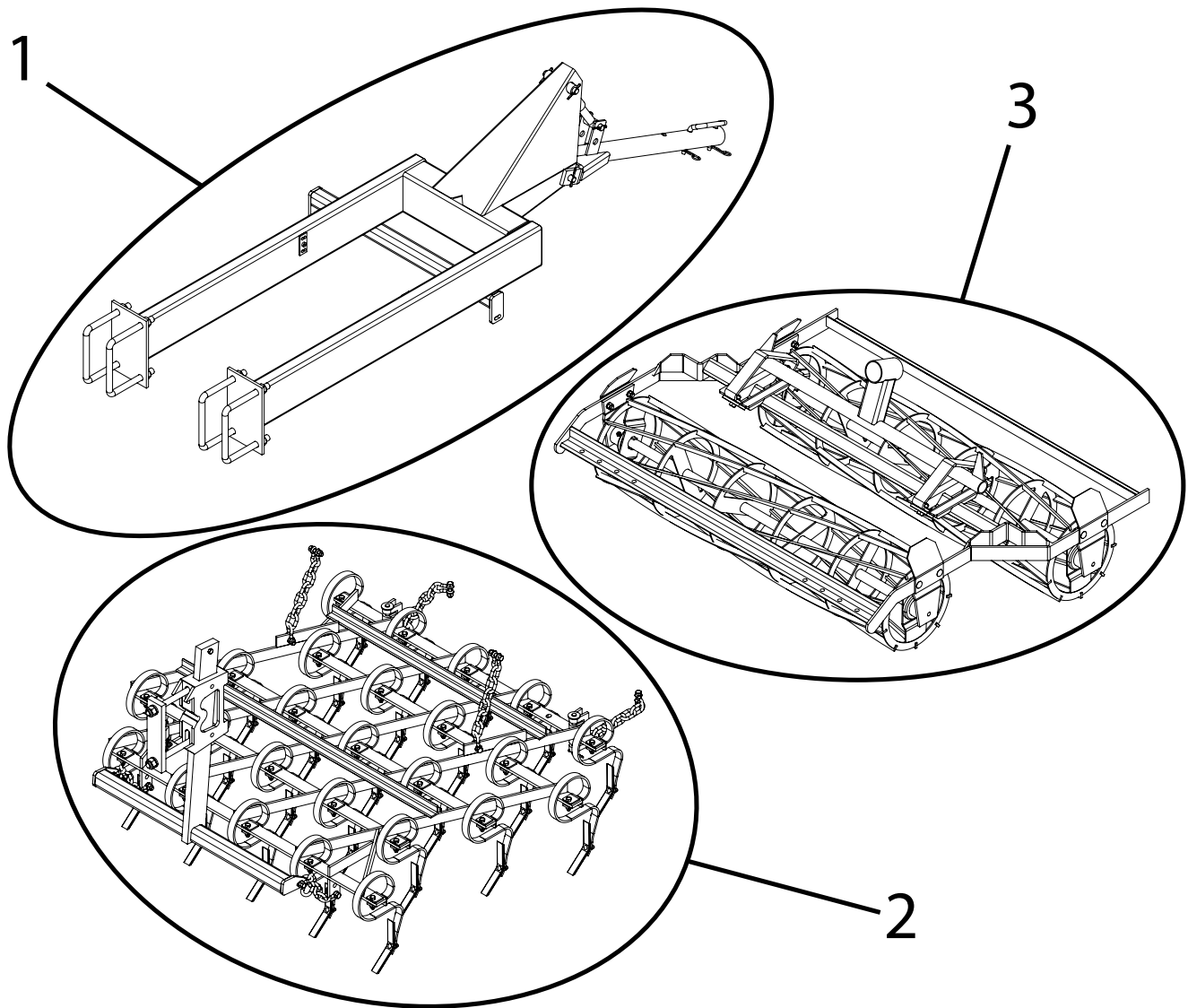

ITEM NO.	PAGE NUMBER	DESCRIPTION
1	43	H - FRAME ASSEMBLY
2	44	HARROW - 16-4 ASSEMBLY
3	45	CRUMBLER BASKET ASSEMBLY



## H-FRAME COMPONENTS

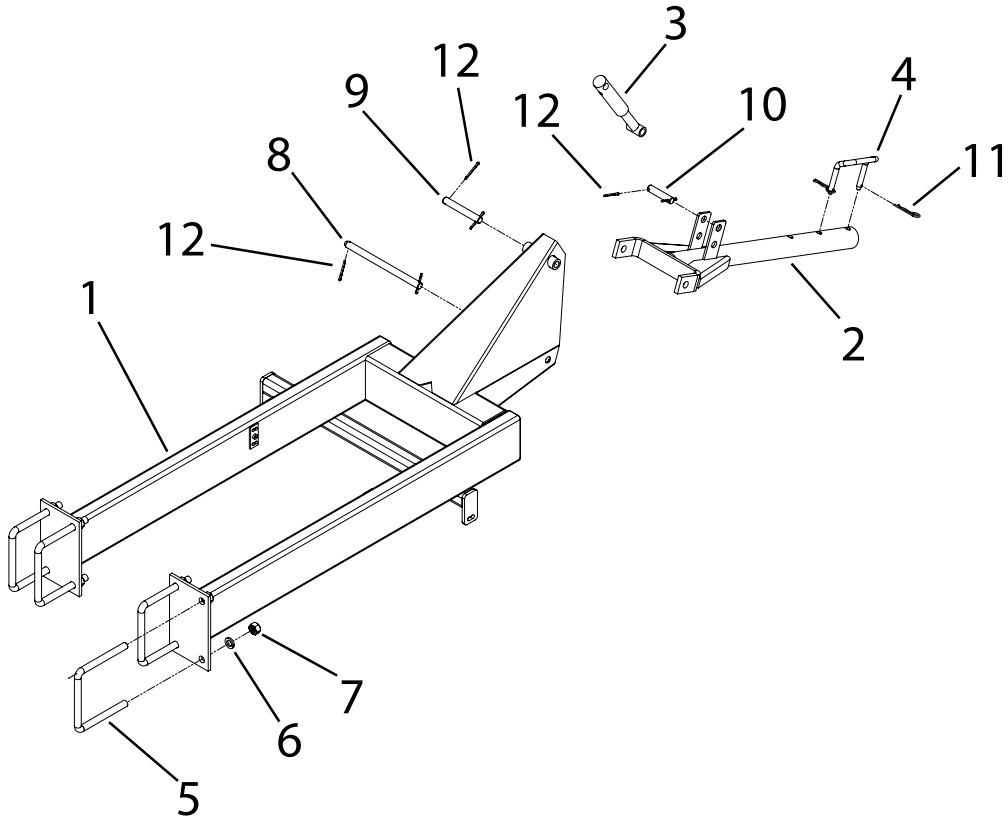

ITEM NO.	PART NUMBER	DESCRIPTION	QTY.
1	200-2-2274	WELDMENT, H-FRAME	1
2	210-2-0135	WELDMENT, DOWN PRESS ARM	1
3	210-3-0577	CYLINDER, CRUMBLER	1
4	210-3-0264	U-PIN, CRUMBLER	1
5	200-3-0477	U-BOLT, 3/4 NC X 7 X 7 LG	4
6	900-11017	WASHER, LOCK 3/4 ZP	8
7	900-06015	NUT, HEX HEAD, 3/4 NC, ZP	8
8	210-3-0261	PIN, DOWN PRESSURE ARM	1
9	210-3-0341	PIN, CRUMBLER CYLINDER	1
10	210-3-0262	PIN, CYLINDER	1
11	900-25005	PIN, HAIR CLIP, 5/32 (#9)	2
12	900-23043	PIN, COTTER, 3/16 X 1-1/2	6

## HARROW (16 - 4) COMPONENTS

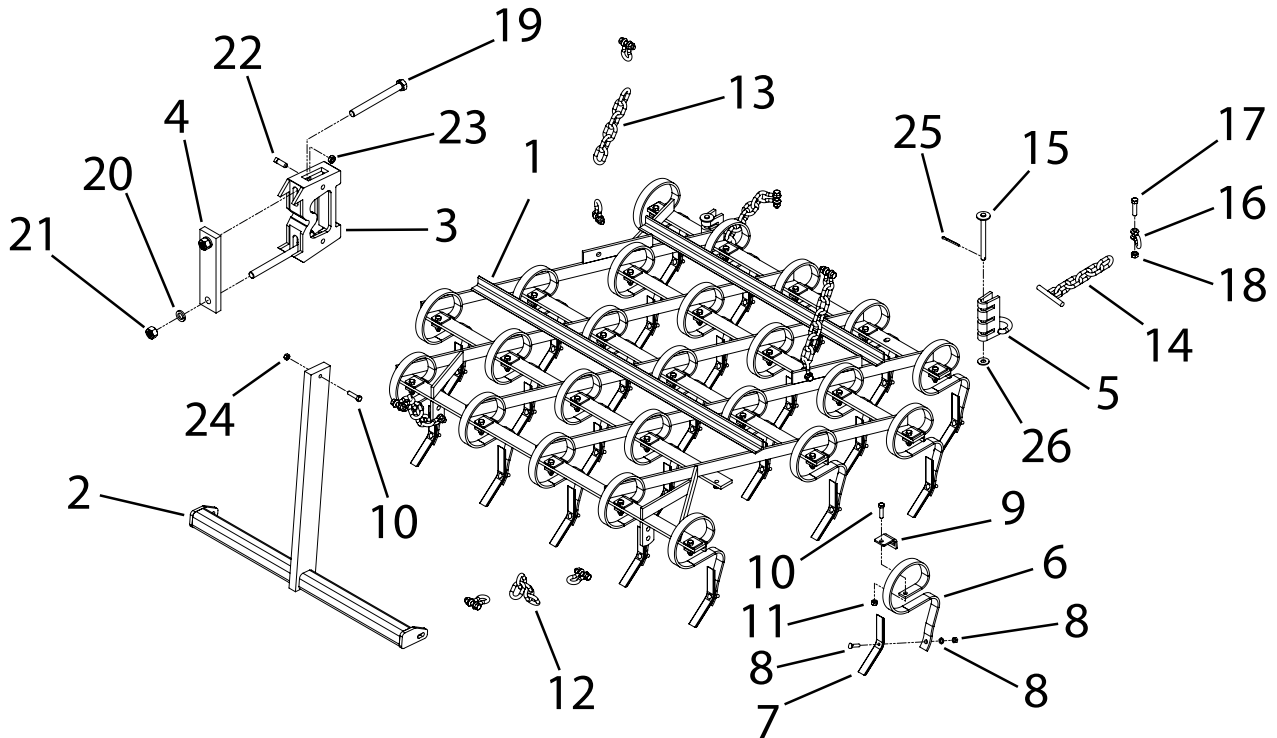

ITEM NO.	PART NUMBER	DESCRIPTION	QTY.
1	210-2-0314	WELDMENT, HARROW FRAME	1
	210-2-5036	WELDMENT, HARROW FRAME (WIDE)	
2	200-2-2270	PULL T-BAR	1
3	200-3-1022	CAST CLAMP, LARGE, 7" CUT	1
4	200-3-1024	STRAP, 7 X 7 BOLTING	1
5	210-3-0442	PULL BRACKET	2
6	905-10100	S-TINE ASSEMBLY, 25 X 8 W/ POINT (INCLUDES #7 & #8)	25
7	905-10102	- REVERSIBLE POINT	25
8	200-1-2859	- BOLT KIT, POINT	25
9	205-3-0110	HARROW TINE CLAMP	25
10	900-01113	BOLT, HEX HEAD, 3/8 NC X 1-1/2, GR 5 ZP	26
11	900-06005	NUT, HEX HEAD 3/8 NC	25
12	210-3-0499	CRUMBLER PULL CHAIN (5 LINKS)	2
13	200-3-4432	CRUMBLER PULL CHAIN (7 LINKS)	2
14	205-2-0031	PULL CHAIN	2
15	200-2-2264	PIN WELD - HARROW	2
16	210-3-0327	CLEVIS	10
17	900-01177	BOLT, HEX HEAD 7/16 NC X 1-3/4, GR 5 ZP	10
18	900-06502	NUT, TOP LOCK 7/16 NC	10
19	900-01433	BOLT, HEX HEAD 3/4 NC X 7-1/2, GR 5 ZP	2
20	900-11017	WASHER, LOCK 3/4	2
21	900-06015	NUT, HEX HEAD 3/4 NC	2
22	900-16063	SCREW, SET, SQUARE HEAD 1/2 NC X 1-1/4	2
23	900-06276	NUT, JAM 1/2 NC	2
24	900-06500	NUT, TOP LOCK 3/8 NC	1
25	900-23043	PIN, COTTER 3/16 X 1-1/2	2
26	900-11035	WASHER, FLAT 1/2	

## CRUMBLER BASKET COMPONENTS

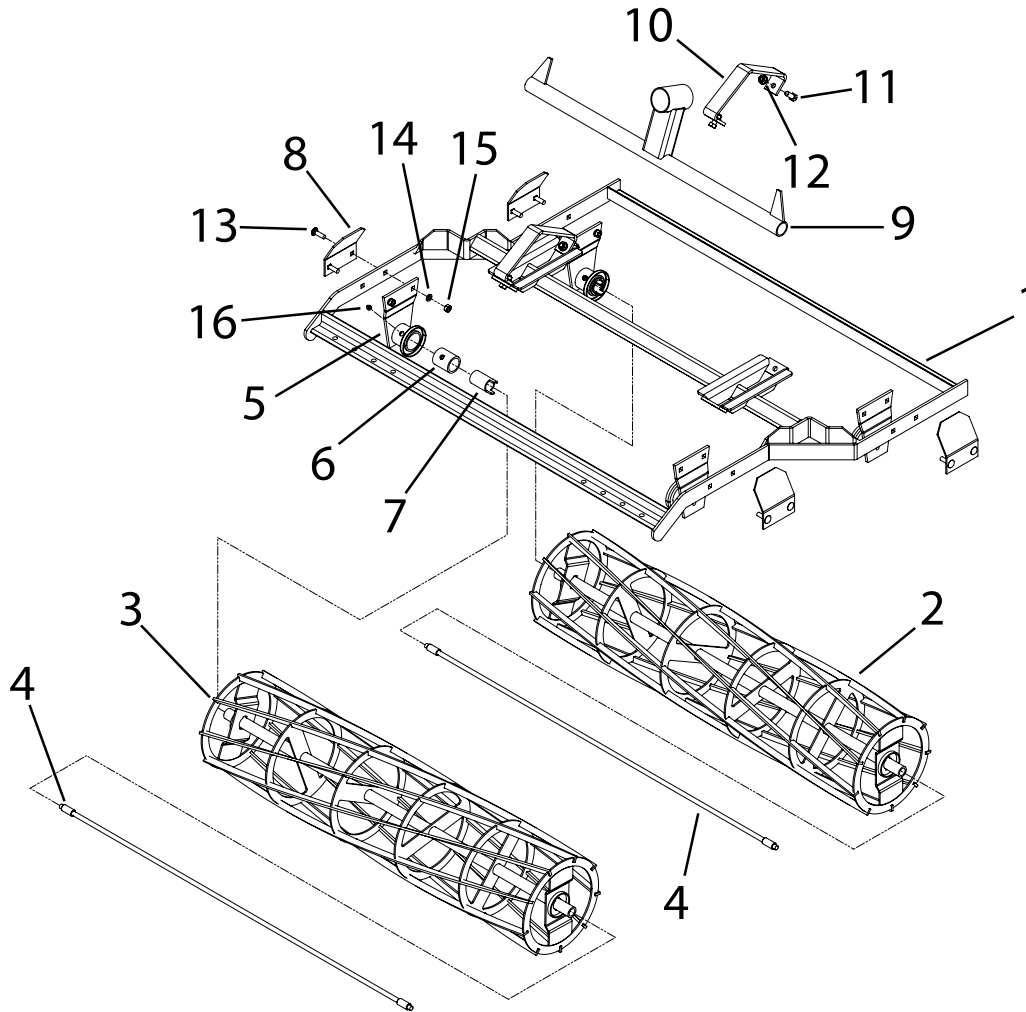

ITEM NO.	PART NUMBER	DESCRIPTION	QTY.
1	210-2-0018	WELDMENT, FRAME	1
	210-2-0023	WELDMENT, FRAME (WIDE)	
2	210-2-0111	WELDMENT, BASKET, RH	1
	210-2-0113	WELDMENT, BASKET, RH (WIDE)	
3	210-2-0112	WELDMENT, BASKET, LH	1
	210-2-0114	WELDMENT, BASKET, LH (WIDE)	
4	210-2-0133	WELDMENT, REINFORCING ROD	2
	210-2-0134	WELDMENT, REINFORCING ROD (WIDE)	
5	210-2-0026	WELDMENT, BEARING BRACKET	4
6	210-3-0617	BUSHING, RYERTEX	4
7	210-3-0223	BUSHING, STEEL	4
8	210-3-0328	DEFLECTOR	4
9	200-2-2276	WELDMENT, DOWN PRESS TEE	1
10	210-3-0263	LIFT STRAP	2
11	900-01223	BOLT, HEX HEAD, 1/2 NC X 1-1/4, GR 5 ZP	4
12	900-06143	NUT, SPIRALOCK FLANGE, 1/2 NC	4
13	900-01726	BOLT, CARRIAGE 7/16 NC X 1-1/2, GR 5 ZP	8
14	900-11012	WASHER, LOCK 7/16	8
15	900-06007	NUT, 7/16 NC	8
16	210-3-0015	ZERK, GREASE	4

## MAIN STRUT COMPONENTS

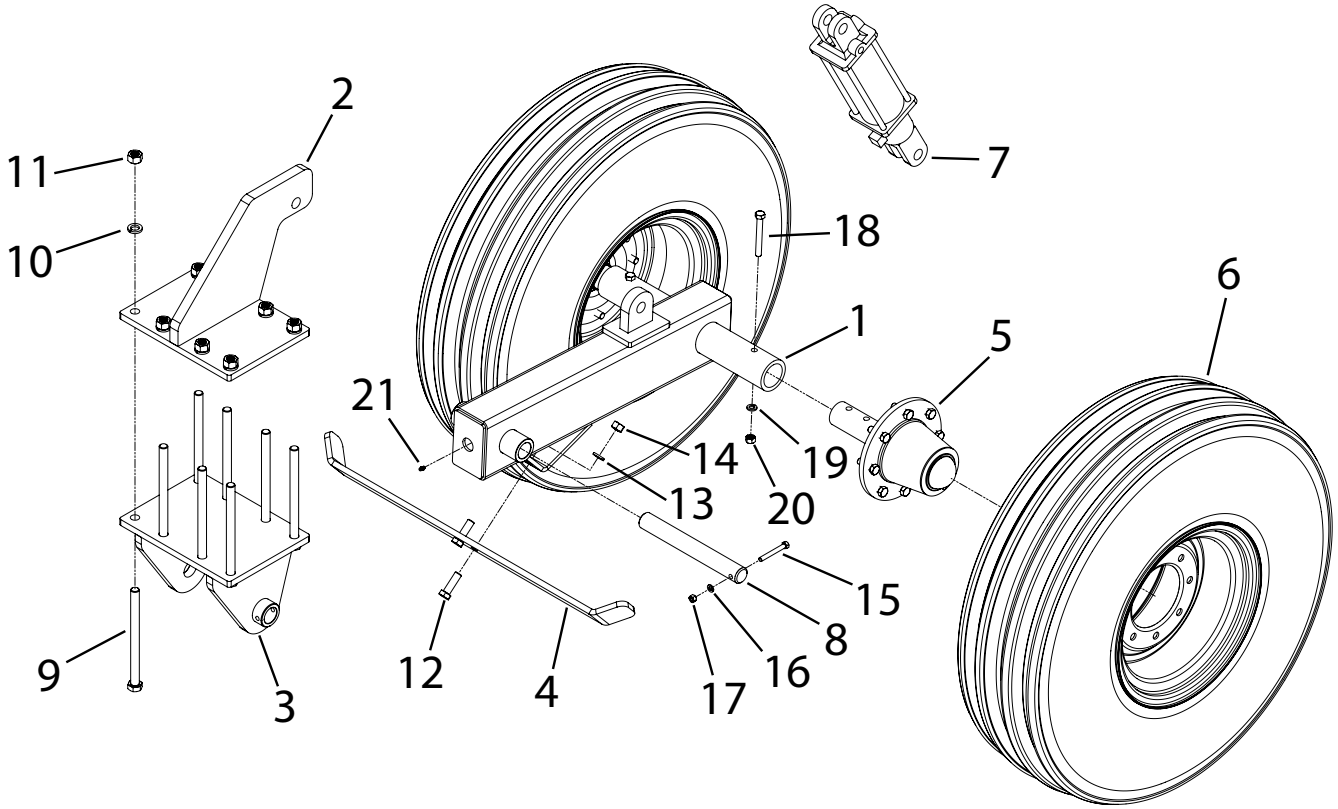

ITEM NO.	PART NUMBER	DESCRIPTION	QTY.
1	200-2-2261	WELDMENT, MAIN STRUT TUBE	1
2	200-2-2260	WELDMENT, MAIN STRUT TOP	1
3	200-2-2258	WELDMENT, MAIN STRUT	1
4	200-3-4437	WHEEL SCRAPER, CENTER	1
5	700-2-0165	HUB & SPINDLE ASSEMBLY, 8-BOLT - (SEE PAGE: 53)	2
6	905-09173	TIRE & RIM ASSEMBLY	2
	905-09146	- RIM, 16 X 10 X 8BOLT	
	905-09175	- TIRE, 11.00 X 16.00 MULTI-RIB, 8 PLY	
7	905-21400	CYLINDER, 3-1/2 X 8 BLACK	1
	700-2-0159	CYLINDER TRANSPORT LOCK	-
8	200-3-4397	PIN, HINGE STRUT	2
9	900-01443	BOLT, HEX HEAD 3/4 NC X 10, GR5 ZP	8
10	900-11017	WASHER, LOCK 3/4	8
11	900-06015	NUT, HEX HEAD 3/4 NC	8
12	900-01345	BOLT, HEX HEAD 5/8 NC X 2, GR5 ZP	2
13	900-11015	WASHER, LOCK 5/8	2
14	900-06013	NUT, HEX HEAD 5/8 NC	2
15	900-01125	BOLT, HEX HEAD 3/8 NC X 3, GR5 ZP	1
16	900-11011	WASHER, LOCK 3/8	1
17	900-06005	NUT, HEX HEAD 3/8 NC	1
18	900-01245	BOLT, HEX HEAD 1/2 NC X 4, GR5 ZP	2
19	900-11013	WASHER, LOCK 1/2	2
20	900-06009	NUT, HEX HEAD 1/2 NC	2
21	905-15024	ZERK, STRAIGHT 1/4" - 28	1

## WING STRUT COMPONENTS

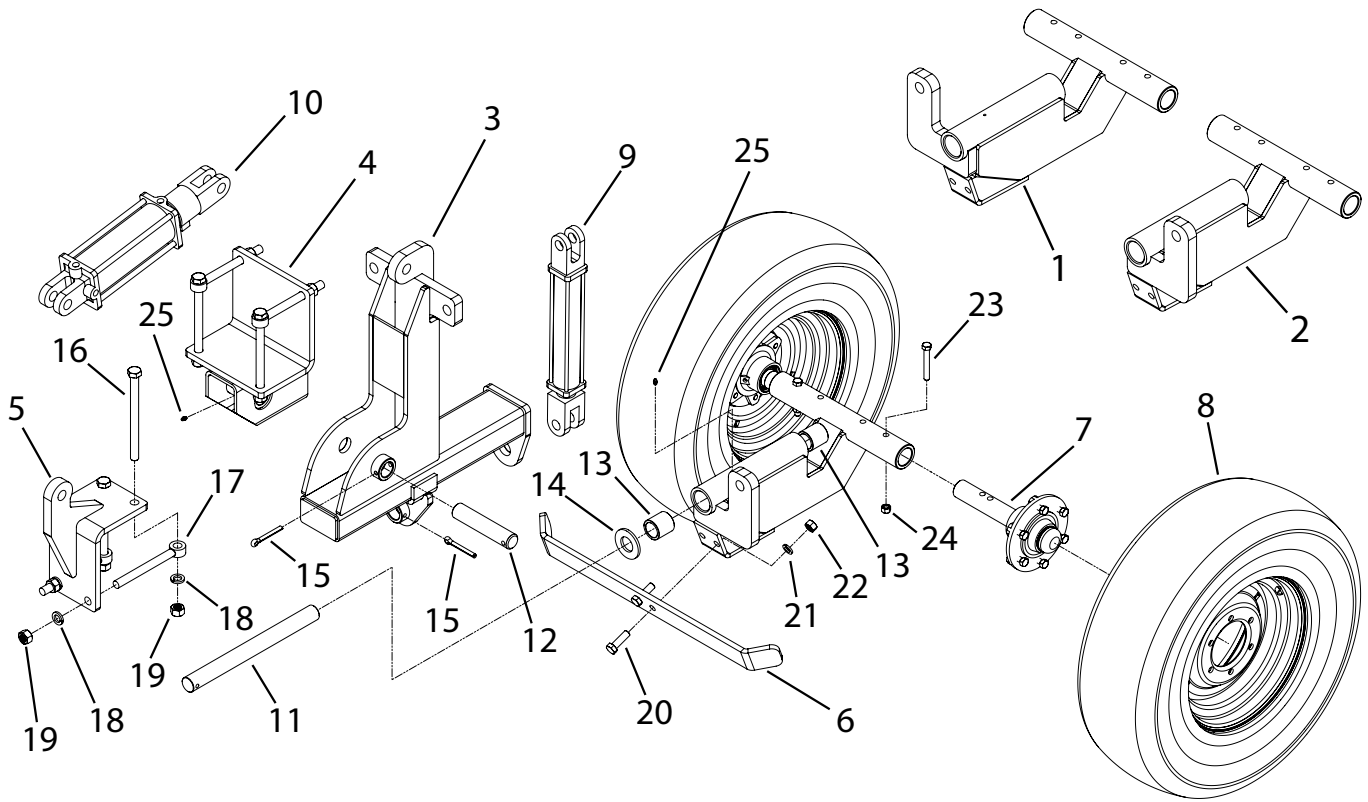

ITEM NO.	PART NUMBER	DESCRIPTION	QTY.
1	200-2-2288	WELDMENT, WING STRUT PIVOT RH	1
2	200-2-2289	WELDMENT, WING STRUT PIVOT LH	1
3	200-2-2317	WELDMENT, WING WHEEL LOWER PIVOT	1
4	200-2-2316	WELDMENT, WING WHEEL MOUNTING PLATE	1
5	200-2-2318	WELDMENT, WING WHEEL CYLINDER EAR	1
6	200-3-4436	WING WHEEL SCRAPER	1
7	200-2-2344	HUB & SPINDLE ASSEMBLY, 6-BOLT - (SEE PAGE: 53)	2
8	905-09177	TIRE & RIM ASSEMBLY	2
	905-09077	- RIM, 15 X 6 X 6 BOLT	
	905-09070	- TIRE, 9.50 X 15.00 IMPLEMENT	
9	905-21390	CYLINDER, 2 X 10 BLACK	1
10	905-21400	CYLINDER, 3-1/2 X 8 BLACK	1
11	500-3-1328	PIN, PIVOT	1
12	200-3-4477	PIN, WING STRUT HINGE	1
13	901-01146	BUSHING, BRONZE	2
14	500-3-0538	SPACER, BUSHING	1
15	900-23084	PIN, COTTER 3/8 X 3-1/2	2
16	900-01441	BOLT, HEX HEAD 3/4 NC X 9-1/2, GR5 ZP	4
17	900-03462	BOLT, EYE 3/4 NC X 8	4
18	900-11017	WASHER, LOCK 3/4	8
19	900-06015	NUT, HEX HEAD 3/4 NC	8
20	900-01345	BOLT, HEX HEAD 5/8 NC X 2, GR5 ZP	2
21	900-11015	WASHER, LOCK 5/8	2
22	900-06013	NUT, HEX HEAD 5/8 NC	2
23	900-01241	BOLT, HEX HEAD 1/2 NC X 3-1/2, GR5 ZP	2
24	900-06504	NUT, TOP LOCK 1/2 NC	2
25	905-15024	ZERK, STRAIGHT 1/4" - 28	2

## CRUMBLER BASKET PLUMBING COMPONENTS

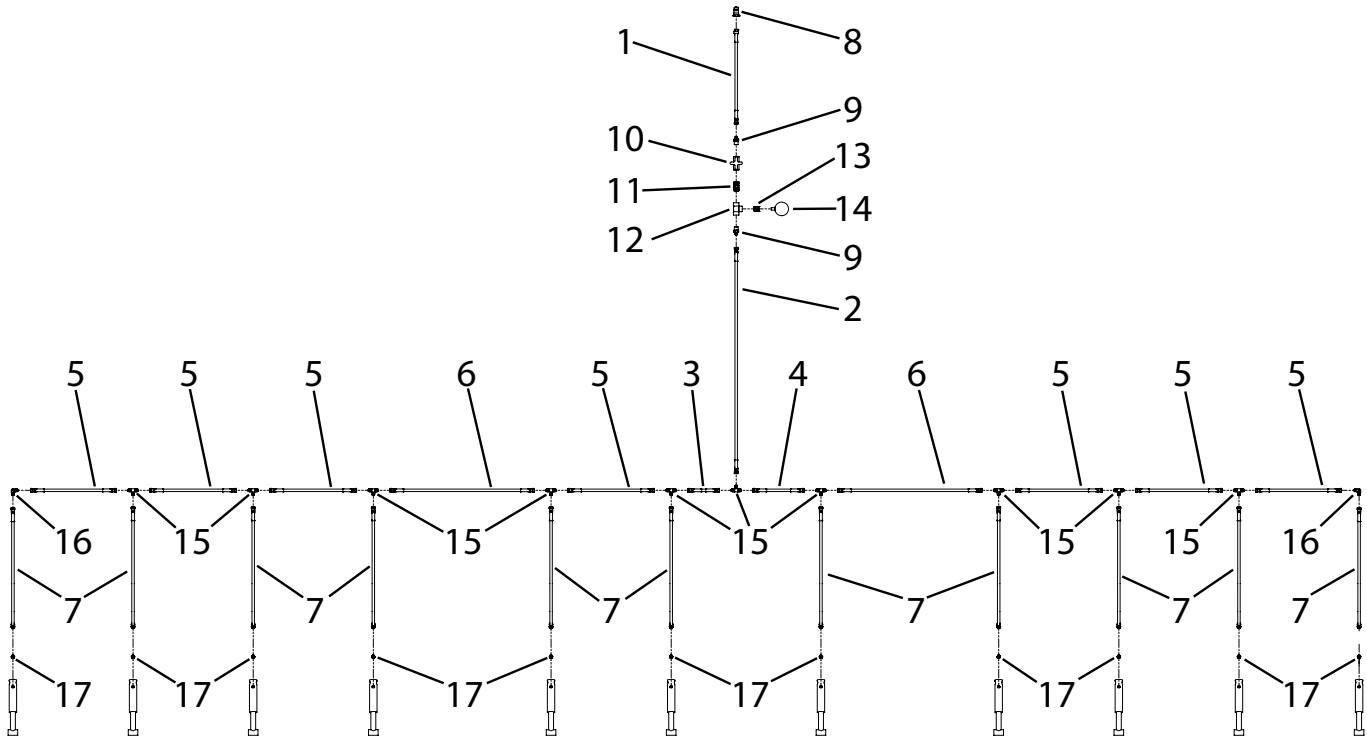

ITEM NO.	PART NUMBER	DESCRIPTION	QTY.
1	905-19243	1/4 HOSE, 8MB x 6FJX	90" LENGTH 1
2	905-19244	1/4 HOSE, 6FJX x 6FJX	167" LENGTH 1
3	905-19245	1/4 HOSE, 6FJX x 6FJX	20" LENGTH 1
4	905-19246	1/4 HOSE, 6FJX x 6FJX	35" LENGTH 1
5	905-19247	1/4 HOSE, 6FJX x 6FJX	55" LENGTH 7
6	905-19254	1/4 HOSE, 6FJX x 6FJX	90" LENGTH 2
7	905-19248	1/4 HOSE, 6FJX x 6FJX	74" LENGTH 11
8	905-19126	QUICK COUPLER, MALE 8FB	1
9	905-03110	ADAPTER, STRAIGHT, 8MP X 6MJ	2
10	905-03066	NEEDLE VALVE, 8FP (5000 PSI)	1
11	905-01228	ADAPTER, NIPPLE, 8MP	1
12	905-03166	ADAPTER, TEE, 8FP	1
13	905-03255	ADAPTER, REDUCER, 8MP X 4FP	1
14	905-03072	PRESSURE GUAGE (5000 PSI)	1
15	905-03112	ADAPTER, TEE, 6MJ	2
16	905-03113	ADAPTER, ELBOW 90°, 6MJ X 6MJ	2
17	905-03250	ADAPTER, STRAIGHT, 6MJ X 4MP	11

## OUTSIDE WHEEL PLUMBING COMPONENTS

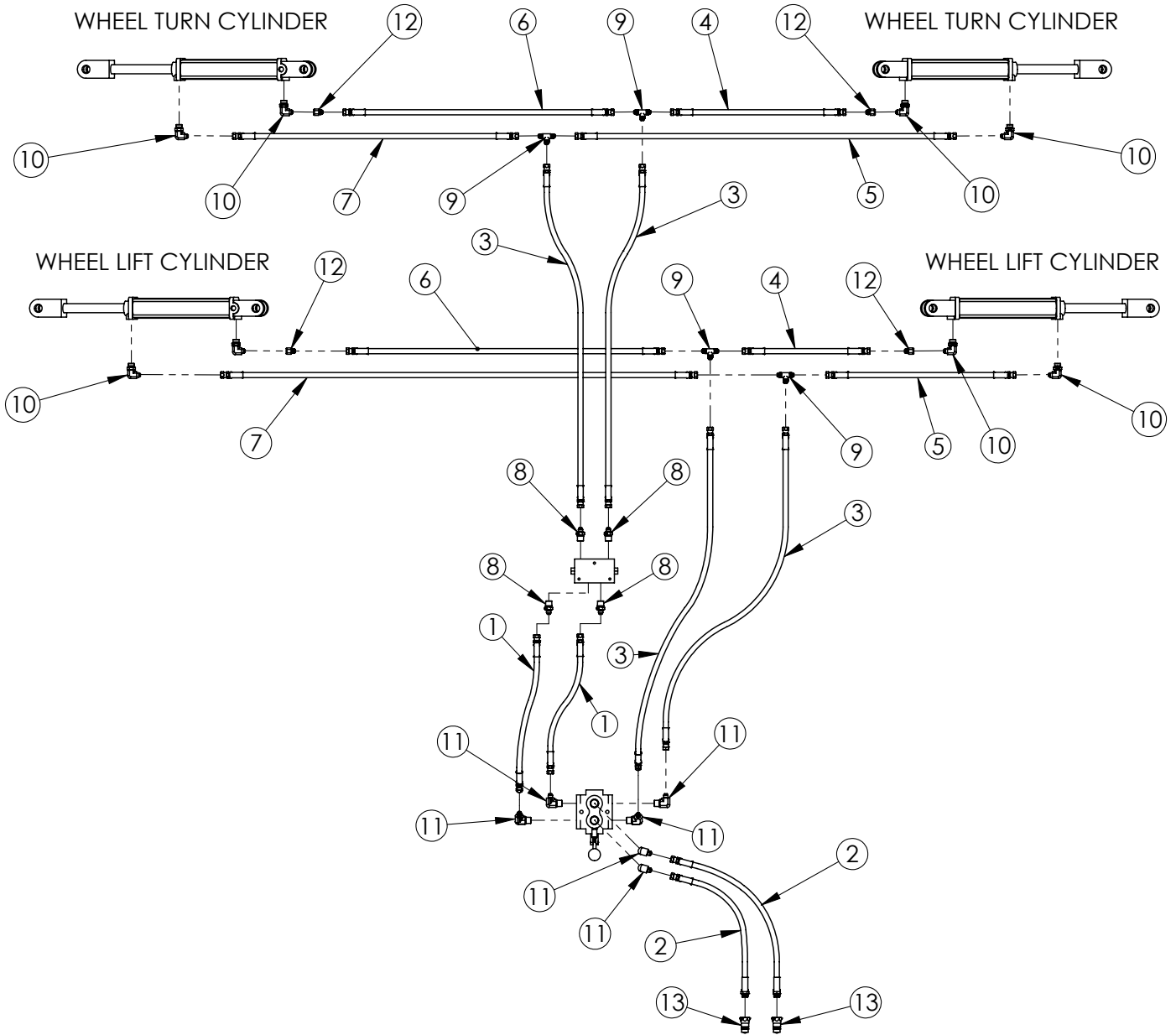

ITEM NO.	PART NUMBER	DESCRIPTION	QTY.
1	905-19217	3/8 HOSE, 6FJX x 6FJX	10.5" LENGTH 2
2	905-19210	3/8 HOSE, 8MB x 6FJX	120" LENGTH 2
3	905-19151	3/8 HOSE, 6FJX x 6FJX	134" LENGTH 4
4	905-19238	3/8 HOSE, 6FJX x 6FJX	270" LENGTH 2
5	905-19239	3/8 HOSE, 6FJX x 6FJX	284" LENGTH 2
6	905-19240	3/8 HOSE, 6FJX x 6FJX	320" LENGTH 2
7	905-19241	3/8 HOSE, 6FJX x 6FJX	334" LENGTH 2
8	905-03110	ADAPTER, STRAIGHT, 6MJ x 8MP	4
9	905-03112	ADAPTER, TEE, 6MJ	4
10	905-03114	ADAPTER, ELBOW 90°, 6MJ x 8MB	8
11	905-03117	ADAPTER, ELBOW 90°, 6MJ x 8MP	6
12	905-03220	ADAPTER, RESTRICTOR, 6FJ x 6MJ, 1/16 HOLE	4
13	905-19126	QUICK COUPLER, MALE 8FB	2

# TOOLBAR LIFT PLUMBING COMPONENTS

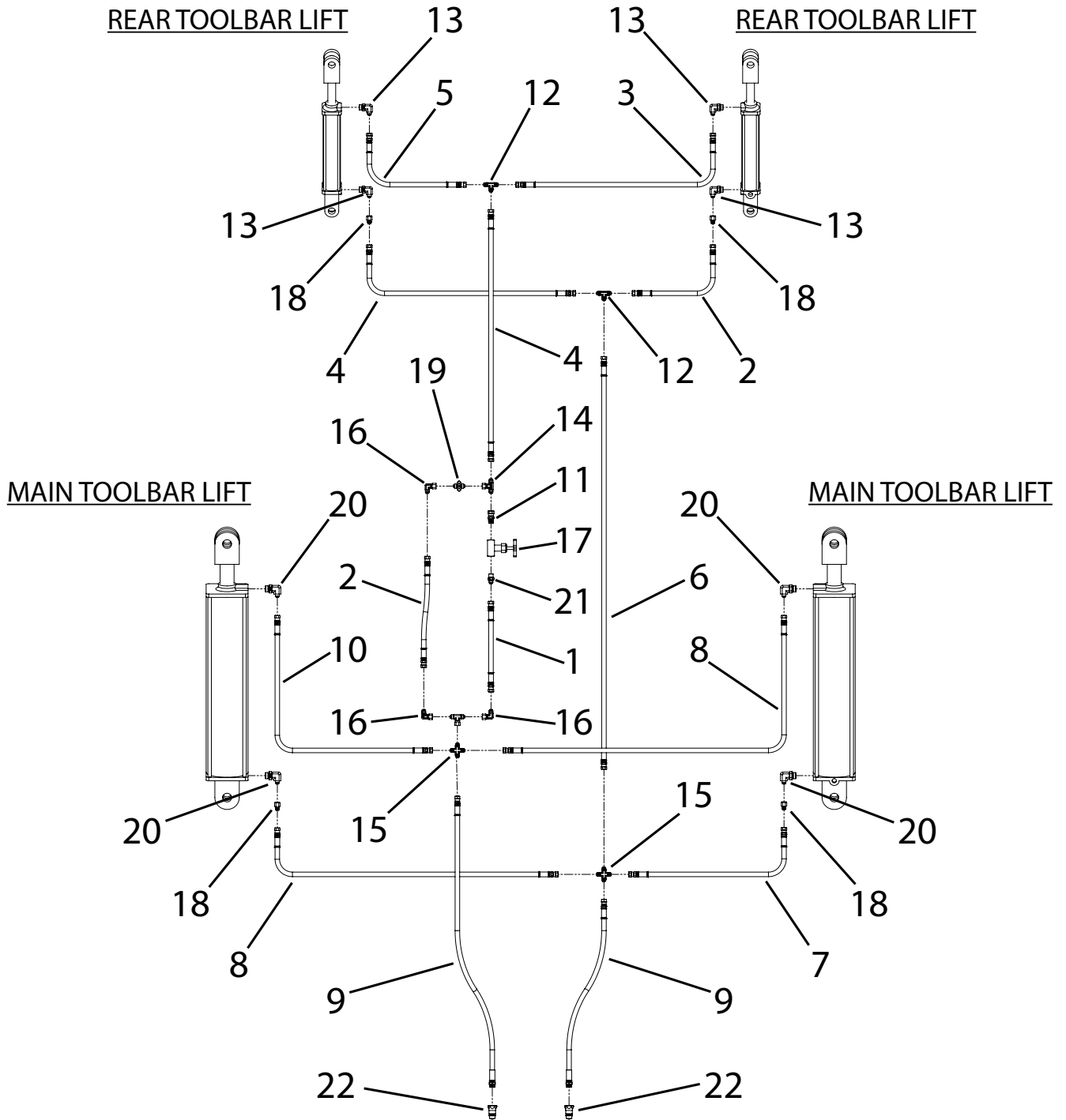



## TOOLBAR LIFT PLUMBING COMPONENTS

ITEM NO.	PART NUMBER	DESCRIPTION	QTY.
1	905-19192	3/8 HOSE, 6FJX x 6FJX	18" LENGTH 1
2	905-19191	3/8 HOSE, 6FJX x 6FJX	24" LENGTH 2
3	905-19237	3/8 HOSE, 6FJX x 6FJX	38" LENGTH 1
4	905-19196	3/8 HOSE, 6FJX x 6FJX	72" LENGTH 2
5	905-19152	3/8 HOSE, 6FJX x 6FJX	84" LENGTH 1
6	905-19153	3/8 HOSE, 6FJX x 6FJX	96" LENGTH 1
7	905-19193	3/8 HOSE, 6FJX x 6FJX	106" LENGTH 1
8	905-19202	3/8 HOSE, 6FJX x 6FJX	136" LENGTH 2
9	905-19236	3/8 HOSE, 6FJX x 8MB	155" LENGTH 2
10	905-19235	3/8 HOSE, 6FJX x 6FJX	165" LENGTH 1
11	905-01321	ADAPTER, STRAIGHT, 6MP x 6FJX	1
12	905-03112	ADAPTER, TEE, 6MJ	2
13	905-03114	ADAPTER, ELBOW 90°, 6MJ x 8MB	4
14	905-03127	ADAPTER, TEE, 6MJ x 6MJ x 6FJX	2
15	905-03141	ADAPTER, CROSS, 6MJ	2
16	905-03163	ADAPTER, ELBOW 90°, 6FJX x 6MJ	3
17	905-03209	NEEDLE VALVE, 6FP	1
18	905-03220	RESTRICTOR, 6FJ x 6MJ, 1/16 HOLE	4
19	905-03244	CHECK VALVE, 6MJ X 6MJ	1
20	905-03257	ADAPTER, ELBOW 90°, 6MJ X 10MB	4
21	905-03259	ADAPTER, STRAIGHT, 6MP X 6MJ	1
22	905-19126	QUICK COUPLER, MALE, 8FB	2

## CENTER WHEEL PLUMBING COMPONENTS

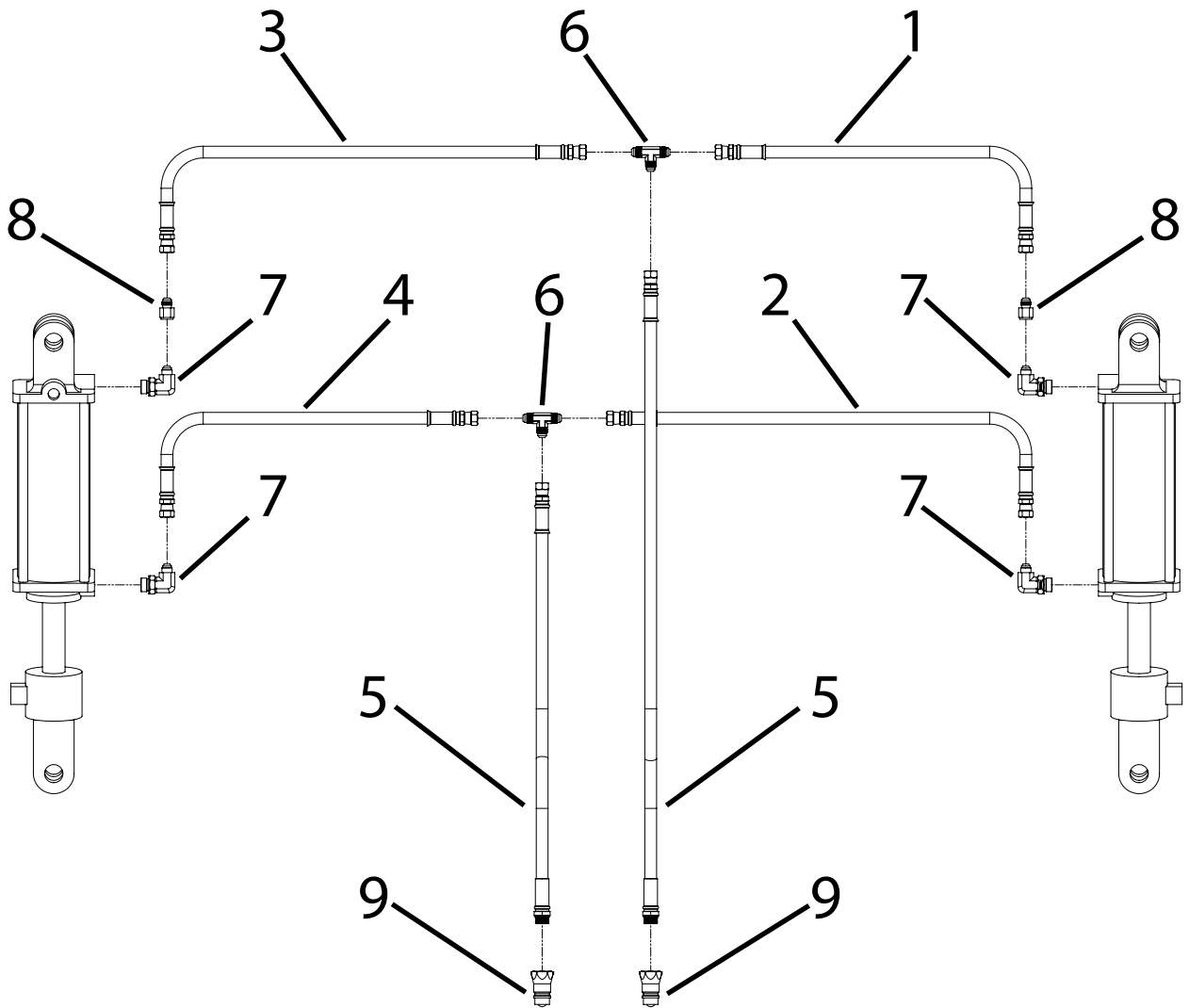

ITEM NO.	PART NUMBER	DESCRIPTION	QTY.	
1	905-19237	3/8 HOSE, 6FJX x 6FJX	90" LENGTH	1
2	905-19141	3/8 HOSE, 6FJX x 6FJX	50" LENGTH	1
3	905-19245	3/8 HOSE, 6FJX x 6FJX	90" LENGTH	1
4	905-19193	3/8 HOSE, 6FJX x 6FJX	106" LENGTH	1
5	905-19133	3/8 HOSE, 8MB x 6FJX	252" LENGTH	2
6	905-03112	ADAPTER, TEE, 6MJ		2
7	905-03114	ADAPTER, ELBOW 90°, 6MJ x 8MB		4
8	905-03220	RESTRICTOR, 6FJ x 6MJ, 1/16 HOLE		2
9	905-19126	QUICK COUPLER, MALE, 8FB		2

## HUB & SPINDLE COMPONENTS

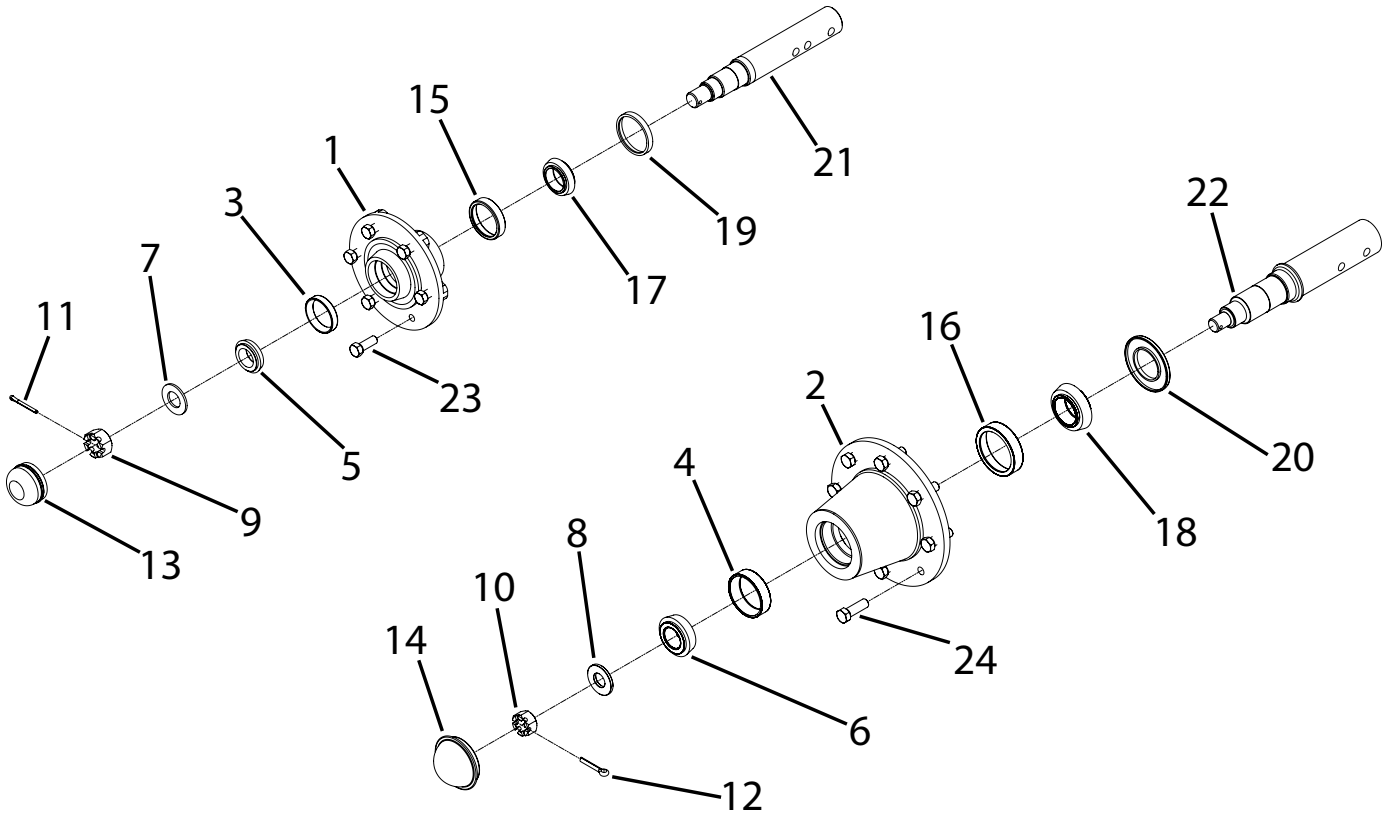

ITEM NO.	PART NUMBER	DESCRIPTION	QTY.
1	905-09004	HUB W/ CUPS (6-BOLT)	1
2	905-09136	HUB W/ CUPS (8-BOLT)	1
3	901-01016	BEARING CUP	1
4	901-01324	BEARING CUP	1
5	901-01015	BEARING CONE	1
6	901-01326	BEARING CONE	1
7	905-09068	WASHER, SAE, 1	1
8	905-09067	WASHER, SAE, 7/8	1
9	900-06062	NUT, SLOTTED, 1 NF	1
10	900-06060	NUT, SLOTTED, 7/8 NF	1
11	900-23045	PIN, COTTER, 3/16 x 2	1
12	900-23064	PIN, COTTER, 1/4 x 2	1
13	905-09009	CAP, DUST	1
14	905-09135	CAP, HUB	1
15	901-01024	BEARING CUP	1
16	901-01152	BEARING CUP	1
17	901-01025	BEARING CONE	1
18	901-01325	BEARING CONE	1
19	901-09002	SEAL, OIL	1
20	901-09215	SEAL, GREASE	1
21	200-3-4440	SPINDLE (6-BOLT)	1
22	700-3-0143	SPINDLE (8-BOLT)	1
23	905-09039	BOLT, WHEEL, 1/2	8
24	905-09039	BOLT, WHEEL, 9/16	8

## LIGHT KIT COMPONENTS

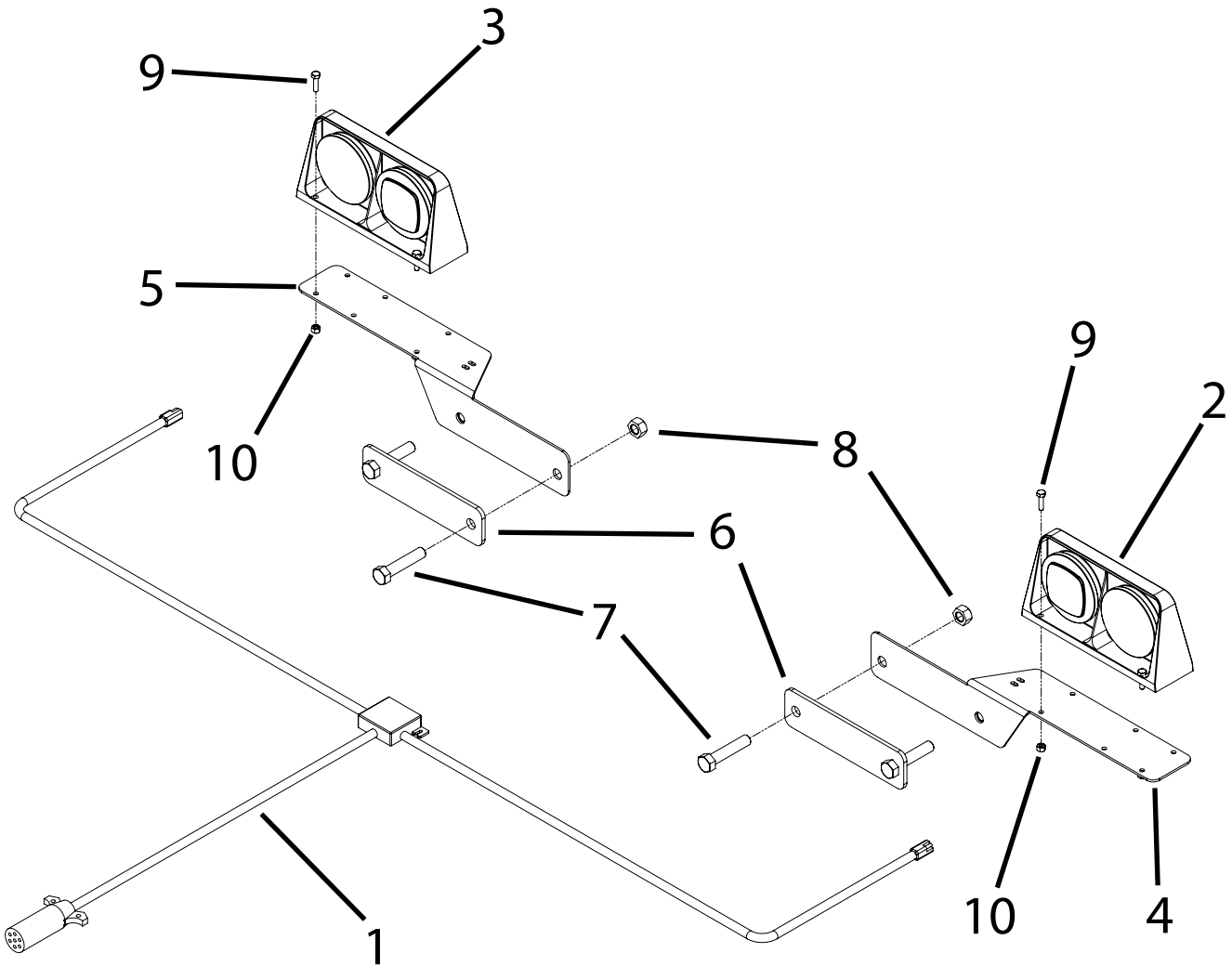



ITEM NO.	PART NUMBER	DESCRIPTION	QTY.
1	200-3-4429	WIRE HARNESS	1
2	904-01149	DUAL LAMP, LH	1
3	904-01150	DUAL LAMP, RH	1
4	200-3-3870	BRACKET, LIGHT, RH	1
5	200-3-3869	BRACKET, LIGHT, LH	1
6	200-3-4439	BRACKET, LIGHT, BACK PLATE	2
7	900-01353	BOLT, HEX HEAD, 5/8 NC x 3, GR5 ZP	4
8	900-06508	NUT, TOP LOCK, 5/8 NC	4
9	900-01009	BOLT, HEX HEAD, 1/4 NC x 1, GR5 ZP	8
10	900-06496	NUT, TOP LOCK, 1/4 NC	8

# BOLT TORQUE CHART

## SAE Series Torque Chart

Always tighten hardware to these values unless a different torque value or tightening procedure is listed for a specific application. Fasteners must always be replaced with the same grade as specified in the manual parts list.

Make sure fastener threads are clean and you properly start thread engagement.

SAE Bolt Head Identification		 SAE Grade 2 (No Dashes)		 SAE Grade 5 (3 Radial Dashes)		 SAE Grade 8 (6 Radial Dashes)	
Ⓐ Diameter (Inches)	Wrench Size	MARKING ON HEAD					
		SAE 2		SAE 5		SAE 8	
		ft./lb.	(Nm)	ft./lb.	(Nm)	ft./lb.	(Nm)
1/4"	7/16"	6	(8)	10	(13)	14	(18)
5/16"	1/2"	12	(17)	19	(26)	27	(37)
3/8"	9/16"	23	(31)	35	(47)	49	(67)
7/16"	5/8"	36	(48)	55	(75)	78	(106)
1/2"	3/4"	55	(75)	85	(115)	120	(163)
9/16"	13/16"	78	(106)	121	(164)	171	(232)
5/8"	15/16"	110	(149)	170	(230)	240	(325)
3/4"	1-1/8"	192	(261)	297	(403)	420	(569)
7/8"	1-5/16"	306	(416)	474	(642)	669	(907)
1"	1-1/2"	350	(475)	680	(925)	1020	(1383)
1-1/8"	1-11/16"	450	(610)	885	(1200)		
1-1/4"	1-7/8"	600	(815)	1255	(1700)		
1-3/8"	2-1/16"	675	(915)	1620	(2200)		
1-1/2"	2-1/4"	920	(1250)	2200	(2900)		

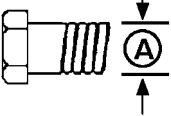

Bolt Diameter

## Metric Series Torque Chart

Use only metric tools on metric hardware. Always tighten hardware to these values unless a different torque value or tightening procedure is listed for a specific application. Fasteners must always be replaced with the same grade.

Make sure fastener threads are clean and you properly start thread engagement.

Ⓐ Diameter & Thread Pitch (Millimeters)	Wrench Size	COARSE THREAD				FINE THREAD				Ⓐ Diameter & Thread Pitch (Millimeters)	Metric Bolt Head Identification
		MARKING ON HEAD				MARKING ON HEAD					
		Metric 8.8		Metric 10.9		Metric 8.8		Metric 10.9			
		Nm	ft./lb.	Nm	ft./lb.	Nm	ft./lb.	Nm	ft./lb.		
6x1.0	10 mm	8	6	11	8	8	6	11	8	6x1.0	
8x1.25	13 mm	20	15	27	20	21	16	29	22	8x1.0	
10x1.5	16 mm	39	29	54	40	41	30	57	42	10x1.25	
12x1.75	18 mm	68	50	94	70	75	55	103	76	12x1.25	
14x2.0	21 mm	109	80	151	111	118	87	163	120	14x1.5	
16x2.0	24 mm	169	125	234	173	181	133	250	184	16x1.5	
18x2.5	27 mm	234	172	323	239	263	194	363	268	18x1.5	
20 x 2.5	30 mm	330	244	457	337	367	270	507	374	20x1.5	
22 x 2.5	34 mm	451	332	623	460	495	365	684	505	22 x 1.5	
24 x 3.0	36 mm	571	421	790	583	623	459	861	635	24 x 2.0	
30 x 3.0	46 mm	1175	867	1626	1199	1258	928	1740	1283	30 x 2.0	

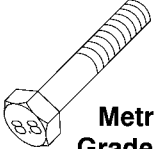

Metric Grade 8.8

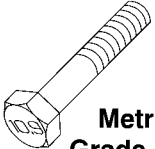

Metric Grade 10.9

## Typical Washer Installations

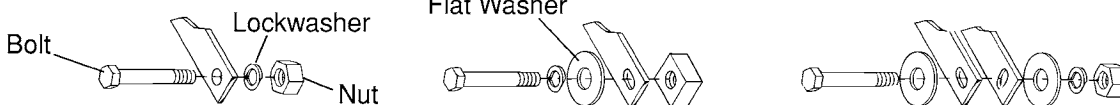

8/9/00

# ABBREVIATIONS

AG .....	Agriculture	NC .....	National Course
ASAE .....	American Society of Agricultural Engineers	NF.....	National Fine
ATF.....	Automatic Transmission Fluid	NPSM.....	National Pipe Straight Mechanical
BSPP.....	British Standard Pipe Parallel	NPT .....	National Pipe Tapered
BSPTM.....	British Standard Pipe Tapered Male	NPT SWF.....	National Pipe Tapered Swivel Female
CV .....	Constant Velocity	Nm.....	Newton Meter
CCW .....	Counter-Clockwise	OSHA...	Occupational Safety and Health Administration
CW .....	Clockwise	P .....	Pitch
DIA.....	Diameter	PBY .....	Power Beyond
EP.....	Extreme Pressure	psi.....	Pounds per Square Inch
F .....	Female	PTO.....	Power Take Off
FB.....	Female O-Ring Boss	QD .....	Quick Disconnect
FJ .....	Female Boss	RH .....	Right Hand
FJX.....	Female Swivel JIC	ROPS.....	Roll Over Protection Structure
FP .....	Female Pipe	RPM .....	Revolutions Per Minute
ft./lb.....	Foot Pound	RT.....	Right
GA .....	Gauge	SAE .....	Society of Automotive Engineers
GR (5, etc.) .....	Grade (5, etc.)	SMV .....	Slow Moving Vehicle
HHCS.....	Hex Head Cap Screw	UNC .....	Unified Coarse
HT.....	Heat Treated	UNF .....	Unified Fine
in.....	Inch	UNS.....	Unified Special
JIC.....	Joint Industry Council 37° Flare	ZP.....	Zinc Plate
kg.....	Kilogram		
km/h .....	Kilometers Per Hour		
lb.....	Pound		
LH.....	Left Hand		
LT.....	Left		
in.....	Inches		
m .....	Meter		
mm .....	Millimeter		
M .....	Male		
MB.....	Male O-Ring Boss		
MJ.....	Male JIC		
MJX.....	Male Swivel JIC		
MP .....	Male Pipe		
MPa.....	Mega Pascal		
MPH .....	Miles Per Hour		
N.....	Newton		

# INDEX

<b>ASSEMBLY</b> .....	31	<b>SAFETY</b> .....	3
<b>GENERAL</b>		Check Lists .....	10
Abbreviations .....	56	Decal Instructions .....	8-9
Bolt Torque Chart .....	55	Maintenance .....	5-6
General Information .....	1	Operation .....	4-5
Introduction .....	Inside Front Cover	Operator Sign-Off Record .....	11
Product Warranty .....	59	Preparation .....	3
Replacement Part Warranty .....	58	Storage .....	6
Specifications .....	2	Transporting .....	4
Table of Contents .....	1	<b>SERVICE &amp; MAINTENANCE</b> .....	25
<b>FIELD OPERATION</b> .....	21	Greasing .....	25
Ground Speed .....	22	Lubricants .....	25
Storage .....	23	Grease .....	25
Transporting the Unit .....	22	Storing Lubricants .....	25
<b>OPERATION</b> .....	13	Lubrication Schedule .....	26-28
Attaching the Seedbetter to the Tractor .....	16	Daily / 8hrs .....	26
Choosing the Correct Equipment .....	15	25hrs .....	27
Horsepower .....	15	40hrs .....	27
Tractor Weight .....	15	Annually .....	28
Connecting the Hydraulics .....	16	Lubrication Service Record .....	29
Folding Machine into Transport Position .....	19-20	<b>TROUBLE SHOOTING</b> .....	30
Pre-Operation Check List .....	15		
Principal Components .....	14		
Unfolding Machine into Field Position .....	17-18		
<b>PARTS INDEX</b> .....	33		

# WARRANTY

Please Enter Information Below and Save For Future Reference.

Date Purchased: \_\_\_\_\_ From (Dealer): \_\_\_\_\_

Model Number: \_\_\_\_\_ Serial Number: \_\_\_\_\_

ALLOWAY STANDARD, d/b/a ALLOWAY, warrants this product to be free from defect in material and workmanship for TWELVE (12) MONTHS COMMENCING ON THE DATE OF DELIVERY OF THE PRODUCT TO THE ORIGINAL PURCHASER.

Under no circumstances will this Warranty apply in the event that the product, in the good faith opinion of ALLOWAY, has been subjected to improper operation, improper maintenance, misuse, or an accident. This Warranty does not apply in the event that the product has been materially modified or repaired by someone other than ALLOWAY, a ALLOWAY authorized dealer or distributor, and/or a ALLOWAY authorized service center; This Warranty does not cover normal wear or tear, or normal maintenance items. This Warranty also does not cover repairs made with parts other than those obtainable through ALLOWAY.

This Warranty is extended solely to the original purchaser of the product. Should the original purchaser sell or otherwise transfer this product to a third party, this Warranty does not transfer to the third party purchaser in any way. There are no third party beneficiaries of this Warranty.

ALLOWAY makes no warranty, express or implied, with respect to tires or other parts or accessories not manufactured by ALLOWAY. Their respective manufacturers, if any, provide warranties for these items, separately. ALLOWAY'S' obligation under this Warranty is limited to, at ALLOWAYS' option, the repair or replacement, free of charge, of the product if ALLOWAY, in its sole discretion, deems it to be defective or in noncompliance with this Warranty. The product must be returned to ALLOWAY with proof of purchase within thirty (30) days after such defect or noncompliance is discovered or should have been discovered, routed through the dealer and distributor from whom the purchase was made, transportation charges prepaid. ALLOWAY shall complete such repair or replacement within a reasonable time after ALLOWAY receives the product. THERE ARE NO OTHER REMEDIES UNDER THIS WARRANTY. THE REMEDY OF REPAIR OR REPLACEMENT IS THE SOLE AND EXCLUSIVE REMEDY UNDER THIS WARRANTY.

THERE ARE NO WARRANTIES, WHICH EXTEND BEYOND THE DESCRIPTION ON THE FACE OF THIS WARRANTY. ALLOWAY MAKES NO OTHER WARRANTY, EXPRESS OR IMPLIED, AND ALLOWAY SPECIFICALLY DISCLAIMS ANY IMPLIED WARRANTY OF MERCHANTABILITY AND/OR ANY IMPLIED WARRANTY OF FITNESS FOR A PARTICULAR PURPOSE.

ALLOWAY shall not be liable for any incidental or consequential losses, damages or expenses, arising directly or indirectly from the product, whether such claim is based upon breach of contract, breach of warranty, negligence, strict liability in tort or any other legal theory. Without limiting the generality of the foregoing. Alloway specifically disclaims any damages relating to (i) lost profits, business, revenues or goodwill; (ii) loss of crops; (iii) loss because of delay in harvesting; (iv) any expense or loss Incurred for labor, supplies, substitute machinery or rental; or (v) any other type of damage to property or economic loss.

This Warranty is subject to any existing conditions of supply, which may directly affect ALLOWAYS' ability to obtain materials or manufacture replacement parts.

No agent, representative, dealer, distributor, serviceperson, salesperson, or employee of any company; including without limitation, ALLOWAY, its authorized dealers, distributors, and service centers, is authorized to alter, modify, or enlarge this Warranty.

This Warranty is effective only if the warranty registration card is returned within ten (10) days.

Answers to any questions regarding warranty service and locations may be obtained by contacting:

Alloway  
4230 14<sup>th</sup> Ave.NW  
Fargo, North Dakota 58102  
701-356-4983





## WARRANTY

ALLOWAY STANDARD, d/b/a ALLOWAY, warrants this product to be free from defect in material and workmanship for a period of One (1) year, ninety (90) days for Service Parts, from the date of delivery of the product to the original purchaser.

Under no circumstances will this Warranty apply in the event that the product, in the good faith opinion of ALLOWAY, has been subjected to improper operation, improper maintenance, misuse, or an accident. This Warranty does not cover normal wear or tear, or normal maintenance items.

This Warranty is extended solely to the original purchaser of the product. Should the original purchaser sell or otherwise transfer this product to a third party, this Warranty does not transfer to the third party purchaser in any way. There are no third party beneficiaries of this Warranty.

ALLOWAY'S obligation under this Warranty is limited to, at ALLOWAY'S option, the repair or replacement, free of charge, of the product if ALLOWAY, in its sole discretion, deems it, to be defective or in noncompliance with this Warranty. The product must be returned to ALLOWAY with proof of purchase within thirty (30) days after such defect or noncompliance is discovered or should have been discovered, routed through the dealer and distributor from whom the purchase was made, transportation charges prepaid. ALLOWAY shall complete such repair or replacement within a reasonable time after ALLOWAY receives the product. THERE ARE NO OTHER REMEDIES UNDER THIS WARRANTY. THE REMEDY OF REPAIR OR REPLACEMENT IS THE SOLE AND EXCLUSIVE REMEDY UNDER THIS WARRANTY.

THERE ARE NO WARRANTIES WHICH EXTEND BEYOND THE DESCRIPTION ON THE FACE OF THIS WARRANTY. ALLOWAY MAKES NO OTHER WARRANTY, EXPRESS OR IMPLIED, AND ALLOWAY SPECIFICALLY DISCLAIMS ANY IMPLIED WARRANTY OF MERCHANTABILITY AND/OR ANY IMPLIED WARRANTY OF FITNESS FOR A PARTICULAR PURPOSE.

ALLOWAY shall not be liable for any incidental or consequential losses, damages or expenses, arising directly or indirectly from the product, whether such claim is based upon breach of contract, breach, of warranty, negligence, strict liability in tort or any other legal theory. Without limiting the generality of the foregoing, Alloway specifically disclaims any damages relating to (i) lost profits, business, revenues or goodwill; (ii) loss of crops; (iii) loss because of delay in harvesting; (iv) any expense or loss incurred for labor, supplies, substitute machinery or rental; or (v) any other type of damage to property or economic loss.

This Warranty is subject to any existing conditions of supply, which may directly affect ALLOWAYS' ability to obtain materials or manufacture replacement parts.

No agent, representative, dealer, distributor, service person, salesperson, or employee of any company, including without limitation, ALLOWAY, Its authorized dealers, distributors, and service centers, IS authorized to alter, modify, or enlarge this Warranty.

Answers to any questions regarding warranty service and locations may be obtained by contacting:

Alloway  
4230 14<sup>th</sup> Ave.NW  
Fargo, North Dakota 58102  
701-356-4983



**PART NUMBER**  
**205-5-0007**



*Quality • Innovation*

Alloway Standard Industries  
4230 14th Avenue NW  
Fargo, North Dakota 58102

Local/Intl: 1-701-356-4983  
Toll Free: 1-877-275-8714  
Fax: 1-701-356-4985