

BEET DEFOLIATOR

2013 - 2014

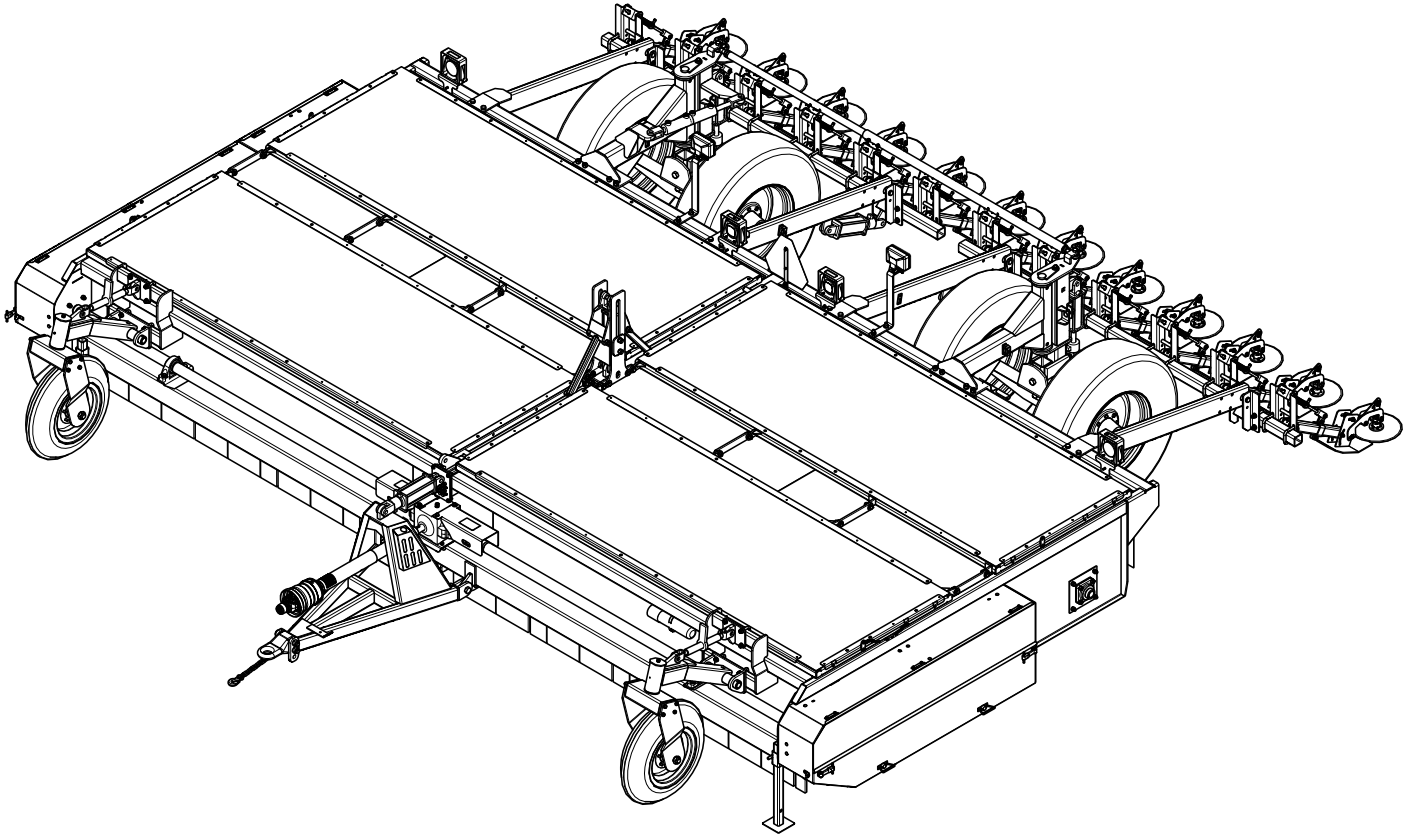

RD 132 (622)

RD 168 (628, 820)

RD 180 (630, 822)

RD 243 (830, 1220)

RD 267 (1222)



SERIAL NUMBER : 3524 - 3673

OPERATOR'S MANUAL

TO THE DEALER:

Assembly and proper installation of this product is the responsibility of the Alloway dealer. Read manual instructions and safety rules. Make sure all items on the Dealer's Pre-Delivery and Delivery Check Lists in the Operator's Manual are completed before releasing equipment to the owner.

The dealer must complete the Warranty Registration included in this manual. Both dealer and customer must sign the registration which certifies that all Dealer Check List items have been completed. The dealer is to return the prepaid postage portion to Alloway, give one copy to the customer, and retain one copy.

Note: Warranty credit is subject to this form being completed and returned.

TO THE OWNER:

Read this manual before operating your Alloway equipment. The information presented will prepare you to do a better and safer job. Keep this manual handy for ready reference. Require all operators to read this manual carefully and become acquainted with all the adjustment and operating procedures before attempting to operate. Replacement manuals can be obtained from your dealer.

The equipment you have purchased has been carefully engineered and manufactured to provide dependable and satisfactory use. Like all mechanical products, it will require cleaning and upkeep. Lubricate the unit as specified. Observe all safety information in this manual and safety decals on the equipment.

For service, your authorized Alloway dealer has trained mechanics, genuine Alloway service parts, and the necessary tools and equipment to handle all your needs.

Use only genuine Alloway service parts. Substitute parts will void the warranty and may not meet standards required for safe and satisfactory operation. Record the model number and serial number of your equipment in the spaces provided:

Model: _____ **Date of Purchase** _____

Serial Number: (see Safety Decal section for location) _____

Provide this information to your dealer to obtain correct repair parts.

Throughout this manual, the term **IMPORTANT** is used to indicate that failure to observe can cause damage to equipment. The terms **CAUTION, WARNING** and **DANGER** are used in conjunction with the Safety-Alert Symbol, (a triangle with an exclamation mark), to indicate the degree of hazard for items of personal safety.



This Safety-Alert Symbol indicates a hazard and means **ATTENTION! BECOME ALERT! YOUR SAFETY IS INVOLVED!**



Indicates an imminently hazardous situation that, if not avoided, will result in death or serious injury.



WARNING

Indicates a potentially hazardous situation that, if not avoided, could result in death or serious injury, and includes hazards that are exposed when guards are removed



CAUTION

Indicates a potentially hazardous situation that, if not avoided, may result in minor or moderate injury.

IMPORTANT

Indicates that failure to observe can cause damage to equipment.

NOTE

Indicates helpful information.



TABLE OF CONTENTS

INTRODUCTION	Inside Front Cover
GENERAL INFORMATION	1
SAFETY RULES	2 - 6
CHECK LISTS (DEALER'S RESPONSIBILITY)	7
SAFETY DECALS	8 - 9
OPERATOR SIGN-OFF RECORD	10
OPERATION	11 - 20
FIELD OPERATION	21 - 28
DEFOLIATOR STORAGE	29
SERVICE & MAINTENANCE	31 - 39
TROUBLE SHOOTING	40
INDEX TO PARTS LISTS	41
BOLT TORQUE CHART	111
ABBREVIATIONS	112
INDEX	113
REPLACEMENT PARTS WARRANTY	114
PRODUCT WARRANTY	Inside Back Cover

GENERAL INFORMATION

The purpose of this manual is to assist you in operating and maintaining your Beet Defoliator. Read it carefully. It furnishes information and instructions that will help you achieve years of dependable performance. These instructions have been compiled from extensive field experience and engineering data. Some information may be general in nature due to unknown and varying operating conditions. However, through experience and these instructions, you should be able to develop procedures suitable to your particular situation.

The illustrations and data used in this manual were current at the time of printing, but due to possible inline production changes, your machine may vary slightly in detail. We reserve the right to redesign and change the machines as may be necessary without notification.



WARNING

- **Some illustrations in this manual show the Beet Defoliator with safety shields removed to provide a better view. The Beet Defoliator should never be operated with any safety shielding removed.**

Throughout this manual, references are made to right and left direction. These are determined by standing behind the equipment facing the direction of forward travel.



SAFETY RULES

ATTENTION! BECOME ALERT! YOUR SAFETY IS INVOLVED!



Safety is a primary concern in the design and manufacture of our products. Unfortunately, our efforts to provide safe equipment can be wiped out by a single careless act of an operator.

In addition to the design and configuration of equipment, hazard control and accident prevention are dependent upon the awareness, concern, prudence and proper training of personnel involved in the operation, transport, maintenance and storage of equipment.

It has been said *"The best safety device is an informed, careful operator."* We ask you to be that kind of an operator.

TRAINING

- **Safety instructions are important! Read all attachment and power unit manuals; follow all safety rules and safety decal information. (Replacement manuals are available from dealer). Failure to follow instructions or safety rules can result in serious injury or death.**
- **If you do not understand any part of this manual and need assistance, see your dealer.**
- **Know your controls and how to stop engine and attachment quickly in an emergency.**
- **Operators must be instructed in and be capable of the safe operation of the equipment, its attachments and all controls. Do not allow anyone to operate this equipment without proper instructions.**
- **Keep hands and body away from pressurized lines. Use paper or cardboard, not body parts to check for leaks. Wear safety goggles. Hydraulic fluid under pressure can easily penetrate skin and will cause serious injury or death.**
- **Make sure that all operating and service personnel know that in the event hydraulic fluid penetrates skin, it must be surgically removed as soon as possible by a doctor familiar with this form of injury, or gangrene, serious injury or death will result. CONTACT A PHYSICIAN IMMEDIATELY IF FLUID ENTERS SKIN OR EYES. DO NOT DELAY.**
- **Never allow children or untrained persons to operate equipment.**

PREPARATION

- **Check that all hardware is tight and properly installed. Always tighten to torque chart specifications unless instructed otherwise in this manual.**
- **Air in hydraulic systems can cause erratic operation and allows loads or equipment components to drop unexpectedly. Before operating or allowing anyone to approach the equipment, purge any air in the system by operating all hydraulic functions several times after connecting equipment, connecting hoses, or doing any hydraulic maintenance.**
- **Make sure all hydraulic hoses, fittings and valves are in good condition and not leaking before starting power unit or using equipment. Check and route hoses carefully to prevent damage. Hoses must not be twisted, bent sharply, kinked, frayed, pinched, or come into contact with any moving parts. Operate moveable components through full operational range to check clearances. Replace any damaged hoses immediately.**
- **Always wear relatively tight and belted clothing to avoid entanglement in moving parts. Wear sturdy, rough-soled work shoes and protective equipment for eyes, hair, hands, hearing and head; and respirator or filter mask where appropriate.**
- **Ensure implement is properly attached, adjusted and in good operating condition.**
- **Make sure spring-activated locking pin or collar slides freely and is seated firmly in tractor PTO spline groove.**
- **Before starting power unit, check all equipment driveline guards for damage and make sure they rotate freely on all drivelines. Replace any damaged guards. If guards do not rotate freely on drivelines, repair and replace bearings before operating.**

(Safety Rules continued on next page)



SAFETY RULES

ATTENTION! BECOME ALERT! YOUR SAFETY IS INVOLVED!



(Safety Rules continued from previous page)

- Power unit must be equipped with ROPS or ROPS CAB and seat belt. Keep seat belt securely fastened. Falling off power unit can result in death from being run over or crushed. Keep foldable ROPS systems in “locked up” position at all times.
- Connect PTO driveline directly to power unit PTO shaft. Never use adapter sleeves or adapter shafts. Adapters can cause driveline failures due to incorrect spline or incorrect operating length and can result in personal injury or death.
- Inspect rubber flaps and swing rod before each use. Replace if damaged or missing. Flaps must pivot and hang freely so there are no gaps. Do not put equipment into service until repaired.
- Remove accumulated debris from this equipment, tractor and engine to avoid fire hazard.
- Ensure all safety decals are installed. Replace if damaged. (See Safety Decals section for location.)
- Ensure shields and guards are properly installed and in good condition. Replace if damaged.
- A minimum 20% of tractor and equipment weight must be on tractor front wheels when attachments are in transport position. Without this weight, tractor could tip over, causing personal injury or death. The weight may be attained with a loader, front wheel weights, ballast in tires or front tractor weights. When attaining the minimum 20% weight on the front wheels, you must not exceed the Roll Over Protection Structure (ROPS) weight certification. Weigh the tractor and equipment. Do not estimate.
- Make sure hydraulic hoses and cylinders are fully purged of air before operating. Keep all persons away and fill the system by raising and lowering all functions several times. Air in the system can allow components to fall unexpectedly.
- Inspect and clear area of stones, branches, or other hard objects that might be thrown, causing injury or damage.

TRANSPORTING

- Power unit must be equipped with ROPS or ROPS cab and seat belt. Keep seat belt securely fastened. Falling off power unit can result in death from being run over or crushed. Keep foldable ROPS systems in “locked up” position at all times.
- Always sit in power unit seat when operating controls or starting engine. Securely fasten seat belt, place transmission in neutral, engage brake, and ensure all other controls are disengaged before starting power unit engine.
- A minimum 20% of tractor and equipment weight must be on the tractor front wheels when attachments are in transport position. Without this weight, tractor could tip over, causing personal injury or death. The weight may be attained with a loader, front wheel weights, ballast in tires or front tractor weights. Weigh the tractor and equipment. Do not estimate.
- Always attach safety chain to tractor drawbar when transporting unit.
- Always raise unit and install transport locks before transporting. Leak down or failure of mechanical or hydraulic system can cause equipment to drop.
- Never exceed 20 MPH during transport. See the Speed vs. Weight Ratio Table in "Field Operation, Transporting the Unit" for proper tow vehicle to machine weight ratios.
- Watch for hidden hazards on the terrain.
- Always comply with all state and local lighting and marking requirements.
- Never allow riders on power unit or attachment.
- Do not operate PTO during transport.
- Look down and to the rear and make sure area is clear before operating in reverse.
- Do not operate or transport on steep slopes.

(Safety Rules continued on next page)



SAFETY RULES

ATTENTION! BECOME ALERT! YOUR SAFETY IS INVOLVED!



(Safety Rules continued from previous page)

- Use extreme care and reduce ground speed on slopes and rough terrain.
- Do not operate or transport equipment while under the influence of alcohol or drugs.

OPERATION

- Equipment may be pictured with covers open for instructional purposes. Never operate equipment with covers open.
- Do not allow bystanders in the area when operating, attaching, removing, assembling, or servicing equipment.
- Do not allow anyone to stand between tractor and unit when backing up to unit.
- Never go underneath equipment (lowered to the ground or raised) unless it is properly blocked and secured. Never place any part of the body underneath equipment or between moveable parts even when the engine has been turned off. Hydraulic system leak down, hydraulic system failures, mechanical failures, or movement of control levers can cause equipment to drop or rotate unexpectedly and cause severe injury or death. Follow Operator's Manual instructions for working underneath and blocking requirements or have work done by a qualified dealer.
- Keep bystanders away from equipment.
- Do not operate or transport equipment while under the influence of alcohol or drugs.
- Operate only in daylight or good artificial light.
- Avoid contact with electrical wires.
- Keep hands, feet, hair, and clothing away from equipment while engine is running. Stay clear of all moving parts.
- Always comply with all state and local lighting and marking requirements.

- Never allow riders on power unit or attachment.
- Power unit must be equipped with ROPS or ROPS cab and seat belt. Keep seat belt securely fastened. Falling off power unit can result in death from being run over or crushed. Keep foldable ROPS systems in "locked up" position at all times.
- Always sit in power unit seat when operating controls or starting engine. Securely fasten seat belt, place transmission in neutral, engage brake, and ensure all other controls are disengaged before starting power unit engine.
- Operate tractor PTO at the RPM speed stated in "Specifications" section.
- Do not operate PTO during transport.
- Look down and to the rear and make sure area is clear before operating in reverse.
- Do not operate or transport on steep slopes.
- Do not stop, start, or change directions suddenly on slopes.
- Use extreme care and reduce ground speed on slopes and rough terrain.
- Watch for hidden hazards on the terrain during operation.
- Stop power unit and equipment immediately upon striking an obstruction. Turn off engine, remove key, inspect, and repair any damage before resuming operation.
- Never work on scalper attachment in the raised position. Lower scalpels to the ground and service each unit individually.
- Always raise scalper arms before going in reverse.
- Always connect safety chain from equipment to towing vehicle when transporting.

(Safety Rules continued on next page)



SAFETY RULES

ATTENTION! BECOME ALERT! YOUR SAFETY IS INVOLVED!



(Safety Rules continued from previous page)

■ AVOID INJURY OR DEATH FROM POWER LINES:

- Stay away from power lines.
- Electrocutation can occur without direct contact.
- Check clearances before raising implement.
- Do not leave the operator's seat if any part of the tractor or implement contacts electric lines.

■ Before servicing, adjusting, repairing or unplugging, stop tractor engine, place all controls in neutral, set park brake, remove ignition key, and wait for all moving parts to stop.

■ Before working underneath a raised implement, read and follow all Operator's Manual instructions and safety rules. Implement must be attached to tractor. Lift cylinder locks must be installed and lift cylinders lowered against locks. Hydraulic system leak down, hydraulic system failures, or movement of control levers can cause equipment to drop unexpectedly and cause severe injury or death.

MAINTENANCE

■ Before servicing, adjusting, repairing or unplugging, stop tractor engine, place all controls in neutral, set park brake, remove ignition key, and wait for all moving parts to stop.

■ Before working underneath a raised implement, read and follow all Operator's Manual instructions and safety rules. Implement must be attached to tractor. Lift cylinder locks must be installed and lift cylinders lowered against locks. Hydraulic system leak down, hydraulic system failures, or movement of control levers can cause equipment to drop unexpectedly and cause severe injury or death.

■ Service and maintenance work not covered in OWNER SERVICE must be done by a qualified dealership. Special skills, tools, and safety procedures may be required. Failure to follow these instructions can result in serious injury or death.

■ Do not modify or alter or permit anyone else to modify or alter the equipment or any of its components in any way.

■ Your dealer can supply original equipment hydraulic accessories and repair parts. Substitute parts may not meet original equipment specifications and may be dangerous.

■ Always wear relatively tight and belted clothing to avoid entanglement in moving parts. Wear sturdy, rough-soled work shoes and protective equipment for eyes, hair, hands, hearing and head; and respirator or filter mask where appropriate.

■ Do not allow other people in the area when operating, attaching, removing, assembling or servicing equipment.

■ Never go underneath equipment lowered to the ground or raised, unless it is properly blocked and secured. Never place any part of the body underneath equipment or between moveable parts even when the engine has been turned off. Hydraulic system leak down, hydraulic system failures, mechanical failures or movement of control levers can cause equipment to drop or rotate unexpectedly and cause severe injury or death. Follow Operator's Manual instructions for working underneath and blocking requirements, or have work done by a qualified dealer.

■ Ensure implement is properly attached, adjusted and in good operating condition.

■ Never perform service or maintenance with engine running.

■ Make sure hydraulic hoses and cylinders are fully purged of air before operating. Keep all persons away and fill the system by raising and lowering all functions several times. Air in the system can allow components to fall unexpectedly.

■ Keep all persons away from operator control area while performing adjustments, service or maintenance.

(Safety Rules continued on next page)



SAFETY RULES

ATTENTION! BECOME ALERT! YOUR SAFETY IS INVOLVED!



(Safety Rules continued from previous page)

- **Make certain all movement of implement components has stopped before approaching for service.**
- **Do not handle blades with bare hands. Careless or improper handling may result in serious injury.**
- **Tighten all bolts, nuts and screws to torque chart specifications. Check that all cotter pins are installed securely to ensure equipment is in a safe condition before operating.**
- **Ensure all safety decals are installed. Replace if damaged. (See Safety Decals section for location.)**

- **Ensure shields and guards are properly installed and in good condition. Replace if damaged.**
- **Do not disconnect hydraulic lines until machine is securely blocked or placed in lowest position and system pressure is released by operating all valve control levers.**

STORAGE

- **Follow manual instructions for storage.**
- **Keep children and bystanders away from storage area.**

CHECK LISTS

PRE-DELIVERY CHECK LIST

(DEALER'S RESPONSIBILITY)

Inspect the equipment thoroughly after assembly to ensure it is set up properly before delivering it to the customer.

The following check lists are a reminder of points to inspect. Check off each item as it is found satisfactory or after proper adjustment is made.

- Check that all safety decals are installed and in good condition. Replace if damaged.
- Check that shields and guards are properly installed and in good condition. Replace if damaged.
- Check that PTO shaft is properly installed.
- Properly attach implement to tractor and make all necessary adjustments.
- Check all bolts to be sure they are tight.
- Check wheel bolts for proper torque.
- Check that all cotter pins and safety pins are properly installed. Replace if damaged.
- Check and grease all lubrication points as identified in "Service, lubrication information."
- Check the level of gearbox fluids before delivery. Service, if required, as specified in the "Service, lubrication information."
- Check that tractor hydraulic reservoir has been serviced and that hydraulic system and all functions have been operated through full cylinder stroke to purge air from system.
- After pressurizing and operating all Defoliator functions, stop tractor and make sure there are no leaks in the hydraulic system. Follow all safety rules when checking for leaks.

DELIVERY CHECK LIST

(DEALER'S RESPONSIBILITY)

- Check that all safety decals are installed and in good condition. Replace if damaged.
- Show customer how to make adjustments and select proper PTO speed.
- Show customer how to make adjustments.
- Instruct customer how to lubricate and explain importance of lubrication.
- Point out the safety decals. Explain their meaning and the need to keep them in place and in good condition. Emphasize the increased safety hazards when instructions are not followed.
- Present Operator's Manual and request that customer and all operators read it before operating equipment. Point out the manual safety rules, explain their meanings and emphasize the increased safety hazards that exist when safety rules are not followed.
- Show customer how to make sure driveline is properly installed and that spring-activated locking pin or collar slides freely and is seated in groove on tractor PTO shaft.
- Show customer the safe, proper procedures to be used when mounting, dismounting, and storing equipment.
- Explain to customer that when equipment is transported on a road or highway, safety devices should be used to give adequate warning to operators of other vehicles.
- Explain to customer that when equipment is transported on a road or highway, a Slow Moving Vehicle (SMV) sign should be used to provide adequate warning to operators of other vehicles.
- Explain to customer that when towing on a public road to comply with all state and local lighting/marketing laws and to use a safety tow chain.
- Make customer aware of optional equipment available so that customer can make proper choices as required.
- Point out all guards and shields. Explain their importance and the safety hazards that exist when not kept in place and in good condition.



SAFETY & INSTRUCTIONAL DECALS

ATTENTION! BECOME ALERT! YOUR SAFETY IS INVOLVED!
Replace Immediately If Damaged!

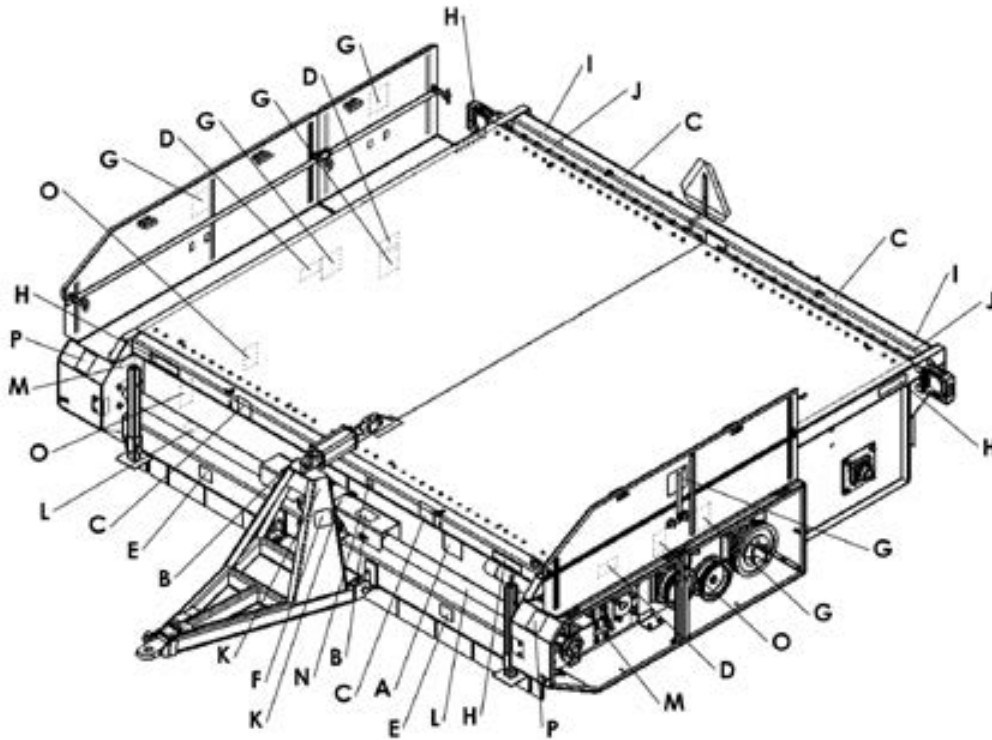

A. 500-3-0977 Caution (1-11)



B. 100-3-1367 Safety Guard



C. 500-3-0981 Rotating Flails



D. 500-3-0980 Missing Shields Warning
 SERIAL # 3524 - 3673



E. 500-3-0982 Rotating Flails



F. 500-3-0978 Rotating PTO
 (Safety Decals continued on next page)



SAFETY & INSTRUCTIONAL DECALS

ATTENTION! BECOME ALERT! YOUR SAFETY IS INVOLVED!
Replace Immediately If Damaged!



G. 500-3-0979 Rotating Part



H. 200-3-4004 Amber Reflector 9 x 2



I. 200-3-4005 Red Reflector 9 x 2



J. 200-3-4034 Orange Fluorescent Reflector 9 x 2



K. 506-3-0194 Shield Missing Warning



M. 500-3-1149 Belt Tension



N. 200-3-1366 Serial Number Tag



P. 500-3-1690 Do Not Walk / Stand



L. 903-17456 Driveline Safety Sign

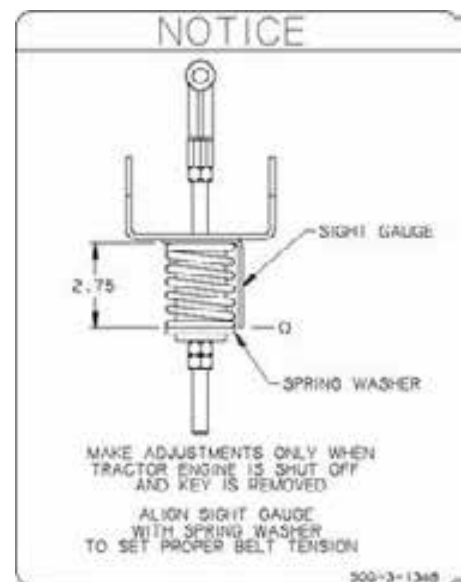

O. 500-3-1348 Belt Tension

OPERATION

Safety is a primary concern in the design and manufacture of our products. Unfortunately, our efforts to provide safe equipment can be wiped out by an operator's single careless act.

In addition to the design and configuration of equipment, hazard control and accident prevention are dependent upon the awareness, concern, judgment, and proper training of personnel involved in the operation, transport, maintenance and storage of equipment.

It has been said "The best safety device is an informed, careful operator." We ask you to be that kind of operator.

The Alloway Beet Defoliator is designed to efficiently remove the foliage from sugar beets. A series of rubber or steel flails on three drums cleans the top of the beet, leaving the exposed crown.

Be familiar with the defoliator before starting.

The owner is responsible for training operators in the safe operation of the defoliator.



WARNING

- **Safety instructions are important! Read all attachment and power unit manuals; follow all safety rules and safety decal information. (Replacement manuals are available from your dealer). Failure to follow instructions or safety rules can result in serious injury or death.**
- **Never allow children or untrained persons to operate equipment.**
- **Make sure shields and guards are properly installed and in good condition. Replace if damaged.**
- **Keep hands, feet, hair, and clothing away from equipment while engine is running. Stay clear of all moving parts.**
- **Keep bystanders away from equipment.**
- **Operate tractor PTO at the RPM speed stated in "Specifications" section.**
- **Before dismounting power unit or performing any service or maintenance, follow these steps: disengage power to implement, lower the hitch and all raised components to the ground, operate valve levers to release any hydraulic pressure, set parking brake, stop engine, remove key, and unfasten seat belt.**



WARNING

- **Keep bystanders away from equipment.**
- **Never allow riders on power unit or attachment.**
- **Do not allow bystanders in the area when operating, attaching, removing, assembling, or servicing equipment.**
- **Keep hands, feet, hair, and clothing away from equipment while engine is running. Stay clear of all moving parts.**



CAUTION

- **Always sit in tractor seat when operating controls or starting engine. Securely fasten seat belt, place transmission in neutral, engage brake, and ensure all other controls are disengaged before starting tractor engine.**
- **Always comply with all state and local lighting and marking requirements.**
- **Always wear relatively tight and belted clothing to avoid entanglement in moving parts. Wear sturdy, rough-soled work shoes and protective equipment for eyes, hair, hands, hearing, and head.**

Operation Continued

PRINCIPAL COMPONENTS

The Alloway Beet Defoliator consists of three rotating drums that have steel or rubber flails. The flails remove the foliage from the plant. Rotational power to

the drums is provided from the tractor PTO through a series of belts on each side of the machine.

An optional scalper package is available on the back of the machine to cut off the top of the remaining beet.

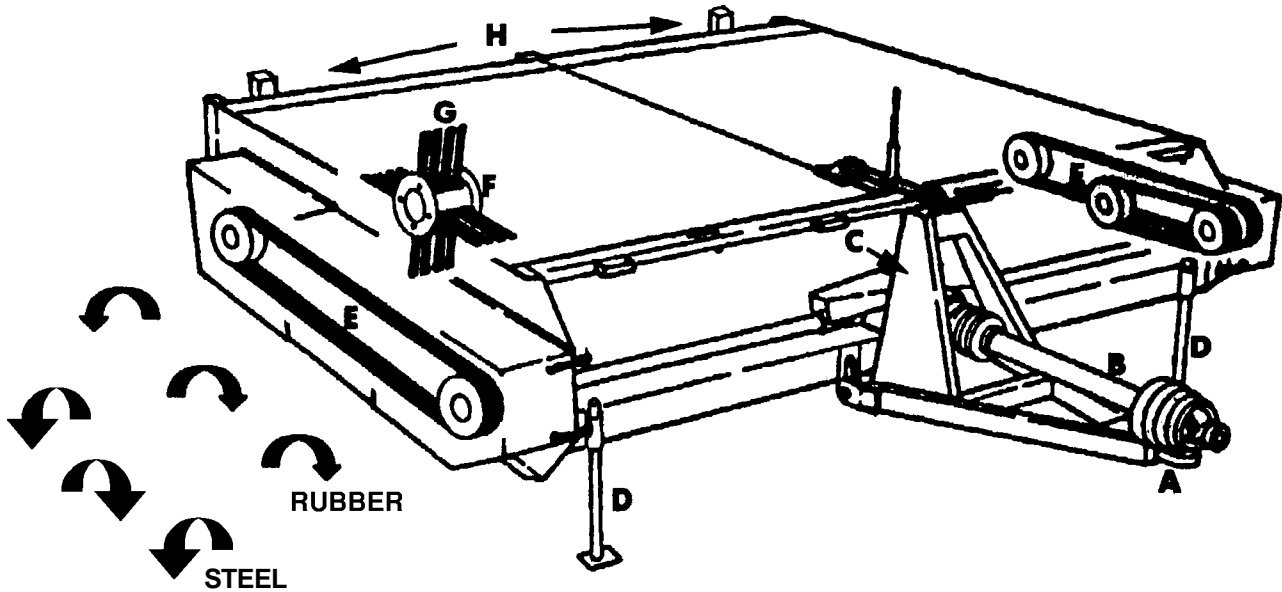

- A. Hitch
- B. Input Driveline
- C. Gearbox
- D. Stands
- E. Belt
- F. Rotor
- G. Flails
- H. Wheels

Figure 1. Beet Defoliator Principal Components

Operation Continued

BEET DEFOLIATOR BREAK-IN

The following should be observed when operating the unit for the first time:

1. Attach PTO shaft. Remove grease zerks to gain access to the set screws for tightening on unit.

After operating for 1/2 hour or after completing five acres

2. Check all nuts, bolts, and other fasteners. Tighten to specifications given in the Bolt Torque Chart, page 105.
3. Check and re-torque on flail mounting bracket fasteners
4. Tighten wheel bolts to specifications given in the Bolt Torque Chart, page 105.
5. Check that the flails are in good condition and swing freely,
6. Check oil level in the gearbox. Add oil as required.
7. Check that the PTO driveline shield turns freely.
8. Lubricate all grease points.

After operating for 5 hours

9. Repeat Steps 1 through 6 above.
10. Check the tension of the drive belts. Refer to the Service and Maintenance section for the procedure. Adjust as required.

After operating for 10 hours

11. Repeat steps 1 through 6.
12. Check tension of drive belts. Adjust as required.

After operating for 15, and 20 hours

13. Check tension of drive belts. Adjust as required.

PRE-OPERATION CHECK LIST

(OWNER'S RESPONSIBILITY)

IMPORTANT

- **This Pre-Operation Check List is provided for the operator. It is important to follow for both personal safety and maintenance of the beet defoliator.**

- Check that all safety decals are installed and in good condition. Replace if damaged.
- GENL-LUBE--Check all lubrication points and grease as instructed in Lubrication Schedule.
- Use only a tractor of adequate power and weight to pull the unit.
- Check that the unit is properly attached to the tractor. On pull-type unit, be sure there is a mechanical retainer through the drawbar pin and the safety chain is installed.
- Check oil level in gearbox. Add oil as required.
- Check that the PTO driveline turns freely and that the driveline can telescope easily.
- Check tire pressure. Bring to specified level.
- Check flails. Inspect for damage or breakage. Make sure they swing freely on their mount. Repair or replace as required.
- Check the condition of all drive belts. Align as required. Replace those that are frayed or broken. Refer to Belt Replacement.
- Check the condition of the scalpers. Adjust or repair as required. Refer to Scalpers.
- Inspect all hydraulic lines, hoses, couplers, and fittings. Tighten, repair, or replace any leaking or damaged components.
- Close and secure all guards, doors, and covers.

Operation Continued

CHOOSING THE CORRECT EQUIPMENT

To ensure safe and reliable operation of the beet defoliator, use a tractor with the correct specifications. Use the following guidelines to select the correct tractor.

PTO

The defoliator is equipped with a PTO driveline yoke to fit a 1-3/8" 21 spline shaft on the tractor. An optional 1-3/4" 20 spline yoke is available from the factory if required. Be sure to match the yoke to your tractor shaft.

IMPORTANT

- Do not use an adapter on the tractor shaft. It will alter the drawbar dimension and can affect the strength of the shaft.

DRAWBAR

The tractor drawbar must be set to provide 16" (406mm) between the end of the PTO shaft and the center of the drawbar pin.

IMPORTANT

- Do not use PTO shaft adapters. They will change the drawbar dimension and can cause driveline failures.

NOTE: Verify that no driveline interference occurs through all phases of operation (bottoming out).

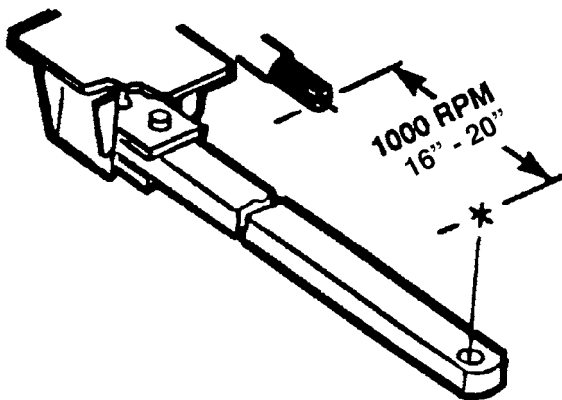

Figure 2a. Drawbar Dimension



Figure 2b. PTO Driveline

HYDRAULIC SYSTEM

The tractor hydraulic system must be capable of 8 gpm (22 lpm) at 2,500 psi (1700 kPa). Either closed-centered or open-centered system can be used. A remote outlet is required for each circuit.

Operation *Continued*

ATTACHING THE DEFOLIATOR TO THE TRACTOR

Place unit on a level, dry area free of debris and other foreign objects



WARNING

■ **Keep bystanders away from equipment.**

1. Clear the area of all bystanders.
2. Provide enough clearance to back the tractor safely into the unit.



CAUTION

■ **Do not allow anyone to stand between tractor and unit when backing up to the unit.**

3. Back slowly and align the drawbar with the hitch.
4. Shut off the tractor, place all controls in neutral, set the parking brake, remove the key, and wait for all moving parts to stop.
5. Use the ratchet on top of the hitch A-frame to set the height (9 row model and smaller). The operator must supply his own hydraulic cylinder on the 12-row model.
6. On the 12-row defoliator, connect the hoses from the hitch cylinder to the tractor hydraulics to raise or lower the hitch.
7. Use the hardened drawbar pin with provisions for a mechanical retainer. Install a retainer, such as a Klik pin.
8. Be sure the drawbar is pinned in its center position.
9. Attach the safety chain around the drawbar or cage to prevent unexpected separation. Provide sufficient slack for turning.
10. Connect the PTO driveline.
11. Check that the driveline telescopes easily and that the shield rotates freely with no interference.
12. Attach the driveline to the tractor by retracting the locking collar; slide the yoke over the shaft and push on the yoke until the lock collar clicks into position. Be sure the yoke is locked in position.
13. Attach the anchor chain on the driveline shield to the frame.

Operation Continued

CONNECT THE HYDRAULICS

1. Use a clean cloth or paper towel to clean the couplers on the end of the hoses and the area around the couplers on the tractor.
2. Insert the male ends into the couplers on the tractor. Be sure they are locked in place.
3. Route the hoses along the hitch and secure in position with clips, tape, or plastic ties. Provide sufficient slack for turning.



Figure 3. Driveline and Hydraulics Attached



WARNING

- Keep hands and body away from pressurized lines. Use paper or cardboard, not hands or other body parts to check for leaks. Wear safety goggles. Hydraulic fluid under pressure can easily penetrate skin and will cause serious injury or death.
- Make sure all hydraulic hoses, fittings, and valves are in good condition and not leaking before starting power unit or using equipment. Check and route hoses carefully to prevent damage. Hoses must not be twisted, bent sharply, kinked, frayed, pinched, or come into contact with any moving parts. Operate moveable components through full operational range to check clearances. Replace any damaged hoses immediately.

COMPLETE ATTACHMENT

1. Use ratchet or hydraulic cylinder on the hitch to lower the hitch and transfer the weight to the drawbar. See Figure 4.
2. Unpin the front frame stands. Raise the stands and pin them in their stowed positions. See Figure 5.

REMOVING THE DEFOLIATOR FROM THE TRACTOR

Reverse the above procedure when unhooking from the tractor.



Figure 4. Hitch Cylinder



Figure 5. Parking Stand

Operation *Continued*

MACHINE SETTINGS

The machine can give its best performance only if it is properly set to work in the existing condition. It may be necessary to change the machine settings during the working day if the machine is moved to a new field, or the operating conditions change.

Review this section to be familiar with the adjustments available to match the machine to the working conditions.

MACHINE LEVELING

The frame must be set level when working in the field to be sure that the flails contact the plants evenly at any place under the frame. Set when the machine is on firm, level ground. Use a tape to measure the distance between the frame and the ground, or place a level on top of the frame.

1. Use the ratchet or hydraulic cylinder on the hitch (Figure 4) to level the frame in the direction of travel.
2. Turn the adjustment crank on the rear wheels (Figure 7) to level the machine from side to side. Loosen the "U" bolt on the wheel strut, turn the crank and re-tighten the bolt.



Figure 6. Hitch Cylinder



Figure 7. Rear Wheels

(Machine Settings continued on next page)

Operation Continued

(Machine Settings continued from previous page)

FLAIL HEIGHT

Best results are obtained when the flails contact the sugar beets approximately 1/2 inch (12 mm) below the crown. This will allow the flails to remove the foliage from the beets during a pass.

Set the height of the flails by changing the height of the machine from the ground. Machine height is set with the ratchet or hydraulic cylinder on the hitch and the height of the rear wheels.

IMPORTANT

- **Maintain a level machine at all times.**

In soft or wet conditions, the tires will sink into the soil and the machine should be raised to maintain the flail contact line of 1/2 inch (12 mm) below the crown.

In crop conditions where the beet crown extends above the ground and can be knocked over, the flails can be set so that they just contact the crown.

Do not allow the flails to contact the ground. They will pick up dirt, sticks, stones and other material that can be thrown out and cause injury. This will also cause rapid wear or breakage.

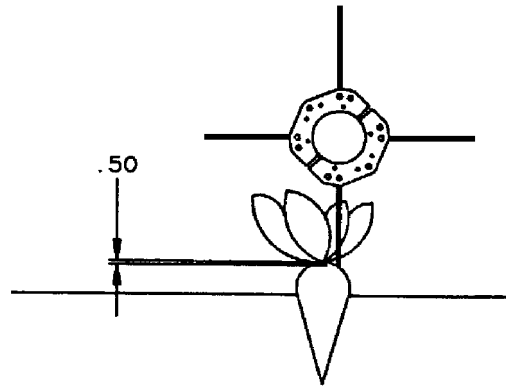

Figure 8. Flail Height



Figure 9. Machine Height

FLAIL SPACING

Set flail position on the drum to follow beet rows exactly and to clean the low foliage from both sides of the crown. Change spacing of flail sets by loosening the clamping bolts on the head, and sliding the entire assembly to its new position on the rotor



Figure 10. Flail Assembly

(Machine Settings continued on next page)

Operation Continued

(Machine Settings continued from previous page)

WHEEL SPACING

The rear wheels must be set to track directly between the rows. Any other positions can lead to beet contact and damage or knocking the beet out of the ground.

Change the wheel assembly position by jacking up the machine, loosening the top mounting bolts (Figure 11), and sliding the assembly to its desired position. Re-tighten the bolts and remove jacks.



Figure 11. Wheel Mounting Bolts

STABILIZER WHEEL POSITION

Stabilizer wheels located on the front corners of the 12 row machine (Figure 12). They must be set to the correct height to prevent dipping, thus preventing machine and plant damage.



Figure 12a. Stabilizer Wheel Mounting Position

Operation *Continued*

SCALPER SETTINGS (Optional)

Three types of scalpers are available:

- Knife (Figure 14)
- Circular (parallel arms) - (not shown; refer to Parallel Arm Rotary Scalper)
- Circular (arms) - (not shown, refer to Rotary Scalper Long Arm)

Scalpers cut the top of the crown and are positioned on the back of the machine.

The shoe, ahead of the cutting surface, must be set at the proper angle. This will allow sufficient space for the knives to cut the green portion of the beets without tipping them over.

IMPORTANT

- **Severe equipment damage may occur if attempting to go in reverse with the scalper arms down. Always raise scalper arms before going in reverse.**



Figure 14. Knife Scalpers

FIELD OPERATION

The Alloway beet defoliator is designed with the flexibility to operate well in almost any kind of crop and terrain conditions. However, the operator is responsible for being familiar with all operating and safety procedures and following them.

Each operator should review this Field Operation section at the start of the season and as often as required to be familiar with the unit.

Operators should also review the Pre-Operation Check List, Attaching the Defoliator to the Tractor, and Transporting the Unit.



WARNING

- Operators must be instructed in and be capable of the safe operation of the equipment, its attachments, and all controls. Do not allow anyone to operate this equipment without proper instructions.
- Always comply with all state and local lighting and marking requirements.
- Always wear relatively tight and belted clothing to avoid entanglement in moving parts. Wear sturdy, rough-soled work shoes and protective equipment for eyes, hair, hands, hearing, and head.
- Do not allow bystanders in the area when operating, attaching, removing, assembling, or servicing equipment.
- Never allow riders on power unit or attachment.
- Before dismounting power unit or performing any service or maintenance, follow these steps: disengage power to implement, lower the 3-point hitch and all raised components to the ground, operate valve levers to release any hydraulic pressure, set parking brake, stop engine, remove key, and unfasten seat belt.
- Keep hands, feet, hair, and clothing away from equipment while engine is running. Stay clear of all moving parts.
- Make sure shields and guards are properly installed and in good condition. Replace if damaged.
- Never allow children or untrained persons to operate equipment.



WARNING

- Safety instructions are important! Read all attachment and power unit manuals; follow all safety rules and safety decal information. (Replacement manuals are available from dealer. Failure to follow instructions or safety rules can result in serious injury or death.
- Keep hands, feet, hair, and clothing away from equipment while engine is running. Stay clear of all moving parts.
- Inspect and clear area of stones, branches, or other hard objects that might be thrown, causing injury or damage.
- Operate tractor PTO at the RPM speed stated in “Specifications” section.



CAUTION

- Always sit in tractor seat when operating controls or starting engine. Securely fasten seat belt, place transmission in neutral, engage brake, and ensure all other controls are disengaged before starting tractor engine.

Field Operation *Continued*

TRANSPORTING THE UNIT



WARNING

- Never allow riders on power unit or attachment.



CAUTION

- Always comply with all state and local lighting and marking requirements.

1. Be sure all bystanders are clear of the unit.
2. Be sure center cutter is disengaged and has stopped turning (if so equipped).
3. Be sure the unit is securely attached to the tractor and all retainer pins are installed.
4. Be sure safety chain is installed on pull-type model.
5. Raise the machine.
6. Clean the SMV emblem, lights, and reflectors and be sure they are working.
7. Be sure you are in compliance with all applicable lighting and marking regulations when transporting. Check with your local authorities.
8. Never transport the unit faster than 20 mph (32 km/h). The ratio of the tractor weight to the defoliator weight plays an important role in defining acceptable travel speed. Table 1 summarizes the recommended travel speed-to-weight ratio.

Table 1: Speed vs. Weight Ratio

Road Speed	Fully equipped or loaded implement(s) weight relative to towing machine weight
Up to 32 km/h (20 mph)	1 to 1 or less
Up to 16 km/h (10 mph)	2 to 1 or less
Do not tow	more than 2 to 1

PREPARING FOR OPERATION

1. Attach the machine to the tractor
2. Lubricate the machine.
3. Review and follow the pre-operation checklist. See Pre-Operation Check List.
4. Review Transporting the Unit, before transporting to the field.
5. Pull into the field and line up with the first set of rows.
6. Determine the machine parameters that require setting before starting use. See Machine Settings.
7. Close and secure all guards, covers and access doors.

STARTING THE MACHINE

1. Start the tractor engine and run at low idle.
2. Slowly engage the tractor PTO.

IMPORTANT

- Engage and disengage the PTO at low idle engine RPM to minimize shock loads to the drive train.

3. Slowly increase engine speed to the rated PTO speed of 1000 RPM.
4. Put the tractor in gear and proceed down the field.

STOPPING THE MACHINE

1. Take the tractor out of gear.
2. Slowly decrease engine speed down to the idle RPM.
3. Slowly disengage PTO clutch.

IMPORTANT

- Disengage clutch slowly. On newer tractors the PTO brake will stop the shaft in less than one revolution and create shock loads in the drive train if the clutch is not disengaged slowly.

Field Operation *Continued*

4. Stop engine and set park brake before dismounting.

3. Decrease speed if foliage is left on the crown or on the sides (or lower flails).

GROUND SPEED

The defoliator works well at 3 to 6 mph (5 to 10 Km/h) depending on type of job. The operator is responsible for checking the condition of the beets and setting the speed required for the best defoliating. For best results:

1. Increase speed if the beet tops are completely cleaned of foliage.
2. Increase speed if beets are being pulled out of the ground (or raise the flails).

FLAIL PATTERNS

When delivered from the factory, the flail patterns are set as shown in Figure 15. Maintain this pattern at all times.

Do not allow the flails to hit the ground where they might pick up dirt, sticks, stones and other debris that can be thrown out and cause injury. This will also cause rapid wear or breakage.

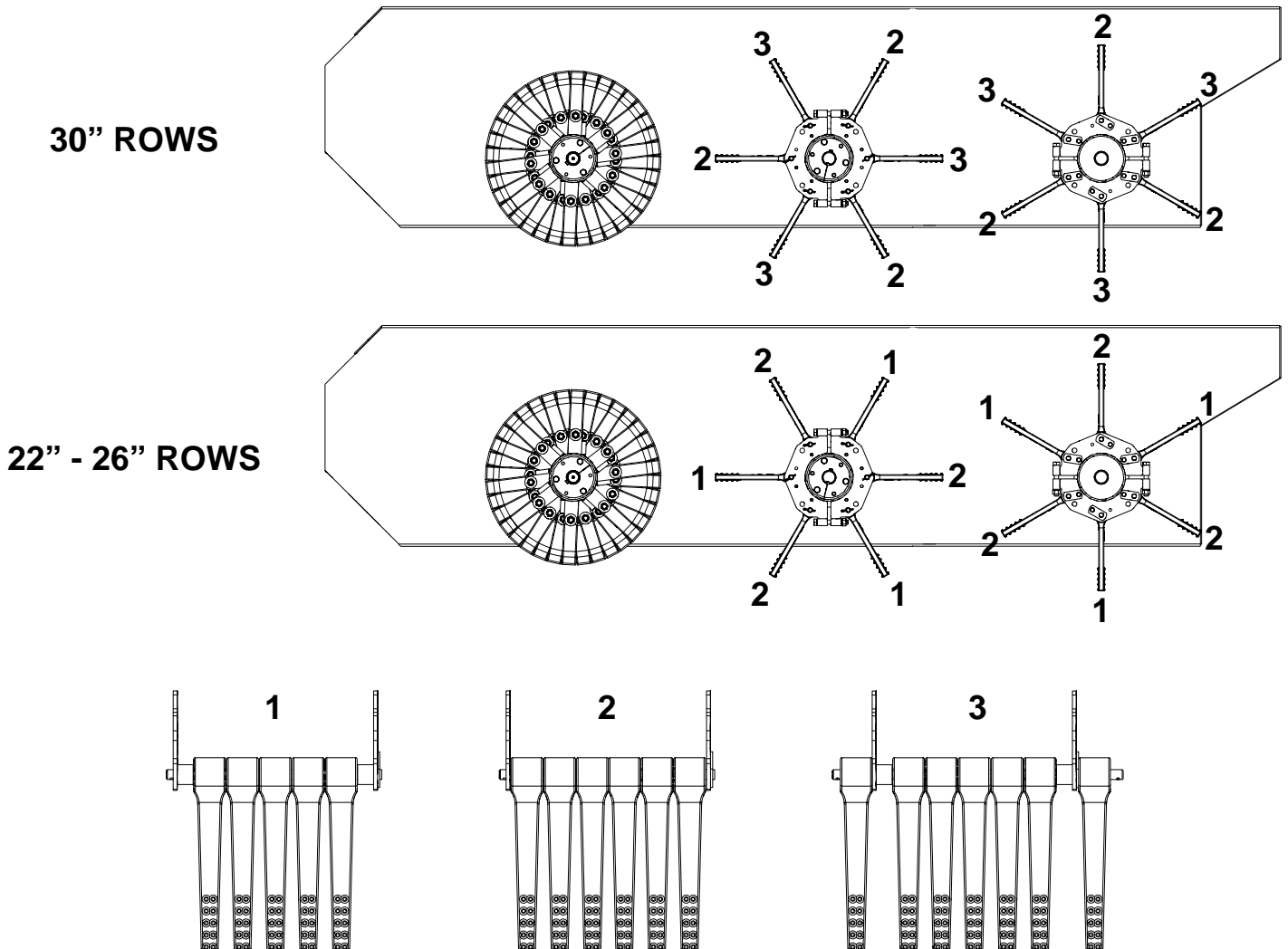

Field Operation *Continued*

OPERATING THE DEFOLIATOR

1. Operate the machine at its rated speed of 1000 rpm at all times. Effective removing of beet tops depends on the flail tip speed. A slower speed can result in foliage being left on the beets.
2. Operate the machine at rated speed at the end of the row until the last drum has passed over the beets.
3. When turning at the end of the field, it may be necessary to skip a machine width of rows before turning back into the field. This will depend on the width of the machine, the width of the headland, and the turning radius of the tractor.
4. Although the driveline may be equipped with an optional constant velocity (CV) joint, turning angles are limited. (See Figure 16.) Do not exceed the working angles. Turn off the machine when making sharp turns.
5. When starting a new field, or when operating conditions change:
 - a. Travel 50 feet into the field.
 - b. Shut off the tractor, place all controls in neutral, set the parking brake, remove the key, and wait for all moving parts to stop.
 - c. Go behind the machine and inspect the beets.
 - d. Check the flail spacing, wheel spacing, machine height, and scalper setting (if so equipped.)
 - e. Adjust as needed.

TURNING

The front universal is equipped with a constant velocity (CV) joint to allow for turning. Although the CV joint allows for sharper turns than a regular driveline, it does have some limitations. Refer to Figure 16.

CV joint angle should not exceed 80 degrees in either operating or standstill condition of the driveline. Larger angles will damage the joint.

The angle should never exceed 35 degrees when the driveline is under full load.

IMPORTANT

- Disengage PTO when making sharp turns.

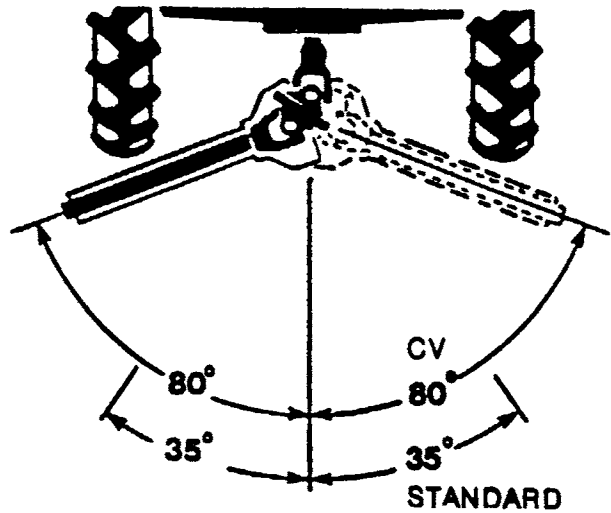

Figure 16. Driveline Angles

HAZARD AREA



WARNING

- Make certain all movement of implement components has stopped before approaching for service.

Stay away from front, side and rear of unit while it is running. Flails can pick up stones, sticks, wire, and other debris and throw it out with enough force to severely injure bystanders.

Keep out of shaded area shown in Figure 17.

Shut down unit and wait for moving parts to stop before approaching.

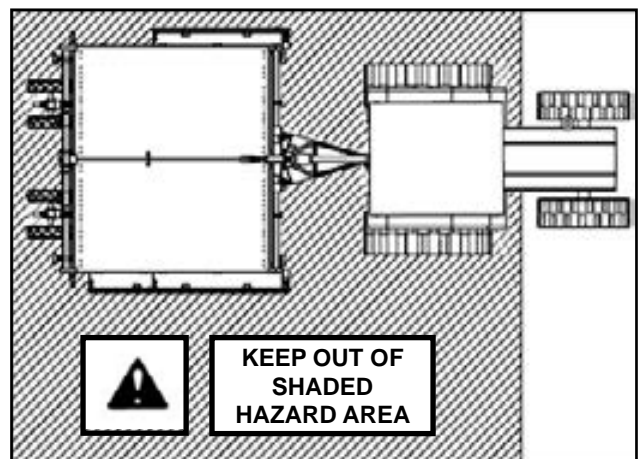

Figure 17. Hazard Area

ADDITIONAL EQUIPMENT (Optional)

REAR STEER

1. Mount rear steer components to back of defoliator body. Refer to Rear Steer Components, and Rear Steer Plumbing Components, in the parts section for hardware and assembly instructions.

2. Attach the sight gauge on defoliator and the hose clamp to adjustable bar. Be sure the sight gauge and hose clamp are aligned when wheels are straight.

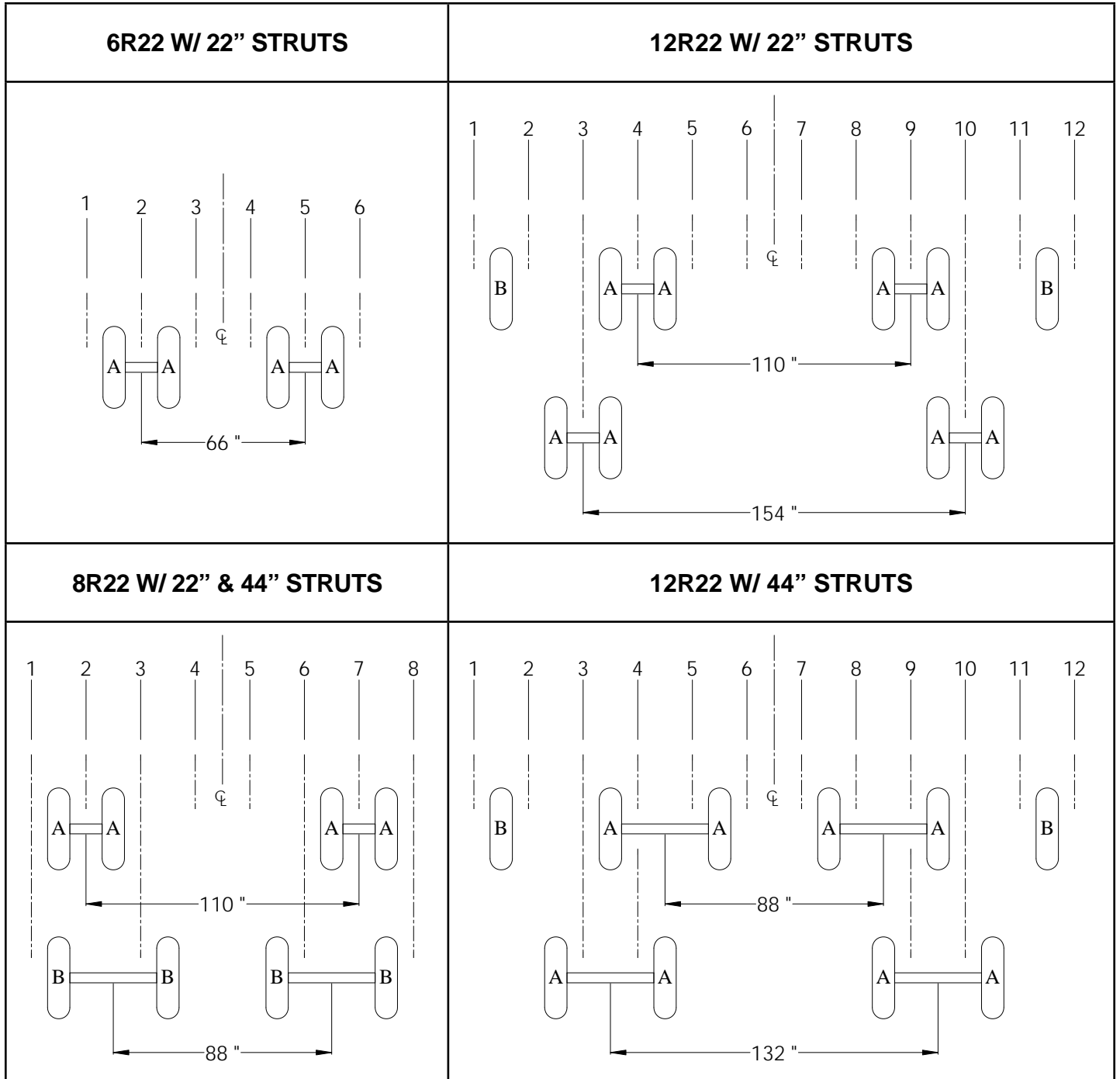

Additional Equipment *Continued*

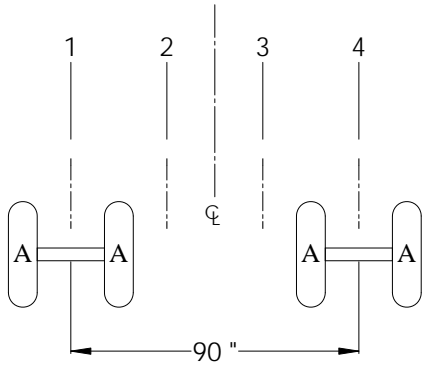
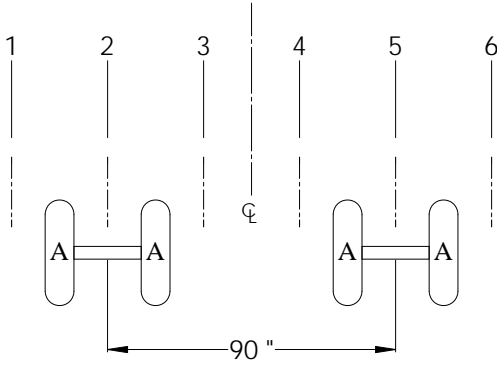
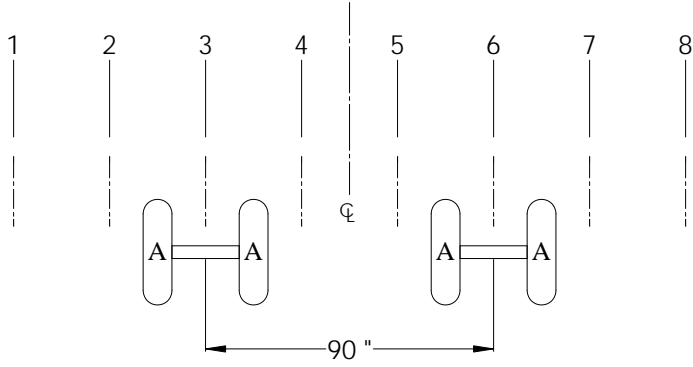
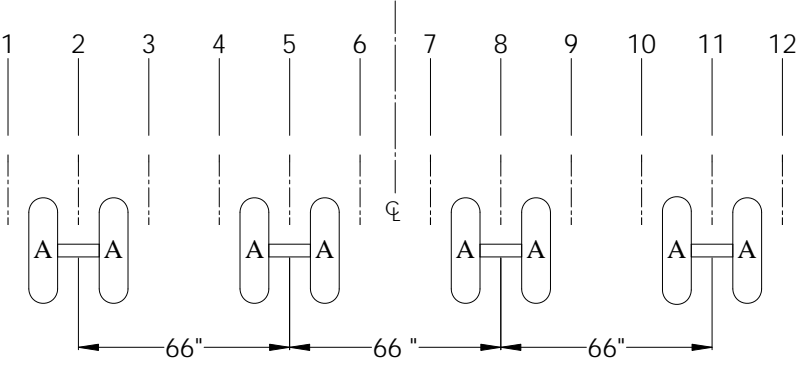
<p>4R30 W/ 30" STRUTS</p>	 <p>Diagram showing 4R30 W/ 30" STRUTS. The diagram illustrates two pairs of struts, each pair labeled 'A'. A horizontal dimension line indicates a 90" distance between the centerlines of the two pairs. Vertical dimension lines are numbered 1 through 4, with a centerline symbol (⌀) between lines 2 and 3.</p>
<p>6R30 W/ 30" STRUTS</p>	 <p>Diagram showing 6R30 W/ 30" STRUTS. The diagram illustrates two pairs of struts, each pair labeled 'A'. A horizontal dimension line indicates a 90" distance between the centerlines of the two pairs. Vertical dimension lines are numbered 1 through 6, with a centerline symbol (⌀) between lines 3 and 4.</p>
<p>8R30 W/ 30" STRUTS</p>	 <p>Diagram showing 8R30 W/ 30" STRUTS. The diagram illustrates two pairs of struts, each pair labeled 'A'. A horizontal dimension line indicates a 90" distance between the centerlines of the two pairs. Vertical dimension lines are numbered 1 through 8, with a centerline symbol (⌀) between lines 4 and 5.</p>
<p>12R22 W/ 22" STRUTS</p>	 <p>Diagram showing 12R22 W/ 22" STRUTS. The diagram illustrates four pairs of struts, each pair labeled 'A'. Horizontal dimension lines indicate a 66" distance between the centerlines of adjacent pairs. Vertical dimension lines are numbered 1 through 12, with a centerline symbol (⌀) between lines 6 and 7.</p>

Additional Equipment *Continued*

RECOMMENDED SCALPER LOCATIONS

(Depending on Additional Equipment)

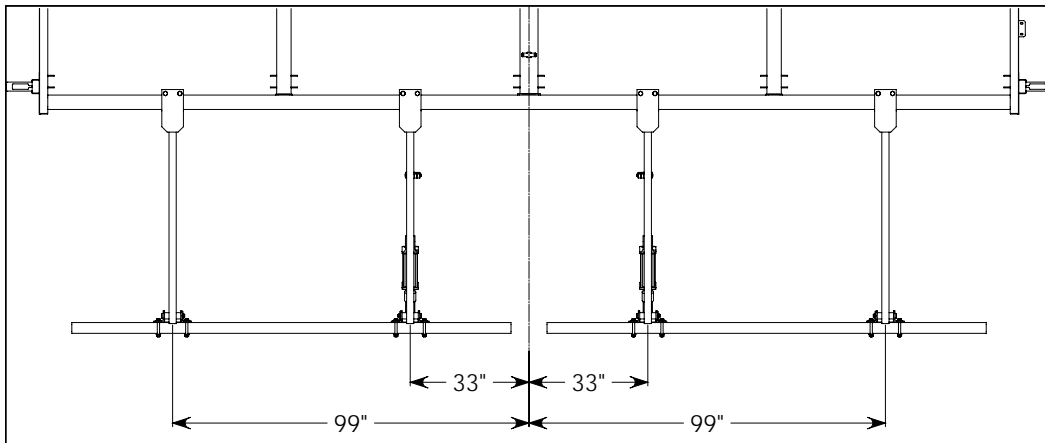

12 ROW 22" SPACING

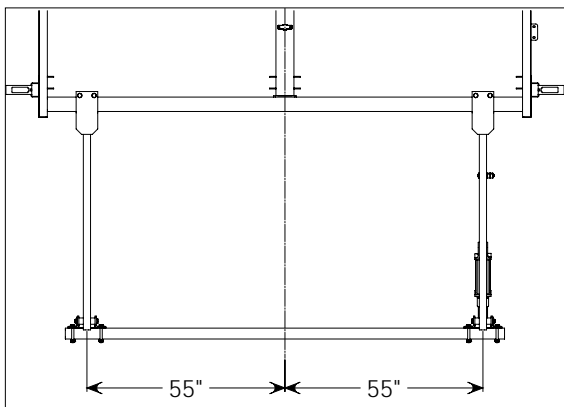

6 ROW 22" SPACING

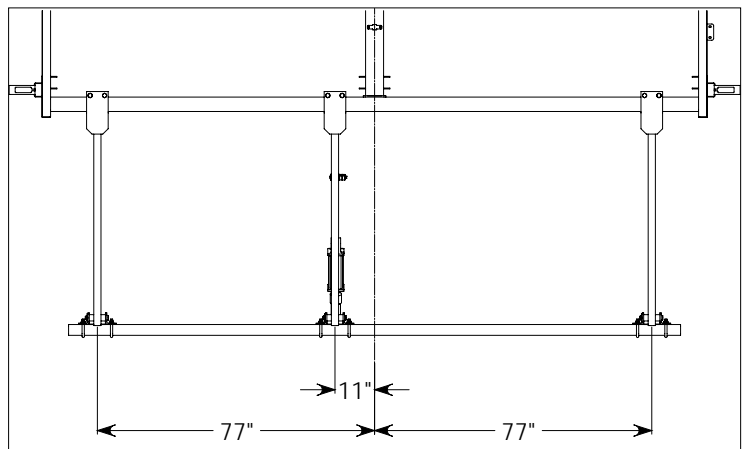

8 ROW 22" SPACING

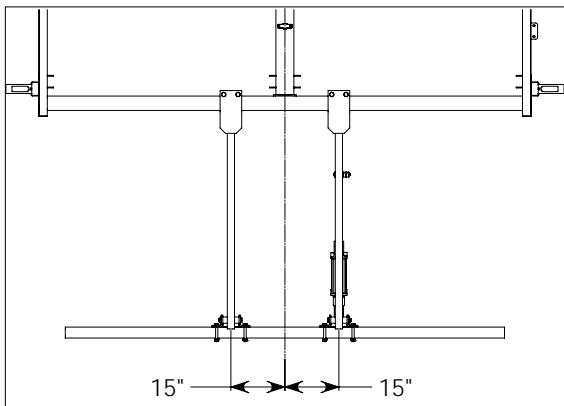

4 ROW 30" SPACING

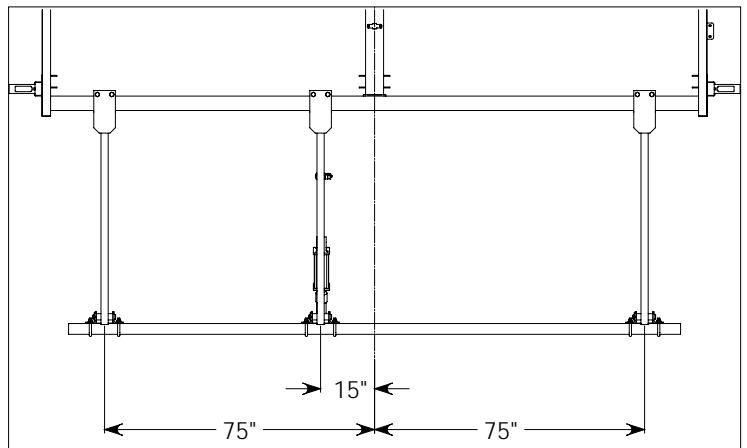

6 ROW 30" SPACING

Additional Equipment *Continued*

STABILIZER STRUTS

1. Mount stabilizer struts to the front of defoliator. Refer to Stabilizer Wheel Components, in the parts section, for assembly.
2. Adjust up and down so the parallel linkage is low in the front in operating position. See Figure 19. This allows maximum upward travel when operating. Pin #10 limits the downward travel of the wheel for road transport. This may be left installed when operating.

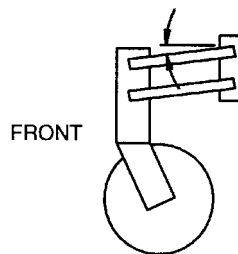

Figure 19a. Stabilizer Strut

STEEL FLAIL UNITS

Adjust seasonally.

NOTE: This is not a field adjustment, but rather a seasonal adjustment.

Set the front drum in either the upper or lower position that best accommodates the variety of sugar beet you are defoliating. The machine is shipped from the factory with the drum in the upper (normal) position. This setting has the steel flail tips 4" higher than the rubber flail tips. The lower setting would put the steel flails only 2" higher than the rubber flails.

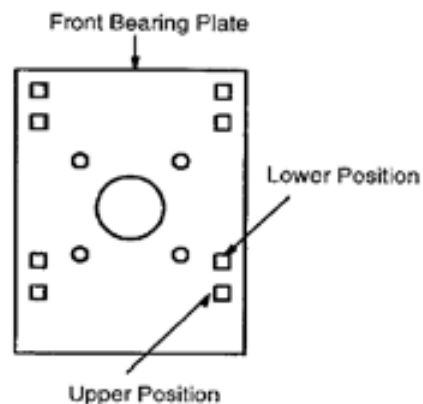

Figure 19b. Steel Flail Adjustment

Additional Equipment *Continued*

DOOR OPENER

The Door Opener is designed to make door opening quick and safe.

To Open Doors :

1. Move lever on Tractor to raise doors.
2. Hook Chain on doors to lock doors up.

To Close Doors :

1. Reverse steps stated above.

IMPORTANT

- Always make sure valve is in neutral position when not controlling door opener, to prevent doors from lifting while defoliating.



Figure 20a. Doors Closed



Figure 20b. Doors Opened

STORAGE



WARNING

- **Keep children and bystanders away from storage area.**

IMPORTANT

- **Store in a dry, level area. Support the base with planks if required.**

After the season's use, inspect all major components of the defoliator. Repair or replace any worn or damaged components to prevent unnecessary downtime at the start of next season.

To assure a long, trouble-free life, follow this procedure when preparing the unit for storage:

1. Open all access doors and canvas covers. Be sure the door locks are in place and secured.



WARNING

- **Equipment may be pictured with covers open for instructional purposes. Never operate equipment with covers open.**

2. Thoroughly wash the machine using a pressure washer to remove all dirt, mud, debris and residue.
3. Inspect the flails, flail assemblies, and drums for damage or entangled material. Repair or replace damaged parts. Remove all entangled material.
4. Inspect all hydraulic hoses, line, couplers and fittings. Tighten any loose fittings. Replace any hose that is badly cut, nicked, abraded, or is separating from the crimped end of a fitting.
5. Inspect drive belts. Replace any that are damaged. Adjust any not to the specified tension.
6. Lubricate all grease fittings. Make sure that all grease cavities have been filled with grease to remove any water residue from the washing.
7. Touch up paint nicks and scratches to prevent rusting.
8. Close and secure access doors and canvas covers.
9. Move to storage area.

10. Select an area that is dry, level and free of debris.

11. Unhook from tractor (see Removing the Defoliator from the Tractor, page 15).

12. Lower the scalpers to the ground for storage.

13. Store the machine in an area away from human activity.

14. Do not allow children to play on or around the stored machine.



Figure 21. Open Covers



Figure 22. Scalper Storage

SERVICE & MAINTENANCE



WARNING

- Keep children and bystanders away from storage area.
- Operators must be instructed in and be capable of the safe operation of the equipment, its attachments, and all controls. Do not allow anyone to operate this equipment without proper instructions.
- Equipment may be pictured with covers open for instructional purposes. Never operate equipment with covers open.
- Keep all persons away from operator control area while performing adjustments, service, or maintenance.
- Make sure shields and guards are properly installed and in good condition. Replace if damaged.
- Never go underneath equipment (lowered to the ground or raised) unless it is properly blocked and secured. Never place any part of the body underneath equipment or between moveable parts even when the engine has been turned off.

Hydraulic system leak down, hydraulic system failures, mechanical failures, or movement of control levers can cause equipment to drop or rotate unexpectedly and cause severe injury or death. Follow Operator's Manual instructions for working underneath and blocking requirements or have work done by a qualified dealer.

- Do not handle blades with bare hands. Careless or improper handling may result in serious injury.

- Before servicing, adjusting, repairing or unplugging, stop tractor engine, place all controls in neutral, set park brake, remove ignition key, and wait for all moving parts to stop.



CAUTION

- Always wear relatively tight and belted clothing to avoid entanglement in moving parts. Wear sturdy, rough-soled work shoes and protective equipment for eyes, hair, hands, hearing, and head; and respirator or filter mask where appropriate.

- Make certain all movement of equipment components has stopped before approaching for service.

LUBRICANTS

Use the Lubrication Service Record (Page 36), to keep a record of all scheduled maintenance.

1. Grease

Use and SAE multi-purpose high temperature grease with extreme pressure (EP) performance. A SAE multi-purpose lithium-based grease is also acceptable.

2. Gearbox Oil

Use an SAE 85W90 gear oil for all operating conditions. Capacity: 2-1/2 U.S. quarts (2.13 liters).

3. Storing Lubricants

Your unit can operate at top efficiency only if clean lubricants are used. Use clean containers to handle all lubricants. Store them in an area protected from dust, moisture, and other contaminants.

GREASING

Use the Lubrication Service Record (Page 31), to keep a record of all scheduled maintenance.

1. Use a hand-held grease gun for all greasing.

2. Wipe grease fitting with a clean cloth before greasing to avoid injecting dirt and grit.

3. Replace and repair broken fittings immediately.

4. If fittings will not take grease, remove and clean thoroughly. Also clean lubricant passageway. Replace fitting if necessary.

Service & Maintenance *Continued*

LUBRICATION SCHEDULE

The period recommended is based on normal operating conditions. Severe or unusual conditions may require more frequent lubrication or oil changes. Refer to Figure 24 for details.

DAILY OR 10 HOURS

1. Lubricate PTO driveline, position A, Figure 22 and Figure 24.
2. Use dipstick to check gearbox oil level.

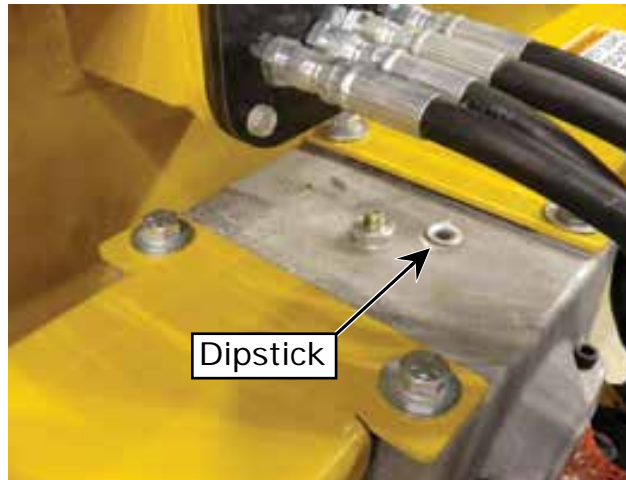

Figure 23. Dipstick

20 HOURS

1. Lubricate bearing zerk with one shot of grease at each B position (13 positions). See Figure 25.
2. Lubricate couplers with 10 shots of grease at each C position.

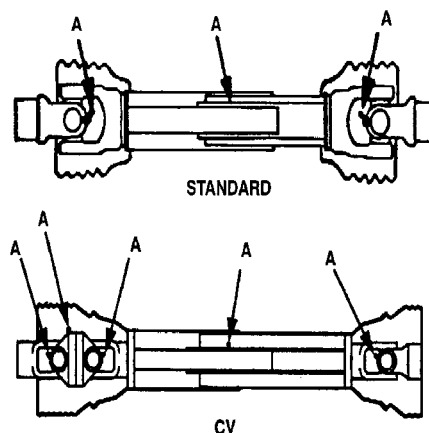
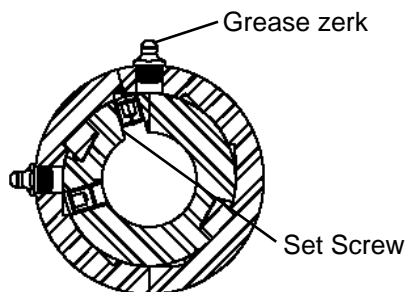

Figure 22. Driveline

For PTO installation, remove grease zerks to gain access to the set screws for locking PTO onto gearbox.

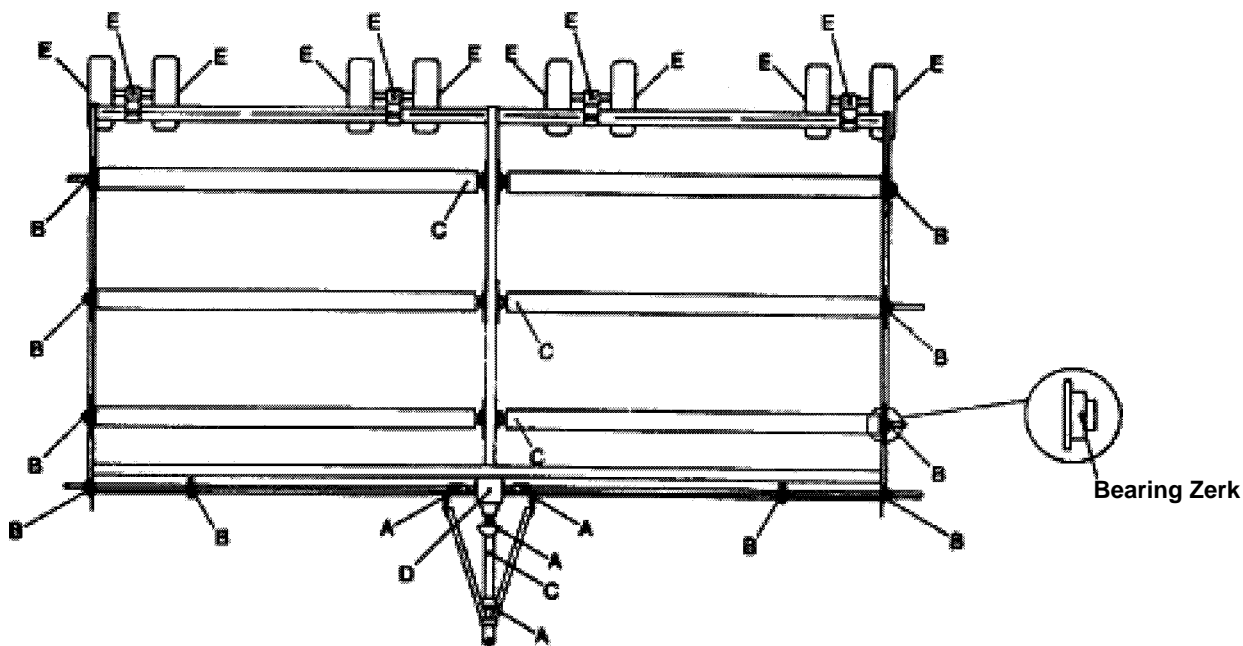

Figure 24. Lubrication Diagram

Service & Maintenance *Continued*

If you remove the flail tube from 9 - 12 row defoliators, thoroughly clean both halves of the drive couplers and apply new grease to all gear teeth. You must remove grease zerk C when replacing the flail tube to allow air to purge from the coupler assembly. Then replace the grease zerk and follow lubrication schedule.

40 HOURS

1. Lubricate PTO driveline (1 location).
2. Lubricate scalper pivot bearings (4 locations each scalper).

ANNUALLY

1. Change gearbox oil.
2. At the start and end of the season, lubricate the scalper and hitch screw jacks (1 location each screw jack).
3. At the start and end of the season, lubricate the trailing wheel pivots - position E (1 location each pivot).

CHANGING GEARBOX OIL

Although the oil in the gearbox never wears out, dust, dirt and moisture can enter through the breather when the oil heats up and cools down during operation. These contaminants must be removed on a regular basis to ensure a long life for the working components. In very dusty or dirty conditions, change the oil twice a year.

To change oil, follow this procedure:

1. Shut off tractor, place all controls in neutral, set parking brake, remove key, and wait for all moving parts to stop.
2. Clear the area of all bystanders.
3. Place a pan under the drain plug. Remove the drain, fill, and level plugs.
4. Allow the gearbox to drain for 10 minutes.
NOTE: It is best to drain the oil when the gearbox is hot to remove the most contaminants. Use a stiff probe to clean the breather hole in the fill plug.
5. Install and tighten the drain plug.

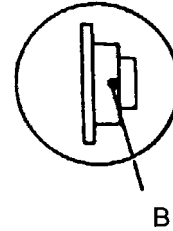

Figure 25. Position B

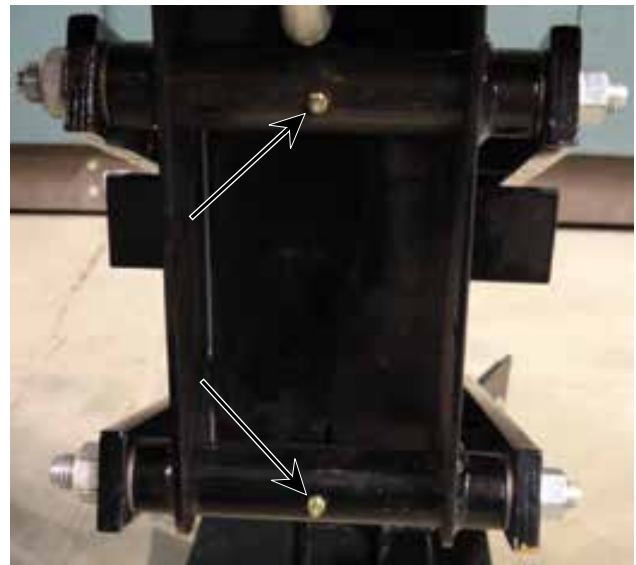

Figure 26. Scalper Pivot Bearings

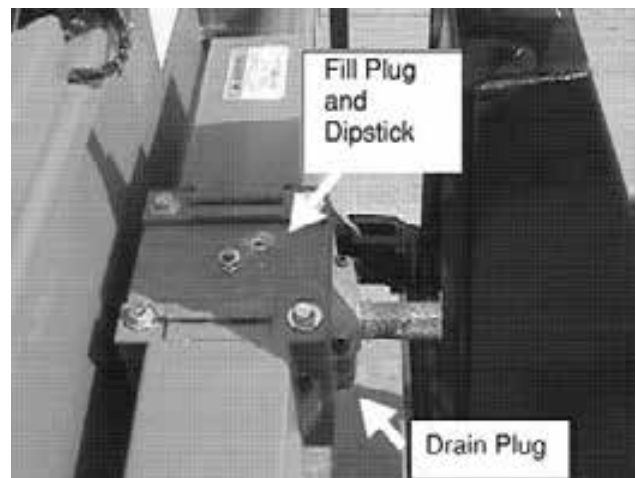

Figure 27. Gearbox, Fill & Drain Plugs

6. Dispose of the used oil in an approved container.
7. Add 1 quart of SAE 85W90 gear oil through the fill plug. Check, using the dipstick.
8. Install and tighten the level and fill plugs

Service & Maintenance *Continued*

WHEEL SPACING

The rear wheels are designed to move along the frame to align them with the rows. To adjust the spacing of the wheels, follow this procedure:

1. Shut off tractor, place all controls in neutral, set parking brake, remove key, and wait for all moving parts to stop.
2. Clear the area of all bystanders.
3. Use a jack with sufficient capacity to lift the frame. Place planks under the jack for extra support if required.
4. Measure from the centerline of the machine to determine the required spacing. Mark the position on the frame.
5. Lift the frame until the wheels have cleared the ground.
6. Loosen the wheel assembly mounting bolts.

FLAIL SPACING

The flails are mounted to an assembly or head that clamps to the rotating drum. To adjust the head position, follow this procedure:

1. Shut off tractor, place all controls in neutral, set parking brake, remove key, and wait for all moving parts to stop.
2. Clear the area of all bystanders.
3. 3. Disconnect driveline from the tractor.
4. 4. Open the canvas covers.
5. 5. Measure from the center line of the machine to determine the required spacing.
6. 6. Loosen the assembly clamping nuts.



CAUTION

■ Equipment may be pictured with covers open for instructional purposes. Never operate equipment with covers open.



Figure 28. Wheel Mounting Bolts (Small Tires)

7. Slide the assembly along the frame to the required position.
8. Tighten the mounting bolts to their specified torque levels.
9. Lower frame and remove jack.



Figure 29. Rubber Flails

7. Slide or tap assembly to the desired position
8. Tighten clamping bolts to their specified torque level.
9. Repeat with other head assemblies as required.
10. Close and secure canvas covers.
11. Attach driveline to the tractor.

Service & Maintenance *Continued*

FLAIL REPLACEMENT

The flails swing on pins through the head. When replacing damaged or broken flails, follow this procedure:

1. Shut off tractor, place all controls in neutral, set parking brake, remove key, and wait for all moving parts to stop.
2. Clear the area of all bystanders.
3. Disconnect driveline from tractor.
4. Open canvas covers.
5. Remove the mounting bolt and cotter pin.
6. Slide pin out to release flails.
7. Replace with new flail. Be sure to assemble the spacers and bushings in their appropriate positions. See Parts Section and Flail Patterns.
8. Re-install bolt and cotter pin. Tighten bolt to specified torque.
9. Repeat with other flails as required.



CAUTION

■ Equipment may be pictured with covers open for instructional purposes. Never operate equipment with covers open.

10. Remove 5/8 locknut.
11. Tap out 5/8 x 3 1/2 carriage bolt.
12. Remove flails and bushing.
13. Install new bushing and flail.
14. Install bolt and nut.
15. Tighten bolt and nut.
16. Close and secure access doors and covers and install secure guards before resuming work.
17. Attach driveline to tractor.



Figure 30. Steel Flails



Figure 31. Flail Assembly

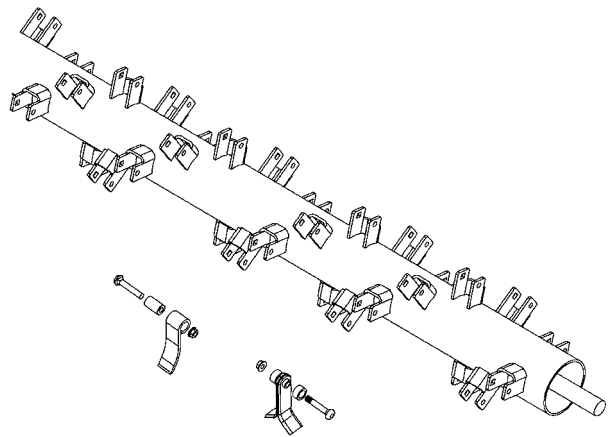

Figure 32. Steel Flails

Service & Maintenance *Continued*

BELT TENSION

The drive belts transmit power to turn the drums and flails. Belt tension must be maintained to insure proper machine performance. Overtightening will cause belts and pulleys to run hot; loose belts will allow slipping. Either condition will cause rapid wear and failure.

When the machine is new, or after installing new belts, tension should be checked and adjusted as required every 4 to 5 hours for 2 to 3 days - until belts have "run in."

To check belt tension, follow this procedure:

1. Shut off tractor, place all controls in neutral, set parking brake, remove key, and wait for all moving parts to stop.
2. Clear the area of all bystanders.
3. Disconnect driveline from tractor.
4. Open belt access doors and fasten prop rods.
5. Align sight gauge with spring washer to set proper belt tension. Do not over-tighten.
6. Close and secure access doors and covers and install secure guards before resuming work.
7. Attach driveline to tractor.

BEARING LOCK COLLARS

Bearings are held on the shaft by locking collars. Always install locking collars in the direction of shaft rotation.

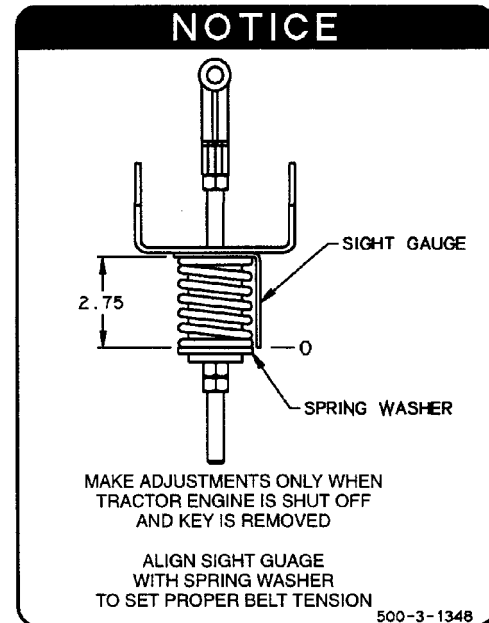

Figure 33. Belt Tension Gauge

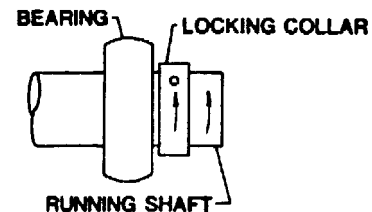

Figure 34. Locking Collar

Service & Maintenance *Continued*

BELT REPLACEMENT

Belts must be maintained in good condition at the proper tension to obtain expected performance. When they fray or separate, they must be replaced. Do not use belt dressings at any time. Keeping the belts at the required tension will prevent slippage.

To replace belts, follow this procedure:

1. Shut off tractor, place all controls in neutral, set parking brake, remove key, and wait for all moving parts to stop.
2. Clear the area of all bystanders.
3. Disconnect driveline from tractor.
4. Open the belt access doors.
5. Loosen the bolts on the belt tensioner arm.

FLAIL TUBE HANGER BEARING

Flail tube hanger bearings on 6 row, 9 row, and 12 row: 30" steel machines require annual maintenance (lubrication) and inspection.

Follow this procedure:

1. Shut off tractor, place all controls in neutral set parking brake, remove key, and wait for all moving parts to stop.
2. Clear the area of all bystanders.
3. A rolling floor jack is required to slide the flail tube away from the bearing hanger plate for annual greasing and inspection.
4. Locate the bearing. The hanger bearing is located on the tail shaft flail tube (tube without a drive sheath attached).
5. Support center hanger plate with floor jack.
6. Remove the four 5/8 x 1 -1/2 carriage bolts from the tail shaft bearing plate and 3/4 hanger plate bolt.
7. Lower and move back until tubes can be separated.
8. Remove the bearing protector lock/collar.

6. Remove belt.
7. Install new belt. Do not force belt over pulley and damage the cords.

IMPORTANT

Use only genuine Alloway replacement parts

8. Tension the belt. See Belt Tension, page 34.
9. Check that all pulleys are aligned.
10. Check the tension of the new belt every 4 to 5 hours the first 2 or 3 days of operation. Adjust as required.
11. Close and secure access doors and covers and install secure guards before resuming work.
12. Attach driveline to the tractor.

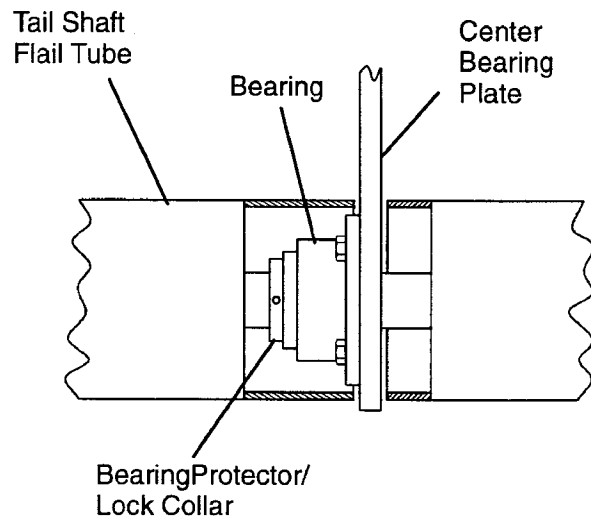

Figure 35. Hanger Bearings

9. Wipe the bearing clean and inspect the grease seal.
10. Lubricate bearing zerk with 3 to 4 shots of grease.
11. Slide tube back onto coupler and re-attach tail shaft bearing.
12. Repeat for all three hanger bearings.

NOTE: Do not lube new bearings.

Service & Maintenance *Continued*

SCALPERS

Scalpers must be set for each crop and operating condition. The scalper should be set to cut off only the green portion of the beet.

Set the shoe angle:

- a. Loosen bolts (1) and (2), Figures 36a, 36b & 36c.
- b. Move shoe to desired angle.
- c. Tighten bolts to specified torque level.

KNIFE SCALPER

To adjust the knife scalper, follow this procedure:

1. Set the cutting edge of the knife at the lowest portion of the assembly to prevent skipping over the beets.
2. Set knife height and angle:
 - a. Loosen bolts (3) and (4), Figures 36a & 36b.
 - b. Move knife to desired height and angle.
 - c. Tighten bolts to specified torque level.
3. Down pressure position:
 - a. Increase spring tension to decrease skipping (5).
 - b. Decrease spring tension if scalper pulls beets out of ground.
4. Float position:
 - a. Increase spring tension for less pressure on shoe (5).
 - b. Decrease spring tension for more pressure on shoe.

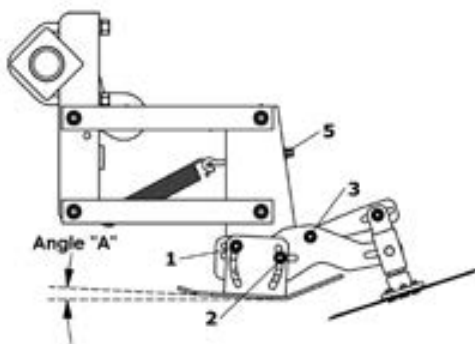

Figure 36c. Circular Scalper

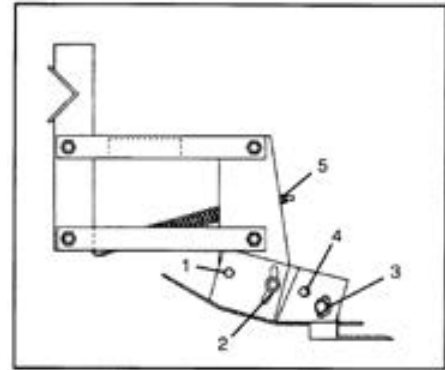

Figure 36a. Knife Scalper (Down Pressure)

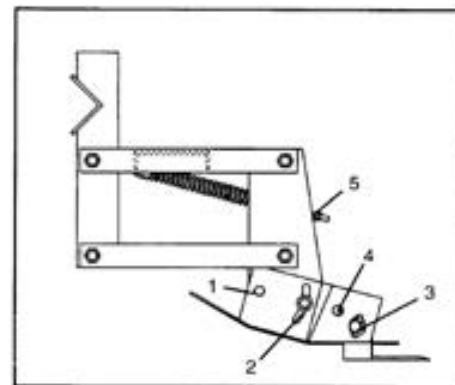

Figure 36b. Knife Scalper (Float)

CIRCULAR SCALPER

To adjust the circular scalper, follow this procedure:

1. Set the angle of the assembly so the cutting edge of the disc is the lowest portion of the scalper. This will prevent skipping the beets.

IMPORTANT

The shoe angle "A" should be set as small as possible without pushing beets over.

2. Set disc height:
 - a. Move disc assembly to desired height.
 - b. Tighten bolts (1), (2) and (3) to specified torque level.

IMPORTANT

Do not set disc to run on or below ground level.

3. Use the spring bolt to set spring tension (5).
 - a. Increase tension to minimize skipping.
 - b. Decrease tension if disc pulls beet over.

TROUBLE SHOOTING

The Alloway Beet Defoliator uses rubber or steel flails on drums to remove foliage from the tops of sugar beets. It is a simple and reliable system that requires minimal maintenance. The following table lists problems, causes, and solutions that you may

encounter. If you encounter a problem that is difficult to solve even after reading through this table, please call your local Alloway dealer. When calling, please have this manual and your unit's serial number ready.

PROBLEM	CAUSE	SOLUTION
Drums won't turn	Tractor PTO defective	Repair tractor PTO
	Broken cross shaft or drive coupler on central hanger bearing	Replace (9 or 12 row units only)
Rapid belt wear	Machine plugged	Unplug machine
	Pulleys out of alignment	Align pulleys
	Loose or overtightened belts	Adjust belt tension
	Overloaded/Running too low	Raise unit or slow down
Flails breaking	Machine too low	Raise machine
	Hitting rocks or other debris	Clean field better before planting
Tires don't turn	Mud buildup	Adjust tire pressure to 15-20 psi
Beet crown not clean	Machine too high	Lower the machine
	Flails broken	Replace broken flails
	Traveling too fast	Slow down
	Running slow (tractor)	Increase speed to rated PTO RPM
	Need a scalper	Install and set scalper
	Scalper bounces	Increase scalper spring tension
Beets are pulled out of the ground	Machine too low	Raise machine
	Machine too slow	Increase ground speed
	Scalper pulling beets out of ground	Adjust scalper
Defoliator vibrates	Driveline doesn't telescope	Remove, disassemble, and clean telescoping joint
	Flail tube out of balance	Balance tube



PARTS INDEX

BEET DEFOLIATOR

Frame Components	42 - 45
Belt Drive Components	46 - 49
Flail Tube Components	50 - 53
Belt Cover Components	54
Flail Components	55
Top Cover Components	56 - 57
Rear Strut Components	58 - 68
Scalper Components	69 - 71
Scalper Toolbar Components	72 - 73
Stabilizer Wheel Components	74 - 75
Hub & Spindle Components	76 - 77
Row Finder Components	78 - 87
Row Finder Parallel Link Mount Components	88 - 91
Rear Steer Hydraulic Components	92
Row Finder Hydraulic Components	93
Scalper Hydraulic Components	94
Door Opener Hydraulic Components	95
Hydraulic Strut Components	96 - 99
Hardline Components	100 - 101
PTO Drive Shaft Components	102 - 105
Gear Box Components	106
Light Kit Components	107
Hitch Components	108 - 109
Hitch Hydraulic Components	110

FRAME COMPONENTS (630, 822)

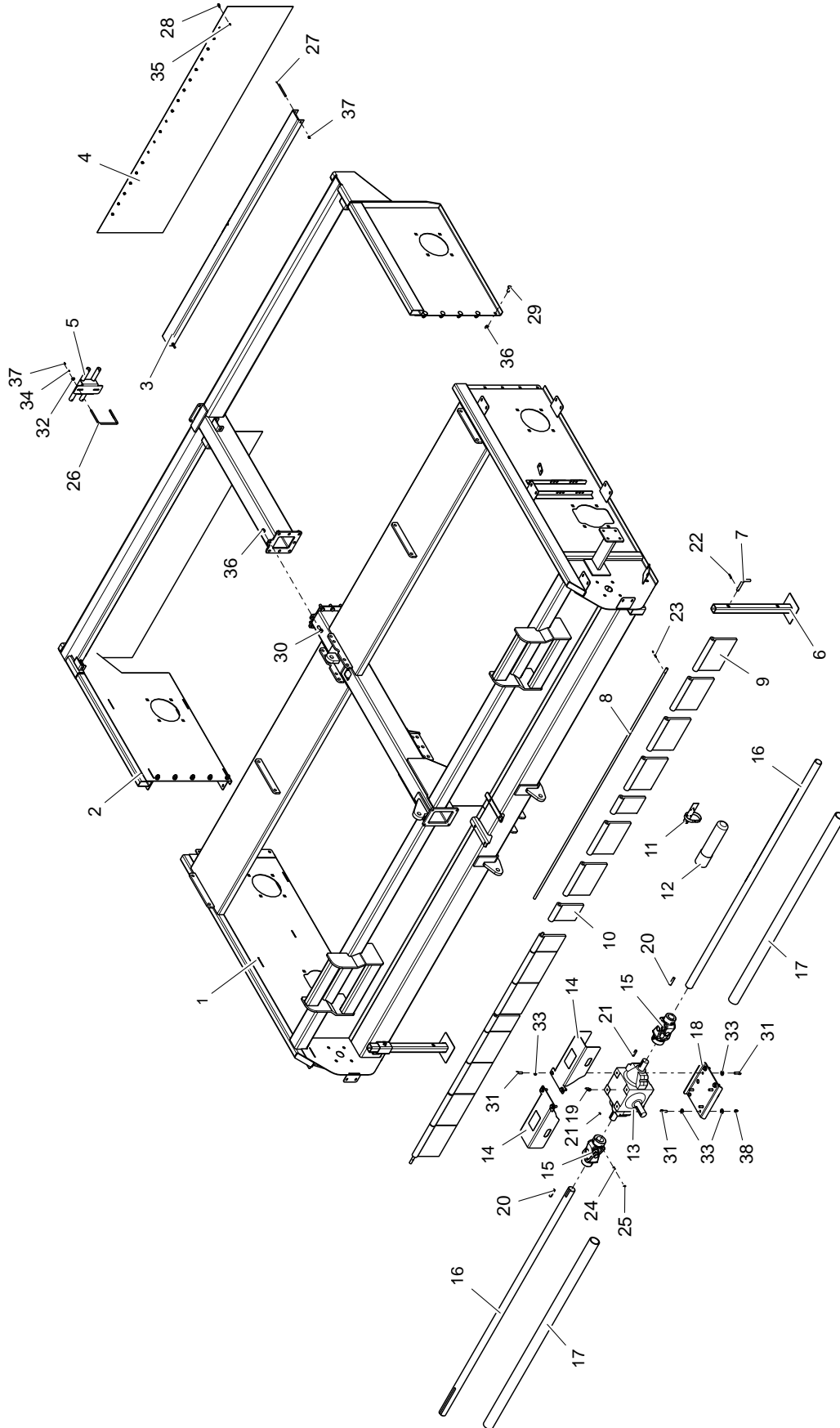

FRAME COMPONENTS (630, 822)

ITEM NO.	PART NUMBER	DESCRIPTION	QTY.
1	500-2-1345	FRONT BODY WELD (630-822)	1
2	500-2-1349	REAR BODY WELD (630-822)	1
3	500-3-1292	CROSS CHANNEL (630-822)	2
4	500-3-0737	REAR FLAP (630-822)	2
5	500-2-1176	CYLINDER STOP STORAGE BRACKET	1
6	500-2-0531	PARKING STAND	2
7	505-3-0279	PIN, PARKING STAND	2
8	500-3-1140	FLAP ROD (630-822)	2
9	505-3-1089	FLAP SHIELD, 12"	12
10	505-3-1097	FLAP SHIELD, 6"	4
11	100-3-3958	MANUAL TUBE CLAMP	1
12	100-3-3957	MANUAL STORAGE TUBE	1
13	903-15399	GEARBOX (600 SERIES)	1
14	500-2-0537	U-JOINT SHIELD	2
15	903-05038	U-JOINT ASSY, 1-3/4" TO 2" (44R)	2
16	500-3-1661	CROSS SHAFT (630-822)	2
17	500-3-1660	CROSS SHAFT SHIELD (630-822)	2
18	500-3-2778	GEARBOX MOUNT PLATE	1
19	905-03283	STRAIGHT ADAPTER, 8FP x 8MP	1
20	500-3-1662	KEY, 1/2 x 1/2 x 2-1/2	2
21	100-3-3333	KEY, 3/8 x 3/8 x 2	2
22	900-25004	HAIR CLIP PIN, 1/8"	-
23	900-23043	COTTER PIN, 3/16 x 1-1/2	-
24	900-16255	SETSCREW, 3/8 NC x 3/4	-
25	900-06270	NUT, JAM 3/8 NC	-
26	900-35000	U-BOLT, 3/8 NC x 6 x 5	-
27	900-01139	BOLT, 3/8 NC x 5-1/2	-
28	900-03419	WIZLOCK BOLT, 5/16 x 3/4	-
29	900-01784	CARRIAGE BOLT, 5/8 NC x 1-1/2	-
30	900-01341	BOLT, 5/8 NC x 1-1/2	-
31	900-01225	BOLT, 1/2 NC x 1-1/2	-
32	900-11033	WASHER, FLAT 3/8	-
33	900-11035	WASHER, FLAT 1/2	-
34	900-11011	WASHER, LOCK 3/8	-
35	900-06003	NUT, 5/16 NC	-
36	900-06013	NUT, 5/8 NC	-
37	900-06005	NUT, 3/8 NC	-
38	900-06009	NUT, 1/2 NC	-
39	905-21448	CYLINDER DEPTH STOP 1"	6
40	905-21449	CYLINDER DEPTH STOP 1/2"	6
41	905-21450	CYLINDER DEPTH STOP 1/4"	-
-	500-1-0301	CYLINDER DEPTH STOP KIT - INCLUDES : #5, #26, #32, #34, #37, #39, #40	-

FRAME COMPONENTS (830, 1222)

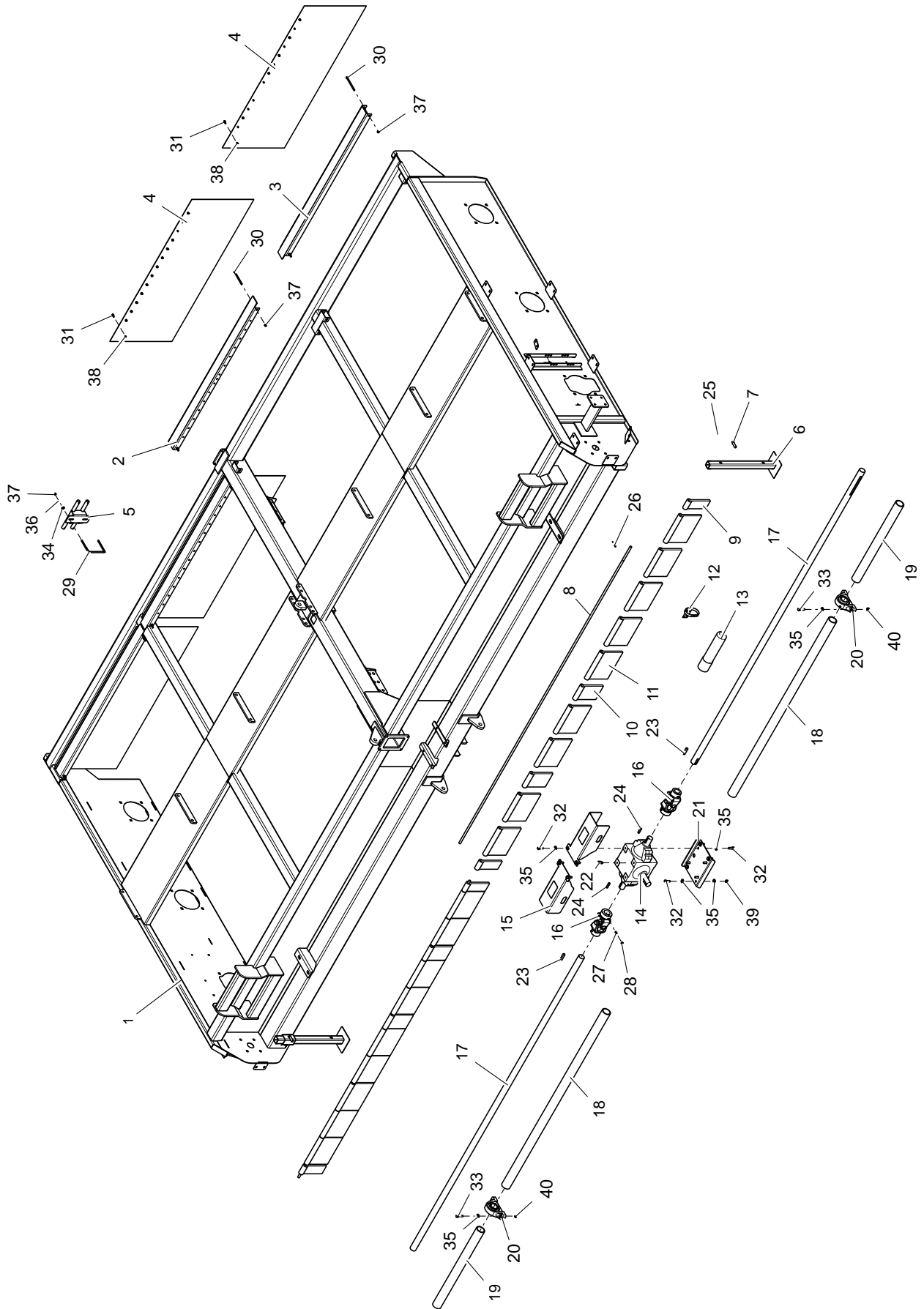

FRAME COMPONENTS (830, 1222)

ITEM NO.	PART NUMBER	DESCRIPTION	QTY.
1	500-2-1344	BODY WELD (1222)	1
	500-2-1405	BODY WELD (830)	
2	500-3-2701	REAR CROSS CHANNEL (1222) - RH	2
	500-3-2916	REAR CROSS CHANNEL (830) - RH	
3	500-3-2697	REAR CROSS CHANNEL (1222) - LH	2
	500-3-2920	REAR CROSS CHANNEL (830) - LH	
4	500-3-0969	REAR FLAP (1222)	4
	500-3-2915	REAR FLAP (830)	
5	500-2-1176	CYLINDER STOP STORAGE BRACKET	1
6	500-2-0531	PARKING STAND	2
7	505-3-0279	PIN, PARKING STAND	2
8	500-3-1142	ROD, FLAPS (1222)	2
	500-3-2524	ROD, FLAPS (830)	
9	505-3-0868	FLAP SHIELD, 3-1/2"	4
10	505-3-1097	FLAP SHIELD, 6"	4
11	505-3-1089	FLAP SHIELD, 12"	18
12	100-3-3958	MANUAL TUBE CLAMP	1
13	100-3-3957	MANUAL STORAGE TUBE	1
14	903-15399	GEARBOX (600 SERIES)	1
15	500-2-0537	U-JOINT SHIELD	2
16	903-05038	U-JOINT ASSY, 1-3/4" TO 2" (44R)	2
17	500-3-0988	CROSS SHAFT (1222)	2
	500-3-2908	CROSS SHAFT (830)	
18	500-3-0867	CROSS SHAFT SHIELD (1222) - LONG	2
	500-3-2909	CROSS SHAFT SHIELD (830) - LONG	
19	500-3-0866	CROSS SHAFT SHIELD (830/1222) - SHORT	2
20	901-01142	BEARING, PILLOW BLOCK, 2"	2
21	500-3-2778	GEARBOX MOUNT PLATE	1
22	905-03283	STRAIGHT ADAPTER, 8FP x 8MP	1
23	500-3-1662	KEY, 1/2 x 1/2 x 2-1/2	2
24	100-3-3333	KEY, 3/8 x 3/8 x 2	2
25	900-25004	HAIR CLIP PIN, 1/8"	-
26	900-23043	COTTER PIN, 3/16 x 1-1/2	-
27	900-16255	SETSCREW, 3/8 NC x 3/4	-
28	900-06270	NUT, JAM 3/8 NC	-
29	900-35000	U-BOLT, 3/8 NC x 6 x 5	-
30	900-01139	BOLT, 3/8 NC x 5-1/2	-
31	900-03419	WIZLOCK BOLT, 5/16 x 3/4	-
32	900-01225	BOLT, 1/2 NC x 1-1/2	-
33	900-01229	BOLT, 1/2 NC x 2	-
34	900-11033	WASHER, FLAT 3/8	-
35	900-11035	WASHER, FLAT 1/2	-
36	900-11011	WASHER, LOCK 3/8	-
37	900-06005	NUT, 3/8 NC	-
38	900-06003	NUT, 5/8 NC	-
39	900-06009	NUT, 1/2 NC	-
40	900-06143	NUT, SPIRALOCK, 1/2 NC	-
41	905-21448	CYLINDER DEPTH STOP 1"	6
42	905-21449	CYLINDER DEPTH STOP 1/2"	6
43	905-21450	CYLINDER DEPTH STOP 1/4"	-
-	500-1-0301	CYLINDER DEPTH STOP KIT - INCLUDES : #5, #29, #34, #36, #37, #41, #42	-

BELT DRIVE COMPONENTS - RH (630, 822, 922, 1222)



BELT DRIVE COMPONENTS - RH (630, 822, 922, 1222)

ITEM NO.	PART NUMBER	DESCRIPTION	QTY.
1	500-3-1202	BEARING PLATE - SHORT	2
2	500-3-0990	PLASTIC BEARING SHIELD	3
3	901-01282	BEARING, 1-15/16"	3
4	500-3-1201	BEARING PLATE - TALL	1
5	500-3-1062	HUB, 1-15/16" (TYPE E)	2
6	903-08439	PULLEY, 5/5V-1400 (TYPE E)	1
7	100-3-3331	KEY, 1/2 X 1/2 X 3	4
8	903-01436	BELT, 5/5V-2500	1
9	500-3-4607	BEARING PLATE, 2"	1
10	901-01428	2" ECCENTRIC COLLAR BEARING	1
11	903-08438	PULLEY, 5/5V-9.75 (TYPE E)	1
12	500-2-1386	PIVOT BASE - TALL	2
13	500-2-0777	PULLEY, SMOOTH	3
14	500-3-1063	HUB, 2", (TYPE E) W/ KEYWAY & W/ BOLTS	1
15	903-08390	PULLEY, 5/5V-850 (TYPE E)	1
16	903-08391	PULLEY, 5/5V-1320 (TYPE E)	1
17	500-3-1060	HUB, 2 (TYPE E)	1
18	500-3-1248	PULLEY, FLAT	1
19	500-3-1221	BRACKET, SPRING MOUNT - LONG	1
20	500-3-1222	BRACKET, SPRING MOUNT - SHORT	1
21	500-3-1250	TENSIONER ROD, 1/2NC	2
22	500-3-1255	SIGHT GAUGE	2
23	905-14005	SPRING	2
24	500-2-0580	SPRING SUPPORT	2
25	500-2-1383	PIVOT ARM	2
26	500-3-1246	WASHER, PULLEY SPACER	4
27	901-01122	BUSHING, OILITE	4
28	901-01008	BEARING, 4-BOLT FLANGE, 2"	1
29	500-2-1384	PIVOT BASE - SHORT	1
30	500-3-1247	CLEVIS (ZINC PLATED CLEAR)	2
31	903-01426	BELT, 5/5V-950	1
32	900-01367	BOLT, 5/8 NC X 5-1/2	-
33	900-01363	BOLT, 5/8 NC X 4-1/2	-
34	900-01345	BOLT, 5/8 NC X 2	-
35	900-01223	BOLT, 1/2 NC X 1-1/4	-
36	900-01784	CARRIAGE BOLT, 5/8 NC X 1-1/2	-
37	900-01221	BOLT, 1/2 NC X 1	-
38	900-01339	BOLT, 5/8 NC X 1-1/4	-
39	900-01225	BOLT, 1/2 NC X 1-1/2	-
40	900-01753	CARRIAGE BOLT, 1/2 NC X 2	-
41	900-06013	NUT, 5/8 NC	-
42	900-06009	NUT, 1/2 NC	-
43	900-06143	NUT, SPIRALOCK, 1/2 NC	-
44	900-11088	WASHER, 5/8 (SAE)	-
45	900-11013	WASHER, LOCK, 1/2	-
46	900-11015	WASHER, LOCK, 5/8	-
47	900-11035	WASHER, 1/2	-

BELT DRIVE COMPONENTS - LH (630, 822, 922, 1222)

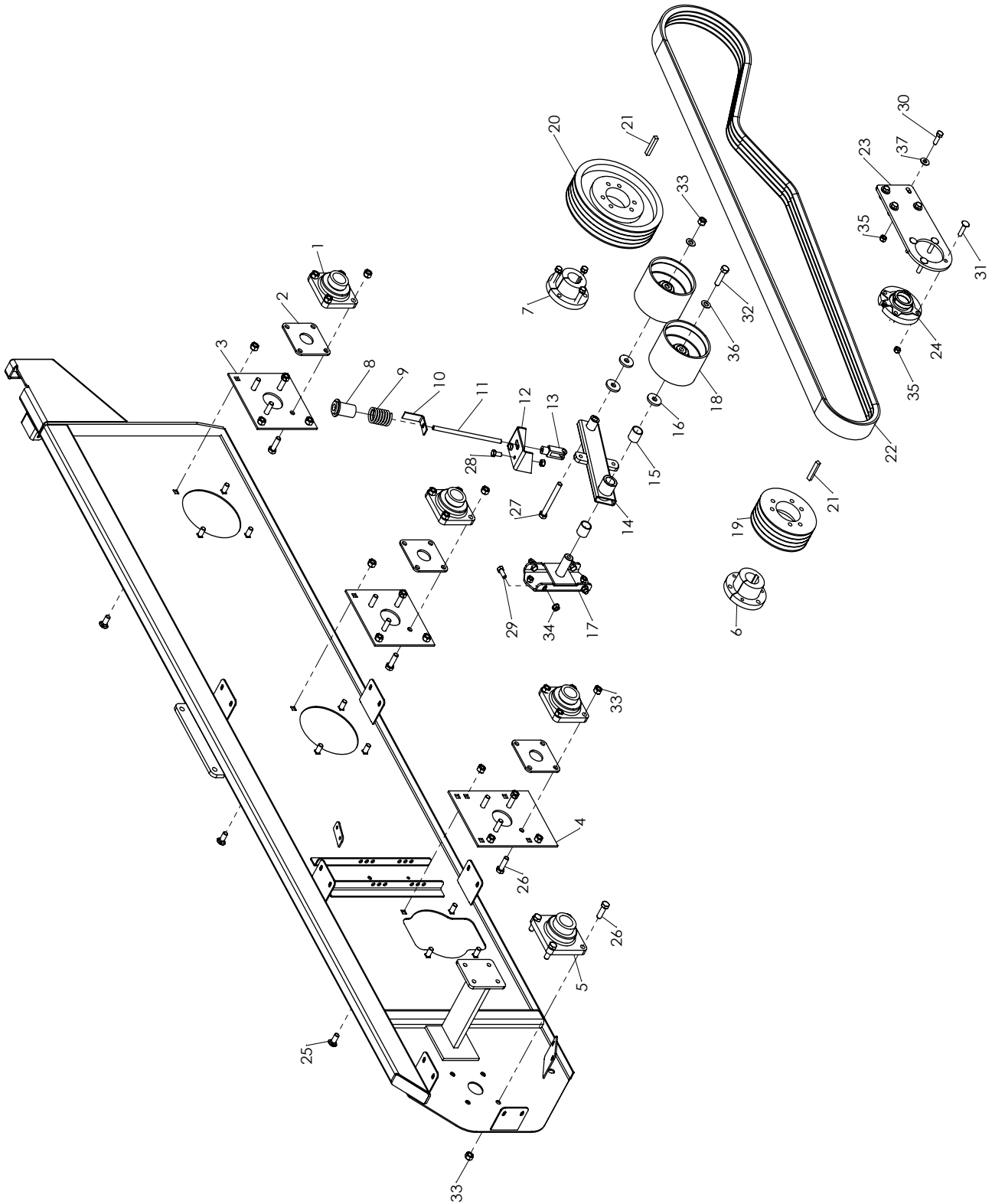

BELT DRIVE COMPONENTS - LH (630, 822, 922, 1222)

ITEM NO.	PART NUMBER	DESCRIPTION	QTY.
1	901-01282	BEARING, 1-15/16"	3
2	500-3-0990	PLASTIC BEARING SHIELD	3
3	500-3-1202	BEARING PLATE - SHORT	2
4	500-3-1201	BEARING PLATE - TALL	1
5	901-01008	BEARING, 4-BOLT FLANGE, 2"	1
6	500-3-1060	HUB, 2 (TYPE E)	1
7	500-3-1062	HUB, 1-15/16" (TYPE E)	1
8	500-2-0580	SPRING SUPPORT	1
9	905-14005	SPRING	1
10	500-3-1255	SIGHT GAUGE	1
11	500-3-1250	TENSIONER ROD, 1/2NC	1
12	500-3-1222	BRACKET SPRING MOUNT - SHORT	1
13	500-3-1247	CLEVIS (ZINC PLATED CLEAR)	1
14	500-2-1383	PIVOT ARM	1
15	901-01122	BUSHING, OILITE	2
16	500-3-1246	WASHER, PULLEY SPACER	3
17	500-2-1384	PIVOT BASE - SHORT	1
18	500-2-0777	PULLEY, SMOOTH	2
19	903-08389	PULLEY, 4/5V-850 (TYPE E)	1
20	903-08388	PULLEY, 4/5V-1320 (TYPE E)	1
21	100-3-3331	KEY, 1/2 X 1/2 X 3	2
22	903-01424	BELT, 4/5V-1700	1
23	500-3-4607	BEARING PLATE, 2"	1
24	901-01428	2" ECCENTRIC COLLAR BEARING	1
25	900-01784	CARRIAGE BOLT, 5/8 NC X 1-1/2	-
26	900-01345	BOLT, 5/8 NC X 2	-
27	900-01367	BOLT, 5/8 NC X 5-1/2	-
28	900-01221	BOLT, 1/2 NC X 1	-
29	900-01223	BOLT, 1/2 NC X 1-1/4	-
30	900-01225	BOLT, 1/2 NC X 1-1/2	-
31	900-01753	CARRIAGE BOLT, 1/2 NC X 2	-
32	900-01349	BOLT, 5/8 NC X 2-1/2	-
33	900-06013	NUT, 5/8 NC	-
34	900-06143	NUT, SPIRALOCK, 1/2 NC	-
35	900-06009	NUT, 1/2 NC	-
36	900-11088	WASHER, 5/8 (SAE)	-
37	900-11035	WASHER, 1/2	-

FLAIL TUBE COMPONENTS (630, 822)

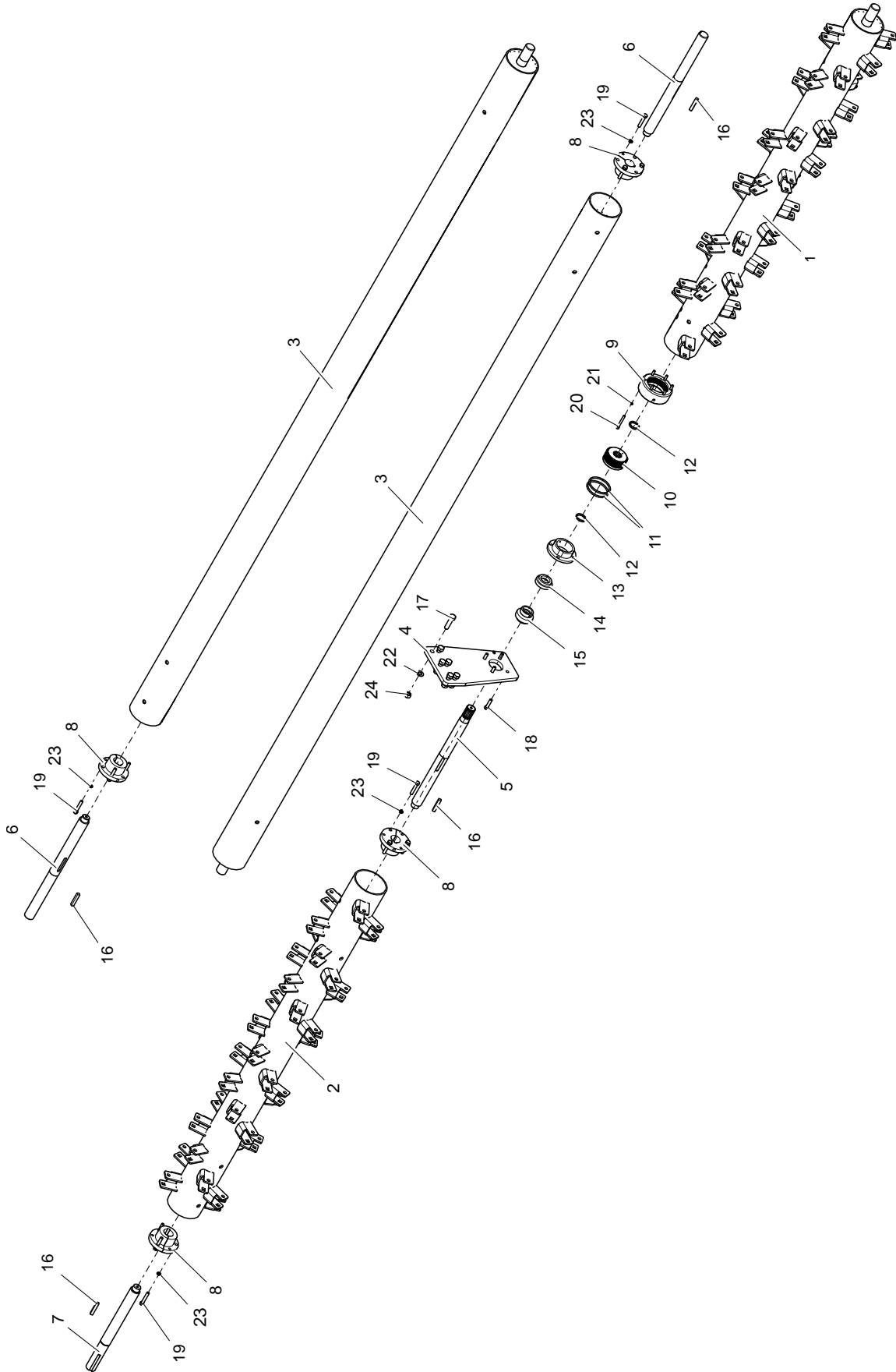

FLAIL TUBE COMPONENTS (630, 822)

ITEM NO.	PART NUMBER	DESCRIPTION	QTY.
1	500-2-0776	FLAIL TUBE, DRIVEN (630-822)	1
2	500-2-0775	FLAIL TUBE, DRIVE (630-822)	1
3	500-2-0383	SMOOTH FLAIL TUBE (630-822)	2
4	500-3-1190	CENTER BEARING PLATE	1
5	500-3-0785	CENTER SHAFT	1
6	500-3-0863	LONG SHAFT	2
7	500-3-0865	SHORT SHAFT	1
8	500-3-1060	HUB, 2" W/ KEYWAY	4
9	500-3-0345	OUTER DRIVE SLEEVE	1
10	500-3-0338	INNER DRIVE HUB	1
11	901-09126	O-RING	2
12	900-39030	SNAP RING	2
13	901-01300	BEARING, 4-BOLT ROUND	1
14	901-01281	BEARING PROTECTOR	1
15	901-01280	BEARING, INSERT 1-15/16	1
16	100-3-3331	KEY, 1/2 x 1/2 x 3	4
17	900-01409	BOLT, 3/4 NC x 2-3/4	-
18	900-01229	BOLT, 1/2 NC x 2	-
19	900-02526	BOLT, 1/2 NC x 2-3/4	-
20	900-03119	BOLT, 3/8 NC x 3	-
21	500-3-0779	WASHER, LOCK 3/8 (HIGH COLLAR)	-
22	900-11038	WASHER, FLAT 3/4	-
23	900-11013	WASHER, LOCK 1/2	-
24	900-06510	NUT, TOP LOCK 3/4 NC	-

FLAIL TUBE COMPONENTS (830, 1222)

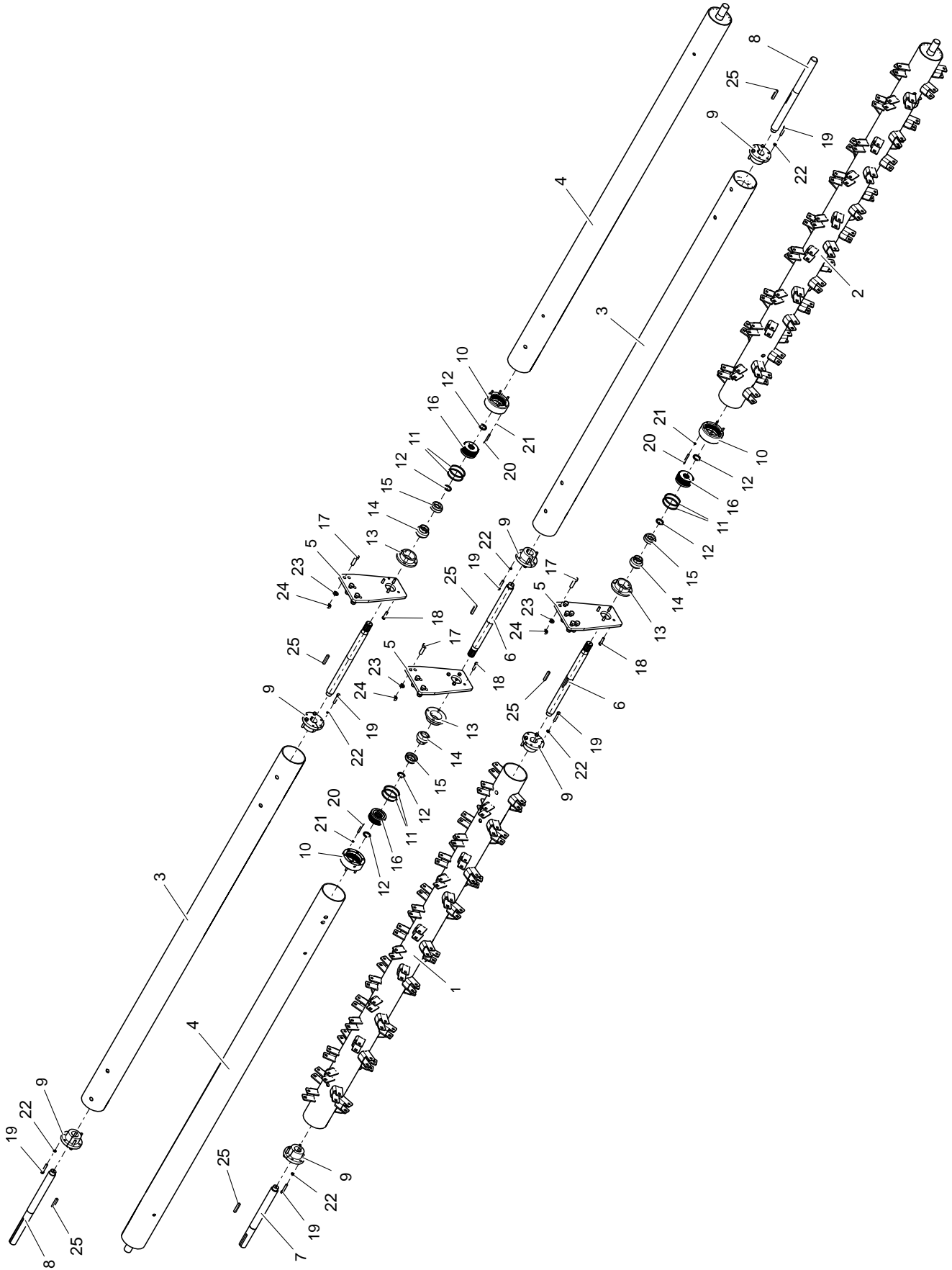

FLAIL TUBE COMPONENTS (830, 1222)

ITEM NO.	PART NUMBER	DESCRIPTION	QTY.
1	500-2-0779	FLAIL TUBE, DRIVE (1222)	1
	500-2-1182	FLAIL TUBE, DRIVE (830)	
2	500-2-0780	FLAIL TUBE, DRIVEN (1222)	1
	500-2-1181	FLAIL TUBE, DRIVEN (830)	
3	500-2-0556	SMOOTH FLAIL TUBE, DRIVE (1222)	2
	500-2-1186	SMOOTH FLAIL TUBE, DRIVE (830)	
4	500-2-0555	SMOOTH FLAIL TUBE, DRIVEN (1222)	2
	500-2-1185	SMOOTH FLAIL TUBE, DRIVEN (830)	
5	500-3-1190	CENTER BEARING PLATE	3
6	500-3-0785	CENTER SHAFT	3
7	500-3-0865	SHORT SHAFT	1
8	500-3-0863	LONG SHAFT	2
9	500-3-1060	HUB, 2" W/ KEYWAY	6
10	500-3-0345	OUTER DRIVE SLEEVE	3
11	901-09126	O-RING	6
12	900-39030	SNAP RING	6
13	901-01300	BEARING, 4-BOLT ROUND	3
14	901-01280	BEARING, INSERT 1-15/16	3
15	901-01281	BEARING PROTECTOR	3
16	500-3-0338	INNER DRIVE HUB	3
17	900-01409	BOLT, 3/4 NC x 2-3/4	-
18	900-01229	BOLT, 1/2 NC x 2	-
19	900-02526	BOLT, 1/2 NC x 2-3/4	-
20	900-03119	BOLT, 3/8 NC x 3	-
21	500-3-0779	WASHER, LOCK 3/8 (HIGH COLLAR)	-
22	900-11013	WASHER, LOCK 1/2	-
23	900-11038	WASHER, FLAT 3/4	-
24	900-06510	NUT, TOP LOCK 3/4 NC	-
25	100-3-3331	KEY, 1/2 x 1/2 x 3	6

BELT COVER COMPONENTS

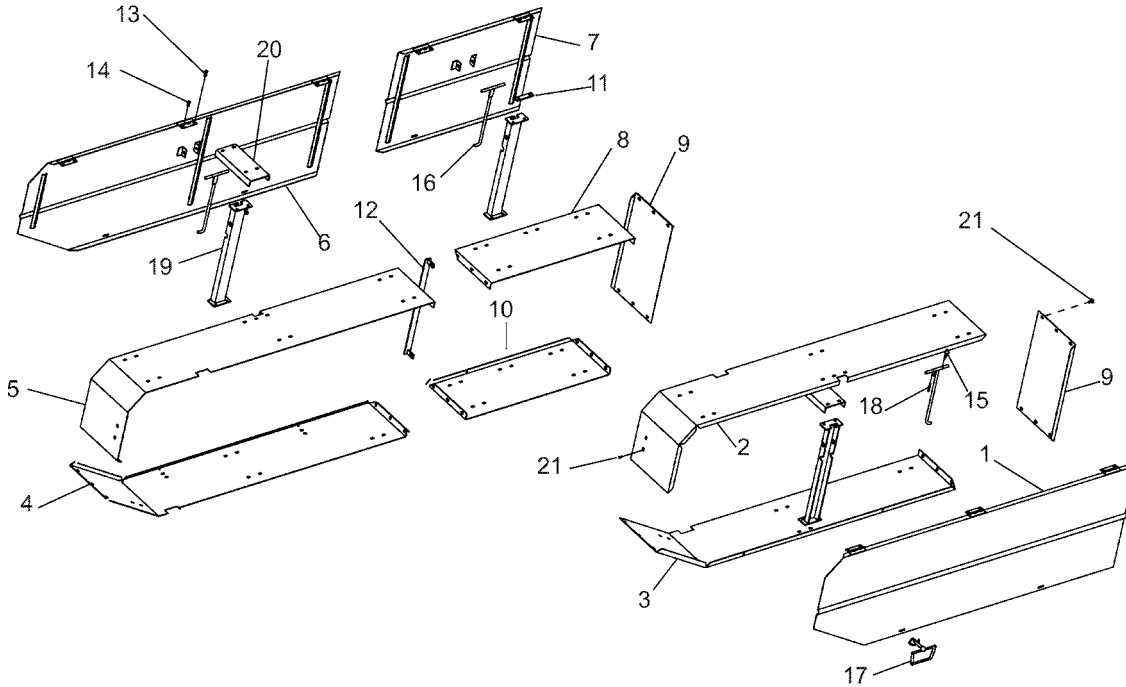

ITEM NO.	PART NUMBER	DESCRIPTION	QTY.
1	500-2-0581	FRONT DOOR WELD (LH)	1
2	500-3-1256	TOP SIDE SHIELD (LH)	1
3	500-3-1258	BOTTOM SIDE SHIELD (LH)	1
4	500-3-1259	BOTTOM SIDE SHIELD (RH)	1
	500-3-1738	BOTTOM SIDE SHIELD EXT RH (1222)	1
5	500-3-1257	TOP SIDE SHIELD (RH)	1
	500-3-1737	TOP SIDE SHIELD EXT RH (1222)	1
6	500-2-0582	FRONT DOOR WELD (RH)	1
7	500-2-0583	REAR DOOR WELD	1
8	500-3-1284	REAR TOP SHIELD (RH)	1
	500-3-1739	REAR TOP SIDE SHIELD RH EXT (1222)	1
9	500-3-1260	BACK SIDE SHIELD (LH)	2
	500-3-1740	REAR BOTTOM SIDE SHIELD RH EXT (1222)	1
10	500-3-1261	REAR BOTTOM SIDE SHIELD	1
	500-3-1741	BACK SIDE SHIELD EXT (1222)	1
11	500-3-1277	SPACER SUPPORT CHANNEL	1
12	500-2-0587	DOOR SUPPORT	1
13	900-01109	3/8 X 1 HEX BOLT	-
14	900-01105	3/8 X 3/4 HEX BOLT	-
15	900-25004	1/8" HAIR PIN	3
16	500-2-0585	PROP ROD WELD	3
17	905-04032	SPRING LATCH	2
18	900-29126	3/16X3/4 ROLL PIN	3
19	500-2-0584	SUPPORT WELDMENT, SIDE COVER	3
20	500-3-1269	TOP SUPPORT CHANNEL	2
	500-3-1742	TOP SUPPORT CHANNEL EXT (1222)	1
21	900-01694	3/8 X 3/4 CARRIAGE BOLT	-
-	500-3-0407	BRACKET, RUBBER LATCH	-
-	905-04019	RUBBER LATCH	-
-	905-04025	HOOD BRACKET	-

FLAIL COMPONENTS

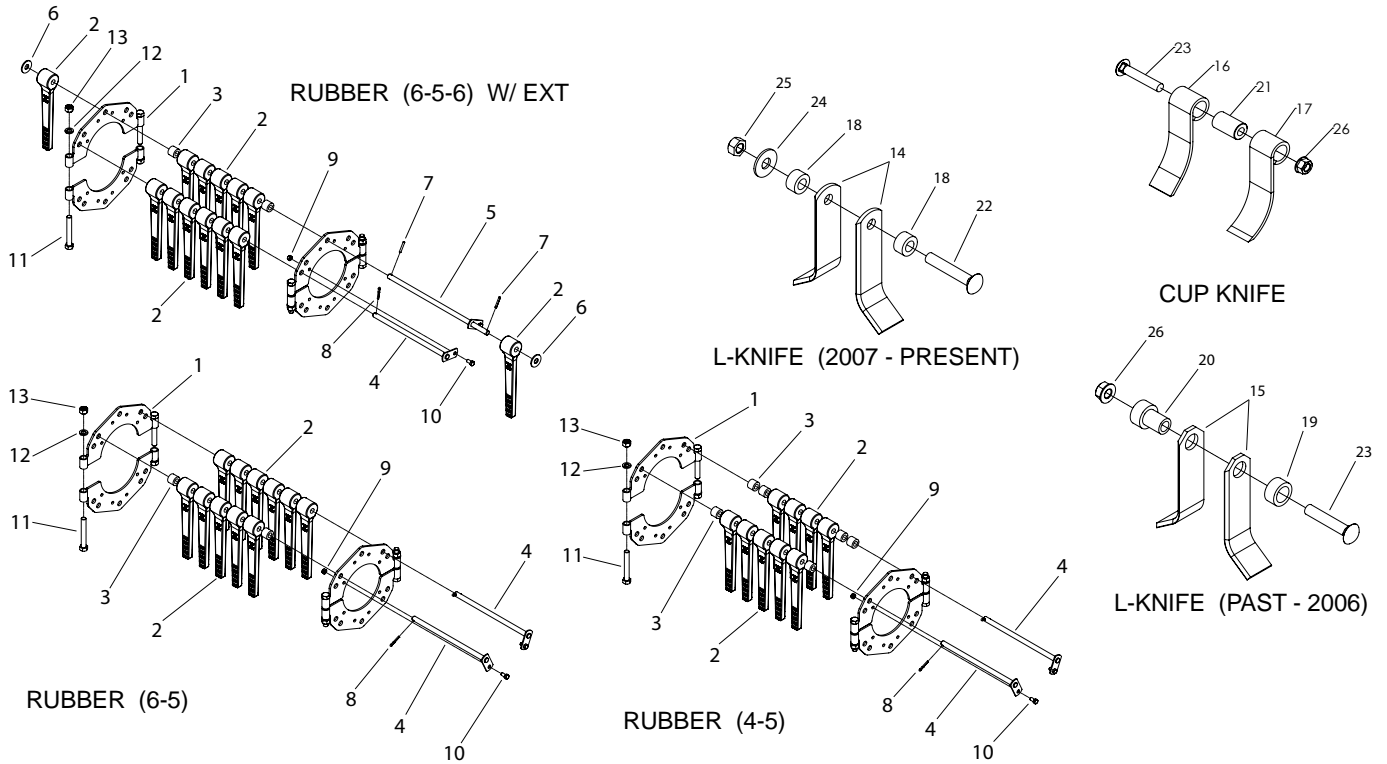

ITEM NO.	PART NUMBER	DESCRIPTION	QTY.
1	500-2-0067	FAIL MTG BRACKET WELD HALF	-
2	500-3-2578	RUBBER FLAIL (NAUFSINGER) (2012 - PRESENT)	-
	500-3-0316	RUBBER FLAIL (PAST - 2012)	-
3	500-3-0151	SPACER, 1", RUBBER FLAIL	-
4	500-2-0068	PIN WELD, RUBBER FLAIL	-
5	500-2-0069	PIN WELD, EXTENTION, RUBBER FLAIL	-
6	900-11131	WASHER, NYLON 5/8	-
7	900-29153	PIN, ROLL 7/32 X 1-1/2	-
8	900-23041	PIN, COTTER 3/16 X 1	-
9	900-06500	NUT, LOCK 3/8 NC	-
10	900-01105	BOLT, HEX HEAD 3/8 NC X 3/4, GR5 ZP	-
11	900-01363	BOLT, HEX HEAD 5/8 NC X 4-1/2, GR5 ZP	-
12	900-11015	WASHER, LOCK 5/8	-
13	900-06013	NUT, HEX HEAD 5/8 NC	-
14	505-3-0001	L-KNIFE (SMALL HOLE)	-
15	500-3-1735	L-KNIFE (LARGE HOLE)	-
16	505-3-0004	STEEL CUP KNIFE, SHORT 7" (2008 - PRESENT)	-
17	505-3-0972	STEEL CUP KNIFE, SHORT 6-3/16" (PAST - 2007)	-
18	500-3-2134	SPACER, SMALL HOLE	-
19	500-3-1736	SPACER, LARGE HOLE	-
20	500-3-1733	BUSHING	-
21	505-3-0405	BUSHING, WEAR	-
22	900-03064	BOLT, CARRIAGE 5/8 NC X 3-3/4, GR8 ZP (PARTIAL THREAD)	-
23	900-01792	BOLT, CARRIAGE 5/8 NC X 3-1/2, GR5 ZP (PARTIAL THREAD)	-
24	900-11037	WASHER, FLAT 5/8	-
25	900-06508	NUT, TOP LOCK 5/8 NC, GR8	-
26	900-06145	NUT, SPIRALOCK FLANGE 5/8 NC, GR8	-

TOP COVER COMPONENTS

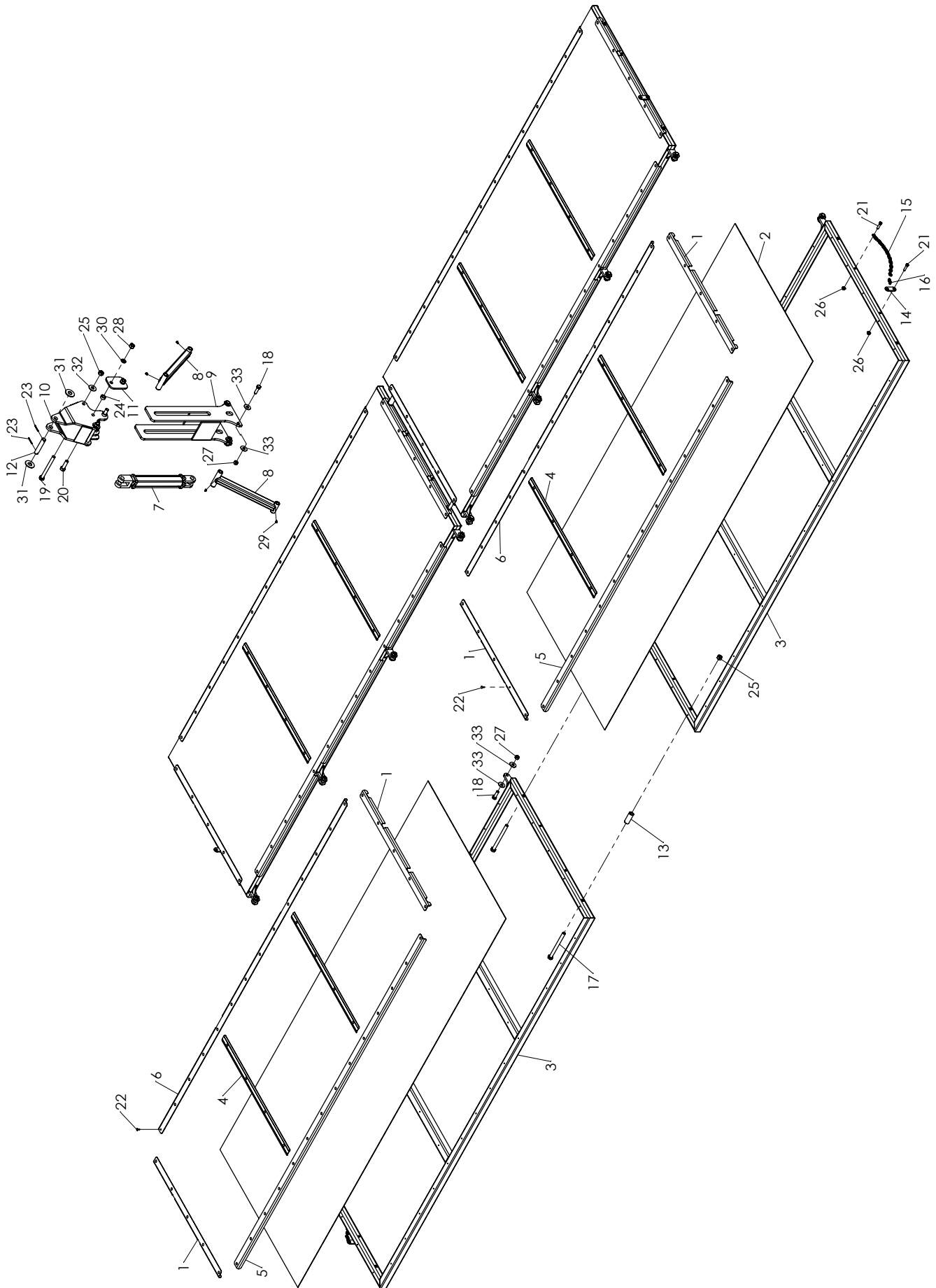

TOP COVER COMPONENTS

ITEM NO.	PART NUMBER	DESCRIPTION	QTY.
1	500-3-2980	INSIDE/OUTSIDE TIE DOWN	8
2	500-3-2859	TOP RUBBER COVER - 1222	4
	500-3-2912	TOP RUBBER COVER - 830	`
	500-3-2899	TOP RUBBER COVER - 630/822	
3	500-2-1454	TOP COVER FRAME - 1222	4
	500-2-1411	TOP COVER FRAME - 830	
	500-2-2793	TOP COVER FRAME - 630/822	
4	500-3-3057	CENTER STRAP - TOP COVER	8
5	500-3-2978	FRONT TIE DOWN ANGLE - 1222	4
	500-3-3016	FRONT TIE DOWN ANGLE - 830	
	500-3-2900	FRONT TIE DOWN ANGLE - 630/822	
6	500-3-2979	REAR TIE DOWN ANGLE - 1222	4
	500-3-3017	REAR TIE DOWN ANGLE - 830	
	500-3-3008	REAR TIE DOWN ANGLE - 630/822	
7	905-21453	CYLINDER, 2" X 12"	1
8	500-2-1321	LIFT ARM	2
9	500-2-1323	CYLINDER SUPPORT ARM	1
10	500-2-1322	PUSH BRACKET	1
11	500-3-2698	HOLD DOWN PLATE	2
12	500-3-2699	UPPER CYLINDER PIN	1
13	500-3-2723	OUTER SPACE TUBE	2
14	500-3-2860	CHAIN MOUNT	4
15	500-3-2881	COVER LOCK CHAIN	2
16	900-42067	1/4" QUICK LINK	2
17	900-01437	BOLT, 3/4 NC X 8-1/2	-
18	900-01345	BOLT, 5/8 NC X 2	-
19	900-01433	BOLT, 3/4 NC X 7-1/2	-
20	900-01407	BOLT, 3/4 NC X 2-1/2	-
21	900-01175	BOLT, 7/16 NC X 1-1/2	-
22	900-21480	RIVIT 3/16" (0.675)	-
23	900-29138	ROLL PIN, 3/16 X 2	2
24	500-3-2696	SPACER, SLIDE	4
25	900-06510	NUT, TOP LOCK, 3/4 NC	-
26	900-06141	NUT, SPIRALOCK, 7/16 NC	-
27	900-06508	NUT, TOP LOCK, 5/8 NC	-
28	900-06015	NUT, 3/4 NC	-
29	905-15024	GREASE ZERK, 1/4-28 UNF STRAIGHT	4
30	900-11017	WASHER, LOCK 3/4	-
31	900-11040	WASHER, 1	-
32	900-11038	WASHER, 3/4	-
33	900-11037	WASHER, 5/8	-

REAR STRUT - DUAL SMALL TIRE COMPONENTS

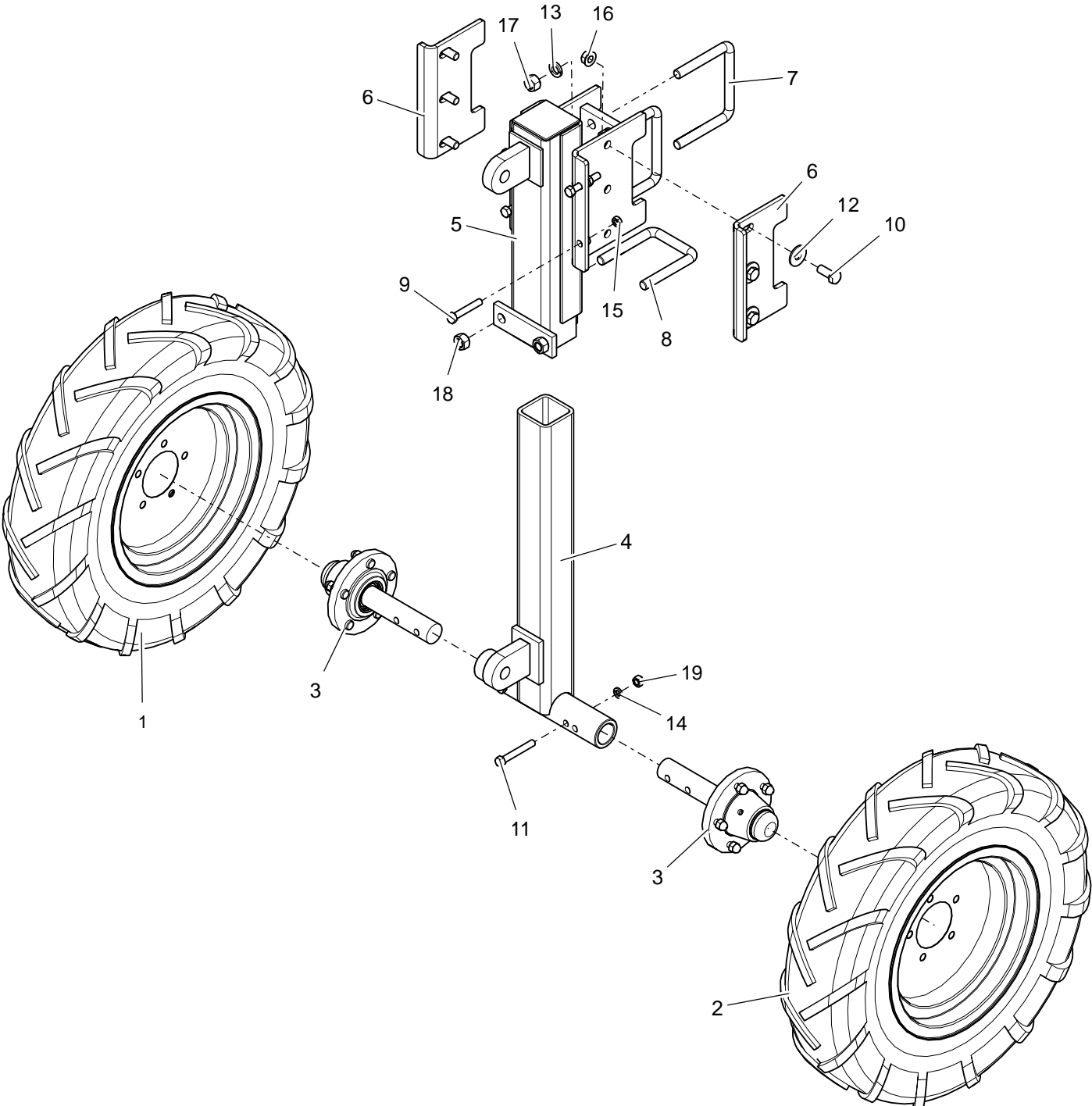

REAR STRUT - DUAL SMALL TIRE COMPONENTS

ITEM NO.	PART NUMBER	DESCRIPTION	QTY.
1	500-2-0157	TRACTION TIRE ASSY (RH)	1
	905-09100	- TIRE, 7.6 x 15	
	905-09078	- RIM, 15 x 6 x 5 BOLT	
2	500-2-0158	TRACTION TIRE ASSY (LH)	1
	905-09100	- TIRE, 7.6 x 15	
	905-09078	- RIM, 15 x 6 x 5 BOLT	
3	500-2-0972	HUB & SPINDLE ASSY	2
4	500-2-0973	LOWER STRUT (22")	1
	500-2-0595	LOWER STRUT (30")	
5	500-2-0576	UPPER STUT	1
6	500-3-2421	TOE PLATE	2
7	200-3-0024	U-BOLT, 3/4 NC x 6 x 5.5	2
8	200-3-1440	U-BOLT, 3/4 NC x 4 x 5.5	1
9	900-03454	BOLT, 1/2 NC x 3	-
10	900-01341	BOLT, 5/8 NC x 1-1/2	-
11	900-01241	BOLT, 1/2 NC x 3-1/2	-
12	900-11037	WASHER, 5/8	-
13	900-11017	WASHER, LOCK, 3/4	-
14	900-11013	WASHER, LOCK, 1/2	-
15	900-06276	NUT, JAM, 1/2 NC	-
16	900-06145	NUT, SPIRALOCK, 5/8 NC	-
17	900-06015	NUT, 3/4 NC	-
18	900-06510	NUT, TOP LOCK, 3/4 NC	-
19	900-06009	NUT, 1/2 NC	-

REAR STRUT - SINGLE LARGE TIRE COMPONENTS

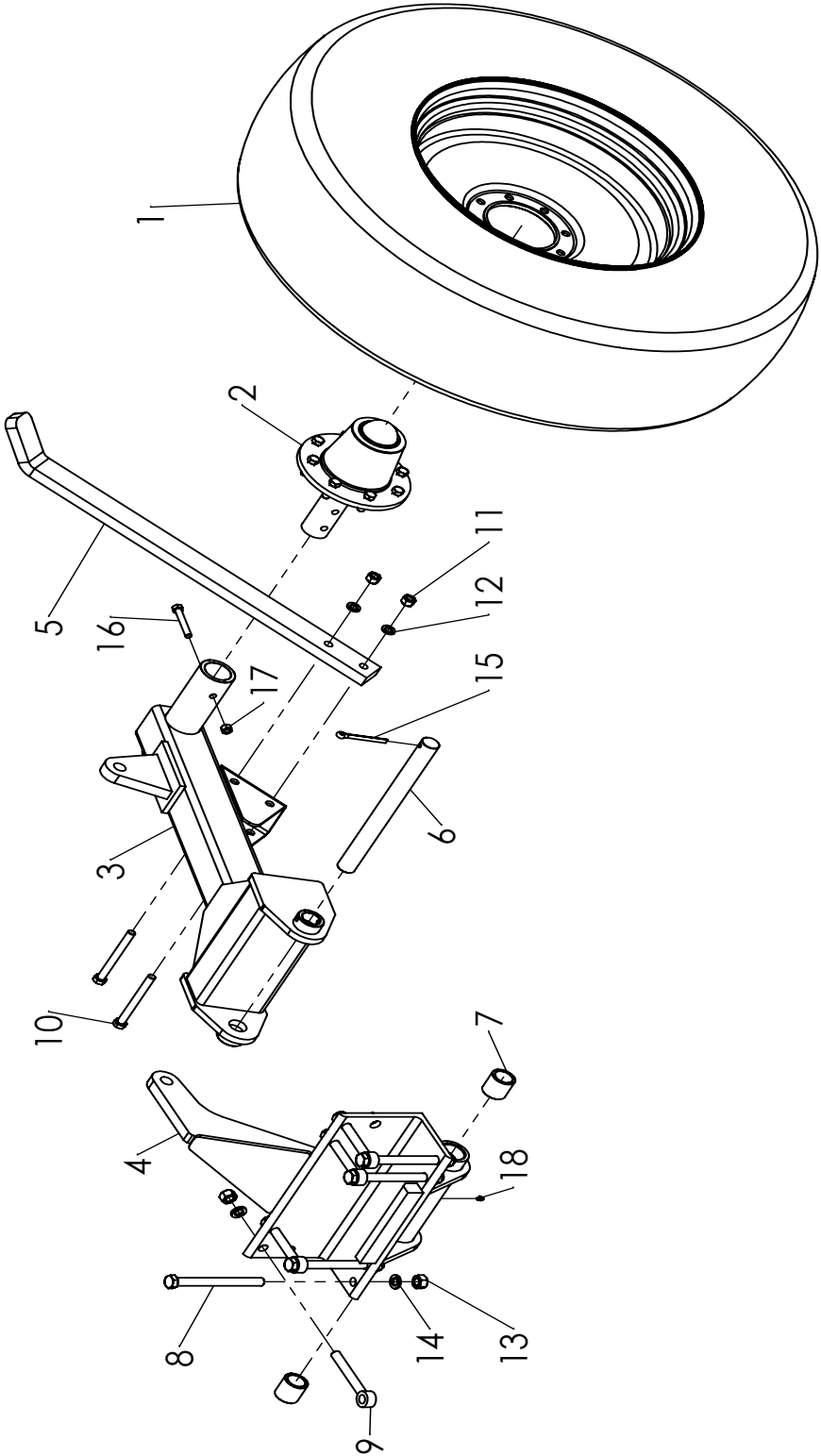

REAR STRUT - SINGLE LARGE TIRE COMPONENTS

ITEM NO.	PART NUMBER	DESCRIPTION	QTY.
1	700-2-0168	TRACTION TIRE ASSY (RH)	1
	905-09130	- TIRE, 12.4 X 24	
	905-09127	- RIM, 24 x 10 x 8 BOLT	
	700-2-0167	TRACTION TIRE ASSY (LH)	
	905-09130	- TIRE, 12.4 X 24	
	905-09127	- RIM, 24 x 10 x 8 BOLT	
2	700-2-0165	HUB & SPINDLE ASSY	1
3	500-2-0993	SINGLE REAR STRUT (RH)	1
	500-2-1065	SINGLE REAR STRUT (LH)	
4	500-2-1495	MOUNTING ANGLE - EXTENDED	1
5	500-3-2259	WHEEL SCRAPER (12.4 x 24 TIRE)	1
6	500-3-1328	PIVOT PIN	1
7	500-3-1151	BUSHING	2
8	900-01437	BOLT, 3/4 NC x 8-1/2	4
9	900-03463	EYE BOLT, 3/4 NC x 6	4
10	900-01369	BOLT, 5/8 NC X 6	2
11	900-06013	NUT, 5/8 NC	2
12	900-11015	WASHER, LOCK, 5/8	2
13	900-06015	NUT, 3/4 NC	8
14	900-11017	WASHER, LOCK, 3/4	8
15	900-23084	PIN, COTTER, 3/8 X 3-1/2	1
16	900-01241	BOLT, 1/2 NC x 3-1/2	1
17	900-06504	NUT, TOP LOCK, 1/2 NC	1
18	905-15024	GREASE ZERK, 1/4-28 UNF STRAIGHT	1

REAR STRUT - DUAL LARGE TIRE COMPONENTS

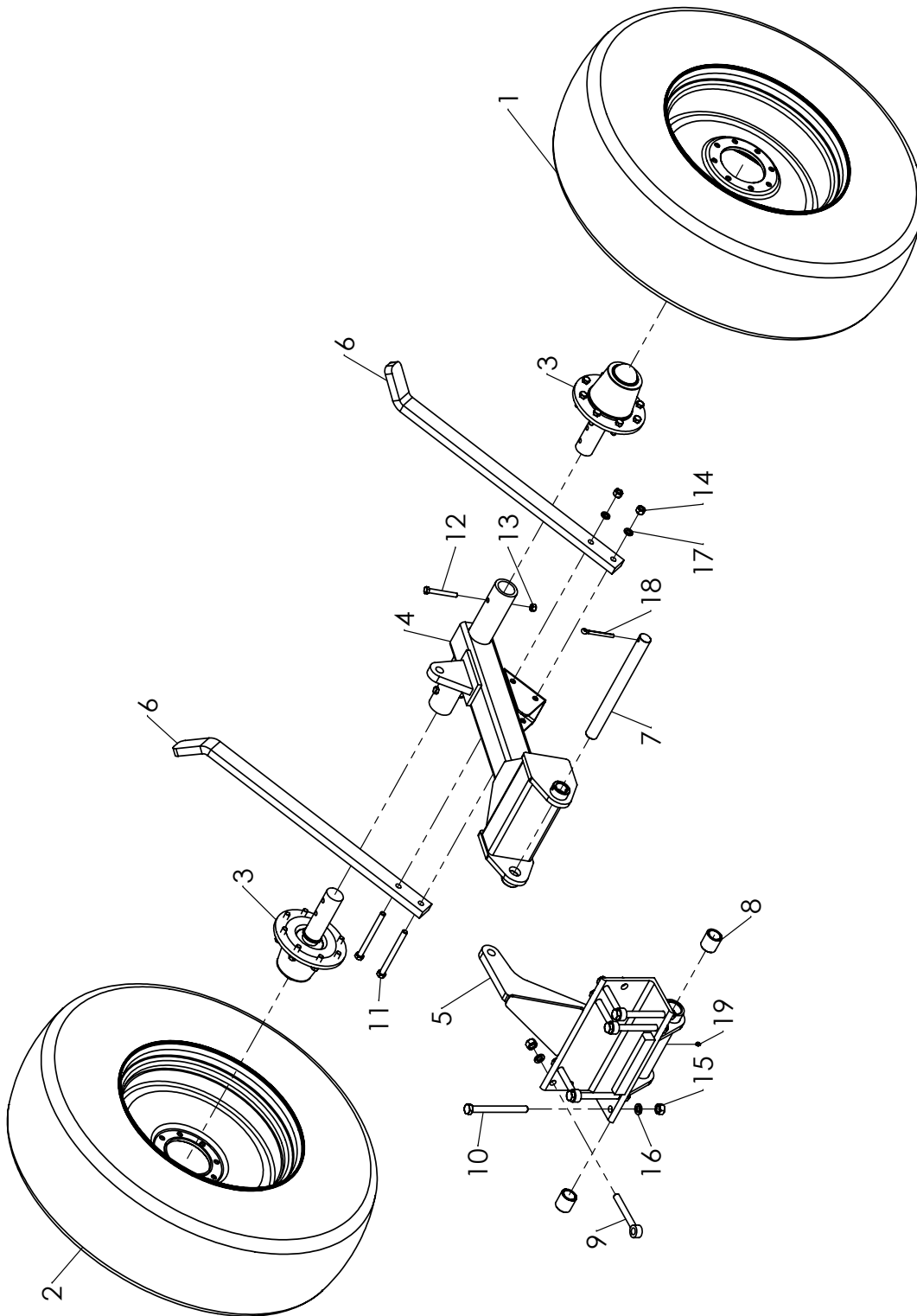

REAR STRUT - DUAL LARGE TIRE COMPONENTS

ITEM NO.	PART NUMBER	DESCRIPTION	QTY.
1	700-2-0167	TRACTION TIRE ASSY (RH)	1
	905-09130	- TIRE, 12.4 X 24	
	905-09127	- RIM, 24 x 10 x 8 BOLT	
2	700-2-0168	TRACTION TIRE ASSY (LH)	1
	905-09130	- TIRE, 12.4 X 24	
	905-09127	- RIM, 24 x 10 x 8 BOLT	
3	700-2-0165	HUB & SPINDLE ASSY	2
4	500-2-0998	DUAL REAR STRUT (22")	1
	500-2-1023	DUAL REAR STRUT (30")	
5	500-2-1495	MOUNTING ANGLE - EXTENDED	1
6	500-3-2259	WHEEL SCRAPER (12.4 x 24 TIRE)	2
7	500-3-1328	PIVOT PIN	1
8	500-3-1151	BUSHING	2
9	900-03463	EYE BOLT, 3/4 NC x 6	4
10	900-01437	BOLT, 3/4 NC x 8-1/2	4
11	900-01373	BOLT, 5/8 NC x 7	2
12	900-01245	BOLT, 1/2 NC x 4	2
13	900-06504	NUT, TOP LOCK, 1/2 NC	2
14	900-06013	NUT, 5/8 NC	2
15	900-06015	NUT, 3/4 NC	8
16	900-11017	WASHER, LOCK, 3/4	8
17	900-11015	WASHER, LOCK, 5/8	2
18	900-23084	PIN, COTTER, 3/8 X 3-1/2	1
19	905-15024	GREASE ZERK, 1/4-28 UNF STRAIGHT	1

REAR STRUT - DUAL LARGE TIRE (PIVOT) COMPONENTS

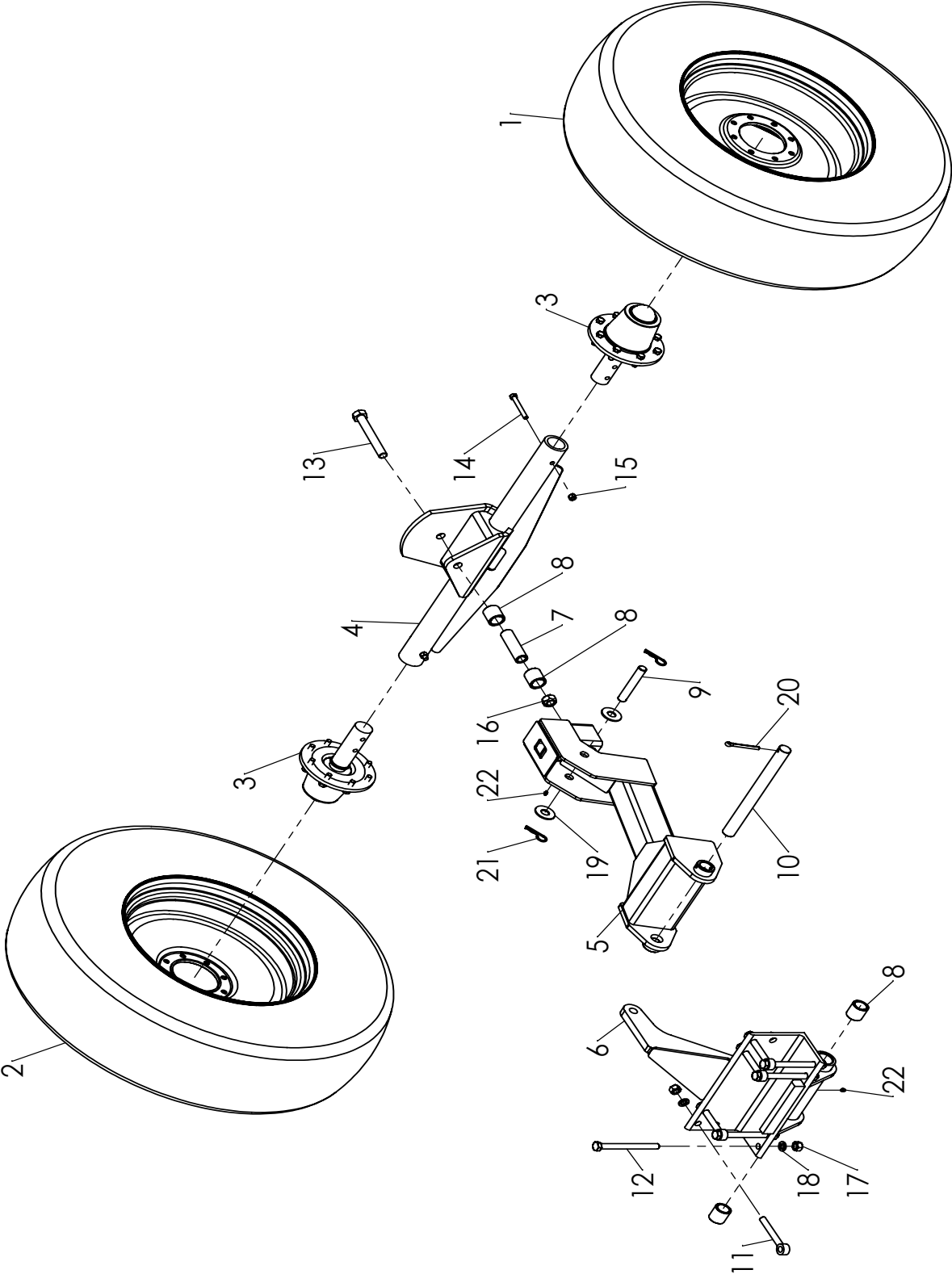

REAR STRUT - DUAL LARGE TIRE (PIVOT) COMPONENTS

ITEM NO.	PART NUMBER	DESCRIPTION	QTY.
1	700-2-0167	TRACTION TIRE ASSY (RH)	1
	905-09130	- TIRE, 12.4 X 24	
	905-09127	- RIM, 24 x 10 x 8 BOLT	
2	700-2-0168	TRACTION TIRE ASSY (LH)	1
	905-09130	- TIRE, 12.4 X 24	
	905-09127	- RIM, 24 x 10 x 8 BOLT	
3	700-2-0165	HUB & SPINDLE ASSY	2
4	500-2-1072	SPINDLE HOLDER (44")	1
	500-2-1239	SPINDLE HOLDER (30")	
5	500-2-1071	REAR DUAL PIVOT STRUT	1
6	500-2-1495	MOUNTING ANGLE - EXTENDED	1
7	500-3-2236	PIVOT BUSHING	1
8	500-3-1151	BUSHING	4
9	500-3-2270	CYLINDER PIN	1
10	500-3-1328	PIVOT PIN	1
11	900-03463	EYE BOLT, 3/4 NC x 6	4
12	900-01437	BOLT, 3/4 NC x 8-1/2	4
13	900-01541	BOLT, 1 NC x 7-1/2	1
14	900-01245	BOLT, 1/2 NC x 4	2
15	900-06504	NUT, TOP LOCK, 1/2 NC	2
16	900-06514	NUT, TOP LOCK, 1 NC	1
17	900-06015	NUT, 3/4 NC	8
18	900-11017	WASHER, LOCK, 3/4	8
19	900-11040	WASHER, 1	2
20	900-23084	PIN, COTTER, 3/8 X 3-1/2	1
21	900-25007	HITCH PIN, 3/16	2
22	905-15024	GREASE ZERK, 1/4-28 UNF STRAIGHT	2

REAR STEER - DUAL LARGE TIRE (PIVOT) COMPONENTS

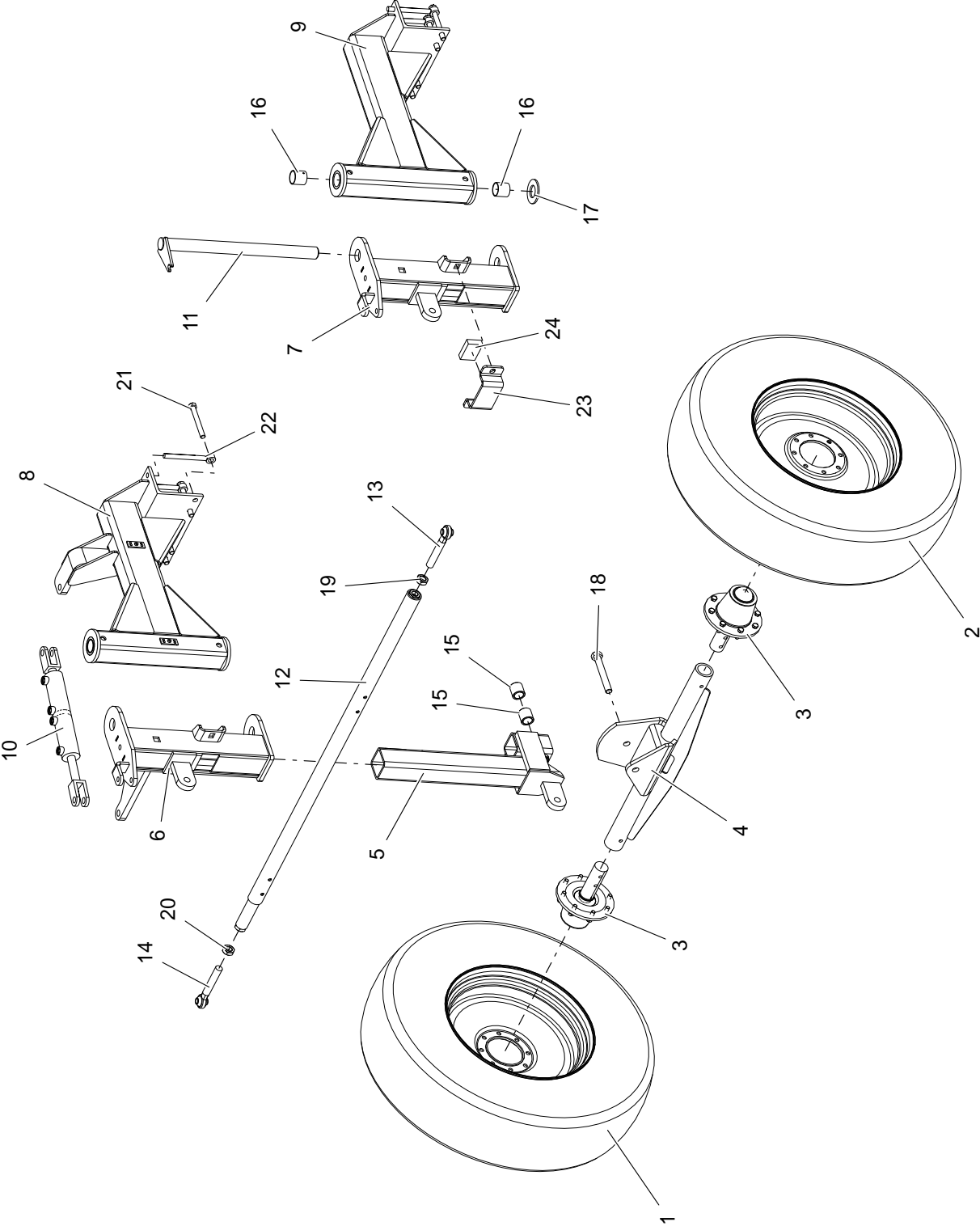

REAR STEER - DUAL LARGE TIRE (PIVOT) COMPONENTS

ITEM NO.	PART NUMBER	DESCRIPTION	QTY.
1	700-2-0167	TRACTION TIRE ASSY (RH)	2
	905-09130	- TIRE, 12.4 X 24	
	905-09127	- RIM, 24 x 10 x 8 BOLT	
2	700-2-0168	TRACTION TIRE ASSY (LH)	2
	905-09130	- TIRE, 12.4 X 24	
	905-09127	- RIM, 24 x 10 x 8 BOLT	
3	700-2-0165	HUB & SPINDLE ASSY	4
4	500-2-1042	SPINDLE HOLDER (30")	2
	500-2-1151	SPINDLE HOLDER (44")	
5	500-2-1153	LOWER STRUT	2
6	500-2-2448	LOWER PIVOT (W/ EAR)	1
7	500-2-1220	LOWER PIVOT (W/O EAR)	1
8	500-2-1209	UPPER STRUT (W/ EAR)	1
9	500-2-1219	UPPER STRUT (W/O EAR)	1
10	905-21452	CYLINDER 1-1/4 x 2-1/2 x 4	1
11	500-2-0828	PIN	2
12	500-2-1200	TIE ROD (66" SPACING)	1
	500-2-1205	TIE ROD (88" - 154" SPACING)	
13	903-05031	PIVOT LINK (RH)	1
14	903-05030	PIVOT LINK (LH)	1
15	500-3-1151	BUSHING	4
16	200-3-4081	BUSHING	4
17	901-01145	BUSHING (OILITE)	2
18	900-01541	BOLT, 1 NC x 7-1/2	2
19	900-06288	JAM NUT, 1-1/8 NC (RH)	1
20	900-06310	JAM NUT, 1-1/8 NC (LH)	1
21	900-01429	BOLT, 3/4 NC x 6-1/2	8
22	900-03462	EYE BOLT, 3/4 NC x 8	8
23	500-3-2517	PRESSURE PLATE	2
24	500-3-2519	WEAR	2

REAR STEER - DUAL SMALL TIRE COMPONENTS

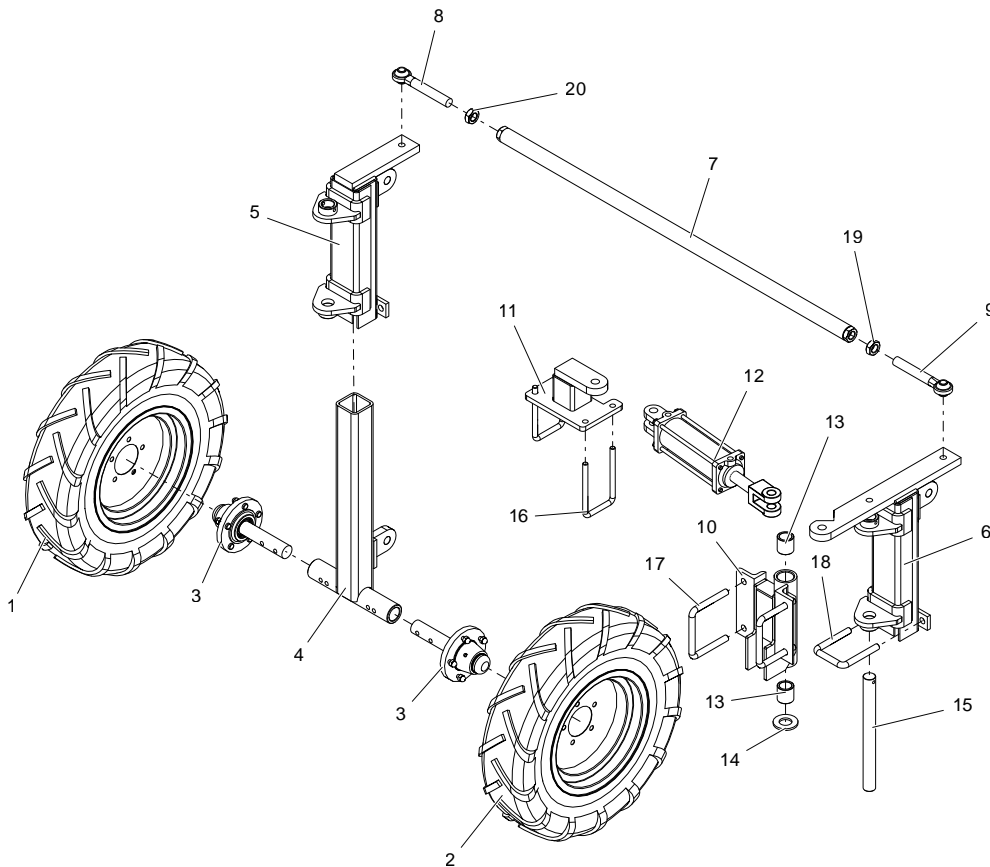

ITEM NO.	PART NUMBER	DESCRIPTION	QTY.
1	500-2-0158	TRACTION TIRE ASSY (LH)	-
	905-09100	- TIRE, 7.6 x 15	
	905-09078	- RIM, 15 x 6 x 5 BOLT	
2	500-2-0157	TRACTION TIRE ASSY (RH)	-
	905-09100	- TIRE, 7.6 x 15	
	905-09078	- RIM, 15 x 6 x 5 BOLT	
3	500-2-0972	HUB & SPINDLE ASSY	-
4	500-2-0973	LOWER STRUT (22")	-
	500-2-0596	LOWER STRUT (30")	
5	500-2-0625	UPPER STRUT (W/O EAR)	-
6	500-2-0624	UPPER STRUT (W/ EAR)	-
7	500-2-1200	TIE ROD (66" SPACING)	-
	500-2-1205	TIE ROD (88" - 154" SPACING)	
8	903-05030	PIVOT LINK (LH)	-
9	903-05031	PIVOT LINK (RH)	-
10	500-2-0622	PIVOT BASE	-
11	500-2-0621	CYLINDER MOUNT	1
12	905-21302	CYLINDER 3-1/2 x 8	1
13	500-3-1151	BUSHING	-
14	500-3-0538	SPACER BUSHING	-
15	500-3-1328	PIVOT PIN	-
16	200-3-0017	U-BOLT, 5/8 NC x 4 x 7-1/4	-
17	200-3-0024	U-BOLT, 3/4 NC x 6 x 5-1/2	-
18	200-3-1440	U-BOLT, 3/4 NC x 4 x 5-1/2	-
19	900-06288	JAM NUT, 1-1/8 NC (RH)	-
20	900-06310	JAM NUT, 1-1/8 NC (LH)	-

CIRCULAR KNIFE SCALPER - PARALLEL ARM

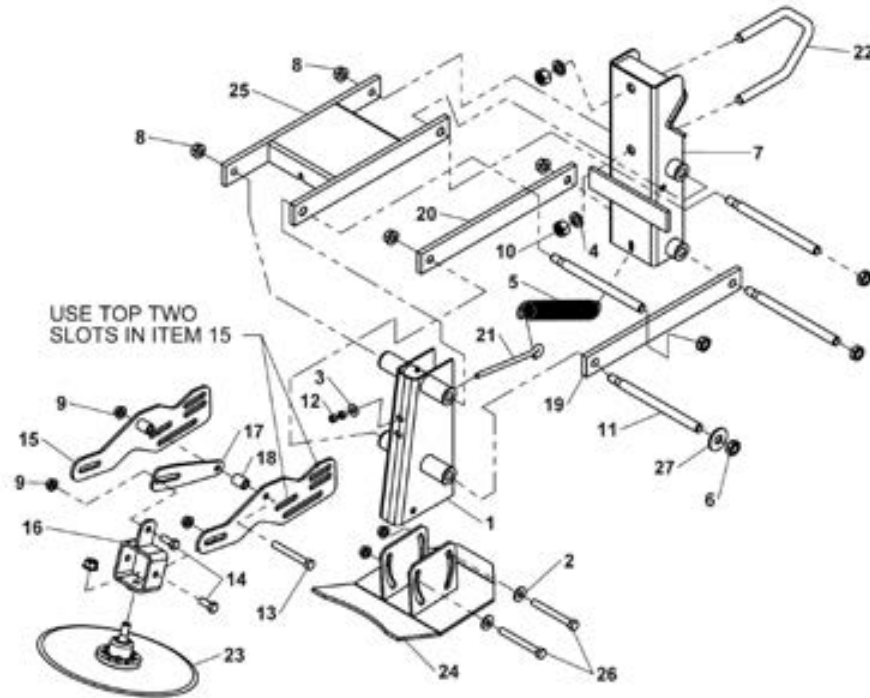

ITEM NO.	PART NUMBER	DESCRIPTION	QTY.
1	500-2-0338	UPRIGHT WELD	1
2	900-11035	1/2 FLAT WASHER, ZP	2
3	900-11033	3/8 FLAT WASHER, ZP	1
4	900-11017	3/4 LOCK WASHER	2
5	400-3-0263	SPRING, GM AND ALLOWBOOM	
6	900-06510	3/4 NC TOP LOCK NUT, ZP	4
7	500-2-0330	MOUNT WELD	1
8	900-06145	5/8 NC SPIRALOCK FLANGE NUT	5
9	900-06143	1/2 NC SPIRALOCK FLANGE NUT	6
10	900-06015	3/4 NC HEX NUT ZP	2
11	200-3-2631	PIN, PLATED	4
12	900-06005	3/8 NC HEX NUT, ZP	2
13	900-01245	1/2 NC X 4 HEX BOLT, GR5	1
14	900-01223	1/2 NC X 1-1/4 HEX BOLT	3
15	500-3-1563	PLATE, BRACKET, REAR TOP	2
16	500-2-0774	BRACKET, PIVOT	1
17	500-3-1557	STRAP, TOP REAR, ADJ.	1
18	500-3-1556	REAR SPACER TUBE	2
19	500-3-0992	BAR, 3/4 HOLES	1
20	500-3-0991	BAR, 5/8 HOLES	1
21	500-3-0675	3/8 EYE BOLT X 8" LONG	1
22	500-3-0635	A-BOLT, 3/4 X 4 X 4	1
23	500-2-0762	HUB ASSY, SCALPER	1
	500-3-1582	DISC	1
	901-09219	HUB ASSY	1
	901-09220	HUB REPAIR KIT	1
24	500-2-0704	SCALPER SHOE WELD	1
25	500-2-0518	H-WELD	1
26	900-01247	1/2 NC X 4-1/2 HEX BOLT GR5	2

CIRCULAR KNIFE SCALPER - STRAIGHT ARM

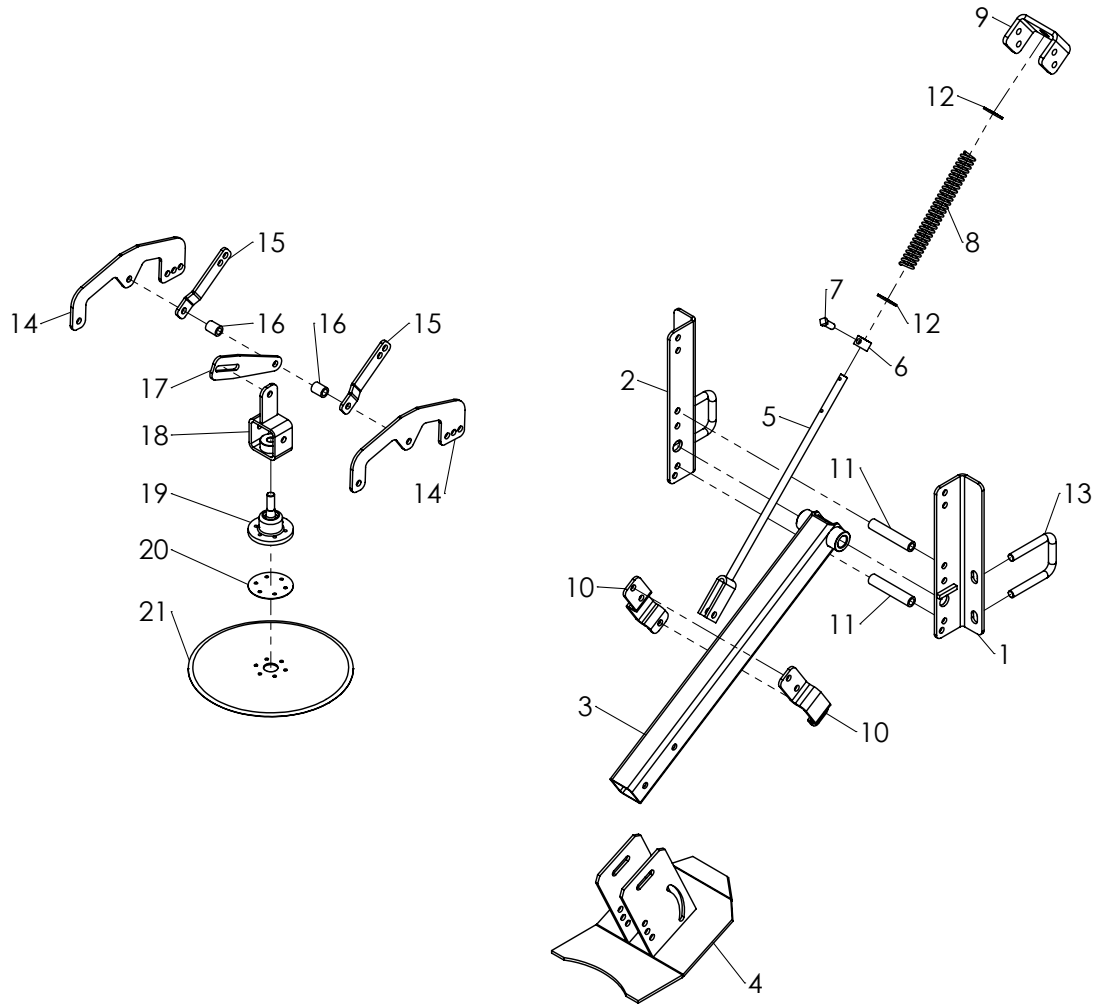

ITEM NO.	PART NUMBER	DESCRIPTION	QTY.
1	500-2-1438	MOUNT WELD (RH)	1
2	500-3-2948	MOUNT (LH)	1
3	500-2-1318	PIVOT TUBE WELD	1
4	500-2-1068	SCALPER SHOE	1
5	500-2-0072	LIFT ROD	1
6	500-3-0172	RETAINING COLLAR	1
7	900-16063	SET SCREW, 1/2 N x 1-1/4	1
8	500-3-0157	SPRING	1
9	500-3-1756	SPRING RETAINER	1
10	500-3-1757	LIFT ROD CLAMP	2
11	500-3-1561	MOUNT SPACER	2
12	900-11037	WASHER, 5/8	2
13	900-35026	U-BOLT, 5/8 NC x 3 x 4-1/2	2
14	500-3-2507	SHOE LINK BAR	2
15	500-3-2265	SHOE ADJUSTMENT ARM	2
16	500-3-1556	DISC SPACER	2
17	500-3-1557	DISC ADJUSTMENT ARM	1
18	500-2-1138	DISC MOUNT	1
19	905-09178	ROTARY DISC HUB	1
20	500-3-1940	DISC COVER	1
21	500-3-1582	ROTARY DISC	1

STRAIGHT KNIFE SCALPER - PARALLEL ARM

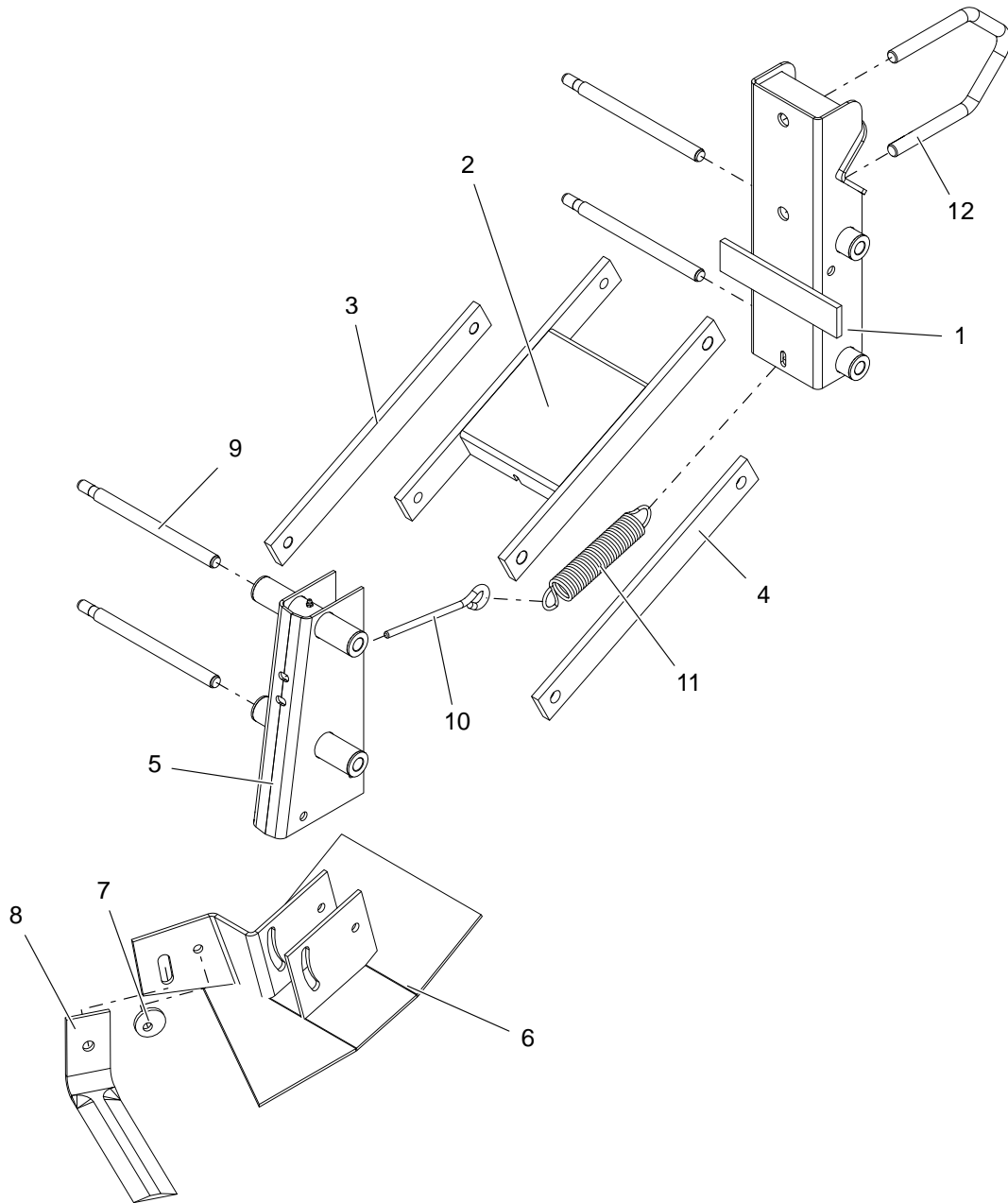

ITEM NO.	PART NUMBER	DESCRIPTION	QTY.
1	500-2-0330	UPPER MOUNT	1
2	500-2-0518	"H" LINKAGE ARM	1
3	500-3-0991	LINKAGE ARM (LH)	1
4	500-3-0992	LINKAGE ARM (RH)	1
5	500-2-0338	LOWER SHOE MOUNT	1
6	500-2-0335	SHOE (LH)	1
7	500-2-0336	SHOE (RH)	1
8	500-3-0201	ECCENTRIC SPACER	1
9	500-3-0910	KNIFE SCALPER	1
9	200-3-2631	PIN	4
10	500-3-0675	EYE BOLT, 3.8 x 8	1
11	400-3-0263	EXTENSION SPRING	1
12	500-3-0635	A-BOLT, 3/4 NC x 4 x 4	1

SCALPER TOOLBAR COMPONENTS - PARALLEL ARM

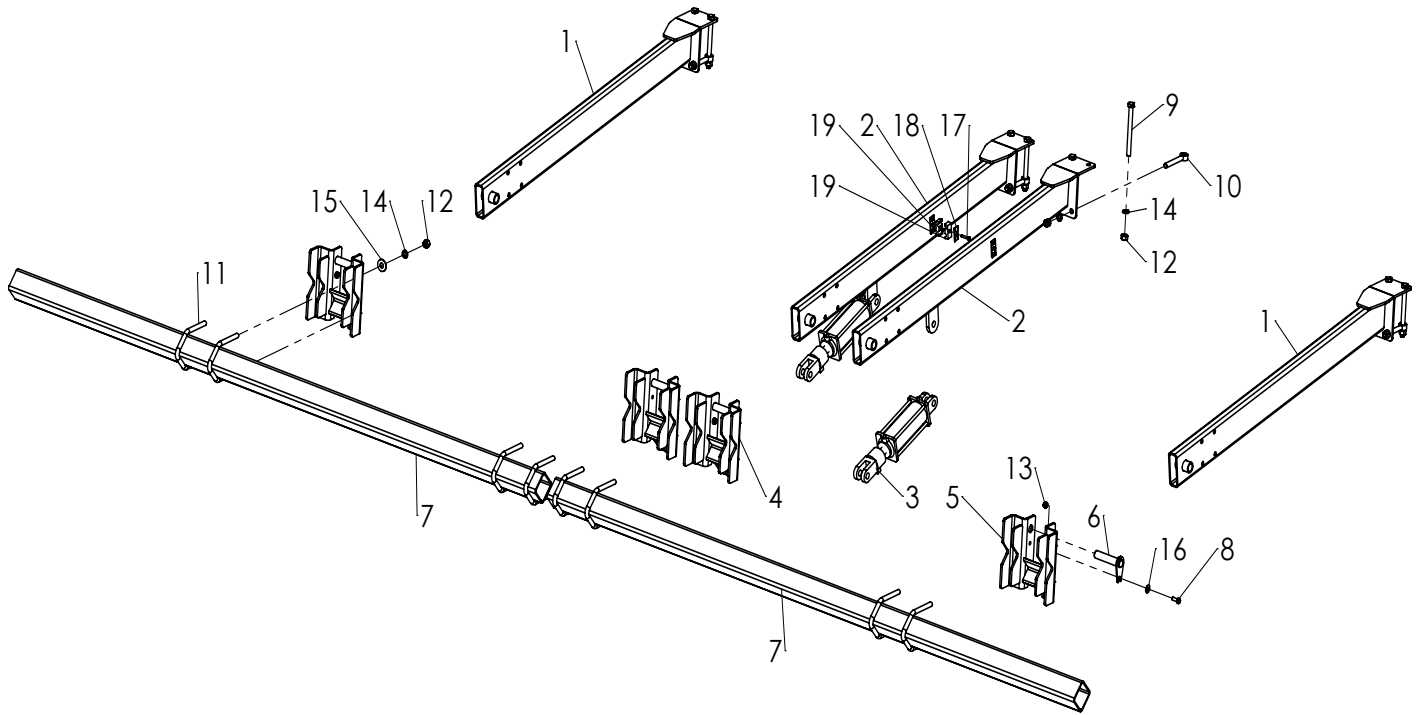

ITEM NO.	PART NUMBER	DESCRIPTION	QTY.
1	500-2-1437	OUTER SETBACK ARM WELDMENT (LARGE TIRES)	-
	500-2-1040	OUTER SETBACK ARM WELDMENT (SMALL TIRES)	-
2	500-2-1436	INNER SETBACK ARM WELDMENT (LARGE TIRES)	-
	500-2-1041	INNER SETBACK ARM WELDMENT (SMALL TIRES)	-
3	905-21400	HYDRAULIC CYLINDER - 3.5 X 8	-
	905-21380	- SEAL KIT (<i>PRINCE CYLINDERS ONLY</i>)	-
	905-21401	- SEAL KIT (<i>MONARCK CYLINDERS ONLY</i>)	-
4	500-2-0941	SCALPER MOUNT INNER	-
5	500-2-0942	SCALPER MOUNT OUTER	-
6	500-2-0684	1-1/4" PIN WELDMENT	-
7	500-3-3019	SCALPER TUBE - (1222)	2
	500-3-2184	SCALPER TUBE - (922)	1
	500-3-2183	SCALPER TUBE - (630, 822)	1
	500-3-3023	SCALPER TUBE - (430, 622)	1
8	900-01223	1/2 NC X 1-1/2 HEX BOLT GR5	-
9	900-01437	3/4 NC X 8-1/2 HEX BOLT GR5	-
10	900-03463	3/4-10 EYE BOLT	-
11	500-3-0635	3/4-10 X 4 A BOLT	-
12	900-06015	HEX NUT - 3/4 NC	-
13	900-06143	1/2 NC SPIRALOCK NUT GR5 ZP	-
14	900-11017	LOCK WASHER, 3/4	-
15	900-11038	WASHER, 3/4	-
16	900-11035	WASHER, 1/2	-
17	900-02356	BOLT, 5/16 NC X 1-3/4 GR5 ZP	-
18	900-31068	COVER PLATE AND BOLT	-
19	900-31069	CLAMP BODY	-

SCALPER TOOLBAR COMPONENTS - STRAIGHT ARM

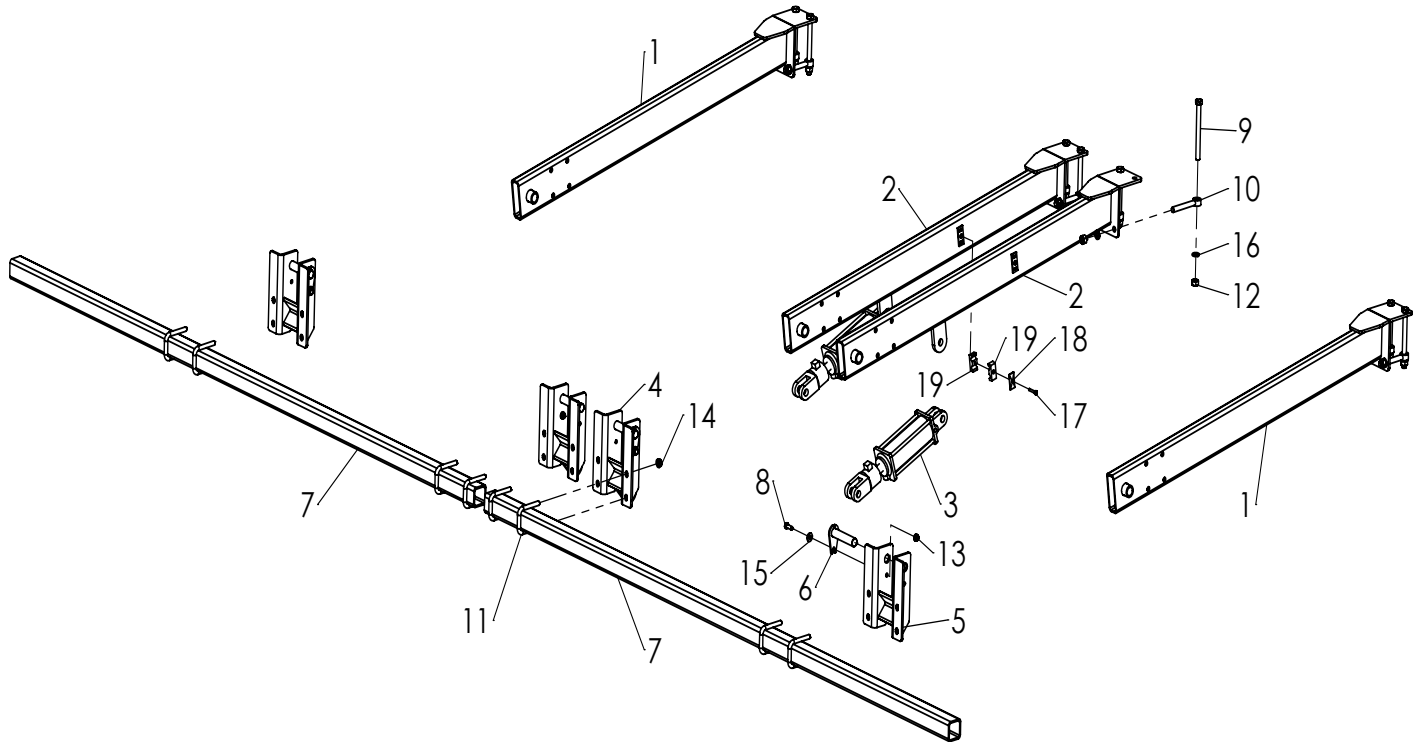

ITEM NO.	PART NUMBER	DESCRIPTION	QTY.
1	500-2-1437	OUTER SETBACK ARM WELDMENT (LARGE TIRES)	-
	500-2-1040	OUTER SETBACK ARM WELDMENT (SMALL TIRES)	-
2	500-2-1436	INNER SETBACK ARM WELDMENT (LARGE TIRES)	-
	500-2-1041	INNER SETBACK ARM WELDMENT (SMALL TIRES)	-
3	905-21400	HYDRAULIC CYLINDER - 3.5 X 8	-
	905-21380	- SEAL KIT (<i>PRINCE CYLINDERS ONLY</i>)	-
	905-21401	- SEAL KIT (<i>MONARCK CYLINDERS ONLY</i>)	-
4	500-2-1439	SCALPER MOUNT INNER	-
5	500-2-1440	SCALPER MOUNT OUTER	-
6	500-2-0684	1-1/4" PIN WELDMENT	-
7	500-3-1579	SCALPER TUBE - (1222)	2
	500-3-2182	SCALPER TUBE - (922)	1
	500-3-2181	SCALPER TUBE - (630, 822)	1
	500-3-2965	SCALPER TUBE - (430, 622)	1
8	900-01223	1/2 NC X 1-1/2 HEX BOLT GR5	-
9	900-01437	3/4 NC X 8-1/2 HEX BOLT GR5	-
10	900-03463	3/4-10 EYE BOLT	-
11	900-35026	U-BOLT, 5/8 NC X 4-1/2 LONG	-
12	900-06015	HEX NUT - 3/4 NC	-
13	900-06143	1/2 NC SPIRALOCK NUT GR5 ZP	-
14	900-06145	NUT, SPIRALOCK FLANGE 5/8 NC, GR8	-
15	900-11035	WASHER, 1/2	-
16	900-11017	LOCK WASHER, 3/4	-
17	900-02356	BOLT, 5/16 NC X 1-3/4 GR5 ZP	-
18	900-31068	COVER PLATE AND BOLT	-
19	900-31069	CLAMP BODY	-

STABILIZER WHEEL COMPONENTS

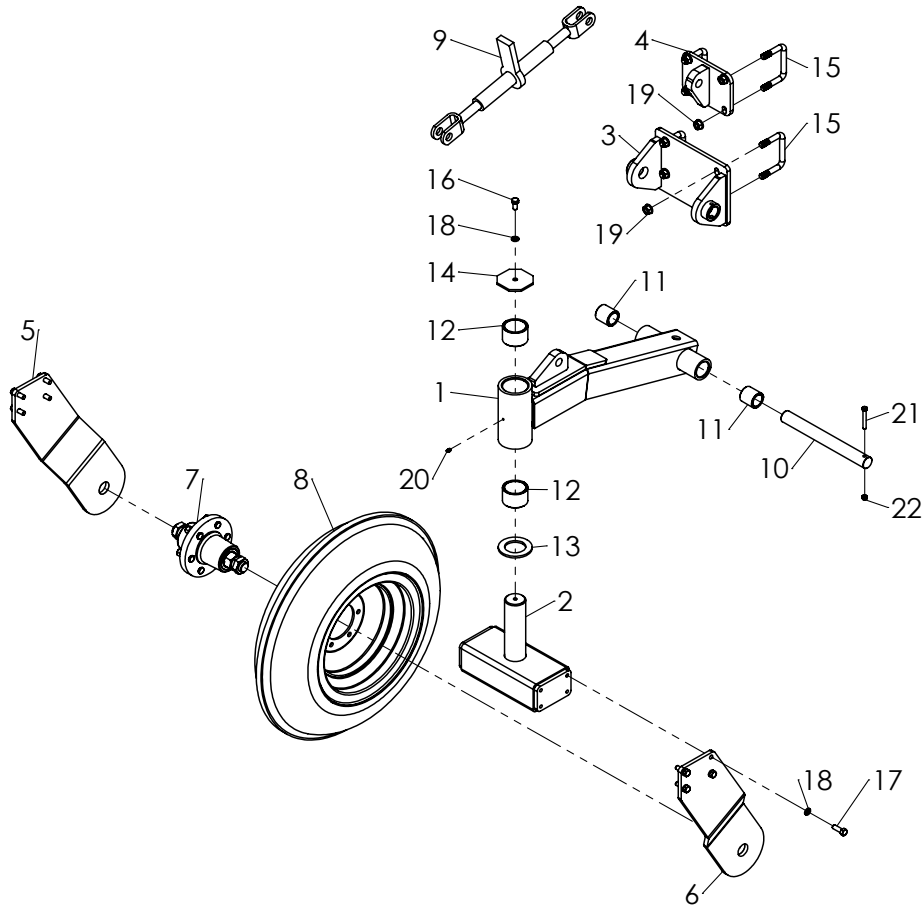

ITEM NO.	PART NUMBER	DESCRIPTION	QTY.
1	500-2-1328	STABILIZER WHEEL ARM	1
2	200-2-0689	CASTER PIVOT	1
3	500-2-1310	LOWER MOUNT	1
4	500-2-1311	UPPER MOUNT	1
5	200-3-2621	SIDE PLATE (LH)	1
6	200-3-2622	SIDE PLATE (RH)	1
7	200-2-0928	HUB & SPINDLE ASSEMBLY	1
8	200-2-0988	MONORIB TIRE & RIM ASSEMBLY	1
9	905-23014	RATCHET JACK	1
10	700-3-2600	PIVOT PIN	1
11	500-3-1151	BRONZE BUSHING	2
12	200-3-1766	OILITE BUSHING	2
13	200-3-1233	OILITE WASHER	1
14	200-3-1219	RETAINER PLATE	1
15	200-3-4641	U-BOLT, 5/8 NC x 4 x 3-1/4	4
16	900-01221	BOLT, 1/2 NC x 1	1
17	900-01225	BOLT, 1/2 NC x 1-1/2	8
18	900-11013	WASHER, LOCK 1/2	9
19	900-06145	NUT, SPIRALOCK 5/8 NC	8
20	905-15024	GREASE ZERK, 1/4-28 UNF STRAIGHT	1
21	900-01123	BOLT, 3/8 NC, 2-3/4	1
22	900-06500	NUT, TOP LOCK, 3/8 NC	1
-	500-2-1309	FRONT STABILIZER WHEEL ASSEMBLY	-

STABILIZER WHEEL HUB COMPONENTS

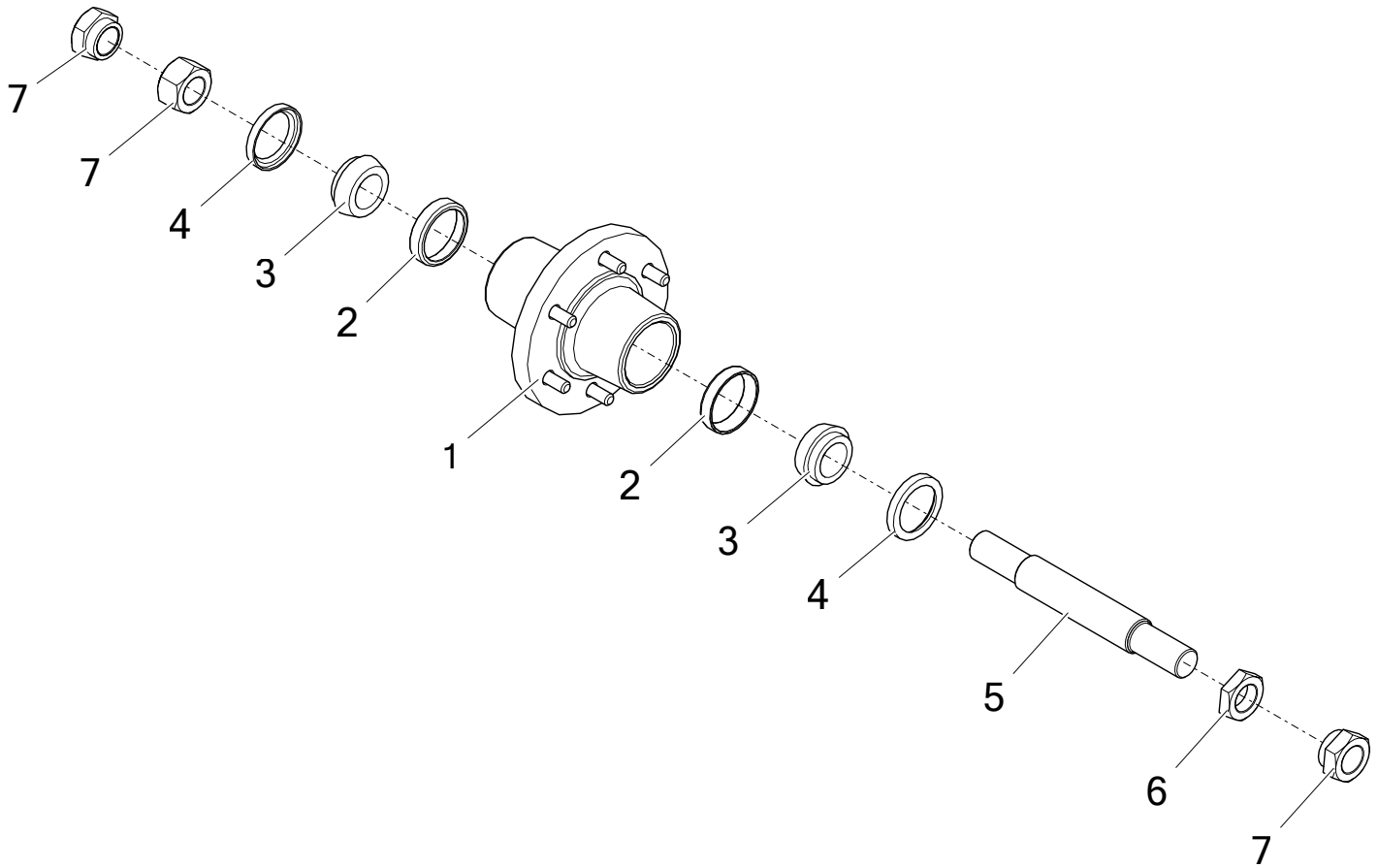

ITEM NO.	PART NUMBER	DESCRIPTION	QTY.
1	905-09082	HUB W/ CUPS	1
2	901-01148	BEARING CUP	2
3	901-01149	BEARING CONE	2
4	901-09127	SEAL	2
5	200-3-1240	FORK SPINDLE	1
6	200-3-2726	SHORT NUT, 1-1/4 NC	1
7	900-06024	NUT, 1-1/4 NC	3
-	200-2-0928	HUB & SPINDLE (COMPLETE KIT)	-

HUB & SPINDLE ASSEMBLY COMPONENTS

700-2-0165
8-BOLT HUB ASSEMBLY

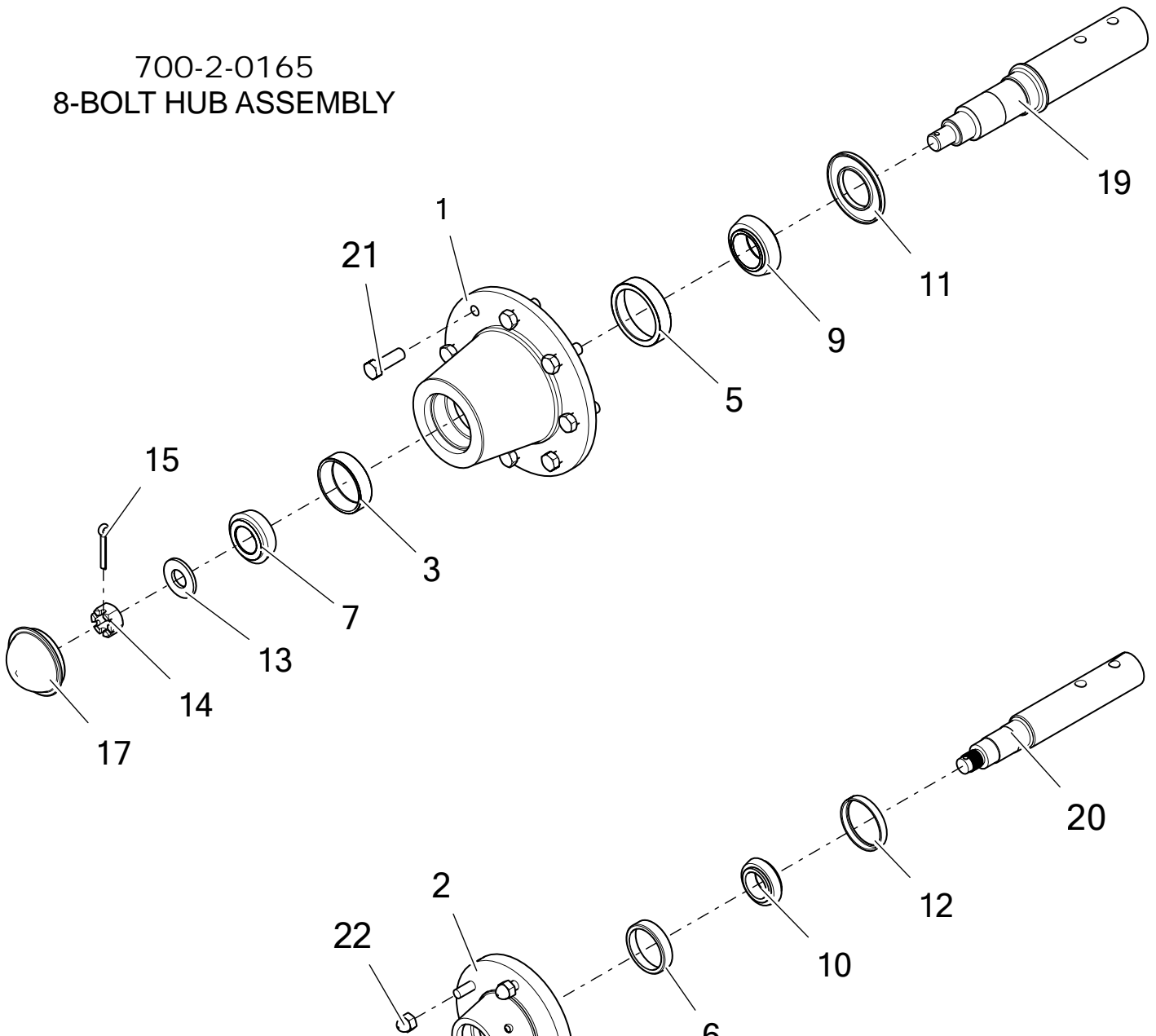

500-2-0972
5-BOLT HUB ASSEMBLY

HUB & SPINDLE ASSEMBLY COMPONENTS

ITEM NO.	PART NUMBER	DESCRIPTION	QTY.
1	905-09182	HUB (8-BOLT)	1
2	905-09174	HUB (5-BOLT)	1
3	901-01324	BEARING CUP (25821)	1
4	901-01016	BEARING CUP (LM67010)	1
5	901-01152	BEARING CUP (25520)	1
6	901-01022	BEARING CUP (LM48510)	1
7	901-01326	BEARING CONE (25877)	1
8	901-01015	BEARING CONE (LM67048)	1
9	901-01325	BEARING CONE (25590)	1
10	901-01023	BEARING CONE (LM48548)	1
11	901-09215	GREASE SEAL (CR20148)	1
12	901-09002	GREASE SEAL (17273VHY-BX)	1
13	905-09067	WASHER, 7/8 SAE	1
14	900-06060	NUT, SLOTTED, 7/8 NF	1
15	900-23064	PIN, COTTER, 1/4 x 2	1
16	900-23045	PIN, COTTER, 3/16 x 2	1
17	905-09135	HUB CAP (DC17)	1
18	905-09009	HUB CAP (DC13)	1
19	700-3-0143	SPINDLE (8-BOLT)	1
20	500-3-2151	SPINDLE (5-BOLT)	1
21	905-09039	WHEEL BOLT, 9/16 NF x 1-11/16	8
22	905-09011	WHEEL NUT, 1/2 NF	5
-	905-09003	HUB - 5 BOLT INCLUDES: #2, #4, #6	-
-	905-09136	HUB - 8 BOLT INCLUDES: #1, #3, #5	-
-	100-2-1051	HUB ASSEMBLY - 5 BOLT INCLUDES: #2, #4, #6, #8, #10, #12, #18	-
-	905-09128	HUB ASSEMBLY - 8 BOLT INCLUDES: #1, #3, #5, #7, #9, #11, #17	-
-	500-2-0972	HUB & SPINDLE ASSEMBLY - 5 BOLT	-
-	700-2-0165	HUB & SPINDLE ASSEMBLY - 8 BOLT	-

ROW FINDER COMPONENTS

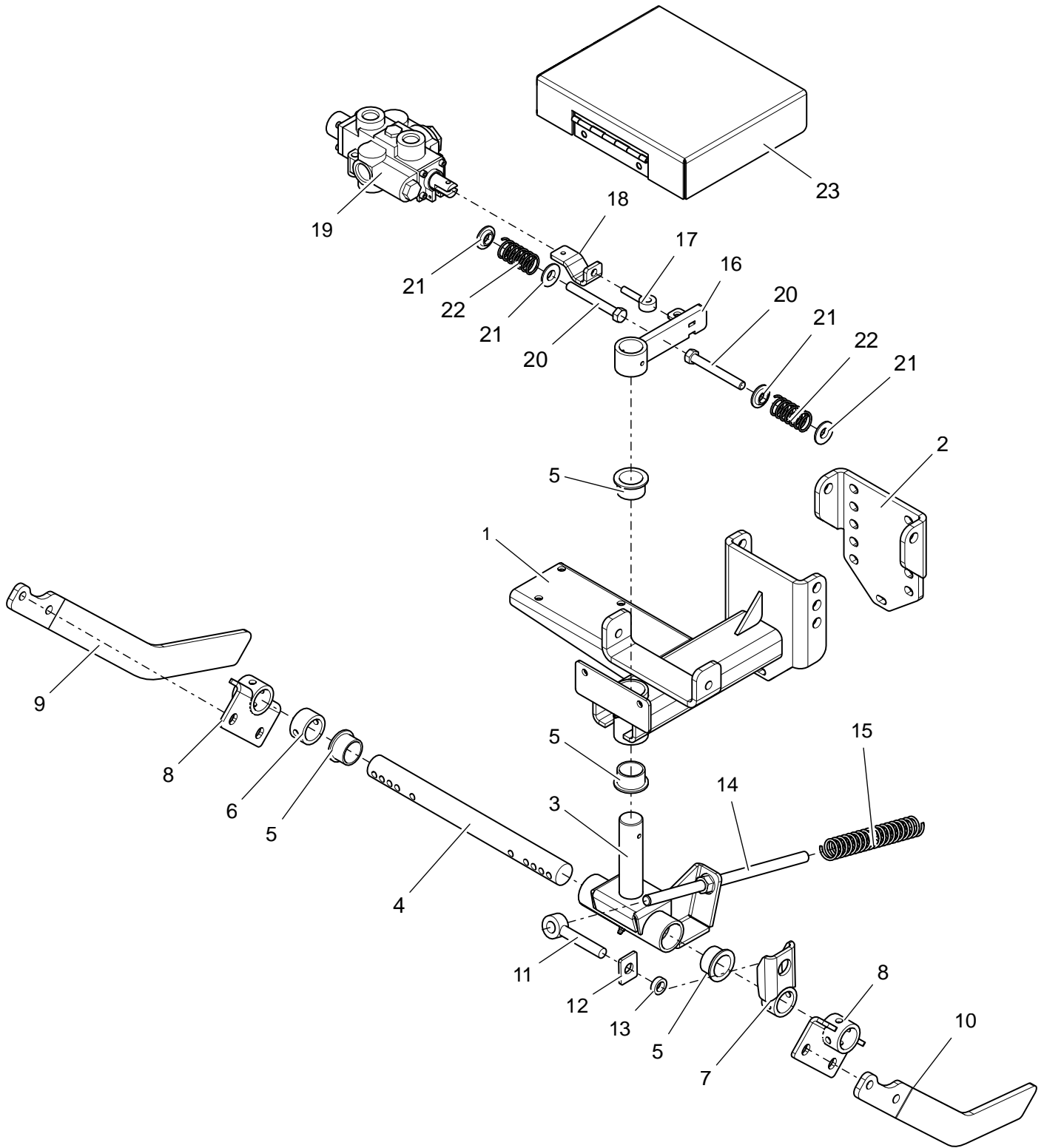

ROW FINDER COMPONENTS

ITEM NO.	PART NUMBER	DESCRIPTION	QTY.
1	500-2-1249	PIVOT MOUNT	1
2	700-3-2186	INNER PIVOT MOUNT	1
3	700-2-0851	BOTTOM PIVOT	1
4	700-3-2170	PIVOT SHAFT	1
5	700-3-0383	BUSHING (OILITE)	4
6	700-3-2182	LOCK COLLAR	1
7	700-2-0853	SPRING TENSIONER	1
8	700-2-0854	FINGER MOUNT	2
9	700-3-2188	FINGER (LH)	1
10	700-3-2189	FINGER (RH)	1
11	900-03465	EYE BOLT	1
12	700-3-2187	INSIDE WASHER	1
13	700-3-2183	BUSHING (TENSIONER)	1
14	700-2-0856	TENSIONER ROD	1
15	905-14007	TENSIONER SPRING	1
16	700-2-0850	STEERING PADDLE	1
17	903-05044	ROD END EYE BOLT	1
18	700-3-2343	ADJUSTMENT PLATE	1
19	905-03262	CONTROL VALVE	1
20	900-01245	BOLT, 1/2 NC x 4	2
21	700-3-2185	SPRING RETAINER	4
22	905-14022	SPRING	2
23	500-2-1250	TOP COVER	1
-	500-2-1248	ROWFINDER COMPLETE ASSEMBLY	-

TOOLBAR ROW FINDER COMPONENTS

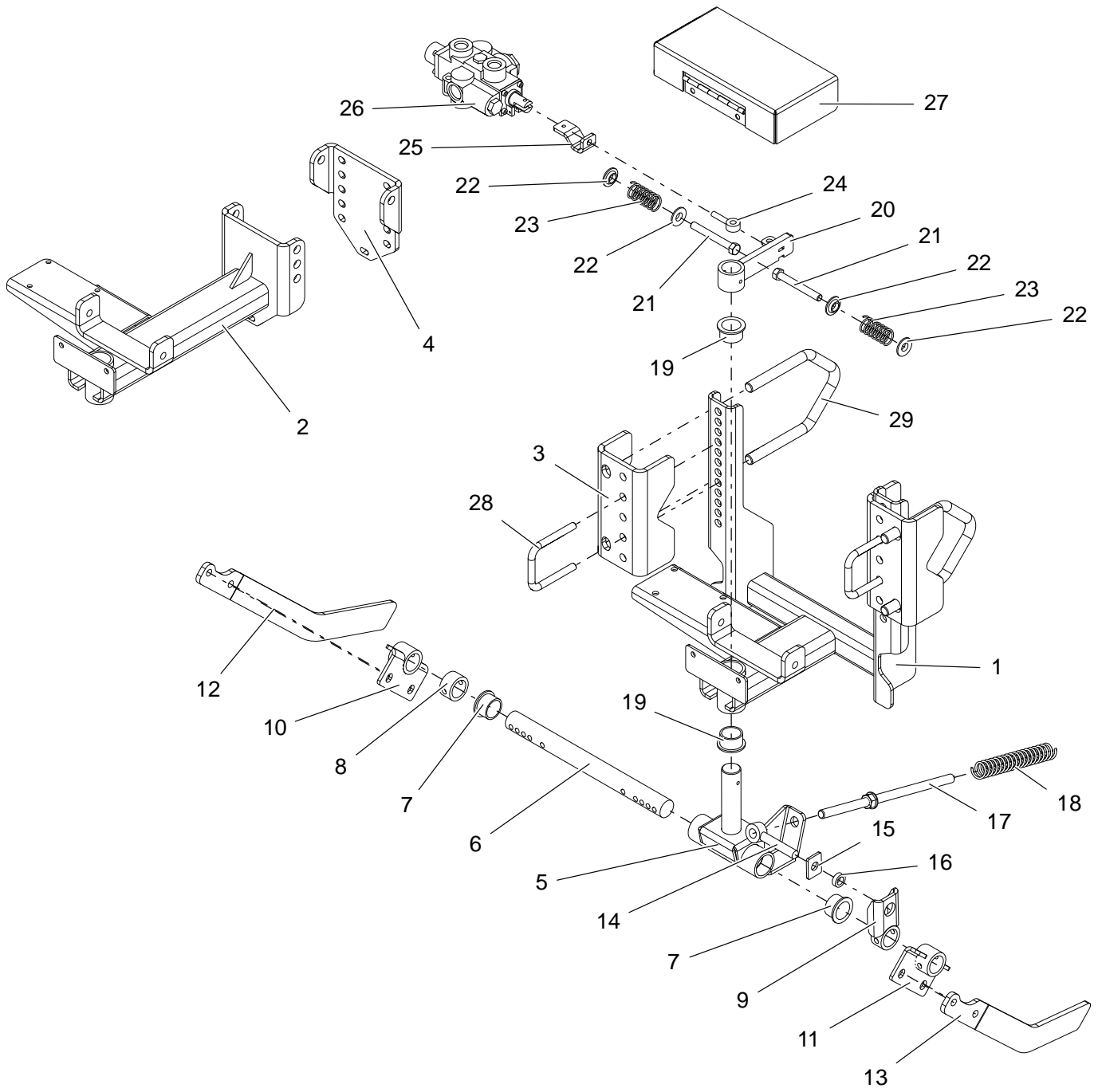

TOOLBAR ROW FINDER COMPONENTS

ITEM NO.	PART NUMBER	DESCRIPTION	QTY.
1	500-2-1168	PIVOT MOUNT	1
2	700-2-0851	BOTTOM PIVOT	1
3	700-3-2170	PIVOT SHAFT	1
4	700-3-0383	BUSHING (OILITE)	4
5	700-3-2182	LOCK COLLAR	1
6	700-2-0853	SPRING TENSIONER	1
7	700-2-0854	FINGER MOUNT	2
8	700-3-2188	FINGER (LH)	1
9	700-3-2189	FINGER (RH)	1
10	700-2-0856	TENSIONER ROD	1
11	905-14007	TENSIONER SPRING	1
12	700-3-2187	INSIDE WASHER	1
13	700-3-2183	BUSHING (TENSIONER)	1
14	900-03465	EYE BOLT	1
15	700-2-0850	STEERING PADDLE	1
16	500-3-1578	U-BOLT, 1/2NC x 3 x 4	2
17	500-3-0635	A-BOLT, 3/4NC x 4 x 4	2
18	903-05044	ROD END EYE BOLT	1
19	700-3-2343	ADJUSTMENT PLATE	1
20	905-03262	CONTROL VALVE	1
21	900-01245	BOLT, 1/2 NC x 4	2
22	700-3-2185	SPRING RETAINER	4
23	905-14022	SPRING	2
24	500-3-2548	ADAPTER MOUNT	2
25	700-2-0908	TOP COVER	1
-	500-2-1169	ROWFINDER COMPLETE ASSEMBLY	-

STRAIGHT ARM SCALPER ROW FINDER COMPONENTS

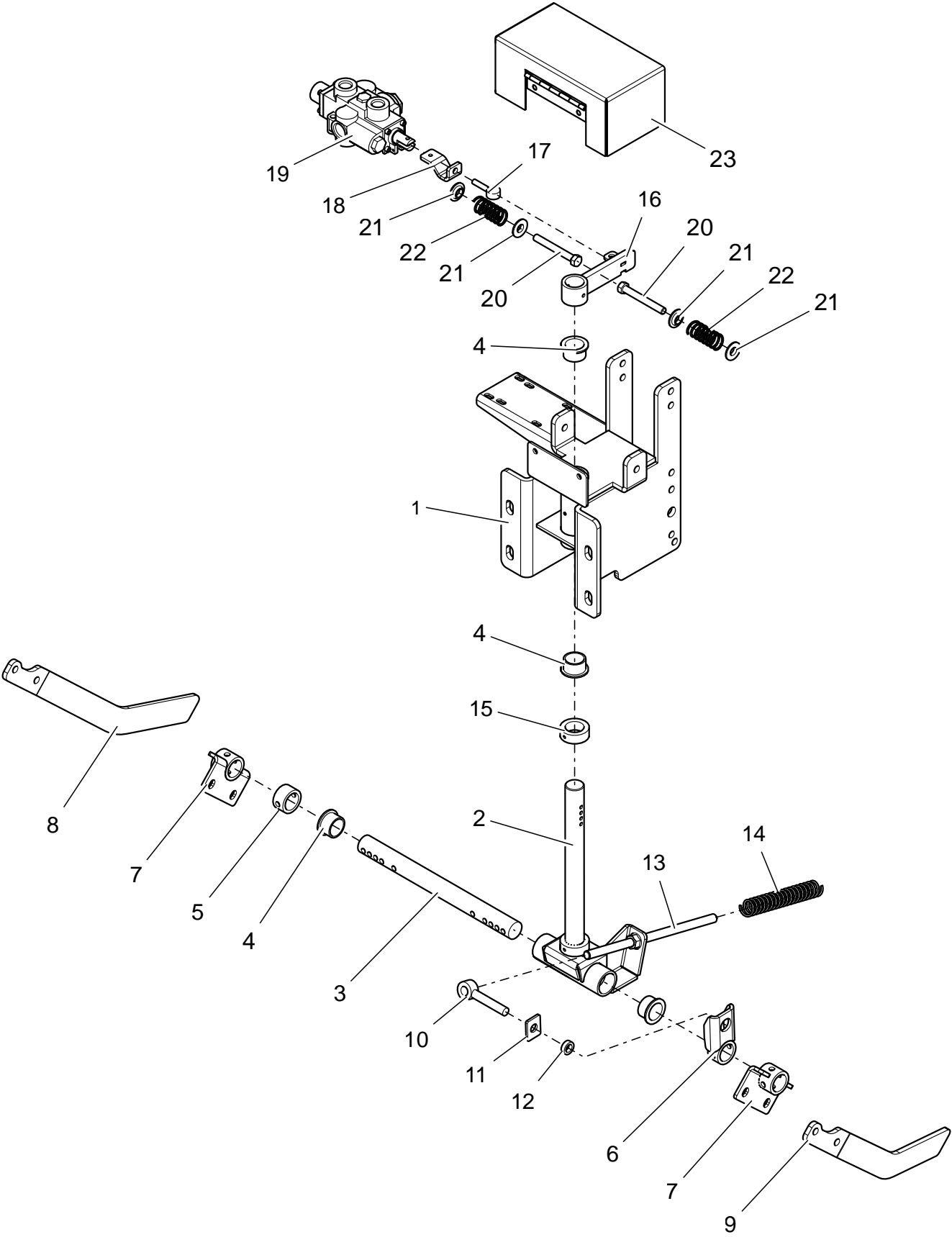

STRAIGHT ARM SCALPER ROW FINDER COMPONENTS

ITEM NO.	PART NUMBER	DESCRIPTION	QTY.
1	500-2-1259	PIVOT MOUNT	1
2	500-2-1258	BOTTOM PIVOT	1
3	700-3-2170	PIVOT SHAFT	1
4	700-3-0383	BUSHING (OILITE)	4
5	700-3-2182	LOCK COLLAR	1
6	700-2-0853	SPRING TENSIONER	1
7	700-2-0854	FINGER MOUNT	2
8	700-3-2188	FINGER (LH)	1
9	700-3-2189	FINGER (RH)	1
10	900-03465	EYE BOLT	1
11	700-3-2187	INSIDE WASHER	1
12	700-3-2183	BUSHING (TENSIONER)	1
13	700-2-0856	TENSIONER ROD	1
14	905-14007	TENSIONER SPRING	1
15	901-01323	LOCK COLLAR, 1-3/8"	1
16	700-2-0850	STEERING PADDLE	1
17	903-05044	ROD END EYE BOLT	1
18	700-3-2343	ADJUSTMENT PLATE	1
19	905-03262	CONTROL VALVE	1
20	900-01245	BOLT, 1/2 NC x 4	2
21	700-3-2185	SPRING RETAINER	4
22	905-14022	SPRING	2
23	500-2-1269	ROP COVER	1
-	500-2-1257	ROWFINDER COMPLETE ASSEMBLY	-

PARALLEL LINK SCALPER ROW FINDER COMPONENTS

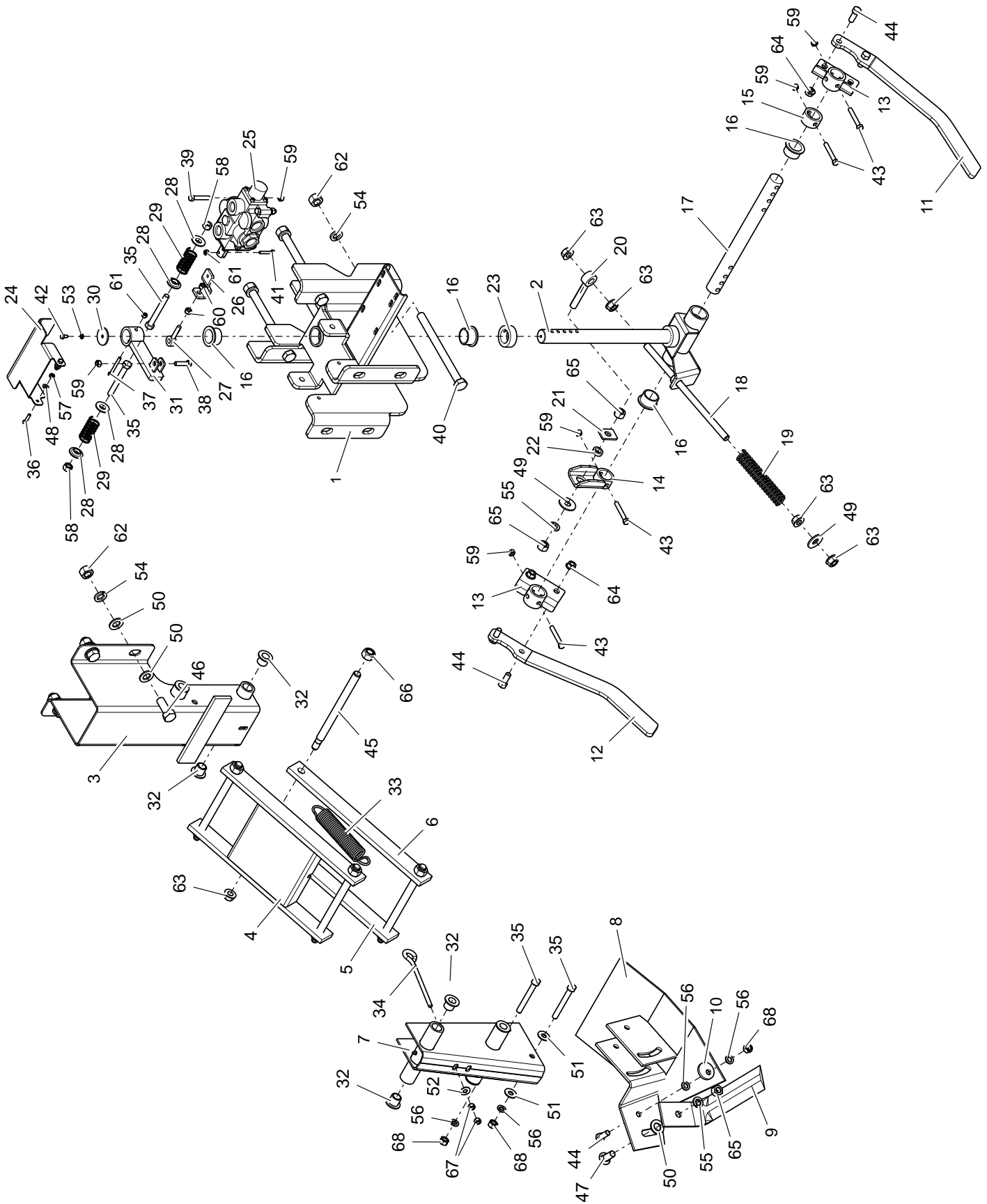

PARALLEL LINK SCALPER ROW FINDER COMPONENTS

ITEM NO.	PART NUMBER	DESCRIPTION	QTY.
1	500-2-1380	PARALLEL LINK PIVOT MOUNT	1
2	500-2-1258	BOTTOM PIVOT	1
3	500-2-1378	PARALLEL LINK MOUNT	1
4	500-2-0518	"H" LINKAGE ARM	1
5	500-3-0991	LINKAGE ARM (LH)	1
6	500-3-0992	LINKAGE ARM (RH)	1
7	500-2-0338	LOWER SHOE MOUNT	1
8	500-2-0335	SHOE (LH)	1
	500-2-0336	SHOE (RH)	
9	500-3-0910	KNIFE SCALPER	1
10	500-3-0201	ECCENTRIC SPACER	1
11	700-3-2188	SHORT FINGER (LH)	1
	500-3-2934	EXTENDED FINGER (LH)	
	500-3-2937	LONG FINGER (LH)	
12	700-3-2189	SHORT FINGER (RH)	1
	500-3-2933	EXTENDED FINGER (RH)	
	500-3-2936	LONG FINGER (RH)	
13	700-2-0854	FINGER MOUNT	2
14	700-2-0853	SPRING TENSIONER	1
15	700-3-2182	LOCK COLLAR	1
16	700-3-0383	OILITE BUSHING	4
17	700-3-2170	PIVOT SHAFT	1
18	700-2-0856	TENSIONER ROD	1
19	905-14007	TENSIONER SPRING	1
20	900-03465	EYE BOLT	1
21	700-3-2187	INSIDE WASHER	1
22	700-3-2183	BUSHING (TENSIONER)	1
23	901-01323	LOCK COLLAR, 1-3/8"	1
24	500-3-2704	TOP COVER	1
25	905-03262	CONTROL VALVE	1
26	700-3-2343	ADJUSTMENT PLATE	1
27	903-05044	ROD END EYE BOLT	1
28	700-3-2185	SPRING RETAINER	4
29	905-14022	SPRING	2
30	500-3-2705	DROP PLATE	1
31	700-2-0850	STEERING PADDLE	1
32	200-3-0877	FLANGED BUSHING	8
33	400-3-0263	EXTENSION SPRING	1
34	500-3-0675	EYE BOLT, 3/8" x 8	1
35	900-01245	BOLT, 1/2 NC x 4	4
36	900-01009	BOLT, 1/4 NC x 1	2
37	900-03112	BOLT, 1/4 NC x 2-1/4	1
38	900-01113	BOLT, 3/8 NC x 1-1/2	1
39	900-01117	BOLT, 3/8 NC x 2	3

PARALLEL LINK SCALPER ROW FINDER COMPONENTS

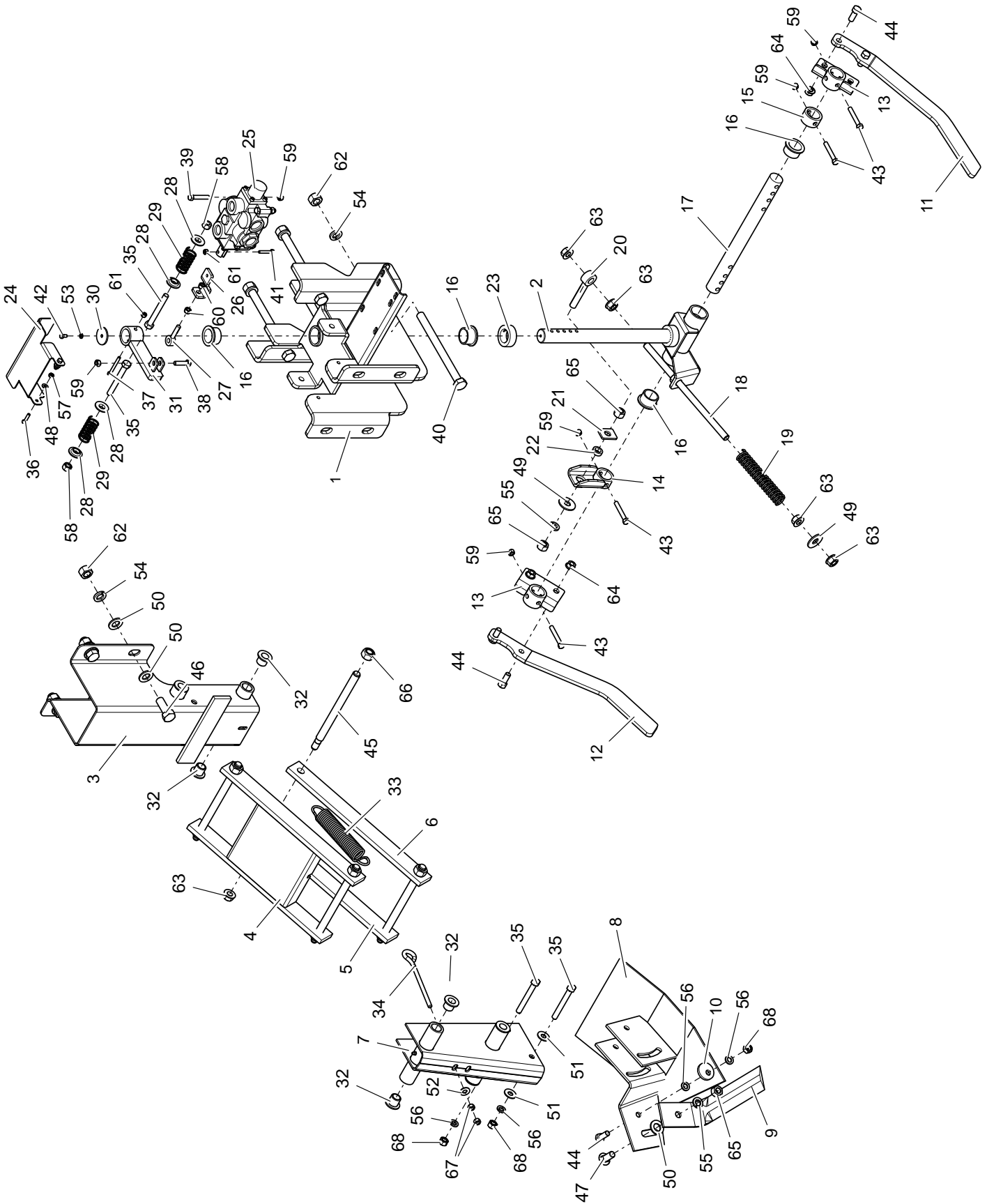

PARALLEL LINK SCALPER ROW FINDER COMPONENTS

ITEM NO.	PART NUMBER	DESCRIPTION	QTY.
40	900-01441	BOLT, 3/4 NC x 9-1/2	4
41	900-01013	BOLT, 1/4 NC x 1-1/2	1
42	900-01001	BOLT, 1/4 NC x 1/2	1
43	900-01121	BOLT, 3/8 NC x 2-1/2	4
44	900-01223	BOLT, 1/2 NC x 1-1/4	5
45	200-3-2631	PARALLEL LINKAGE PIN	4
46	900-01403	BOLT, 3/4 NC x 2	4
47	900-01784	BOLT, CARRIAGE, 5/8 NC x 1-1/2	1
48	900-11031	WASHER, 1/4	2
49	900-11037	WASHER, 5/8	2
50	900-11038	WASHER, 3/4	9
51	900-11035	WASHER, 1/2	2
52	900-11033	WASHER, 3/8	1
53	900-11009	WASHER, LOCK, 1/4	1
54	900-11017	WASHER, LOCK, 3/4	8
55	900-11015	WASHER, LOCK, 5/8	2
56	900-11013	WASHER, LOCK, 1/2	4
57	900-06001	NUT, 1/4 NC	2
58	900-06504	NUT, TOP LOCK, 1/2 NC	2
59	900-06500	NUT, TOP LOCK, 3/8 NC	8
60	900-06006	NUT, 3/8 NF	2
61	900-06496	NUT, TOP LOCK, 1/2 NC	2
62	900-06015	NUT, 3/4 NC	8
63	900-06145	NUT, SPIRALOCK, 5/8 NC	9
64	900-06143	NUT, SPIRALOCK, 1/2 NC	4
65	900-06013	NUT, 5/8 NC	3
66	900-06510	NUT, TOP LOCK, 3/4 NC	4
67	900-06005	NUT, 3/8 NC	2
68	900-06009	NUT, 1/2 NC	3

ROWFINDER PARALLEL LINK MOUNT

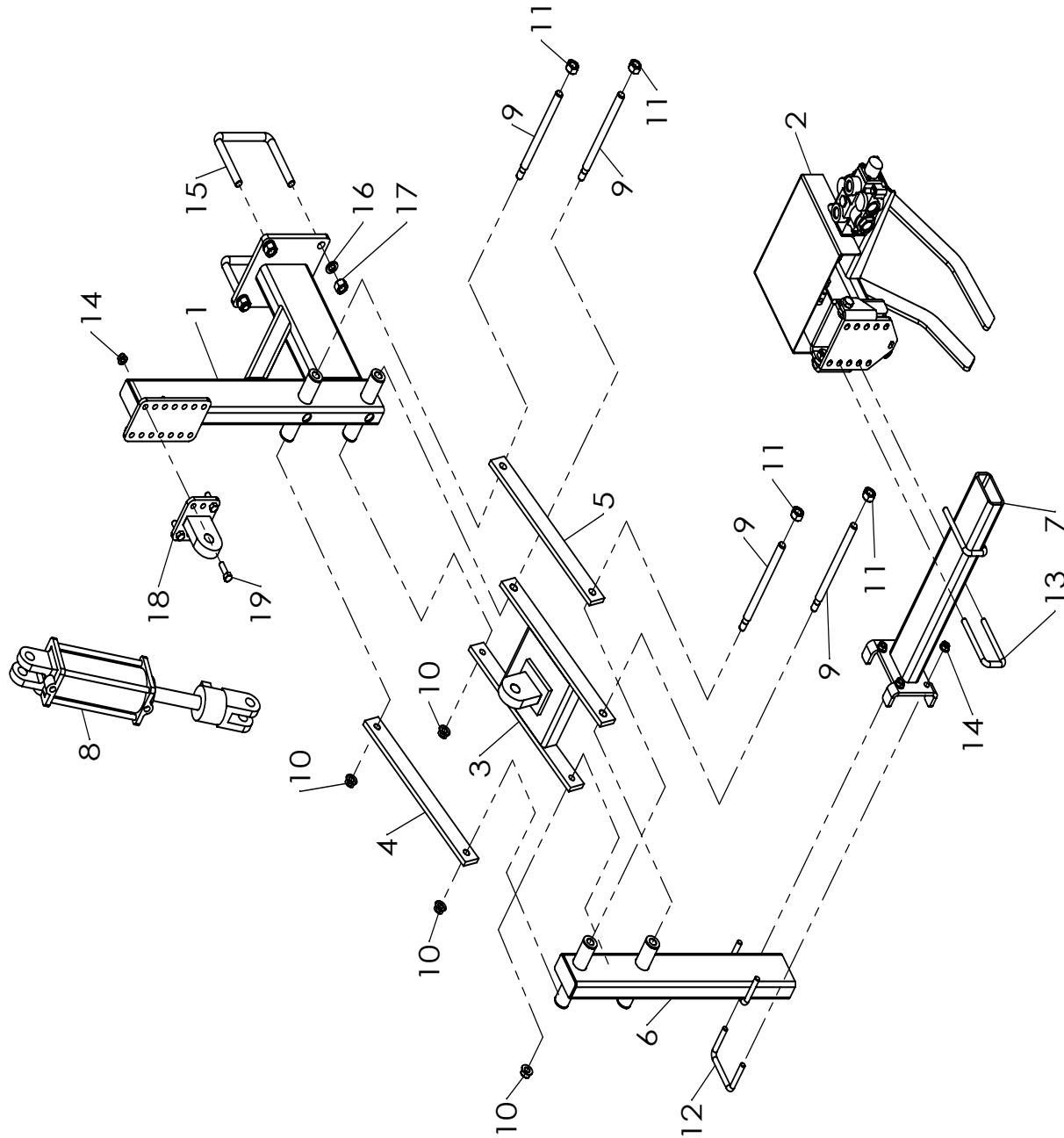

ROWFINDER PARALLEL LINK MOUNT

ITEM NO.	PART NUMBER	DESCRIPTION	QTY.
1	500-2-1080	UPPER MOUNT	1
2	500-2-1248	ROWFINDER	1
3	500-2-1081	H-ARM	1
4	500-3-0991	CONNECTING ARM (5/8" HOLES)	1
5	500-3-0992	CONNECTING ARM (3/4" HOLES)	1
6	500-2-1079	LOWER MOUNT	1
7	500-2-1029	HORIZONTAL MOUNT	1
8	905-21400	CYLINDER, 3-1/2 x 8	1
	905-21380	- SEAL KIT (<i>PRINCE CYLINDERS ONLY</i>)	
	905-21401	- SEAL KIT (<i>MONARCK CYLINDERS ONLY</i>)	
9	200-3-2631	PARALLEL LINK PIN	4
10	900-06145	SPIRALOCK NUT, 5/8 NC	4
11	900-06510	TOP LOCK NUT, 3/4 NC	4
12	200-3-1445	U-BOLT, 1/2 NC x 4 x 3	2
13	200-3-1447	U-BOLT, 1/2 NC x 2 x 5-1/4	2
14	900-06143	SPIRALOCK NUT, 1/2 NC	12
15	200-3-0024	U-BOLT, 3/4 NC x 6 x 5-1/2	2
16	900-11017	LOCK WASHER, 3/4	4
17	900-06015	NUT, 3/4 NC	4
18	500-2-1474	ADJUSTABLE CYLINDER EAR WELD	1
19	900-01225	BOLT, 1/2 NC X 1-1/2	4
-	500-1-0182	ROW FINDER REAR TUBE MOUNT KIT	-

ROWFINDER PARALLEL LINK MOUNT (44" STRUTS)

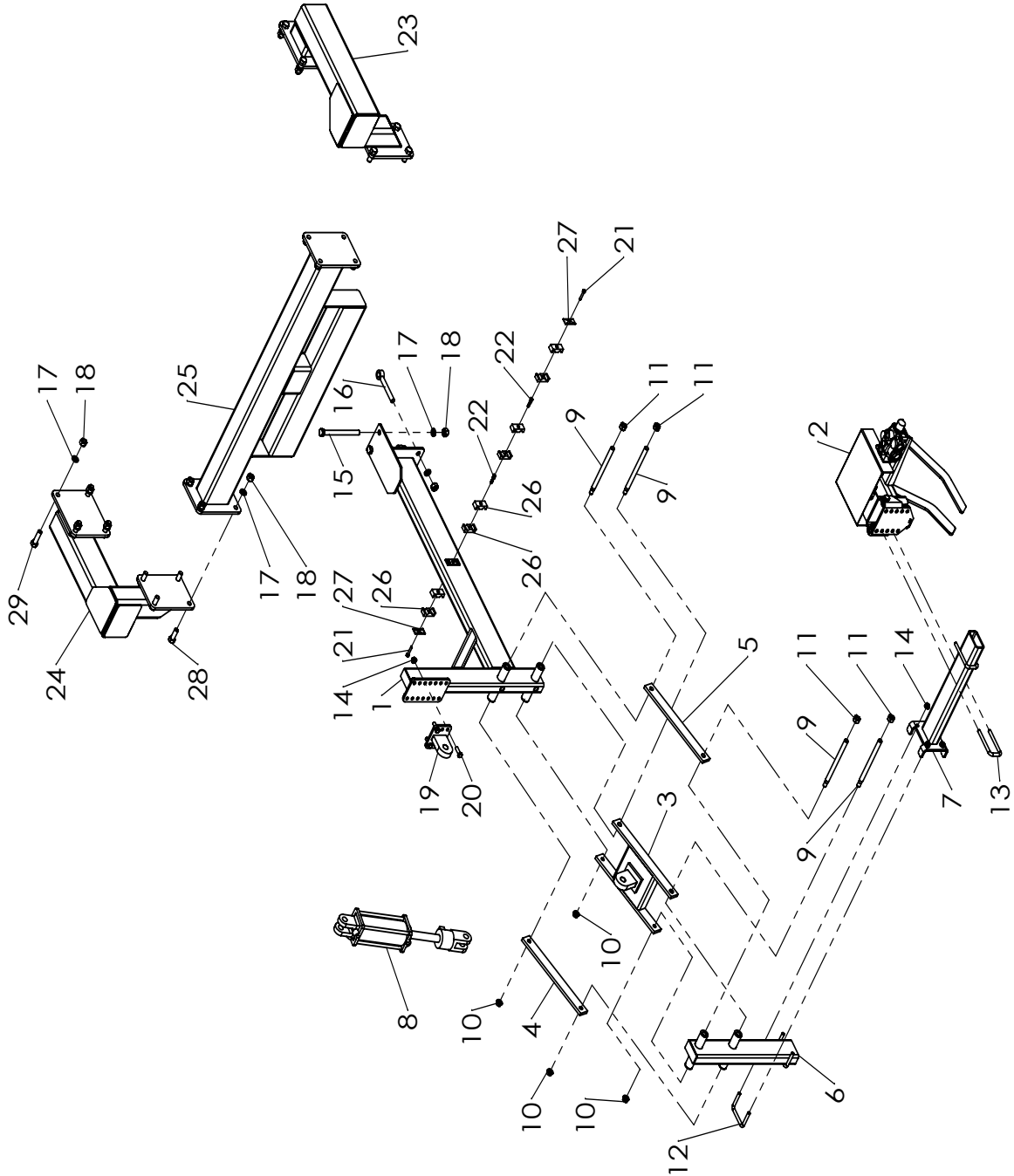

ROWFINDER PARALLEL LINK MOUNT (44" STRUTS)

ITEM NO.	PART NUMBER	DESCRIPTION	QTY.
1	500-2-1254	UPPER MOUNT	1
2	500-2-1248	ROW FINDER	1
3	500-2-1081	H-ARM	1
4	500-3-0991	CONNECTING ARM (5/8" HOLES)	1
5	500-3-0992	CONNECTING ARM (3/4" HOLES)	1
6	500-2-1255	LOWER MOUNT	1
7	500-2-1029	HORIZONTAL MOUNT	1
8	905-21400	CYLINDER, 3-1/2" x 8	1
	905-21380	- SEAL KIT (<i>PRINCE CYLINDERS ONLY</i>)	
	905-21401	- SEAL KIT (<i>MONARCK CYLINDERS ONLY</i>)	
9	200-3-2631	PARALLEL LINK PIN	4
10	900-06145	SPIRALOCK NUT, 5/8 NC	4
11	900-06510	TOP LOCK NUT, 3/4 NC	4
12	200-3-1445	U-BOLT, 1/2 NC x 4 x 3	2
13	200-3-1447	U-BOLT, 1/2 NC x 2 x 5-1/4	2
14	900-06143	SPIRALOCK NUT, 1/2 NC	12
15	900-01437	BOLT, 3/4 NC x 8-1/2	2
16	900-03463	EYE BOLT, 3/4 NC x 6	2
17	900-11017	LOCK WASHER, 3/4	20
18	900-06015	NUT, 3/4 NC	20
19	500-2-1474	ADJUSTABLE CYLINDER EAR WELD	1
20	900-01225	BOLT, 1/2 NC X 1-1/2	4
21	900-02356	BOLT, 5/16 NC X 1-3/4	2
22	900-31071	BOLT, STACKING 5/16 UNC	2
23	500-2-1233	SCALPER SET BACK WELD - RH	1
24	500-2-1231	SCALPER SET BACK WELD - LH	1
25	500-2-1234	SCALPER CROSS TUBE WELD	1
26	900-31069	CLAMP BODY	8
27	900-31068	COVER PLATE AND BOLT	2
28	900-01403	BOLT, 3/4 NC X 2	8
29	900-01407	BOLT, 3/4 NC X 2-1/2	8
-	500-1-0366	ROW FINDER REAR TUBE MOUNT KIT (<i>44" STRUTS</i>)	-

REAR STEER HYDRAULIC COMPONENTS

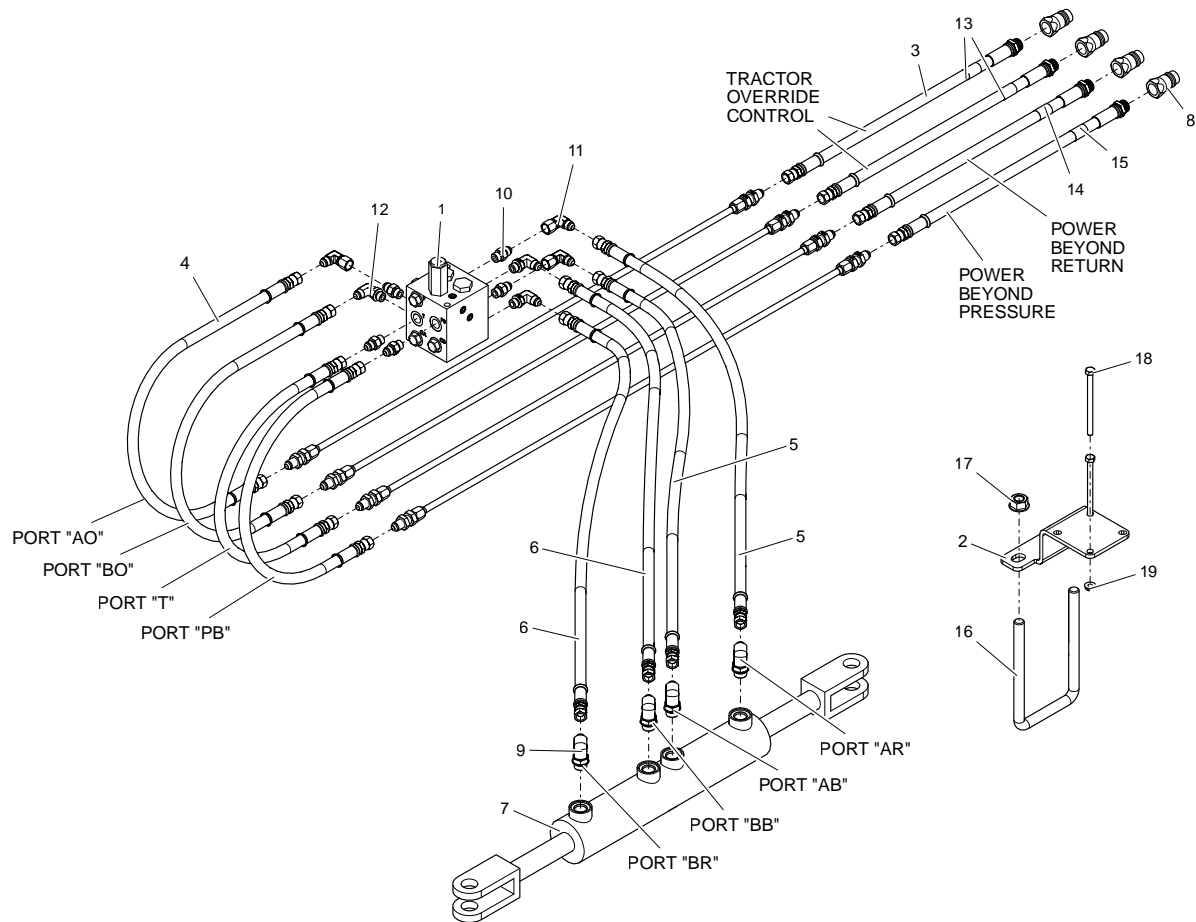

ITEM NO.	PART NUMBER	DESCRIPTION	QTY.
1	905-03263	SELF-CENTERING REAR STEER MANIFOLD	1
2	500-3-2619	MANIFOLD MOUNT	1
3	905-19154	HOSE, 3/8 x 115.0, 8MB x 6FJX (<i>SHORT HITCH</i>)	4
	905-19139	HOSE, 3/8 x 150.0, 8MB x 6FJX (<i>LONG HITCH</i>)	4
4	905-19118	HOSE, 3/8 x 36.00, 6FJX x 6FJX	4
5	905-19193	HOSE, 3/8 x 106.0, 6FJX x 6FJX	2
	905-19255	HOSE, 3/8 x 76.0, 6FJX x 6FJX	2
6	905-19182	HOSE, 3/8 x 114.0, 6FJX x 6FJX	2
	905-19152	HOSE, 3/8 x 84.0, 6FJX x 6FJX	2
7	905-21452	DOUBLE CYLINDER, 1-1/4 x 2-1/2 x 4	1
8	905-19126	QUICK COUPLER	4
9	905-03114	ADAPTER, 90° ELBOW, 6MJ x 8MB	4
10	905-03120	ADAPTER, STRAIGHT, 6MJ x 6MB	5
11	905-03163	ADAPTER, 90° ELBOW, 6MJ x 6FJX	3
12	905-03264	ADAPTER, 90° ELBOW, 6MJ x 6MB	3
13	500-3-2837	ORANGE HOSE LABEL	2
14	500-3-2843	WHITE HOSE LABEL	1
15	500-3-2842	GREY HOSE LABEL	1
16	200-3-0017	U-BOLT, 5/8 NC x 4 x 7-1/4	2
17	900-06145	NUT, SPIRALOCK, 5/8 NC	2
18	900-01085	BOLT, 5/16 NC x 4-1/2	2
19	900-06137	NUT, SPIRALOCK, 5/16 NC	2
-	500-1-0417	HOSE KIT, REAR STEER (88"-110") <i>*DOES NOT INCLUDE CYLINDER*</i>	-
-	500-1-0418	HOSE KIT, REAR STEER (132"-154") <i>*DOES NOT INCLUDE CYLINDER*</i>	-

ROW FINDER HYDRAULIC COMPONENTS

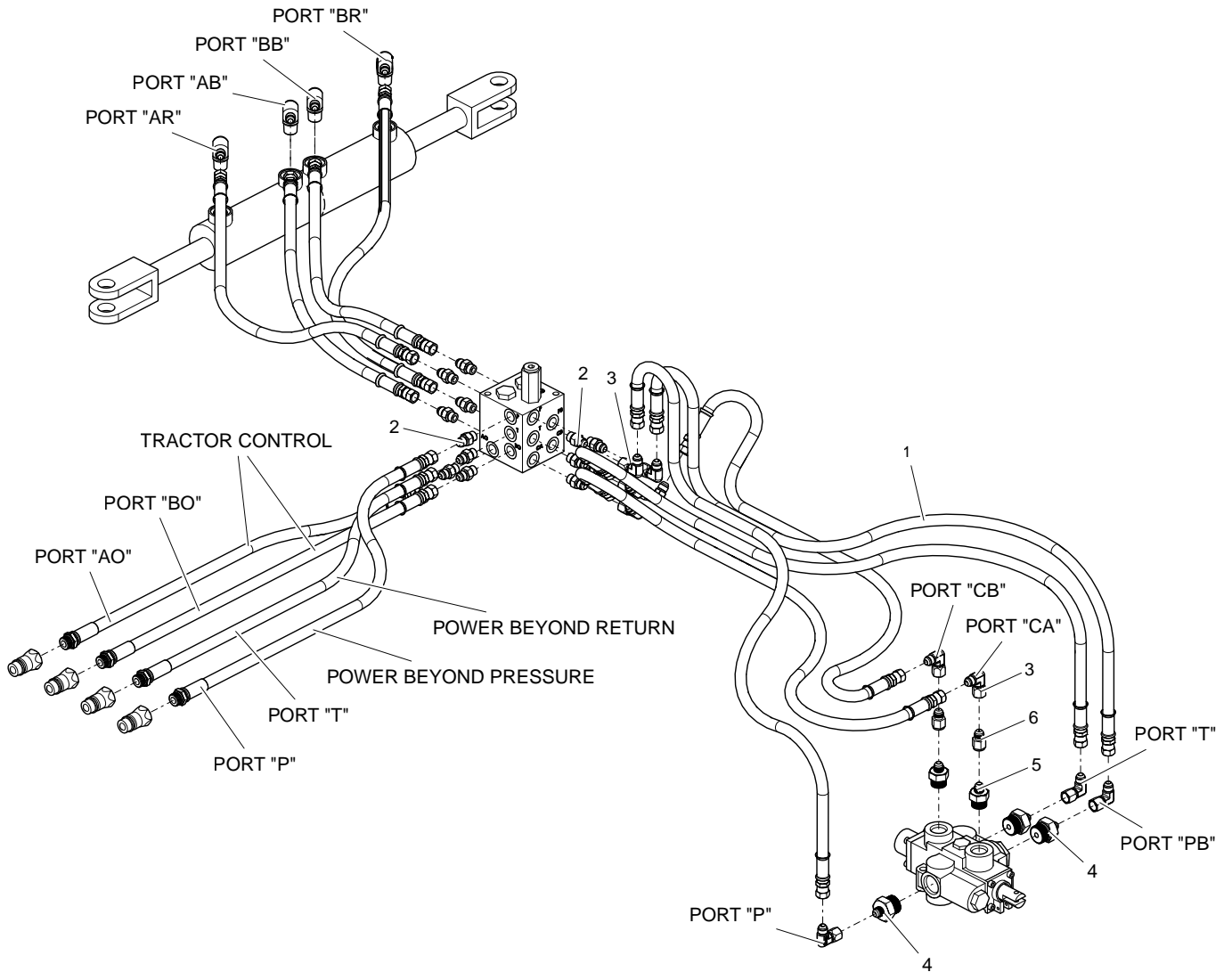

ITEM NO.	PART NUMBER	DESCRIPTION	QTY.
1	905-19155	HOSE, 3/8 x 120.0", 6FJX x 6FJX	5
2	905-03120	ADAPTER, STRAIGHT, 6MJ x 6MB	6
3	905-03163	ADAPTER, 90° ELBOW, 6MJ x 6FJX	10
4	905-03210	ADAPTER, STRAIGHT, 6MJ x 12MB	3
5	905-03198	ADAPTER, STRAIGHT, 6MJ x 10MB	2
6	905-03220	ADAPTER, 1/16 RESTRICTOR, 6FJ x 6MJ	1
-	500-1-0393	ROW FINDER HOSE KIT	-

SCALPER HYDRAULIC COMPONENTS

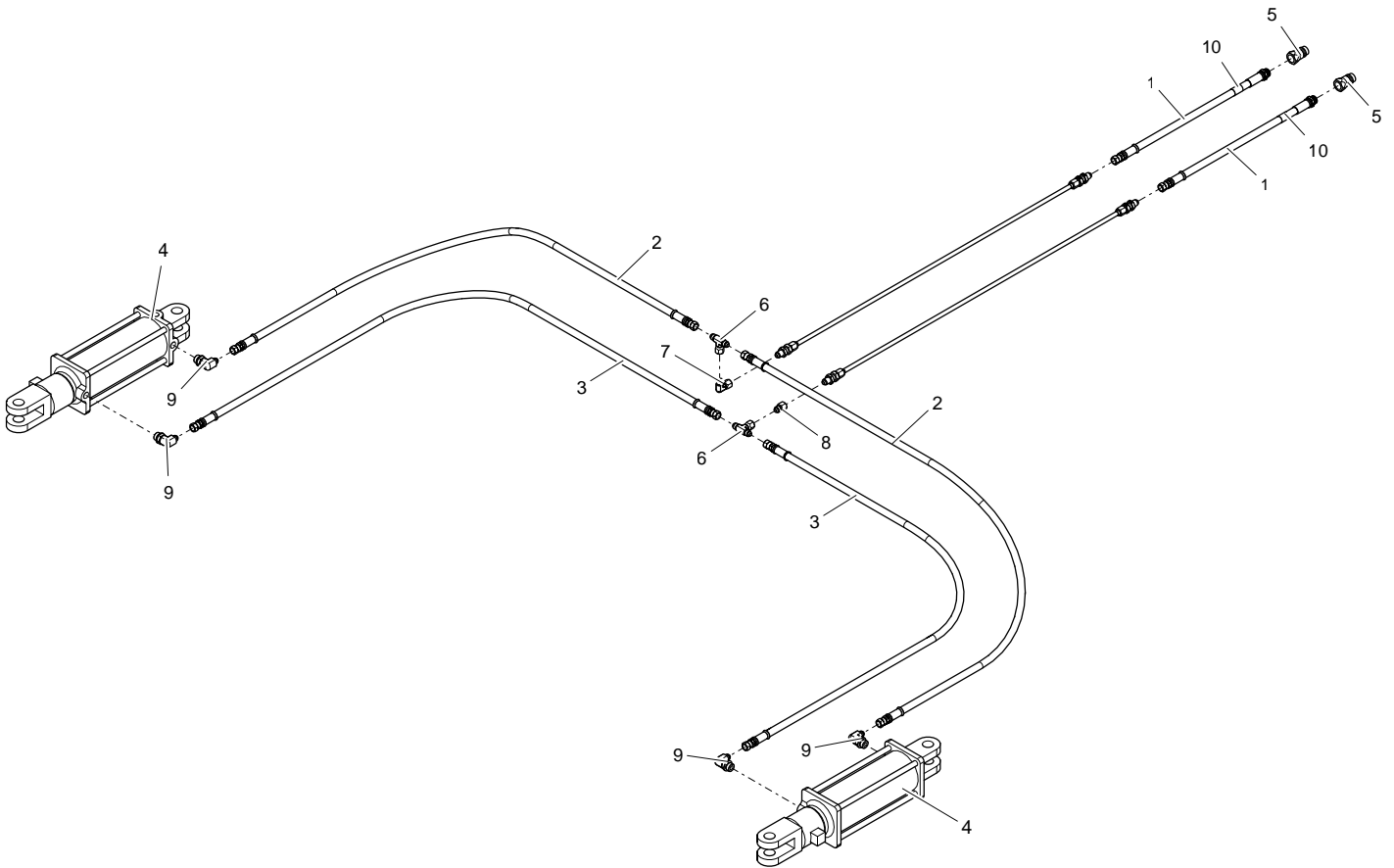

ITEM NO.	PART NUMBER	DESCRIPTION	QTY.
1	905-19154	HOSE, 3/8 x 115.0, 8MB x 6FJX (<i>SHORT HITCH</i>)	2
	905-19139	HOSE, 3/8 x 150.0, 8MB x 6FJX (<i>LONG HITCH</i>)	
2	905-19117	HOSE, 3/8 x 57.0, 6FJX x 6FJX	2
	905-19226	HOSE, 3/8 x 96.0, 6FJX x 6FJX	
3	905-19170	HOSE, 3/8 x 64.0, 6FJX x 6FJX	2
	905-19182	HOSE, 3/8 x 114.0, 6FJX x 6FJX	
4	905-21400	CYLINDER, 3-1/2 x 8	2
5	905-19126	QUICK COUPLER	2
6	905-03127	ADAPTER, TEE, 6MJ x 6MJ x 6FJX	2
7	905-03163	ADAPTER, 90° ELBOW, 6MJ x 6FJX	1
8	905-03277	ADAPTER, STRAIGHT, 6FJ x 6MJ	1
9	905-03114	ADAPTER, 90° ELBOW, 6MJ x 8MB	4
10	500-3-2841	VIOLET HOSE LABEL	
-	500-1-0427	HOSE KIT, RIGID SCALPERS 1222 <i>*DOES NOT INCLUDE CYLINDER*</i>	-
-	500-1-0428	HOSE KIT, RIGID SCALPERS 630 - 922 <i>*DOES NOT INCLUDE CYLINDER*</i>	-
-	500-1-0429	HOSE KIT, RIGID SCALPERS 430 - 622 <i>*DOES NOT INCLUDE CYLINDER*</i>	-

DOOR OPENER HYDRAULIC COMPONENTS

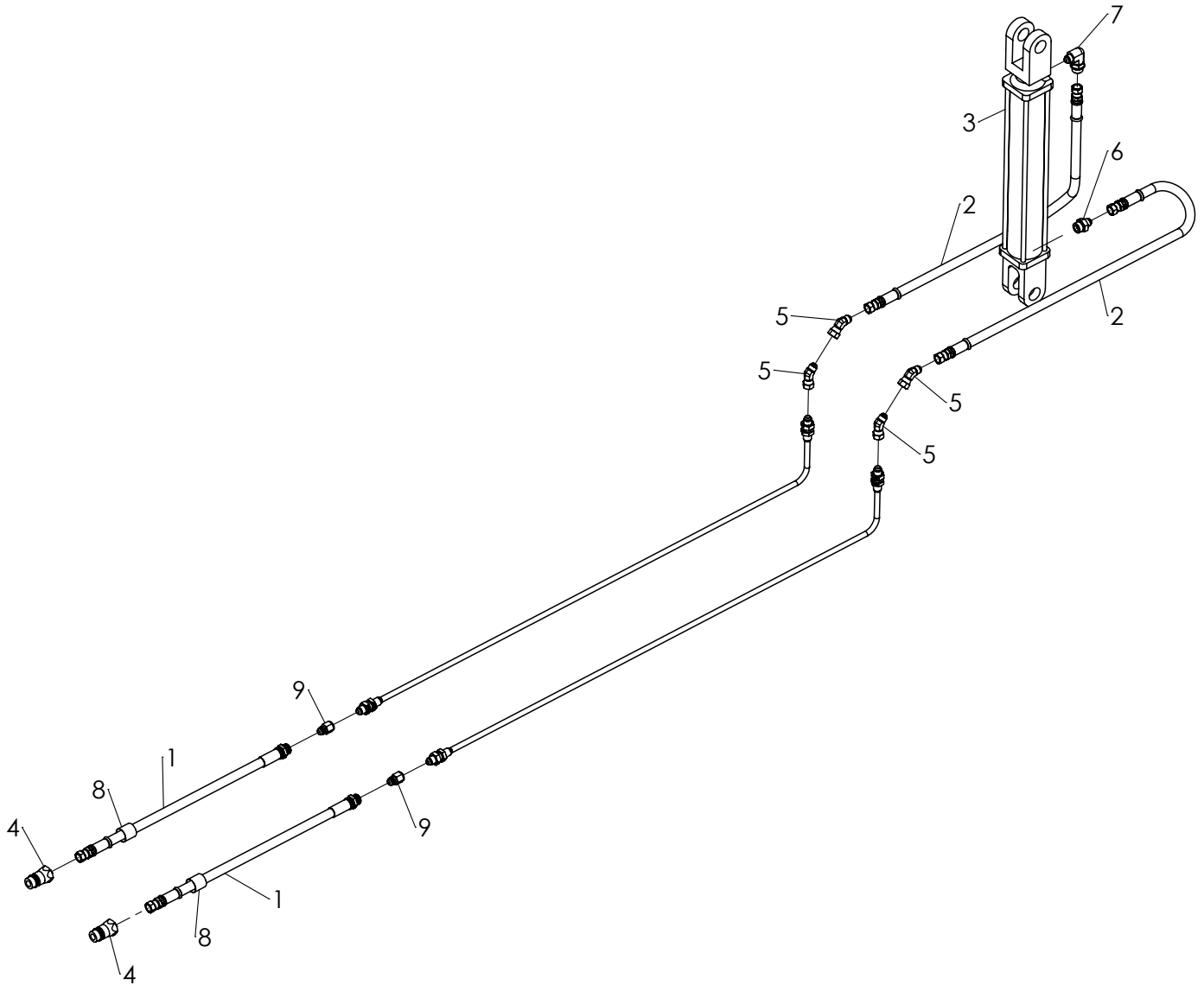

ITEM NO.	PART NUMBER	DESCRIPTION	QTY.
1	905-19154	HOSE, 3/8 x 115.0, 8MB x 6FJX (<i>SHORT HITCH</i>)	2
	905-19139	HOSE, 3/8 x 150.0, 8MB x 6FJX (<i>LONG HITCH</i>)	2
2	905-19124	HOSE, 3/8 x 25.0, 6FJX x 6FJX	2
3	905-21453	CYLINDER, 2 x 12	1
4	905-19126	QUICK COUPLER	2
5	905-03282	ADAPTER, 45° ELBOW, 6MJ x 6FJX	4
6	905-03115	ADAPTER, STRAIGHT, 6MJ x 8MB	1
7	905-03114	ADAPTER, 90° ELBOW, 6MJ x 8MB	1
8	500-3-2840	BLUE HOSE LABEL	2
9	905-03261	RESTRICTOR, 6FJ X 6MJ X 1/32 HOLE	2
-	500-1-0431	HOSE KIT, DOOR OPENER (<i>DOES NOT INCLUDE CYLINDER</i>)	-

RIGID STRUT PLUMBING COMPONENTS

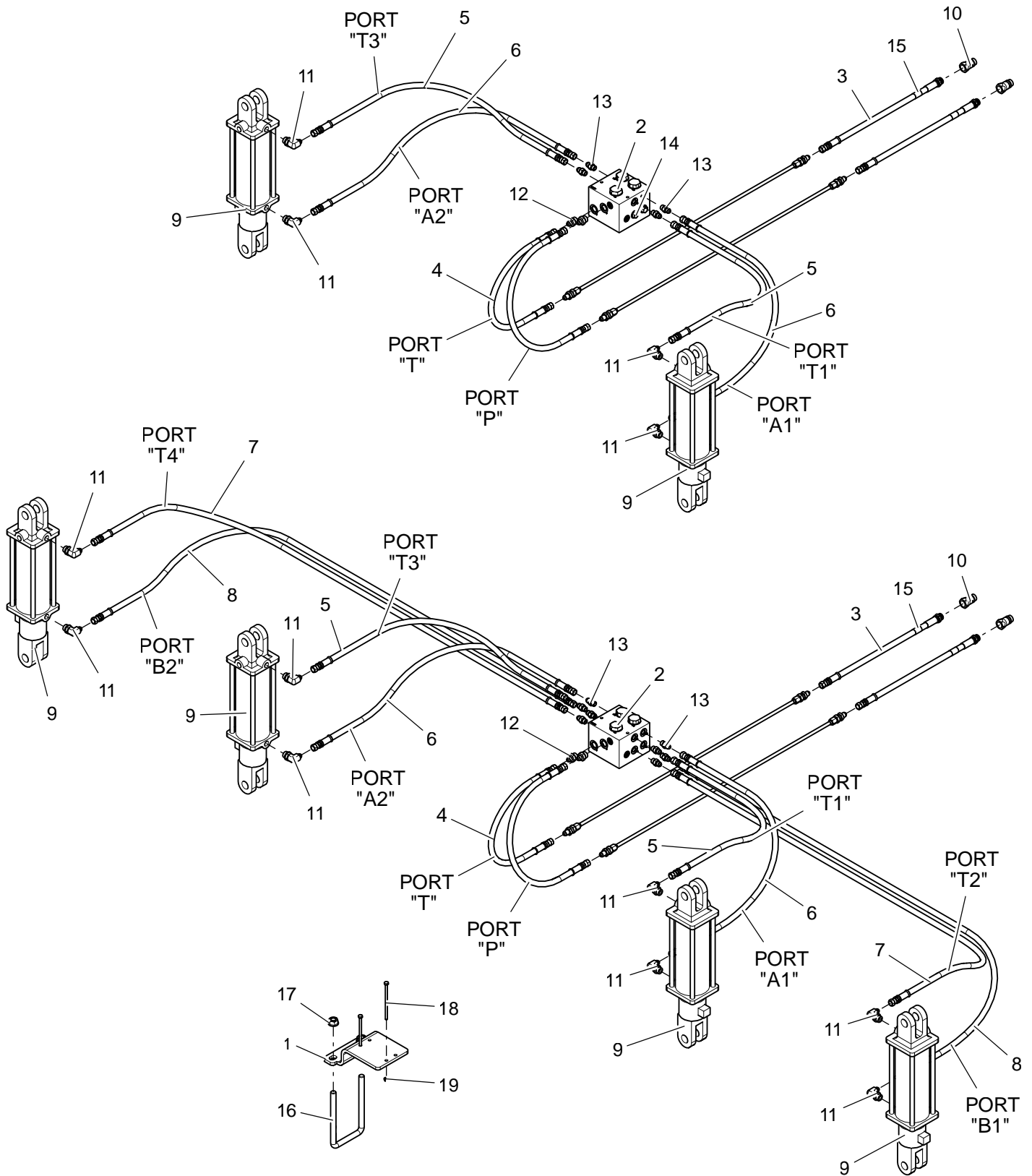

RIGID STRUT PLUMBING COMPONENTS

ITEM NO.	PART NUMBER	DESCRIPTION	QTY.
1	500-3-2895	FLOW DIVIDER MOUNT	1
2	905-03274	FLOW DIVIDER	1
3	905-19154	HOSE, 3/8 x 115.0, 8MB x 6FJX (<i>SHORT HITCH</i>)	2
	905-19139	HOSE, 3/8 x 150.0, 8MB x 6FJX (<i>LONG HITCH</i>)	
4	905-19124	HOSE, 3/8 x 25.0, 6FJX x 6FJX	2
5	905-19169	HOSE, 3/8 x 54.0, 6FJX x 6FJX (<i>66" STRUT SPACING</i>)	2
	905-19255	HOSE, 3/8 x 76.0, 6FJX x 6FJX (<i>88" - 110" STRUT SPACING</i>)	
	905-19193	HOSE, 3/8 x 106.0, 6FJX x 6FJX (<i>132" - 154" STRUT SPACING</i>)	
6	905-19125	HOSE, 3/8 x 62.0, 6FJX x 6FJX (<i>66" STRUT SPACING</i>)	2
	905-19152	HOSE, 3/8 x 84.0, 6FJX x 6FJX (<i>88" - 110" STRUT SPACING</i>)	
	905-19182	HOSE, 3/8 x 114.0, 6FJX x 6FJX (<i>132" - 154" STRUT SPACING</i>)	
7	905-19175	HOSE, 3/8 x 144.0, 6FJX x 6FJX (<i>198" STRUT SPACING</i>)	0 / 2
8	905-19175	HOSE, 3/8 x 144.0, 6FJX x 6FJX (<i>198" STRUT SPACING</i>)	0 / 2
9	905-21400	CYLINDER, 3-1/2 x 8	2 / 4
10	905-19126	QUICK COUPLER	2
11	905-03114	ADAPTER, 90° ELBOW, 6MJ x 8MB	4 / 8
12	905-03115	ADAPTER, STRAIGHT, 6MJ x 8MB	2
13	905-03120	ADAPTER, STRAIGHT, 6MJ x 6MB	4 / 8
14	905-03265	ADAPTER, PLUG, 6MB	4 / 0
15	500-3-2839	GREEN HOSE LABEL	2
16	200-3-0017	U-BOLT, 5/8 NC x 4 x 7-1/4	1
17	900-06145	NUT, SPIRALOCK, 5/8 NC	2
18	900-01037	BOLT, 1/4 NC x 5	2
19	900-06135	NUT, SPIRALOCK, 1/4 NC	2
-	500-1-0424	HOSE KIT, RIGID STRUTS (<i>66" STRUT SPACING</i>) *	-
-	500-1-0425	HOSE KIT, RIGID STRUTS (<i>88" - 110" STRUT SPACING</i>) *	-
-	500-1-0426	HOSE KIT, RIGID STRUTS (<i>132" - 154" STRUT SPACING</i>) *	-
-	500-1-0422	HOSE KIT, RIGID STRUTS (<i>4 PAIR SMALL TIRE STRUTS</i>) *	-

* HOSE KITS DO NOT INCLUDE CYLINDERS

STEERABLE STRUT PLUMBING COMPONENTS

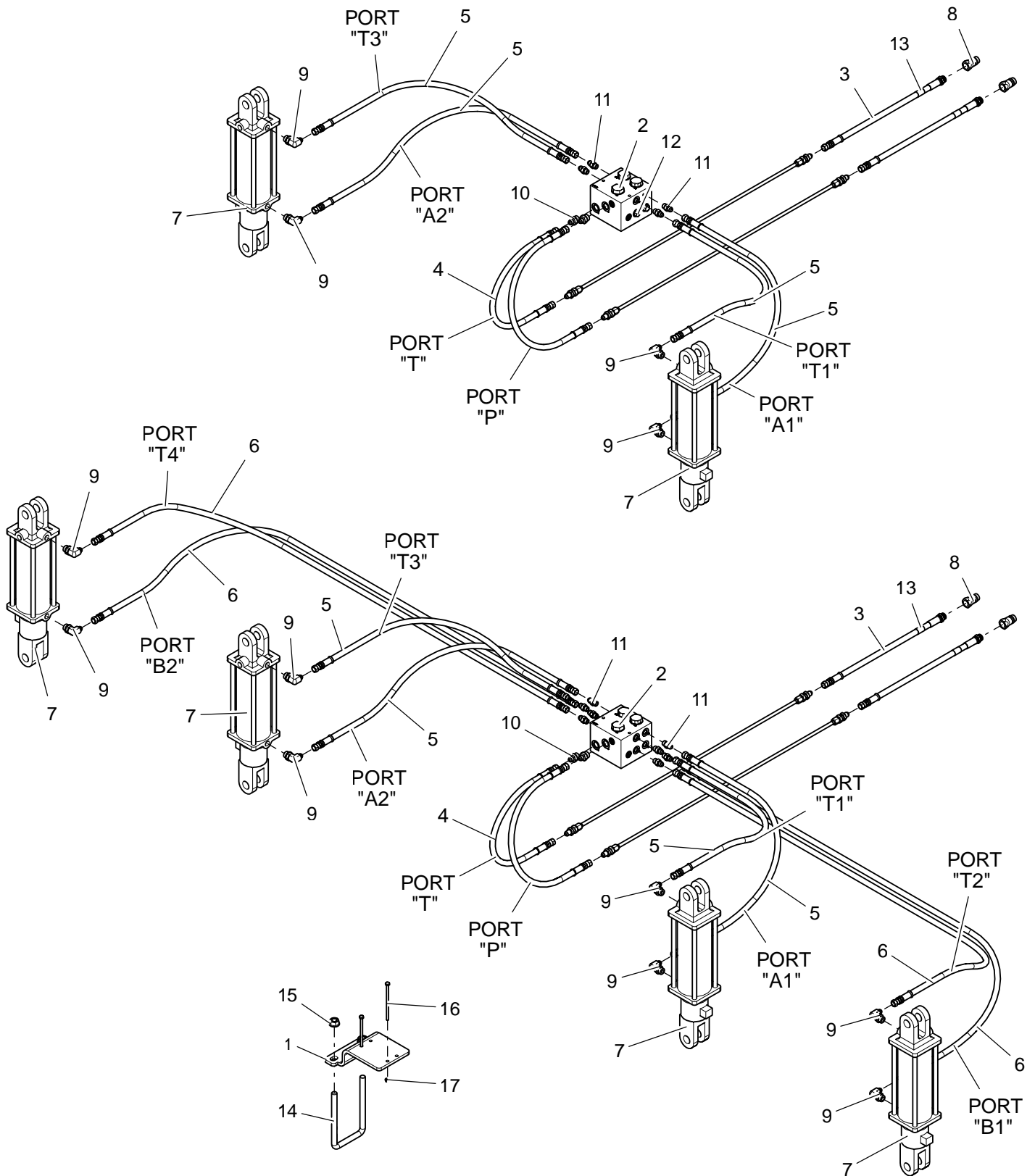

STEERABLE STRUT PLUMBING COMPONENTS

ITEM NO.	PART NUMBER	DESCRIPTION	QTY.
1	500-3-2895	FLOW DIVIDER MOUNT	1
2	905-03274	FLOW DIVIDER	1
3	905-19154	HOSE, 3/8 x 115.0, 8MB x 6FJX (<i>SHORT HITCH</i>)	2
3	905-19139	HOSE, 3/8 x 150.0, 8MB x 6FJX (<i>LONG HITCH</i>)	2
4	905-19124	HOSE, 3/8 x 25.0, 6FJX x 6FJX	2
5	905-19196	HOSE, 3/8 x 72.0, 6FJX x 6FJX (<i>66" STRUT SPACING</i>)	4
5	905-19226	HOSE, 3/8 x 96.0, 6FJX x 6FJX (<i>88" - 110" STRUT SPACING</i>)	4
5	905-19155	HOSE, 3/8 x 120.0, 6FJX x 6FJX (<i>132" - 154" STRUT SPACING</i>)	4
6	905-19175	HOSE, 3/8 x 144.0, 6FJX x 6FJX (<i>198" STRUT SPACING</i>)	0 / 4
7	905-21400	CYLINDER, 3-1/2 x 8	2 / 4
8	905-19126	QUICK COUPLER	2
9	905-03114	ADAPTER, 90° ELBOW, 6MJ x 8MB	4 / 8
10	905-03115	ADAPTER, STRAIGHT, 6MJ x 8MB	2
11	905-03120	ADAPTER, STRAIGHT, 6MJ x 6MB	4 / 8
12	905-03265	ADAPTER, PLUG, 6MB	4 / 0
13	500-3-2839	GREEN HOSE LABEL	2
14	200-3-0017	U-BOLT, 5/8 NC x 4 x 7-1/4	1
15	900-06145	NUT, SPIRALOCK, 5/8 NC	2
16	900-01037	BOLT, 1/4 NC x 5	2
17	900-06135	NUT, SPIRALOCK, 1/4 NC	2
-	500-1-0419	HOSE KIT, STEERABLE STRUTS (<i>66" STRUT SPACING</i>) *	-
-	500-1-0420	HOSE KIT, STEERABLE STRUTS (<i>88" - 110" STRUT SPACING</i>) *	-
-	500-1-0421	HOSE KIT, STEERABLE STRUTS (<i>132" - 154" STRUT SPACING</i>) *	-
-	500-1-0422	HOSE KIT, STEERABLE STRUTS (<i>4 PAIR SMALL TIRE STRUTS</i>) *	-

* HOSE KITS DO NOT INCLUDE CYLINDERS

HARDLINE COMPONENTS

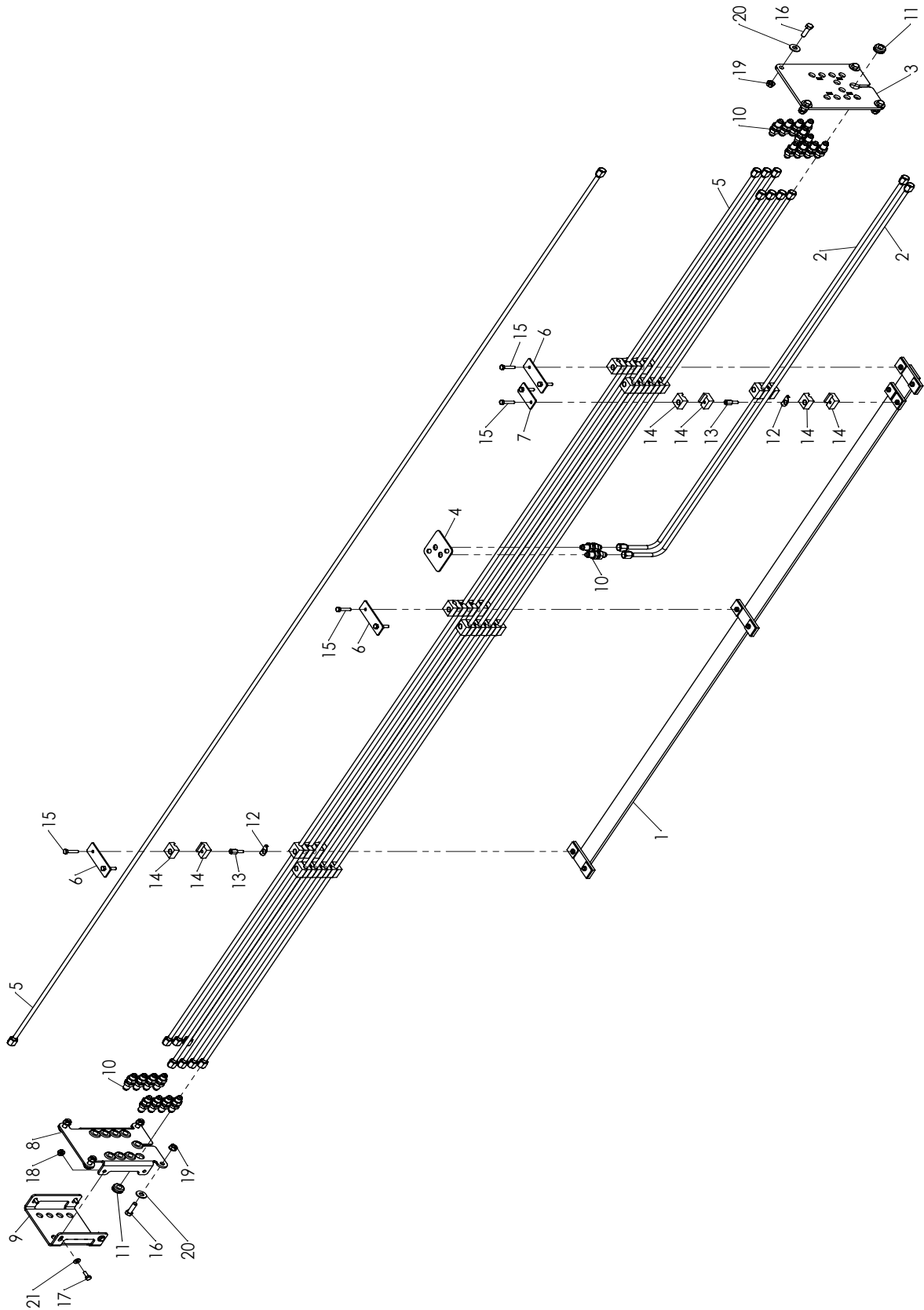

HARDLINE COMPONENTS

ITEM NO.	PART NUMBER	DESCRIPTION	QTY.
1	500-2-1463	HARDLINE MOUNT WELD	1
2	500-2-1451	RIGID CENTER HARDLINE	2
3	500-2-1464	FRONT HARDLINE COVER PLATE WELD	1
4	500-3-3007	CENTER HYDRAULIC HOLDER CAP	1
5	500-2-1449	RIGID STRAIGHT HARDLINE	8
6	500-3-3009	WIDE CLAMP BLOCK TOP PLATE	3
7	500-3-3010	CENTER CLAMP BLOCK TOP PLATE	1
8	500-3-3005	BACK INSIDE PLATE - HARDLINE COVER	1
9	500-3-3006	BACK OUTSIDE PLATE - HARDLINE COVER	1
10	905-03280	ADAPTER, BULKHEAD, 6MJ X 6MJBH	20
11	904-01313	RUBBER GROMMET	10
12	900-31090	SINGLE BORE SAFETY LOCK PLATE	20
13	900-31091	SINGLE BORE CLAMP STACKING BOLT	20
14	900-31087	SINGLE BORE CLAMP BLOCK	56
15	900-01011	BOLT, 1/4 NC X 1-1/4	8
16	900-01111	BOLT, 3/8 NC X 1-1/4	8
17	900-01005	BOLT, 1/4 NC X 3/4	4
18	900-06136	NUT, FLANGE SPIRALOCK 1/4 NC	4
19	900-06139	NUT, SPIRALOCK 3/8 NC	8
20	900-11033	WASHER, 3/8	8
21	900-11031	WASHER, 1/4	4

LONG HITCH PTO DRIVE SHAFT COMPONENTS

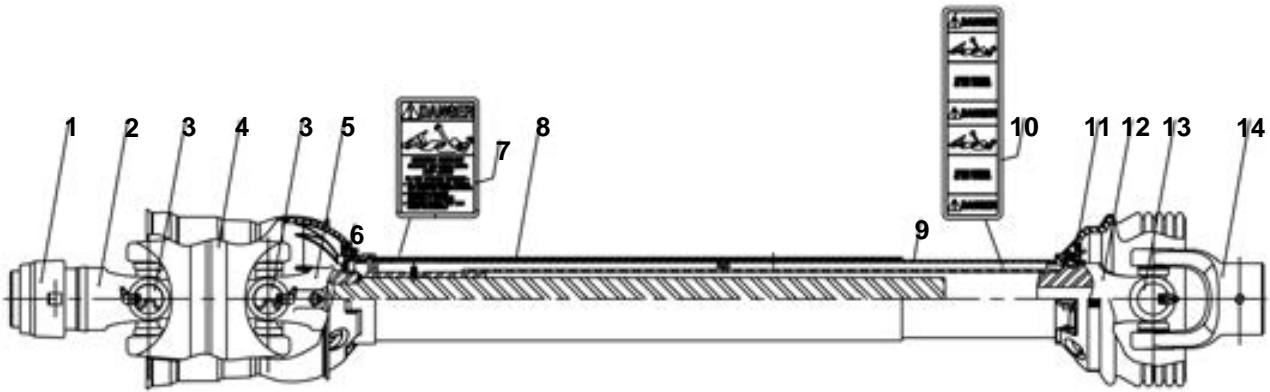

ITEM NO.	PART NUMBER	DESCRIPTION	QTY.
1	903-18240	SSL / AUTO-LOK REPAIR KIT, 1-3/8"	1
	903-18255	SSL / AUTO-LOK REPAIR KIT, 1-3/4"	
2	903-18241	WWCV AUTO-LOK YOKE, 1-3/8"	1
	903-18256	WWCV AUTO-LOK YOKE, 1-3/4"	
3	903-17712	CAT 5 80 E CV CROSS & BEARING KIT	1
4	903-18242	CV CENTER HOUSING	1
5	903-18243	YOKE & SHAFT (1.69-20 SPLINE), 1-3/8"	1
	903-18257	YOKE & SHAFT (1.69-20 SPLINE), 1-3/4"	
6	903-18244	GUARD REPAIR KIT	1
7	903-17455	SAFETY SIGN	2
8	903-18258	OUTER GUARD	1
9	903-18259	INNER GUARD	1
10	903-18247	SAFETY SIGN	
11	903-18248	GUARD REPAIR KIT	1
12	903-18260	YOKE, TUBE, & SLIP SLEEVE	1
13	903-18250	44E CROSS & BEARING KIT	1
14	903-17639	YOKE	1
-	903-18216	LONG HITCH PTO DRIVE SHAFT, COMPLETE 1-3/8"	-
-	903-18217	LONG HITCH PTO DRIVE SHAFT, COMPLETE 1-3/4"	-

LONG HITCH DRIVELINE COMPONENTS

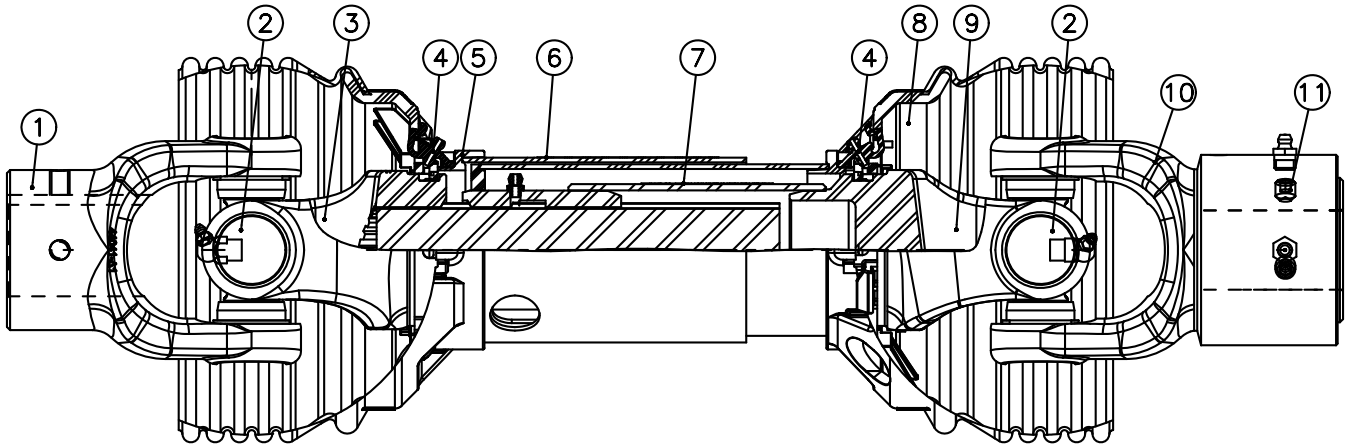

ITEM NO.	PART NUMBER	DESCRIPTION	QTY.
1	903-17639	YOKE	1
2	903-18250	44E CROSS KIT	2
3	903-18430	YOKE & SHAFT (1.69-20 SPLINE)	1
4	903-18248	GUARD REPAIR KIT	2
5	903-18431	OUTER GUARD	1
6	903-17455	SAFETY SIGN	1
7	903-18247	SAFETY SIGN	1
8	903-18432	INNER GUARD	1
9	903-18433	YOKE, TUBE & SLIP SLEEVE	1
10	903-17721	OVERRUNNING CLUTCH ASSY	1
11	903-18434	SETSCREW, 3/8 NC x 3/8	2
-	903-18423	COMPLETE LONG HITCH DRIVE SHAFT, COMPLETE	-

PTO DRIVE SHAFT COMPONENTS

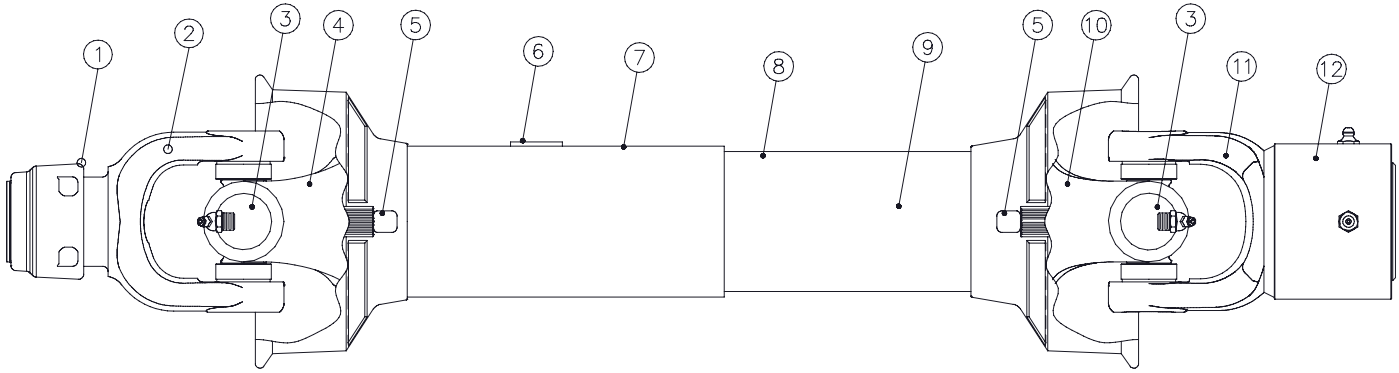

ITEM NO.	PART NUMBER	DESCRIPTION	QTY.
1	903-18106	SAFETY SLIDE LOCK REPAIR KIT, 1-3/8"	1
	903-17772	SAFETY SLIDE LOCK REPAIR KIT, 1-3/4"	
2	903-18116	SAFETY SLIDE LOCK YOKE, 1-3/8"	1
	903-18108	SAFETY SLIDE LOCK YOKE, 1-3/4"	
3	903-17525	44R CROSS & BEARING KIT	1
4	903-18109	YOKE & SHAFT (1.69-20 SPLINE)	1
5	903-17774	NYLON REPAIR KIT	2
6	903-17455	SAFETY SIGN	1
7	903-18110	OUTER GUARD	1
8	903-11111	INNER GUARD	1
9	903-17456	SAFETY SIGN	1
10	903-18112	YOKE, TUBE, & SLIP SLEEVE	1
11	903-17721	OVERRUNNING CLUTCH	1
12	903-18210	OVERRUNNING CLUTCH REPAIR KIT	1
	903-18088	COMPLETE PTO DRIVE SHAFT, COMPLETE 1-3/8"	
	903-18089	COMPLETE PTO DRIVE SHAFT, COMPLETE 1-3/4"	

PTO DRIVE SHAFT COMPONENTS (CONSTANT VELOCITY)

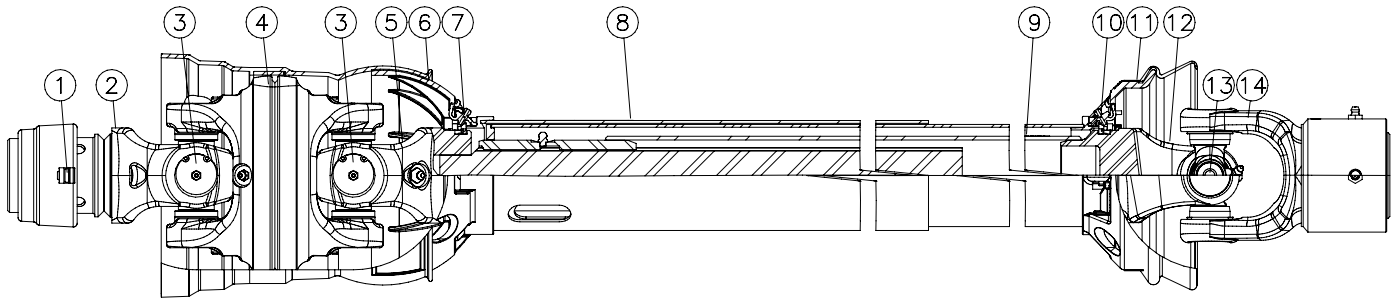

ITEM NO.	PART NUMBER	DESCRIPTION	QTY.
1	903-17427	SSL / AUTO-LOK REPAIR KIT, 1-3/8"	1
	903-17772	SSL / AUTO-LOK REPAIR KIT, 1-3/4"	
2	903-18334	WWCV AUTO-LOK YOKE, 1-3/8"	1
	903-18327	WWCV AUTO-LOK YOKE, 1-3/4"	
3	903-18328	AB8/AW24/CAT 6 80° PBL CROSS KIT	1
4	903-18329	WWCV CENTER HOUSING	1
5	903-18405	WWCV YOKE & SHAFT (1.69-20 SPLINE)	1
6	-	OUTER GUARD	1
7	903-18395	GUARD REPAIR KIT	2
8	903-17455	SAFETY SIGN	1
9	903-17456	SAFETY SIGN	1
10	903-18248	GUARD REPAIR KIT	
11	-	INNER GUARD	1
12	903-17718	YOKE, TUBE, & SLIP SLEEVE	1
13	903-17525	44E CROSS & BEARING KIT	1
14	903-17721	OVERRUNNING CLUTCH	1
	903-17717	GUARD SET * INCLUDES #6, #10 *	
	903-18406	COMPLETE PTO DRIVE SHAFT, COMPLETE 1-3/8"	
	903-18407	COMPLETE PTO DRIVE SHAFT, COMPLETE 1-3/4"	

GEAR BOX COMPONENTS

NOTES:

- 1. GEAR RATIO IS 1.5:1 REDUCER FROM THE CROSS SHAFT
- 2 TORQUE 3/8-16 CAPSCREWS (ITEM 15) TO 35-40 FT-LBS
- 3 STAMP PART NO. AND LOT NO. IN AREA SHOWN

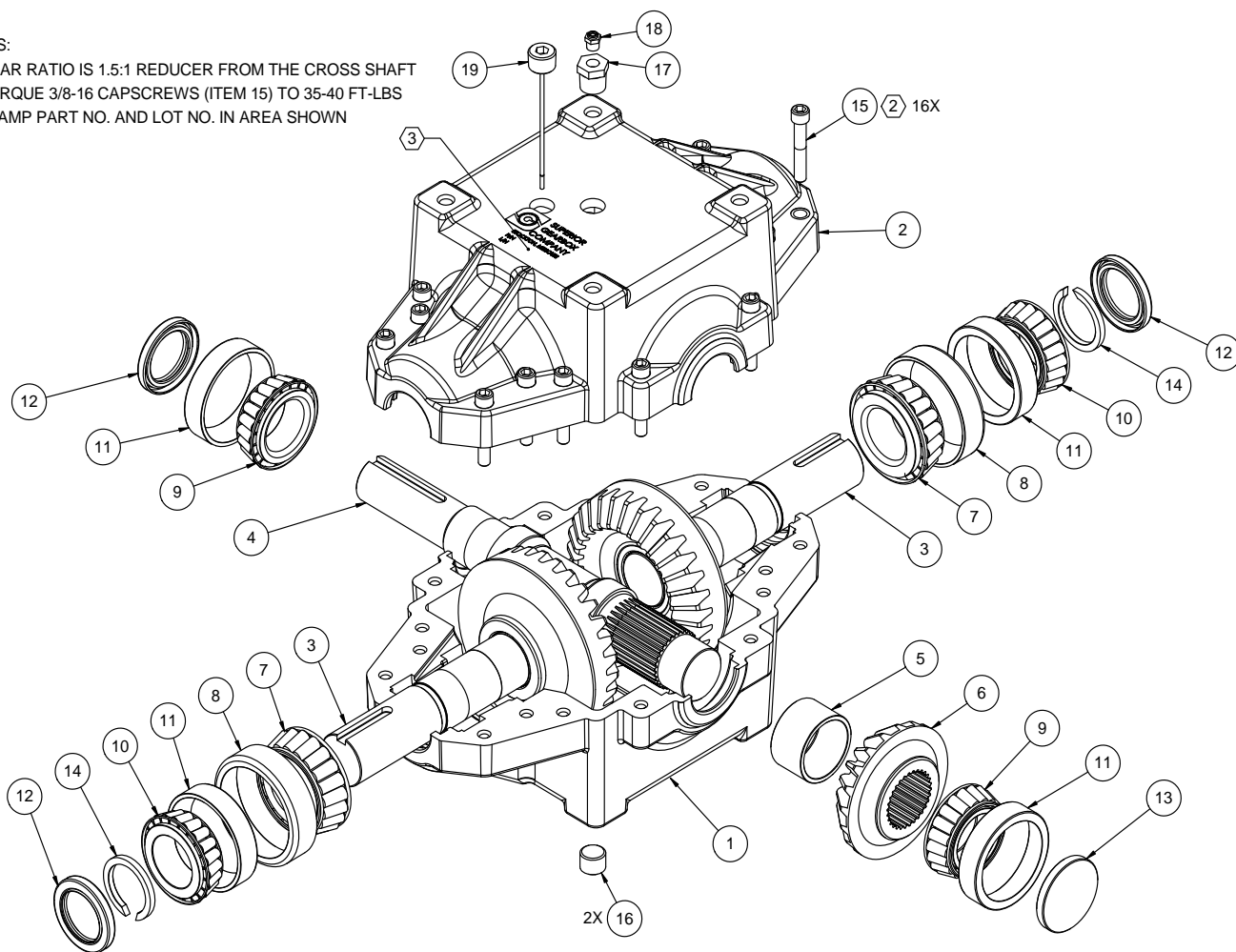

ITEM NO.	PART NUMBER	DESCRIPTION	QTY.
1	903-15291	CASTING, MACHINE BOTTOM THREADED	1
2	903-15292	CASTING, MACHINE TOP HALF	1
3	903-15591	SUBA, R600 STUB SHAFT/GEAR	2
4	903-15592	SHAFT, CROSS R600 1.5i SPLINED	1
5	903-15593	SPACER, 2.25 X 1.939, 1.324	1
6	903-15595	GEAR, R600 1.50:1 SPLINE 20 TOOTH	1
7	901-01151	BEARING CONE 3782	2
8	901-01153	BEARING CUP 3720	2
9	901-01328	BEARING CONE 25580	2
10	901-01150	BEARING CONE 25581	2
11	901-01152	BEARING CUP 25520	4
12	901-09125	SEAL, TC-1.750-2.437-.312	3
13	903-15594	SEAL, END CAP, 2.45-.312	1
14	900-39030	RETAINING RING, 1.750	2
15	900-03033	BOLT, 3/8-16 X 2.25 SHCS	16
16	905-03078	PLUG, 1/2-14 NPT SCHD W/3M	2
17	905-01159	BUSHING, 1/2 NPT TO 1/8 NPT	1
18	905-03080	PLUG, VENT 5 PSI	1
19	903-15411	DIP STICK, STANDARD	1
-	903-15399	GEAR BOX, COMPLETE	1

LIGHT KIT COMPONENTS

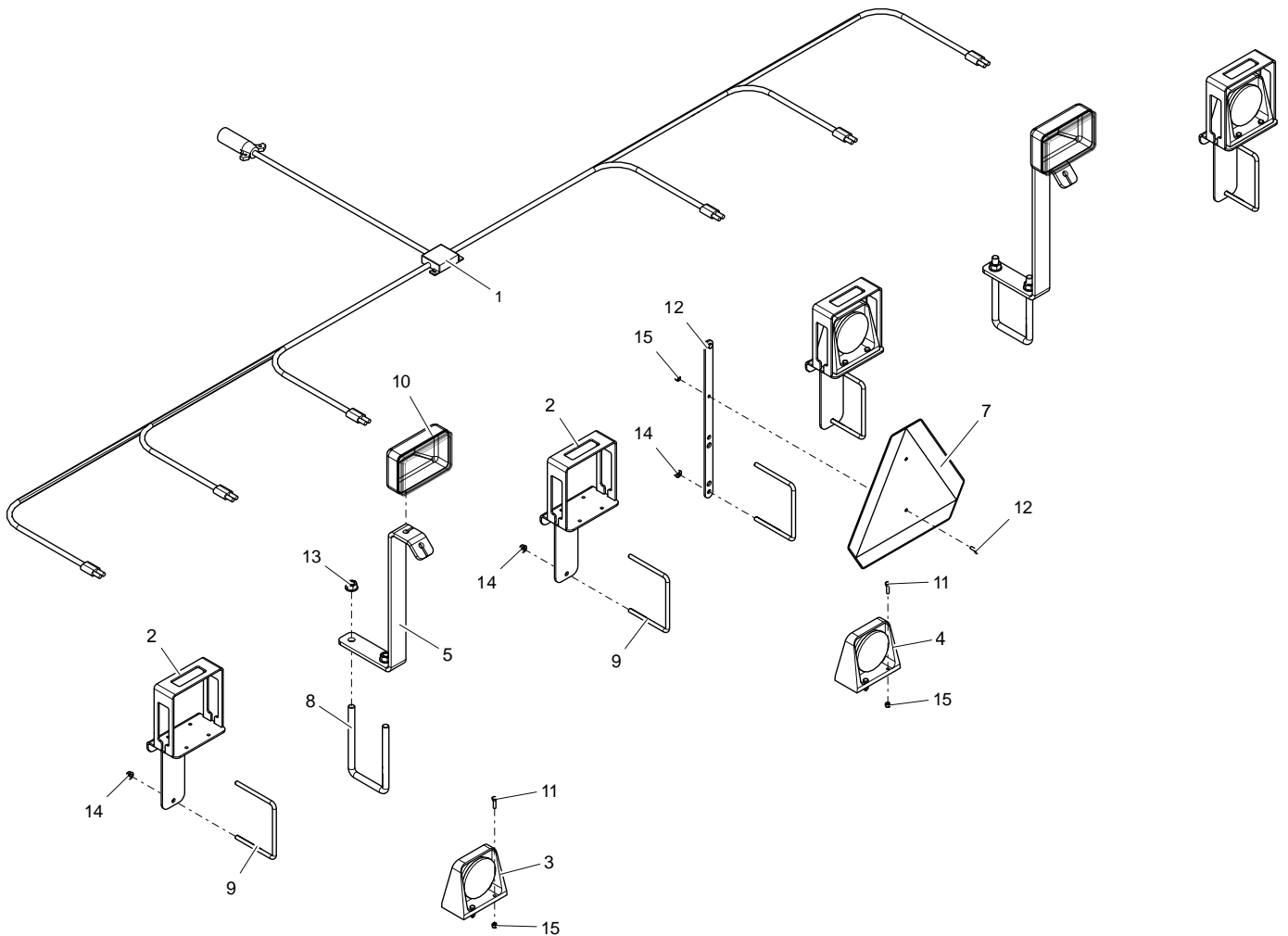

ITEM NO.	PART NUMBER	DESCRIPTION	QTY.
1	500-3-2201	WIRE HARNESS, 830 - 1222	1
	500-3-2168	WIRE HARNESS, 460 - 822	
2	500-2-1245	LIGHT MOUNT BRACKET	4
3	904-01154	LAMP, AMBER	2
4	904-01155	LAMP, RED	2
5	500-3-1720	LIGHT FIELD BRACKET	2
6	500-3-2091	SMV MOUNT	1
7	500-3-1696	SMV SIGN	1
8	200-3-0017	U-BOLT, 5/8 NC x 4 x 7-1/4	2
9	900-35000	U-BOLT, 3/8 NC x 6 x 5	5
10	500-3-1721	FIELD LIGHT	2
11	900-01009	BOLT, 1/4 NC x 1	16
12	900-01005	BOLT, 1/4 NC x 3/4	2
13	900-06145	NUT, SPIRALOCK 5/8 NC	4
14	900-06139	NUT, SPIRALOCK 3/8 NC	8
15	900-06496	NUT, TOP LOCK 1/4 NC	18
-	500-1-0184	LIGHT KIT, 830 - 1222	-
-	500-1-0185	LIGHT KIT, 430 - 822	-

HITCH COMPONENTS

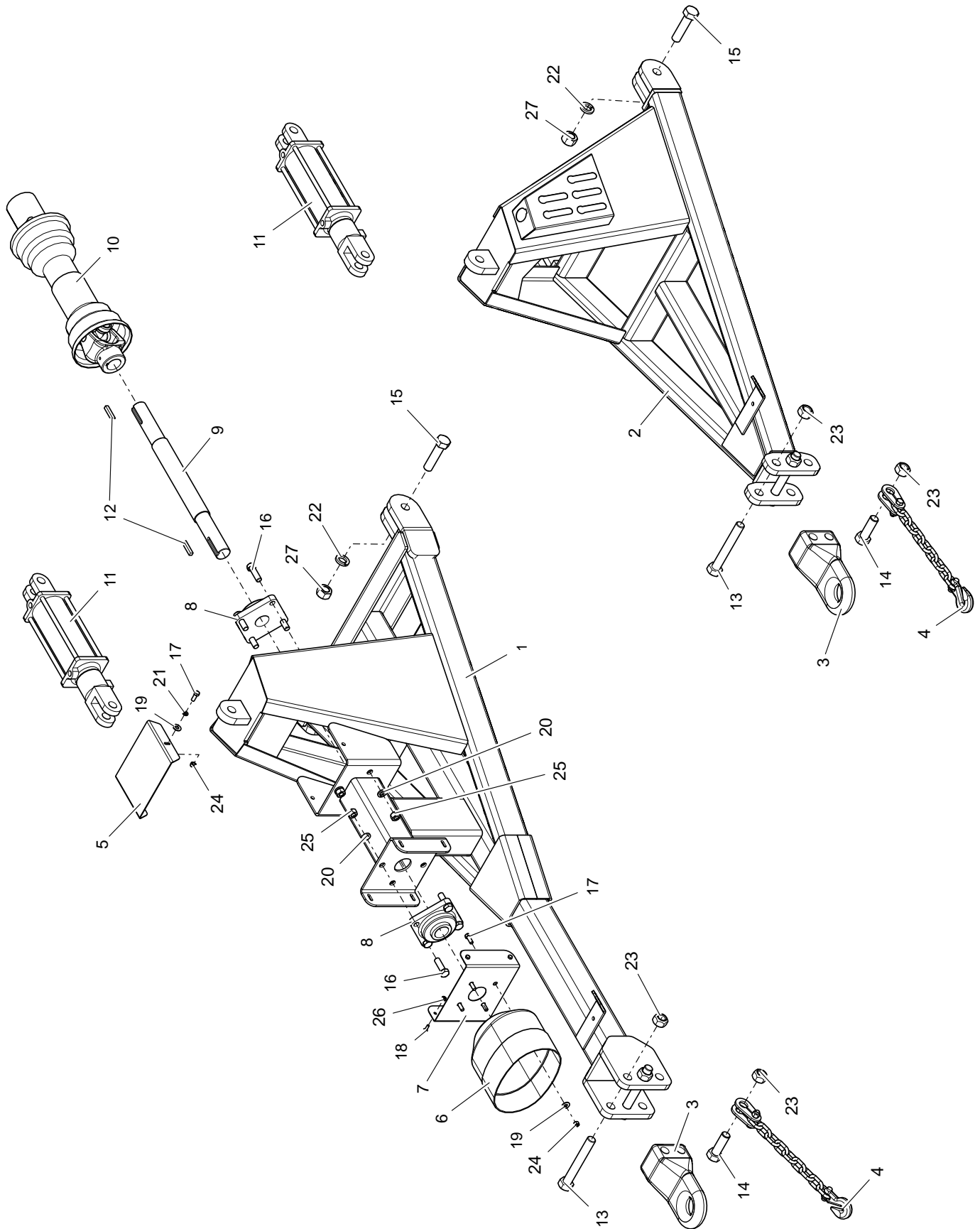

HITCH COMPONENTS

ITEM NO.	PART NUMBER	DESCRIPTION	QTY.
1	500-2-1325	LONG HITCH FRAME	1
2	500-2-1352	SHORT HITCH FRAME	1
3	505-3-0831	HITCH, CAT-3	2
4	905-07123	SAFETY CHAIN	2
5	500-3-2710	TOP PTO SHIELD	1
6	903-18007	PTO BELL	1
7	500-3-2164	GUARD BRACKET	1
8	901-01185	BEARING, 4-BOLT 1-3/4	2
9	700-3-2357	PTO TRANSFER SHAFT	1
10	903-18423	JUMPER DRIVELINE	1
11	905-21400	CYLINDER, 3-1/2 x 8	2
12	100-3-3333	KEY, 3/8 x 3/8 x 2	2
13	900-02930	BOLT, 1 NC x 7	4
14	900-01519	BOLT, 1 NC x 3	2
15	900-01527	BOLT, 1 NC x 4	4
16	900-01345	BOLT, 5/8 NC x 2	8
17	900-01109	BOLT, 3/8 NC x 1	6
18	900-01005	BOLT, 1/4 NC x 3/4	4
19	900-11033	WASHER, 3/8	6
20	900-11015	WASHER, LOCK 5/8	8
21	900-11011	WASHER, LOCK 3/8	2
22	900-11021	WASHER, LOCK 1	4
23	900-06514	NUT, TOP LOCK 1 NC	6
24	900-06005	NUT, 3/8 NC	6
25	900-06013	NUT, 5/8 NC	8
26	900-06135	NUT, SPIRALOCK 1/4 NC	4
27	900-06019	NUT, 1 NC	4
28	500-2-0792	SHORT HITCH HOSE KIT	-
29	500-2-1243	LONG HITCH HOSE KIT	-
30	500-2-1426	LONG HITCH ELECTRICAL EXTENSION KIT	-
-	500-1-0403	SHORT HITCH, COMPLETE KIT	-
-	500-2-1326	LONG HITCH, COMPLETE KIT	-

HITCH HYDRAULIC COMPONENTS

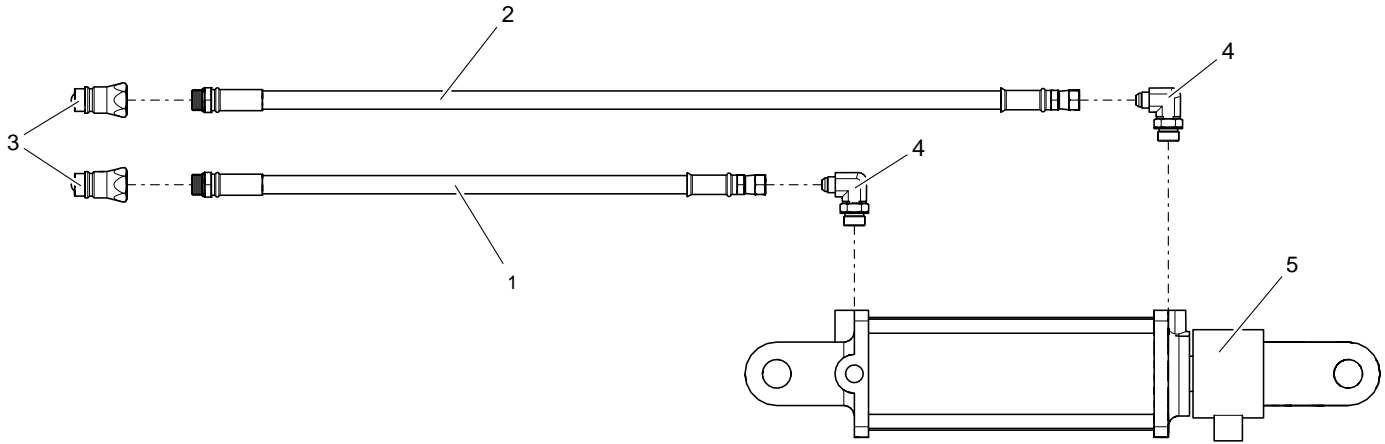



ITEM NO.	PART NUMBER	DESCRIPTION	QTY.
1	905-19176	HOSE, 3/8 x 105.0, 8MB x 6FJX (<i>SHORT HITCH</i>)	1
	905-19279	HOSE, 3/8 x 140.0, 8MB x 6FJX (<i>LONG HITCH</i>)	
2	905-19154	HOSE, 3/8 x 115.0, 8MB x 6FJX (<i>SHORT HITCH</i>)	1
	905-19139	HOSE, 3/8 x 150.0, 8MB x 6FJX (<i>LONG HITCH</i>)	
3	905-19126	QUICK COUPLER	2
4	905-03114	ADAPTER, 90° ELBOW, 6MJ x 8MB	2
5	905-21400	CYLINDER, 3-1/2 x 8	1
-	500-2-0792	HOSE KIT, SHORT HITCH	-
-	500-2-1242	HOSE KIT, LONG HITCH	-
-	500-2-0789	HYDRAULIC KIT, SHORT HITCH (<i>INCLUDES CYLINDER</i>)	-
-	500-2-1243	HYDRAULIC KIT, LONG HITCH (<i>INCLUDES CYLINDER</i>)	-

BOLT TORQUE CHART

SAE Series Torque Chart

Always tighten hardware to these values unless a different torque value or tightening procedure is listed for a specific application. Fasteners must always be replaced with the same grade as specified in the manual parts list.

Make sure fastener threads are clean and you properly start thread engagement.

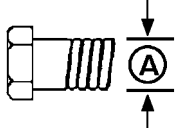
SAE Bolt Head Identification		 SAE Grade 2 (No Dashes)		 SAE Grade 5 (3 Radial Dashes)		 SAE Grade 8 (6 Radial Dashes)	
A Diameter (Inches)	Wrench Size	MARKING ON HEAD					
		SAE 2		SAE 5		SAE 8	
		ft./lb.	(Nm)	ft./lb.	(Nm)	ft./lb.	(Nm)
1/4"	7/16"	6	(8)	10	(13)	14	(18)
5/16"	1/2"	12	(17)	19	(26)	27	(37)
3/8"	9/16"	23	(31)	35	(47)	49	(67)
7/16"	5/8"	36	(48)	55	(75)	78	(106)
1/2"	3/4"	55	(75)	85	(115)	120	(163)
9/16"	13/16"	78	(106)	121	(164)	171	(232)
5/8"	15/16"	110	(149)	170	(230)	240	(325)
3/4"	1-1/8"	192	(261)	297	(403)	420	(569)
7/8"	1-5/16"	306	(416)	474	(642)	669	(907)
1"	1-1/2"	350	(475)	680	(925)	1020	(1383)
1-1/8"	1-11/16"	450	(610)	885	(1200)		
1-1/4"	1-7/8"	600	(815)	1255	(1700)		
1-3/8"	2-1/16"	675	(915)	1620	(2200)		
1-1/2"	2-1/4"	920	(1250)	2200	(2900)		

Metric Series Torque Chart

Use only metric tools on metric hardware. Always tighten hardware to these values unless a different torque value or tightening procedure is listed for a specific application. Fasteners must always be replaced with the same grade.

Make sure fastener threads are clean and you properly start thread engagement.

A Diameter & Thread Pitch (Millimeters)	Wrench Size	COARSE THREAD				FINE THREAD				A Diameter & Thread Pitch (Millimeters)	Metric Bolt Head Identification
		MARKING ON HEAD									
		Metric 8.8		Metric 10.9		Metric 8.8		Metric 10.9			
		Nm	ft./lb.	Nm	ft./lb.	Nm	ft./lb.	Nm	ft./lb.		
6x1.0	10 mm	8	6	11	8	8	6	11	8	6x1.0	
8x1.25	13 mm	20	15	27	20	21	16	29	22	8x1.0	
10x1.5	16 mm	39	29	54	40	41	30	57	42	10x1.25	
12x1.75	18 mm	68	50	94	70	75	55	103	76	12x1.25	
14x2.0	21 mm	109	80	151	111	118	87	163	120	14x1.5	
16x2.0	24 mm	169	125	234	173	181	133	250	184	16x1.5	
18x2.5	27 mm	234	172	323	239	263	194	363	268	18x1.5	
20 x 2.5	30 mm	330	244	457	337	367	270	507	374	20x1.5	
22 x 2.5	34 mm	451	332	623	460	495	365	684	505	22 x 1.5	
24 x 3.0	36 mm	571	421	790	583	623	459	861	635	24 x 2.0	
30 x 3.0	46 mm	1175	867	1626	1199	1258	928	1740	1283	30 x 2.0	

Typical Washer Installations

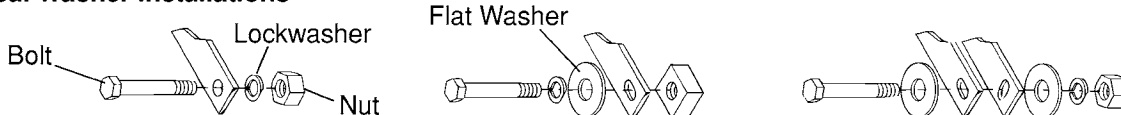

8/9/00

ABBREVIATIONS

AG	Agriculture	NC	National Course
ASAE	American Society of Agricultural Engineers	NF.....	National Fine
ATF.....	Automatic Transmission Fluid	NPSM.....	National Pipe Straight Mechanical
BSPP.....	British Standard Pipe Parallel	NPT	National Pipe Tapered
BSPTM.....	British Standard Pipe Tapered Male	NPT SWF.....	National Pipe Tapered Swivel Female
CV	Constant Velocity	Nm.....	Newton Meter
CCW	Counter-Clockwise	OSHA...	Occupational Safety and Health Administration
CW	Clockwise	P	Pitch
DIA.....	Diameter	PBY	Power Beyond
EP.....	Extreme Pressure	psi.....	Pounds per Square Inch
F	Female	PTO.....	Power Take Off
FB.....	Female O-Ring Boss	QD.....	Quick Disconnect
FJ	Female Boss	RH	Right Hand
FJX.....	Female Swivel JIC	ROPS.....	Roll Over Protection Structure
FP.....	Female Pipe	RPM	Revolutions Per Minute
ft./lb.....	Foot Pound	RT.....	Right
GA	Gauge	SAE	Society of Automotive Engineers
GR (5, etc.)	Grade (5, etc.)	SMV	Slow Moving Vehicle
HHCS.....	Hex Head Cap Screw	UNC	Unified Coarse
HT.....	Heat Treated	UNF.....	Unified Fine
in.....	Inch	UNS.....	Unified Special
JIC.....	Joint Industry Council 37° Flare	ZP	Zinc Plate
kg.....	Kilogram		
km/h	Kilometers Per Hour		
lb.....	Pound		
LH.....	Left Hand		
LT.....	Left		
in.....	Inches		
m	Meter		
mm	Millimeter		
M	Male		
MB.....	Male O-Ring Boss		
MJ.....	Male JIC		
MJX.....	Male Swivel JIC		
MP	Male Pipe		
MPa.....	Mega Pascal		
MPH	Miles Per Hour		
N.....	Newton		

INDEX

ADDITIONAL EQUIPMENT	25	PARTS INDEX	41
Rear Steer	25	SAFETY	
Scalpers	27	Check Lists	7
Stabilizer Struts	28	Hazard Area	24
Steel Flail Units.....	28	Operator Sign-Off Record.....	9
GENERAL		Safety & Instructional Decals.....	8 - 9
Abbreviations.....	112	Safety-Alert Symbols	Inside Front Cover
Bolt Torque Chart	111	Safety Rules	2
General Information	1	SERVICE & MAINTENANCE	31
Introduction.....	Inside Front Cover	Bearing Lock Collars.....	37
Product Warranty	Inside Back Cover	Belt Replacement.....	38
Replacement Part Warranty	114	Belt Tension	37
Table of Contents	1	Changing Gearbox Oil	33
FIELD OPERATION	21	Flail Replacement	36
Flail Patterns.....	23	Flail Spacing.....	35
Operating the Defoliator.....	24	Flail Tube Hanger Bearing.....	38
Preparing for Operation	22	Greasing	31
Speed vs. Weight Ratio	22	Lubricants	31
Transporting the Unit.....	22	Lubrication Schedule	32
Turning.....	24	10hrs.....	32
OPERATION	11	25hrs.....	32
Attaching the Defoliator to the Tractor.....	15	40hrs.....	33
Breaking-In	13	Annually.....	33
Choosing the Correct Equipment	14	Lubrication Service Record.....	34
Complete Attachment.....	16	Scalpers.....	39
Machine Settings.....	17	Wheel Spacing	35
Flail Height.....	18	STORAGE	29
Flail Spacing.....	18	TROUBLE SHOOTING	40
Machine Leveling	17		
Stabilizer Wheel Position	19		
Wheel Spacing	19		
Pre-Operation Check List	13		
Principal Components.....	12		
Removing the Defoliator from Tractor	16		
Scalper Settings (Optional).....	20		

WARRANTY

Please Enter Information Below and Save For Future Reference.

Date Purchased: _____ From (Dealer): _____

Model Number: _____ Serial Number: _____

ALLOWAY STANDARD, d/b/a ALLOWAY, warrants this product to be free from defect in material and workmanship for TWELVE (12) MONTHS COMMENCING ON THE DATE OF DELIVERY OF THE PRODUCT TO THE ORIGINAL PURCHASER.

Under no circumstances will this Warranty apply in the event that the product, in the good faith opinion of ALLOWAY, has been subjected to improper operation, improper maintenance, misuse, or an accident. This Warranty does not apply in the event that the product has been materially modified or repaired by someone other than ALLOWAY, a ALLOWAY authorized dealer or distributor, and/or a ALLOWAY authorized service center; This Warranty does not cover normal wear or tear, or normal maintenance items. This Warranty also does not cover repairs made with parts other than those obtainable through ALLOWAY.

This Warranty is extended solely to the original purchaser of the product. Should the original purchaser sell or otherwise transfer this product to a third party, this Warranty does not transfer to the third party purchaser in any way. There are no third party beneficiaries of this Warranty.

ALLOWAY makes no warranty, express or implied, with respect to tires or other parts or accessories not manufactured by ALLOWAY. Their respective manufacturers, if any, provide warranties for these items, separately. ALLOWAY'S' obligation under this Warranty is limited to, at ALLOWAYS' option, the repair or replacement, free of charge, of the product if ALLOWAY, in its sole discretion, deems it to be defective or in noncompliance with this Warranty. The product must be returned to ALLOWAY with proof of purchase within thirty (30) days after such defect or noncompliance is discovered or should have been discovered, routed through the dealer and distributor from whom the purchase was made, transportation charges prepaid. ALLOWAY shall complete such repair or replacement within a reasonable time after ALLOWAY receives the product. THERE ARE NO OTHER REMEDIES UNDER THIS WARRANTY. THE REMEDY OF REPAIR OR REPLACEMENT IS THE SOLE AND EXCLUSIVE REMEDY UNDER THIS WARRANTY.

THERE ARE NO WARRANTIES, WHICH EXTEND BEYOND THE DESCRIPTION ON THE FACE OF THIS WARRANTY. ALLOWAY MAKES NO OTHER WARRANTY, EXPRESS OR IMPLIED, AND ALLOWAY SPECIFICALLY DISCLAIMS ANY IMPLIED WARRANTY OF MERCHANTABILITY AND/OR ANY IMPLIED WARRANTY OF FITNESS FOR A PARTICULAR PURPOSE.

ALLOWAY shall not be liable for any incidental or consequential losses, damages or expenses, arising directly or indirectly from the product, whether such claim is based upon breach of contract, breach of warranty, negligence, strict liability in tort or any other legal theory. Without limiting the generality of the foregoing. Alloway specifically disclaims any damages relating to (i) lost profits, business, revenues or goodwill; (ii) loss of crops; (iii) loss because of delay in harvesting; (iv) any expense or loss Incurred for labor, supplies, substitute machinery or rental; or (v) any other type of damage to property or economic loss.

This Warranty is subject to any existing conditions of supply, which may directly affect ALLOWAYS' ability to obtain materials or manufacture replacement parts.

No agent, representative, dealer, distributor, serviceperson, salesperson, or employee of any company; including without limitation, ALLOWAY, its authorized dealers, distributors, and service centers, is authorized to alter, modify, or enlarge this Warranty.

This Warranty is effective only if the warranty registration card is returned within ten (10) days.

Answers to any questions regarding warranty service and locations may be obtained by contacting:

Alloway
4230 14th Ave.NW
Fargo, North Dakota 58102
701-356-4983



WARRANTY

ALLOWAY STANDARD, d/b/a ALLOWAY, warrants this product to be free from defect in material and workmanship for a period of One (1) year, ninety (90) days for Service Parts, from the date of delivery of the product to the original purchaser.

Under no circumstances will this Warranty apply in the event that the product, in the good faith opinion of ALLOWAY, has been subjected to improper operation, improper maintenance, misuse, or an accident. This Warranty does not cover normal wear or tear, or normal maintenance items.

This Warranty is extended solely to the original purchaser of the product. Should the original purchaser sell or otherwise transfer this product to a third party, this Warranty does not transfer to the third party purchaser in any way. There are no third party beneficiaries of this Warranty.

ALLOWAY'S' obligation under this Warranty is limited to, at ALLOWAY'S option, the repair or replacement, free of charge, of the product if ALLOWAY, in its sole discretion, deems it, to be defective or in noncompliance with this Warranty. The product must be returned to ALLOWAY with proof of purchase within thirty (30) days after such defect or noncompliance is discovered or should have been discovered, routed through the dealer and distributor from whom the purchase was made, transportation charges prepaid. ALLOWAY shall complete such repair or replacement within a reasonable time after ALLOWAY receives the product. THERE ARE NO OTHER REMEDIES UNDER THIS WARRANTY. THE REMEDY OF REPAIR OR REPLACEMENT IS THE SOLE AND EXCLUSIVE REMEDY UNDER THIS WARRANTY.

THERE ARE NO WARRANTIES WHICH EXTEND BEYOND THE DESCRIPTION ON THE FACE OF THIS WARRANTY. ALLOWAY MAKES NO OTHER WARRANTY, EXPRESS OR IMPLIED, AND ALLOWAY SPECIFICALLY DISCLAIMS ANY IMPLIED WARRANTY OF MERCHANTABILITY AND/OR ANY IMPLIED WARRANTY OF FITNESS FOR A PARTICULAR PURPOSE.

ALLOWAY shall not be liable for any incidental or consequential losses, damages or expenses, arising directly or indirectly from the product, whether such claim is based upon breach of contract, breach, of warranty, negligence, strict liability in tort or any other legal theory. Without limiting the generality of the foregoing, Alloway specifically disclaims any damages relating to (i) lost profits, business, revenues or goodwill; (ii) loss of crops; (iii) loss because of delay in harvesting; (iv) any expense or loss incurred for labor, supplies, substitute machinery or rental; or (v) any other type of damage to property or economic loss.

This Warranty is subject to any existing conditions of supply, which may directly affect ALLOWAYS' ability to obtain materials or manufacture replacement parts.

No agent, representative, dealer, distributor, service person, salesperson, or employee of any company, including without limitation, ALLOWAY, Its authorized dealers, distributors, and service centers, IS authorized to alter, modify, or enlarge this Warranty.

Answers to any questions regarding warranty service and locations may be obtained by contacting:

Alloway
4230 14th Ave.NW
Fargo, North Dakota 58102
701-356-4983



PART NUMBER
500-5-0012



Quality • Innovation

Alloway Standard Industries
4230 14th Avenue NW
Fargo, North Dakota 58102

Local/Intl: 1-701-356-4983
Toll Free: 1-877-275-8714
Fax: 1-701-356-4985