

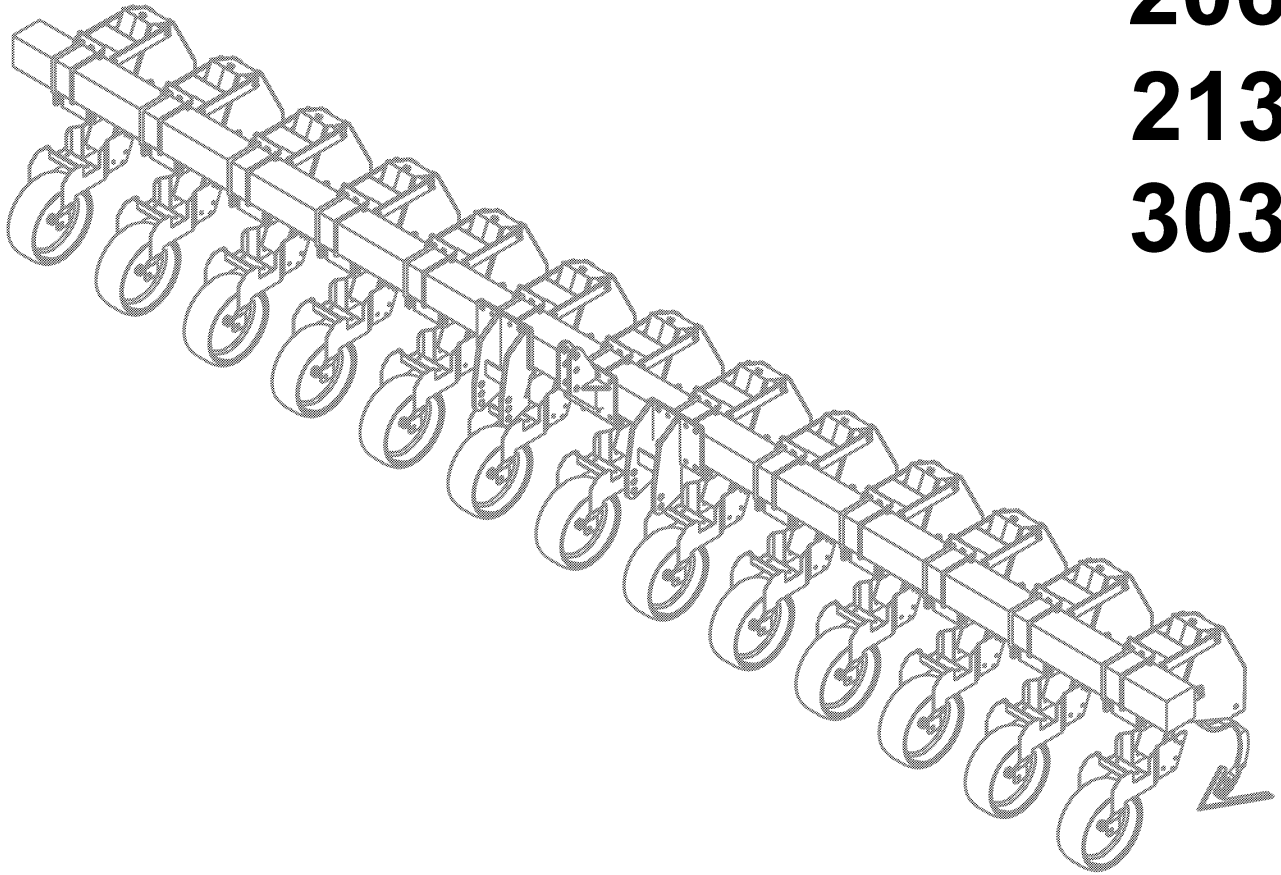

**ROW CROP
CULTIVATOR
MODELS 2040
2065
2130
3030**



OPERATOR'S MANUAL



TO THE DEALER:

Assembly and proper installation of this product is the responsibility of the Alloway dealer. Read manual instructions and safety rules. Make sure all items on the Dealer's Pre-Delivery and Delivery Check Lists in the Operator's Manual are completed before releasing equipment to the owner.

The dealer must complete the Warranty Registration included in this manual. Both dealer and customer must sign the registration which certifies that all Dealer Check List items have been completed. The dealer is to return the prepaid postage portion to Alloway, give one copy to the customer, and retain one copy. **Note: Warranty credit is subject to this form being completed and returned.**

TO THE OWNER:

Read this manual before operating your Alloway equipment. The information presented will prepare you to do a better and safer job. Keep this manual handy for ready reference. Require all operators to read this manual carefully and become acquainted with all the adjustment and operating procedures before attempting to operate. Replacement manuals can be obtained from your dealer or, in the United States and Canada, by calling 1-877-275-8714.

The equipment you have purchased has been carefully engineered and manufactured to provide dependable and satisfactory use. Like all mechanical products, it will require cleaning and upkeep. Lubricate the unit as specified. Observe all safety information in this manual and safety decals on the equipment.

For service, your authorized Alloway dealer has trained mechanics, genuine Alloway service parts, and the necessary tools and equipment to handle all your needs.

Use only genuine Alloway service parts. Substitute parts will void the warranty and may not meet standards required for safe and satisfactory operation. Record the model number and serial number of your equipment in the spaces provided:

Model: _____ **Date of Purchase:** _____

Serial Number: (see Safety Decal section for location) _____

Provide this information to your dealer to obtain correct repair parts.

Throughout this manual, the term **IMPORTANT** is used to indicate that failure to observe can cause damage to equipment. The terms **CAUTION**, **WARNING** and **DANGER** are used in conjunction with the Safety-Alert Symbol, (a triangle with an exclamation mark), to indicate the degree of hazard for items of personal safety.



This Safety-Alert Symbol indicates a hazard and means **ATTENTION! BECOME ALERT! YOUR SAFETY IS INVOLVED!**



Indicates an imminently hazardous situation that, if not avoided, will result in death or serious injury.



Indicates a potentially hazardous situation that, if not avoided, could result in death or serious injury, and includes hazards that are exposed when guards are removed.



Indicates a potentially hazardous situation that, if not avoided, may result in minor or moderate injury.

IMPORTANT

Indicates that failure to observe can cause damage to equipment.

NOTE

Indicates helpful information.

TABLE OF CONTENTS

INTRODUCTION	Inside Front Cover
SPECIFICATIONS	1 - 3
GENERAL INFORMATION	4
ABBREVIATIONS	4
SAFETY RULES	5 - 7
SAFETY DECALS	8
BOLT SIZE CHART	10
BOLT TORQUE CHART	11
OPERATION	12
SERVICE	23
ASSEMBLY	26
INDEX TO PARTS LISTS	65
INDEX	121
WARRANTIES	Inside Back Cover

SPECIFICATIONS

The Alloway Cultivator has several toolbar types and a variety of optional equipment for row crop applications. Optional equipment may change these specifications. Cultivator weights do not include optional equipment.

3 Point Hitches

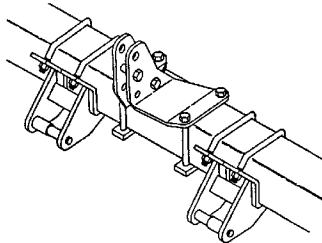

C. 4 piece hitch for 7" x 7" beams. Recommended on 8 row and smaller units.

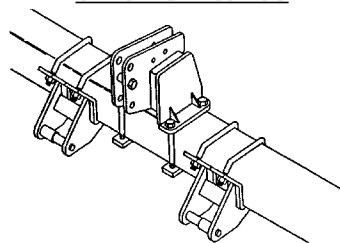

D. 3 piece heavy duty hitch for 7" x 7" beams. Recommended on 12 row and larger units.

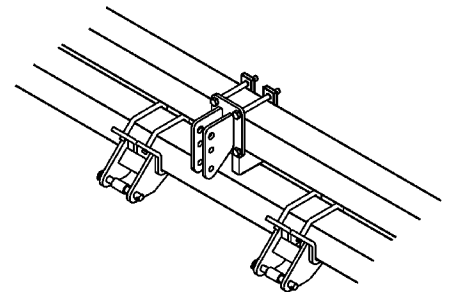

E. 3 piece heavy duty hitch for top reinforced 7" x 7" beams. Recommended on all TRF tool bars.

Tool Bar Codes

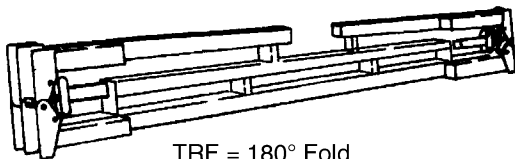

TRF = 180° Fold
Reinforced Hinges

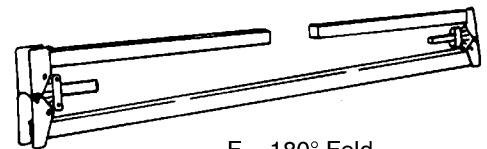

F = 180° Fold

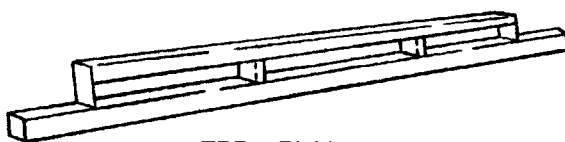

TRR = Rigid



FR = 180° Fold Reinforced
Double Bar

NOTE: All tool bars are made of 7" x 7" x 1/4" square tubing.

(Specifications continued on next page)

SPECIFICATIONS (Continued)

**MODEL 2040
ADJUSTABLE**

Size	Toolbar	3 Pt. Hitch	# of Tines	Trans. Width	Weight
4 Row 36-40"		C	21	200"	1530#
6 Row 22-24"		C	19	152"	1695#
6 Row 30"		C	31	200"	1955#
6 Row 36-40"		C	31	252"	2120#
8 Row 22"		C	25	200"	2150#
8 Row 30"		D	41	252"	2540#
8 Row 30"	F	D	41	145"	2995#
8 Row 36-40"		D	41	328"	2615#
8 Row 36-40"	F	D	41	187"	3065#
8 Row 36-40"	FR	D	41	187"	3675#
12 Row 22"		D	37	288"	3040#
12 Row 24"		D	37	300"	3060#
12 Row 22"	F	D	37	157"	3525#
12 Row 24"	F	D	37	171"	3530#
* 12 Row 30"	F	D	61	213"	4190#
** 12 Row 30"	FR	D	61	213"	4790#
* 12 Row 30"	TRF	E	61	213"	4915#
** 12 Row 38-40"	FR	D	81	213"	5235#
* 12 Row 38-40"	TRF	D	81	267"	5345#
** 16 Row 30"	FR	D	81	267"	6085#
** 18 Row 22"	FR	D	55	246"	5670#
* 18 Row 22"	TRF	E	55	246"	5835#
** 24 Row 22"	FR	D	73	288"	7495#

MODEL 2065

Size	Toolbar	3 Pt. Hitch	# of Tines	Trans. Width	Weight
4 Row 30"		C	5	156"	1290#
4 Row 36-40"		C	5	172"	1380#
6 Row 30"		C	7	200"	1720#
6 Row 36-40"		C	7	252"	1880#
8 Row 30"		C	9	252"	2220#
8 Row 30"	F	C	9	145"	2675#
8 Row 36-40"		C	9	328"	2295#
8 Row 36-40"	F	C	9	187"	2745#
** 12 Row 30"	FR	D	13	213"	4415#
** 12 Row 30"	TRF	E	13	213"	4290#
** 12 Row 38-40"	FR	D	13	267"	4735#
** 16 Row 30"	FR	D	17	267"	5410#
* 16 Row 30"	TRF	E	17	267"	5725#

- * Two pair of support or guide wheels are recommended.
- ** Lift Assist option is recommended when mounted on 2 wheel drive tractor.

SPECIFICATIONS (Continued)

MODEL 2130

Size	Toolbar	3 Pt. Hitch	# of Tines	Trans. Width	Weight
6 Row 22"		C	19	152"	1410#
6 Row 30"		C	31	200"	1645#
8 Row 22"		C	25	200"	1795#
8 Row 30"		C	41	252"	2150#
8 Row 30"	F	C	41	145"	2605#
8 Row 30"		C	41	252"	2150#
8 Row 30"	F	C	41	145"	2605#
12 Row 22"		C	37	288"	2600#
12 Row 24"		C	37	300"	2860#
12 Row 22"	F	C	37	157"	3085#
12 Row 24"	F	C	37	171"	3095#
12 Row 30"	TRF	E	61	213"	4340#
12 Row 30"	F	D	61	213"	3615#
12 Row 30"	FR	D	61	213"	4340#
12 Row 30"	F	D	61	213"	3615#
* 12 Row 30"	FR	D	61	213"	4340#
* 12 Row 30"	TRF	E	61	213"	4210#
*** 16 Row 30"	FR	D	81	267"	5395#
*** 16 Row 30"	TRF	D	81	267"	5505#
*** 16 Row 30"	FR	D	81	267"	5395#
*** 16 Row 30"	TRF	E	81	267"	5505#
*** 18 Row 22"	FR	D	55	246"	5010#
* 18 Row 22"	TRF	E	55	246"	5000#
*** 24 Row 22"	FR	D	73	288"	6630#

MODEL 3030

Size	Toolbar	3 Pt. Hitch	Trans. Width	Weight
6 Row 22"		C	152"	1780#
6 Row 30"		C	200"	2040#
8 Row 22"		C	200"	2250#
8 Row 30"		C	252"	2640#
8 Row 30"	F	C	145"	3080#
12 Row 22"		C	288"	3180#
12 Row 22"	F	C	157"	3675#
12 Row 24"		C	300"	3205#
12 Row 24"	F	C	171"	3685#
* 12 Row 30"	TRF	E	213"	4850#
* 12 Row 30"	FR	D	213"	4780#
* 12 Row 30"	F	D	213"	4230#
* 16 Row 30"	TRF	E	267"	5795#
* 16 Row 30"	FR	D	267"	5990#
* 18 Row 22"	TRF	E	246"	5930#
*** 18 Row 22"	FR	D	246"	5865#
*** 24 Row 22"	FR	D	288"	7750#

- * Two pair of support or guide wheels are recommended.
- ** Lift Assist option is recommended when mounted on 2 wheel drive tractor.

GENERAL INFORMATION

The purpose of this manual is to assist you in operating and maintaining your row crop cultivator. Read it carefully. It furnishes information and instructions that will help you achieve years of dependable performance. These instructions have been compiled from extensive field experience and engineering data. Some information may be general in nature due to unknown and varying operating conditions. However, through experience and these instructions, you should be able to develop procedures suitable to your particular situation.

The illustrations and data used in this manual were current at the time of printing, but due to possible inline production changes, your machine may vary slightly in detail. We reserve the right to redesign and change the machines as may be necessary without notification.

Throughout this manual, references are made to right and left direction. These are determined by standing behind the equipment facing the direction of forward travel.

ABBREVIATIONS

ATF	Automatic Transmission Fluid	NF	National Fine
CE	Conforms to European Community Machinery Safety Directive 89/392/EEC	NPSM	National Pipe Straight Mechanical
CV	Constant Velocity	NPT	National Pipe Thread
F	Female	P	Pitch
GA	Gauge	psi	Pounds per Square Inch
GR (5, etc.)	Grade (5, etc.)	PTO	Power Take Off
HT	Heat Treated	QD	Quick Disconnect
m	Meter	ROPS	Roll Over Protective Structure
mm	Millimeter	SAE	Society of Automotive Engineers
M	Male	UNC	Unified Coarse
MPa	Mega Pascal	UNF	Unified Fine
N	Newton	UNS	Unified Special
NC	National Coarse		

SAFETY RULES



ATTENTION! BECOME ALERT! YOUR SAFETY IS INVOLVED!



Safety is a primary concern in the design and manufacture of our products. Unfortunately, our efforts to provide safe equipment can be wiped out by an operator's single careless act.

In addition to the design and configuration of equipment, hazard control and accident prevention are dependent upon the awareness, concern, judgement, and proper training of personnel involved in the operation, transport, maintenance and storage of equipment.

It has been said "The best safety device is an informed, careful operator." We ask you to be that kind of operator.

TRAINING

■ Safety instructions are important! Read all attachment and power unit manuals; follow all safety rules and safety decal information. (Replacement manuals are available from dealer or, in the United States and Canada, call 1-877-275-8714.) Failure to follow instructions or safety rules can result in serious injury or death.

■ Know your controls and how to stop engine and attachment quickly in an emergency.

■ If you do not understand any part of this manual and need assistance, see your dealer.

■ Operators must be instructed in and be capable of the safe operation of the equipment, its attachments and all controls. Do not allow anyone to operate this equipment without proper instructions.

■ Keep hands and body away from pressurized lines. Use paper or cardboard, not body parts to check for leaks. Wear safety goggles. Hydraulic fluid under pressure can easily penetrate skin and will cause serious injury or death.

■ Make sure that all operating and service personnel know that if hydraulic fluid penetrates skin, it must be surgically removed as soon as possible by a doctor familiar with this form of injury or gangrene, serious injury, or death will result. CONTACT A PHYSICIAN IMMEDIATELY IF FLUID ENTERS SKIN OR EYES. DO NOT DELAY.

■ Never allow children or untrained persons to operate equipment.

PREPARATION

■ Check that all hardware is properly installed. Always tighten to torque chart specifications unless instructed otherwise in this manual.

■ Air in hydraulic systems can cause erratic operation and allows loads or equipment components to drop unexpectedly. Before putting into service or allowing anyone to approach the equipment, purge any air in the system by operating all hydraulic functions several times after connecting equipment, connecting hoses, or doing any hydraulic maintenance.

■ Route hydraulic hoses carefully to prevent damage. Hoses must not be twisted, bent sharply, kinked, frayed, pinched, or come into contact with any moving parts. Operate moveable components through full operational range to check clearances. Replace any damaged hose immediately.

■ Always wear relatively tight and belted clothing to avoid entanglement in moving parts. Wear sturdy, rough-soled work shoes and protective equipment for eyes, hair, hands, hearing and head.

■ Make sure implement is properly attached, adjusted and in good operating condition.

■ Power unit must be equipped with ROPS or ROPS CAB and seat belt. Keep seat belt securely fastened. Falling off power unit can result in death from being run over or crushed. Keep foldable ROPS systems in "locked up" position at all times.

■ Make sure all safety decals are installed. Replace if damaged. (See Safety Decals section for location.)

■ A minimum 20% of tractor and equipment weight must be on tractor front wheels with attachments in transport position. Without this weight, tractor could tip over causing personal injury or death. The weight may be attained with a loader, front wheel weights, ballast in tires or front tractor weights. Weigh the tractor and equipment. Do not estimate.

OPERATIONAL SAFETY

■ Do not allow bystanders in the area when operating, attaching, removing, assembling, or servicing equipment.

■ Never walk, stand or place yourself or others under a raised wing or in the path of a lowering wing. Hydraulic system leak down, hydraulic system failures, mechanical failures or movement of control levers can cause wings to drop unexpectedly and cause severe injury or death.

■ Keep bystanders away from equipment.

■ Do not operate equipment while under the influence of alcohol or drugs.

(Safety Rules continued on next page)

SAFETY RULES



ATTENTION! BECOME ALERT! YOUR SAFETY IS INVOLVED!



(Safety Rules continued from previous page)

- Operate only in daylight or good artificial light.
- Keep hands, feet, hair and clothing away from equipment while engine is running. Stay clear of all moving parts.
- Always comply with all state and local lighting and marking requirements.
- Never allow riders on power unit or attachment.
- Power unit must be equipped with ROPS or ROPS CAB and seat belt. Keep seat belt securely fastened. Falling off power unit can result in death from being run over or crushed. Keep foldable ROPS systems in “locked up” position at all times.
- Always sit in tractor seat when operating controls or starting engine. Securely fasten seat belt, place transmission in neutral, engage brake and ensure all other controls are disengaged before starting tractor engine.
- Look down and to the rear and make sure area is clear before operating in reverse.
- Do not operate on steep slopes.
- Do not stop, start or change directions suddenly on slopes.
- Use extreme care and reduce ground speed on slopes and rough terrain.
- Watch for hidden hazards on the terrain during operation.
- Stop tractor and implement immediately upon striking an obstruction. Turn off engine, remove key, inspect and repair any damage before resuming operation.
- **AVOID INJURY OR DEATH FROM POWER LINES:**
 - Stay away from power lines.
 - Electrocution can occur without direct contact.
 - Check clearances before raising implement.
 - Do not leave the operator’s seat if any part of the tractor or implement contacts electric lines.
- Before folding or unfolding cultivator:
 - Make sure you have adequate clearance on each side and overhead.
 - Make sure wing cylinder restrictor fittings are properly installed.
 - Make sure wing-mounted gauge wheels and guide coulters will not contact tractor cab or tires.

- Before dismounting tractor or performing any service or maintenance, disengage power to implement, lower the 3-point hitch and all raised components to the ground, operate valve levers to release any hydraulic pressure, set parking brake, stop engine, remove key, and unfasten seat belt.
- Before servicing, unfold completely to operating position. Do not service with wings in any other position.
- Never go underneath equipment lowered to the ground or raised. Never place any part of the body underneath equipment or between moveable parts even when the engine has been turned off. Hydraulic system leak down, hydraulic system failures, mechanical failures or movement of control levers can cause equipment to drop or rotate unexpectedly and cause severe injury or death.
 - Service work does not require going underneath.
 - Read operator’s manual for service instructions or have done by a qualified dealer.

MAINTENANCE SAFETY

- Service and maintenance work not covered in OWNER SERVICE must be done by a qualified dealership. Special skills, tools and safety procedures may be required. Failure to follow these instructions can result in serious injury or death.
- Before servicing, unfold completely to operating position. Do not service with wings in any other position.
- Never go underneath equipment lowered to the ground or raised. Never place any part of the body underneath equipment or between moveable parts even when the engine has been turned off. Hydraulic system leak down, hydraulic system failures, mechanical failures or movement of control levers can cause equipment to drop or rotate unexpectedly and cause severe injury or death.
 - Service work does not require going underneath.
 - Read operator’s manual for service instructions or have done by a qualified dealer.
- Make sure implement is properly attached, adjusted and in good operating condition.
- Keep all persons away from operator control area while performing adjustments, service or maintenance.
- Do not handle blades with bare hands. Careless or improper handling may result in serious injury.

SAFETY RULES



ATTENTION! BECOME ALERT! YOUR SAFETY IS INVOLVED!



- Tighten all bolts, nuts and screws to torque chart specifications. Check that all cotter pins are installed securely to ensure equipment is in a safe condition before operating.
- Make sure all safety decals are installed. Replace if damaged. (See Safety Decals section for location.)
- Do not disconnect hydraulic lines until machine is securely blocked or placed in lowest position and system pressure is released by operating valve levers.
- Do not modify or alter or permit anyone else to modify or alter the equipment or any of its components in any way.
- Your dealer can supply original equipment hydraulic accessories and repair parts. Substitute parts may not meet original equipment specifications and may be dangerous.
- To prevent contamination, clean and then cover hose ends, fittings and motor ports with tape.

- Always wear relatively tight and belted clothing to avoid entanglement in moving parts. Wear sturdy, rough-soled work shoes and protective equipment for eyes, hair, hands, hearing and head.
- Do not allow bystanders in the area when operating, attaching, removing, assembling, or servicing equipment.
- Before dismounting tractor or performing any service or maintenance, disengage power to implement, lower the 3-point hitch and all raised components to the ground, operate valve levers to release any hydraulic pressure, set parking brake, stop engine, remove key, and unfasten seat belt.

STORAGE

- Block equipment securely for storage.
- Keep children and bystanders away from storage area.

NOTES

SAFETY & INSTRUCTIONAL DECALS



ATTENTION! BECOME ALERT! YOUR SAFETY IS INVOLVED!



Replace Immediately If Damaged!

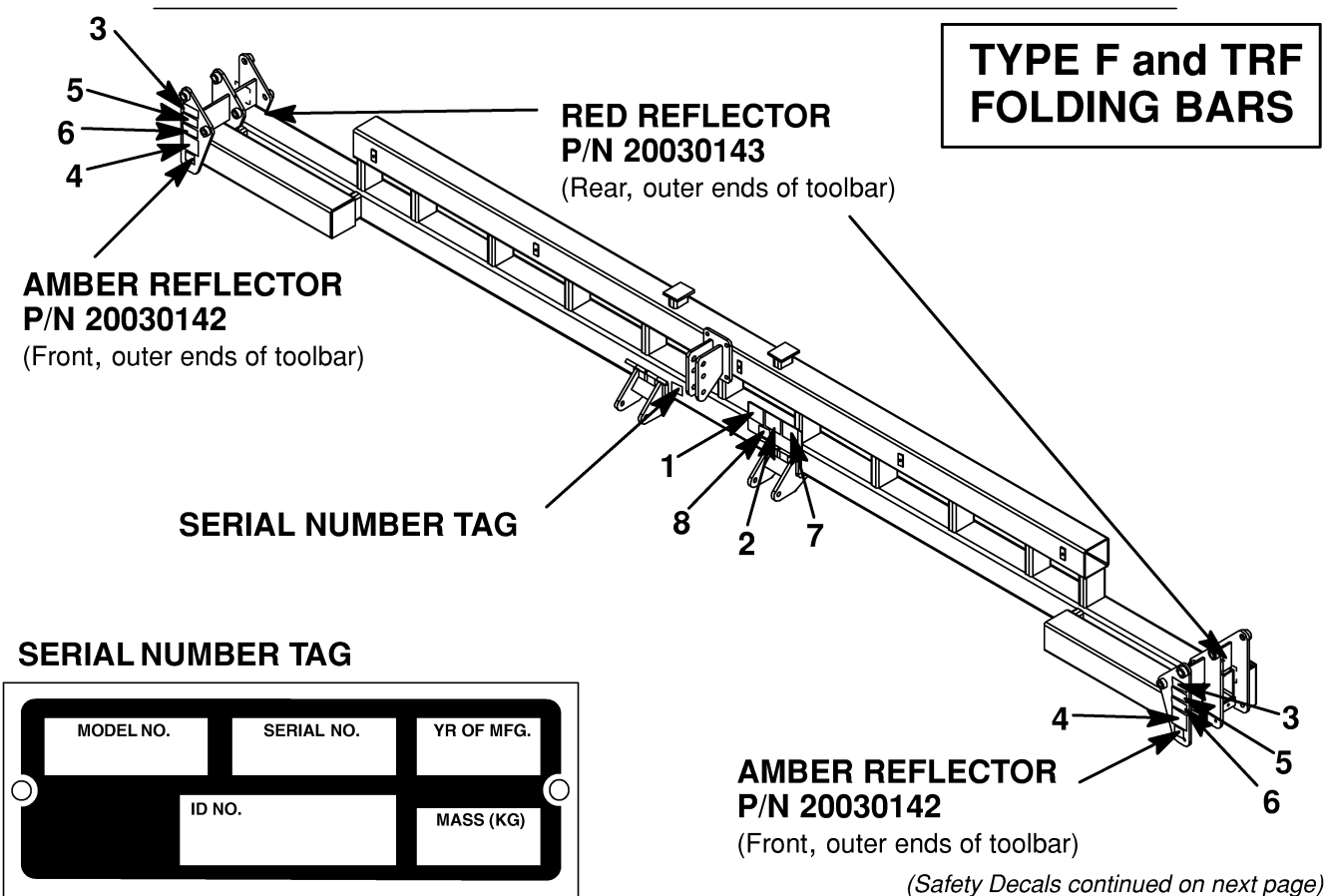
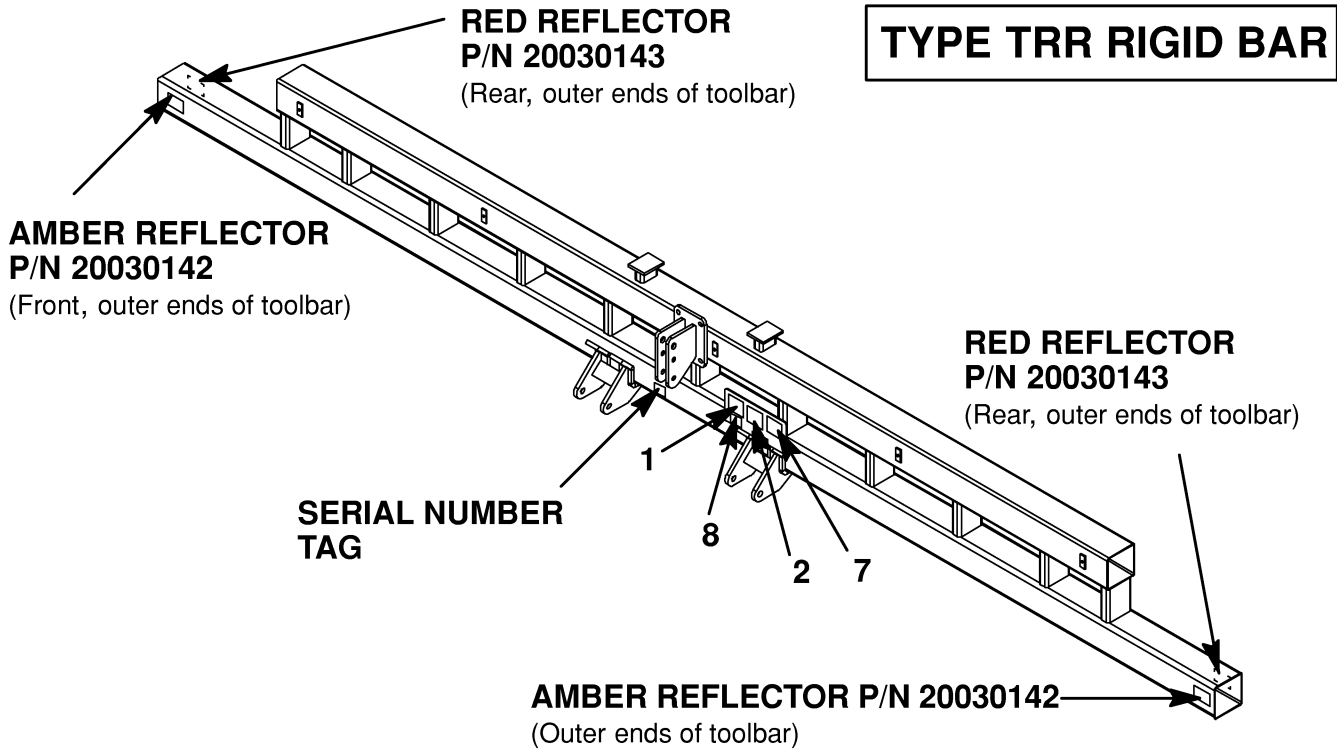

SERIAL NUMBER TAG

MODEL NO.	SERIAL NO.	YR OF MFG.
ID NO.		MASS (KG)

(Safety Decals continued on next page)

SAFETY & INSTRUCTIONAL DECALS



ATTENTION! BECOME ALERT! YOUR SAFETY IS INVOLVED!



Replace Immediately If Damaged!

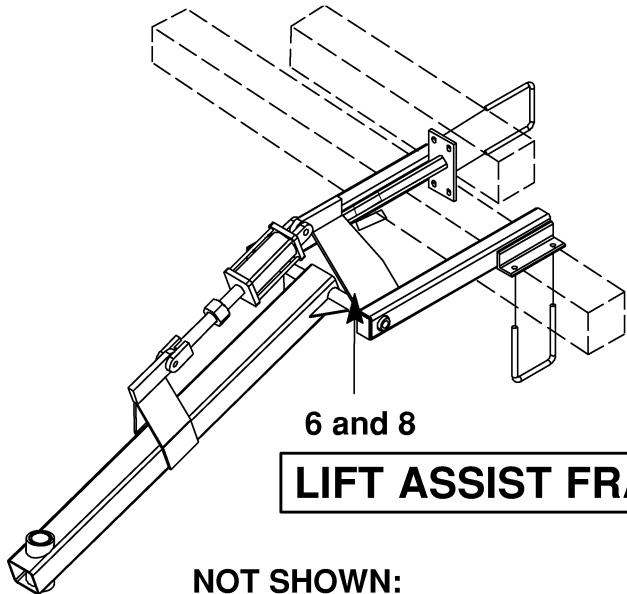

LIFT ASSIST FRAME

NOT SHOWN:

- PN-20033700 – 2040 Model Decal
- PN-20032618 – 2065 Model Decal
- PN-20033704 – 2130 Model Decal
- PN-20033703 – 3030 Model Decal



WARNING

IMPLEMENT CAN TIP OVER AND CRUSH IF ATTACHED, REMOVED OR STORED IMPROPERLY.

- Read and follow Operator's Manual instructions and safety rules for procedures and use of parking stands.
- Front parking stands must be on all cultivators.
- Rear parking stands must be on all folding cultivators unless cultivator has rear lift assist.
- Parking stands must be kept in good condition or replaced if damaged.
- Remove on solid, level ground.
- Cultivator must be level and stable with parking stands properly positioned and rear lift assist (when equipped) lowered to rest on cylinder stops before removing from tractor.
- Keep all bystanders away.

Failure to follow these instructions can result in serious injury or death.

20033891

7 – PN 20033891



WARNING

TO AVOID SERIOUS INJURY OR DEATH:

- Read Operator's Manual before operating, servicing or repairing equipment. Follow all safety rules and instructions. (Manuals are available from dealer or, in the United States and Canada, call 1-800-319-6637.)
- Operate from tractor seat only.
- Lower equipment to ground, stop engine, remove key and set brake before dismantling tractor.
- Allow no children or untrained persons to operate equipment.

FAILURE TO FOLLOW THESE INSTRUCTIONS CAN RESULT IN INJURY OR DEATH.

55122-B

1 - P/N 55122

3 - P/N 20033890

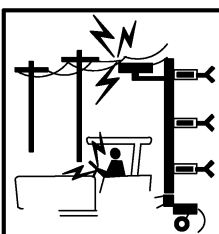

DANGER

To avoid injury or death, do not contact electric lines.

20033890

2 - P/N 20033887



WARNING

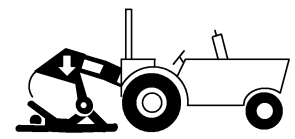
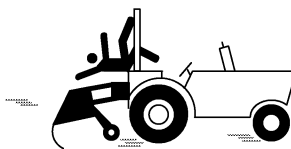

FALLING OFF CAN RESULT IN BEING RUN OVER.

- Tractor must be equipped with ROPS (or ROPS CAB) and seat belt. Keep foldable ROPS systems in "locked up" position at all times.
- Buckle Up! Keep seat belt securely fastened.
- Allow no riders.

RAISED IMPLEMENT CAN DROP AND CRUSH.

- Never go underneath raised implement which can drop from equipment or tractor 3-point hitch hydraulic leak down, hydraulic system failures, movement of control levers or mechanical linkage failures.
- Service work does not require going underneath implement. Read manual instructions.

FALLING OFF OR GOING UNDERNEATH IMPLEMENT CAN RESULT IN SERIOUS INJURY OR DEATH.

20033887

SAFETY & INSTRUCTIONAL DECALS

⚠ ATTENTION! BECOME ALERT! YOUR SAFETY IS INVOLVED! ⚠

Replace Immediately If Damaged!

⚠ WARNING

Air in hydraulic systems can allow wings or other components to fall rapidly when being raised or lowered. Before operating or allowing anyone to approach the equipment, purge all air from the system by operating all hydraulic functions several times.

20033889

4 - P/N 20033889



19924-B

⚠ WARNING

HIGH-PRESSURE HYDRAULIC OIL LEAKS CAN PENETRATE SKIN RESULTING IN SERIOUS INJURY, GANGRENE OR DEATH.

- Check for leaks with cardboard; never use hand.
- Before loosening fittings: lower load, release pressure, and be sure oil is cool.
- Consult physician immediately if skin penetration occurs.

6 - P/N 19924

5 - P/N 20033888

8 - P/N 20033893

IMPORTANT

Do not use upper 3-point top link when cultivator is equipped with rear lift assist. Damage will occur to equipment.

20033893



⚠ WARNING

To avoid injury or death, stand clear of machine when wings are being folded or unfolded. Mechanical failure, hydraulic system failure, or air in hydraulic system can allow wings to fall rapidly.

20033888

BOLT SIZE CHART

NOTE: Chart shows bolt thread sizes and corresponding head (wrench) sizes for standard SAE and Metric Bolts.

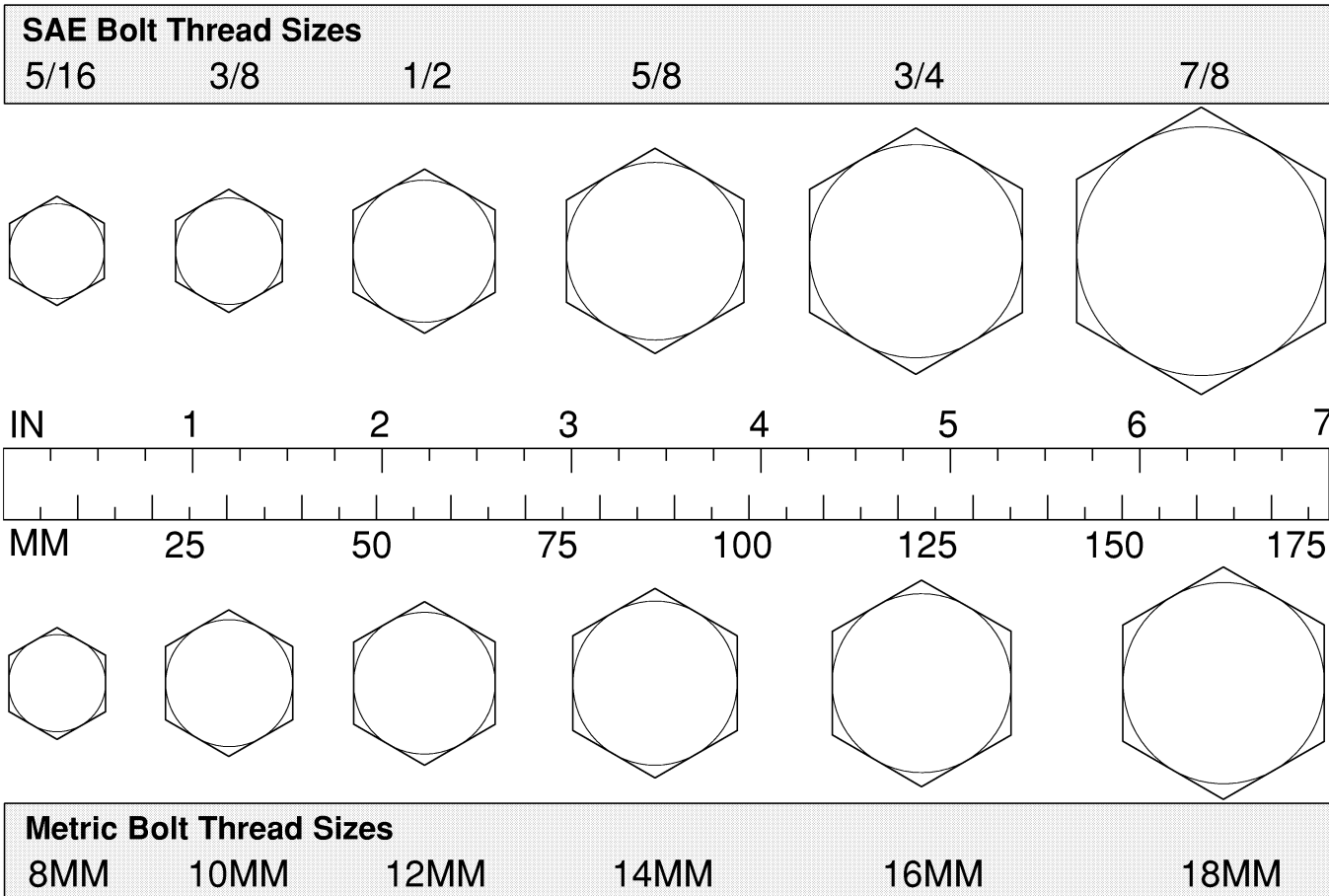

BOLT TORQUE CHART

Always tighten hardware to these values unless a different torque value or tightening procedure is listed for a specific application.

Fasteners must always be replaced with the same grade as specified in the manual parts list.

Always use the proper tool for tightening hardware: SAE for SAE hardware and Metric for metric hardware.

Make sure fastener threads are clean and you start thread engagement properly.

All torque values are given to specifications used on hardware defined by SAE J1701 & J1701M JUL96.

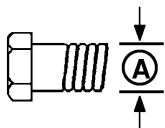

SAE SERIES TORQUE CHART

 SAE Bolt Head Identification
SAE Grade 2 (No Dashes)

 SAE Bolt Head Identification
SAE Grade 5 (3 Radial Dashes)

 SAE Bolt Head Identification
SAE Grade 8 (6 Radial Dashes)

Ⓐ Diameter (Inches)	Wrench Size	MARKING ON HEAD					
		SAE 2		SAE 5		SAE 8	
		Lbs.-Ft.	N-m	Lbs.-Ft.	N-m	Lbs.-Ft.	N-m
1/4	7/16"	6	8	10	13	14	18
5/16	1/2"	12	17	19	26	27	37
3/8	9/16"	23	31	35	47	49	67
7/16	5/8"	36	48	55	75	78	106
1/2	3/4"	55	75	85	115	120	163
9/16	13/16"	78	106	121	164	171	232
5/8	15/16"	110	149	170	230	240	325
3/4	1-1/8"	192	261	297	403	420	569
7/8	1-5/16"	306	416	474	642	669	907
1	1-1/2"	467	634	722	979	1020	1383

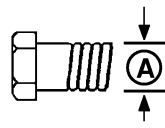

METRIC SERIES TORQUE CHART

 Metric Bolt Head Identification
Metric Grade 8.8

 Metric Bolt Head Identification
Metric Grade 10.9

Diameter & Thread Pitch (Millimeters)	Wrench Size	COARSE THREAD				FINE THREAD				Diameter & Thread Pitch (Millimeters)
		MARKING ON HEAD				MARKING ON HEAD				
		Metric 8.8		Metric 10.9		Metric 8.8		Metric 10.9		
		N-m	Lbs.-Ft.	N-m	Lbs.-Ft.	N-m	Lbs.-Ft.	N-m	Lbs.-Ft.	
6 x 1.0	10 mm	8	6	11	8	8	6	11	8	6 x 1.0
8 x 1.25	13 mm	20	15	27	20	21	16	29	22	8 x 1.0
10 x 1.5	16 mm	39	29	54	40	41	30	57	42	10 x 1.25
12 x 1.75	18 mm	68	50	94	70	75	55	103	76	12 x 1.25
14 x 2.0	21 mm	109	80	151	111	118	87	163	120	14 x 1.5
16 x 2.0	24 mm	169	125	234	173	181	133	250	184	16 x 1.5
18 x 2.5	27 mm	234	172	323	239	263	194	363	268	18 x 1.5
20 x 2.5	30 mm	330	244	457	337	367	270	507	374	20 x 1.5
22 x 2.5	34 mm	451	332	623	460	495	365	684	505	22 x 1.5
24 x 3.0	36 mm	571	421	790	583	623	459	861	635	24 x 2.0
30 x 3.0	46 mm	1175	867	1626	1199	1258	928	1740	1283	30 x 2.0

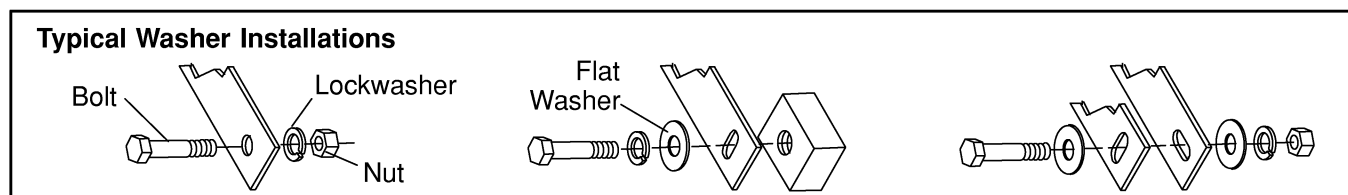

OPERATION

Safety is a primary concern in the design and manufacture of our products. Unfortunately, our efforts to provide safe equipment can be wiped out by an operator's single careless act.

In addition to the design and configuration of equipment, hazard control and accident prevention are dependent upon the awareness, concern, judgement, and proper training of personnel involved in the operation, transport, maintenance and storage of equipment.

It has been said "The best safety device is an informed, careful operator." We ask you to be that kind of operator.



CAUTION

- If you do not understand any part of this manual and need assistance, see your dealer.
- Always wear relatively tight and belted clothing to avoid entanglement in moving parts. Wear sturdy, rough-soled work shoes and protective equipment for eyes, hair, hands, hearing and head.



WARNING

- Know your controls and how to stop engine and attachment quickly in an emergency.
- Keep hands and body away from pressurized lines. Use paper or cardboard, not body parts to check for leaks. Wear safety goggles. Hydraulic fluid under pressure can easily penetrate skin and will cause serious injury or death.
- Make sure that all operating and service personnel know that if hydraulic fluid penetrates skin, it must be surgically removed as soon as possible by a doctor familiar with this form of injury or gangrene, serious injury, or death will result. CONTACT A PHYSICIAN IMMEDIATELY IF FLUID ENTERS SKIN OR EYES. DO NOT DELAY.
- Never allow children or untrained persons to operate equipment.
- Keep bystanders away from equipment.
- A minimum 20% of tractor and equipment weight must be on tractor front wheels with attachments in transport position. Without this weight, tractor could tip over causing personal injury or death. The weight may be attained with a loader, front wheel weights, ballast in tires or front tractor weights. Weigh the tractor and equipment. Do not estimate.
- Before dismounting tractor or performing any service or maintenance, disengage power to implement, lower the 3-point hitch and all raised components to the ground, operate valve levers to release any hydraulic pressure, set parking brake, stop engine, remove key, and unfasten seat belt.



WARNING

- Never go underneath equipment lowered to the ground or raised. Never place any part of the body underneath equipment or between moveable parts even when the engine has been turned off. Hydraulic system leak down, hydraulic system failures, mechanical failures or movement of control levers can cause equipment to drop or rotate unexpectedly and cause severe injury or death.
 - Service work does not require going underneath.
 - Read operator's manual for service instructions or have done by a qualified dealer.



DANGER

- AVOID INJURY OR DEATH FROM POWER LINES:
 - Stay away from power lines.
 - Electrocution can occur without direct contact.
 - Check clearances before raising implement.
 - Do not leave the operator's seat if any part of the tractor or implement contacts electric lines.



WARNING

- Implement can tip over and crush if attached, removed, or stored improperly.
 - Read and follow instructions and safety rules for procedures and use of parking stands.
 - Front parking stands must be on all cultivators.
 - Rear parking stands must be on all folding cultivators unless cultivator has rear lift assist.
 - Parking stands must be kept in good condition and replaced if damaged.
 - Remove on solid, level ground.
 - Cultivator must be level and stable with parking stands properly positioned and rear lift assist (when equipped) lowered to rest on cylinder stops before removing from tractor.
 - Keep all bystanders away.
- Before folding or unfolding cultivator:
 - Make sure you have adequate clearance on each side and overhead.
 - Make sure wing cylinder restrictor fittings are properly installed.
 - Make sure wing-mounted gauge wheels and guide coulters will not contact tractor cab or tires.

PRE-OPERATION CHECK LIST

(OWNER'S RESPONSIBILITY)

- ___ Review and follow all safety rules and safety decal instructions on pages 5 through 10.
- ___ Check that all safety decals are installed and in good condition. Replace if damaged.
- ___ Check that all hardware and cotter pins are properly installed and secured.
- ___ Check that equipment is properly and securely attached to tractor.
- ___ Do not allow riders.
- ___ Check all lubrication points and grease as instructed in "Service, lubrication information."
- ___ Check hydraulic reservoir level.
- ___ Check that all hydraulic hoses and fittings are in good condition and not leaking before starting tractor. Check that hoses are not twisted, bent sharply, kinked, frayed or pulled tight. Replace any damaged hoses immediately.
- ___ Raise and lower equipment and wings to make sure air is purged from hydraulic cylinder and hose.
- ___ Make sure tractor 3-point lift links do not interfere with hydraulic hoses.
- ___ Make sure tractor ROPS or ROPS CAB and seat belt are in good condition. Keep seat belt securely fastened during operation.
- ___ Before starting engine, operator must be in tractor seat with seat belt fastened. Place transmission in neutral or park, engage brake and disengage tractor PTO.

ATTACHING & REMOVING CULTIVATOR

Attaching Cultivator to Tractor with Quick-Hitch (Figure 1)

The cultivator should always be located on a solid, level, dry area that is free of debris and other foreign objects.

Before attaching cultivator to tractor be sure hitch pins and spacers are completely assembled to match the hitch configuration of your tractor as shown in Figure 1.

Set the height of the 3-point hitch so the quick-hitch coupler is lower than the mounting pins.

Be sure the lower links on the tractor are set in the free float position (see tractor manual for details).

Be sure the 3-point hitch is set in the sway position (see tractor manual for details).

Align the couplers under the mounting pins while backing up.

NOTE: Use the proper size bushings for lower link mounting pins and correct upper link pin location for Category II, III, or III N operation.

Make sure there are no bystanders in the area.

Carefully back up, until the coupler hooks align with cultivator hitch pins.

When the coupler is under the pins, slowly raise the 3-point hitch. Be sure each of the mounting pins seat in their respective coupler hooks.

Stop engine, set parking brake, wait for all moving parts to stop and remove ignition key before dismounting.

Release the coupler retainer locks to secure the mounting pins in the coupler.

Clean the hydraulic couplers and fittings to avoid oil contamination.

Connect hydraulic couplings. Couplings must be completely engaged.

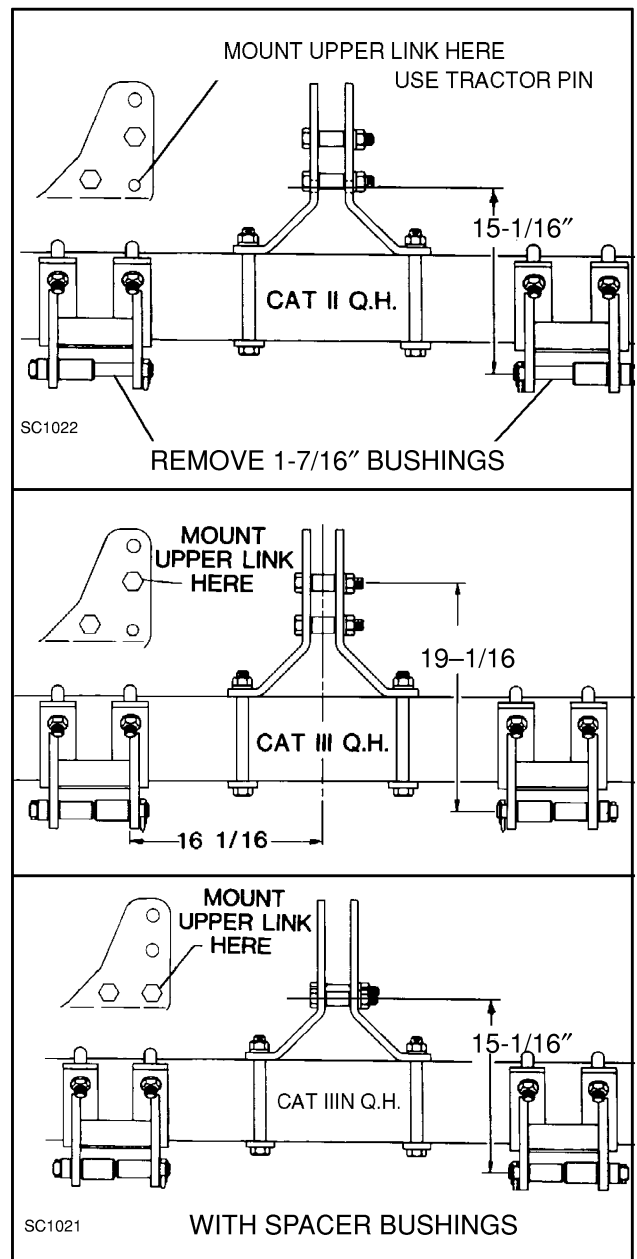

Figure 1. Quick Hitch Configuration

Wing fold hydraulic lines should be connected to the tractor #1 hydraulic couplers. Couplers must be connected so that pushing the control lever forward moves (unfolds) the wings to operating position and pulling the lever rearward moves (folds) the wings to transport position.

Lift assist hydraulic lines should be connected to the tractor #2 hydraulic couplers. Couplers must be connected so that pushing the control lever forward lowers the cultivator and pulling the lever rearward raises the cultivator.

WARNING

■ Air in hydraulic systems can cause erratic operation and allows loads or equipment components to drop unexpectedly. Before putting into service or allowing anyone to approach the equipment, purge any air in the system by operating all hydraulic functions several times after connecting equipment, connecting hoses, or doing any hydraulic maintenance.

Connect 7-pin electrical connector to tractor.

Raise tool bar slightly.

Stop engine, set parking brake, wait for all moving parts to stop and remove ignition key before dismounting.

Raise all parking stands into upper position and install pin through parking stands and bracket as shown in Figure 2.

IMPORTANT

■ To prevent damage, raise parking stands to upper position before moving cultivator.

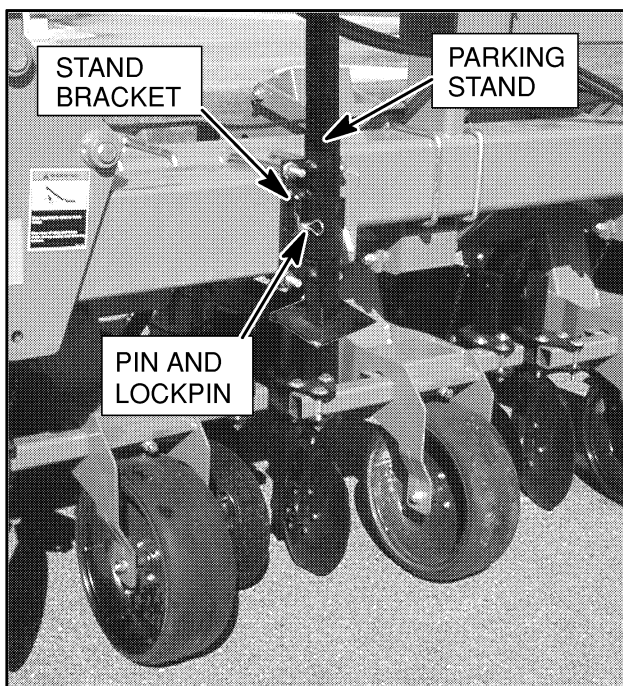

Figure 2. Parking Stand Raised and Pinned (Typical toolbar shown)

Attaching Cultivator to Tractor Without Quick-Hitch (Figure 3)

The cultivator should always be located on a solid, level, dry area that is free of debris and other foreign objects.

Before attaching cultivator to tractor be sure hitch pins and spacers are completely assembled to match the hitch configuration of your tractor as shown in Figure 3.

Make sure there are no bystanders in the area.

Remove 3-point hitch lower pins and upper link bolt. Back tractor and align lower links with hitch pins.

Stop engine, set parking brake, wait for all moving parts to stop and remove ignition key before dismounting.

Install pins with correct bushings and secure quick-lock pins. Align upper link and fasten with bolt and spacer bushing (or upper link pin, CATII hitches).

Clean the hydraulic couplers and fittings to avoid oil contamination. Connect hydraulic couplings. Couplings must be completely engaged.

WARNING

■ Air in hydraulic systems can cause erratic operation and allows loads or equipment components to drop unexpectedly. Before putting into service or allowing anyone to approach the equipment, purge any air in the system by operating all hydraulic functions several times after connecting equipment, connecting hoses, or doing any hydraulic maintenance.

Wing fold hydraulic lines should be connected to the tractor #1 hydraulic couplers. Couplers must be connected so that pushing the control lever forward moves (unfolds) the wings to operating position and pulling the lever rearward moves (folds) the wings to transport position.

Lift assist hydraulic lines should be connected to the tractor #2 hydraulic couplers. Couplers must be connected so that pushing the control lever forward lowers the cultivator and pulling the lever rearward raises the cultivator.

Connect 7-pin electrical connector to tractor. Raise tool bar slightly.

Stop engine, set parking brake, wait for all moving parts to stop and remove ignition key before dismounting. Raise all parking stands into upper position and install pin through parking stand and bracket as shown in Figure 2.

IMPORTANT

■ To prevent damage, raise parking stands to upper position before moving cultivator.

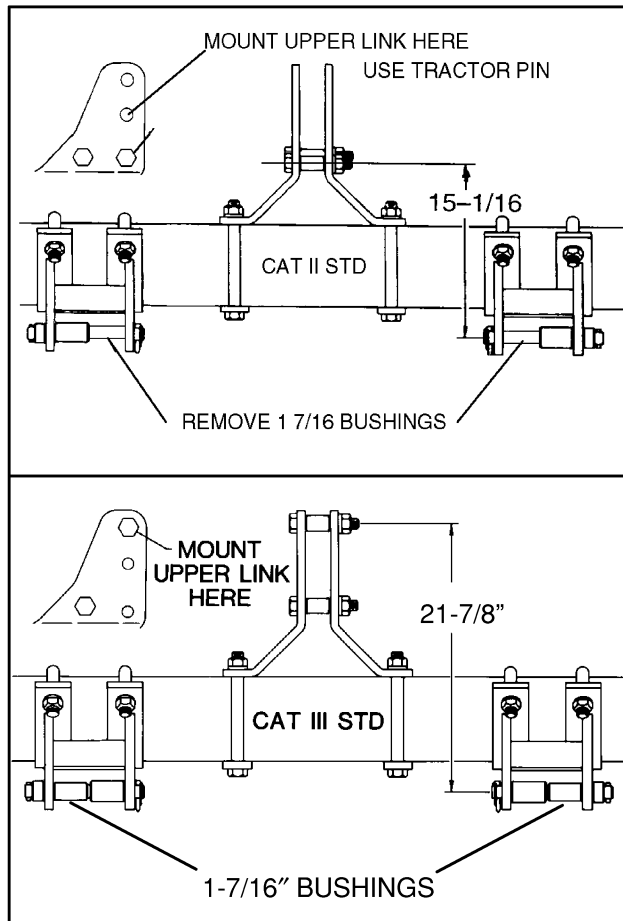

Figure 3. Standard Hitch Configuration

Removing Cultivator from Tractor

WARNING

■ Implement can tip over and crush if attached, removed, or stored improperly.

- Read and follow instructions and safety rules for procedures and use of parking stands.
- Front parking stands must be on all cultivators.
- Rear parking stands must be on all folding cultivators unless cultivator has rear lift assist.
- Parking stands must be kept in good condition and replaced if damaged.
- Remove on solid, level ground.
- Cultivator must be level and stable with parking stands properly positioned and rear lift assist (when equipped) lowered to rest on cylinder stops before removing from tractor.
- Keep all bystanders away.

RIGID CULTIVATORS OR WING CULTIVATORS REMOVED IN OPERATING POSITION (WINGS UNFOLDED)

Park cultivator on a solid, level, surface that is free of debris and other foreign objects.

Be sure bystanders are clear from working area.

Lower lift assist wheels (if equipped) to rest on cylinder stops.

Lower cultivator so that sweeps and gauge or guide wheels rest on the ground. Position toolbar in the operating position so that cultivator linkage is nearly horizontal as shown in Figure 15.

Stop engine, set parking brake, wait for all moving parts to stop and remove ignition key before dismounting.

Lower front parking stands to the ground and pin in position so that parking stands will be vertical when tractor is removed.

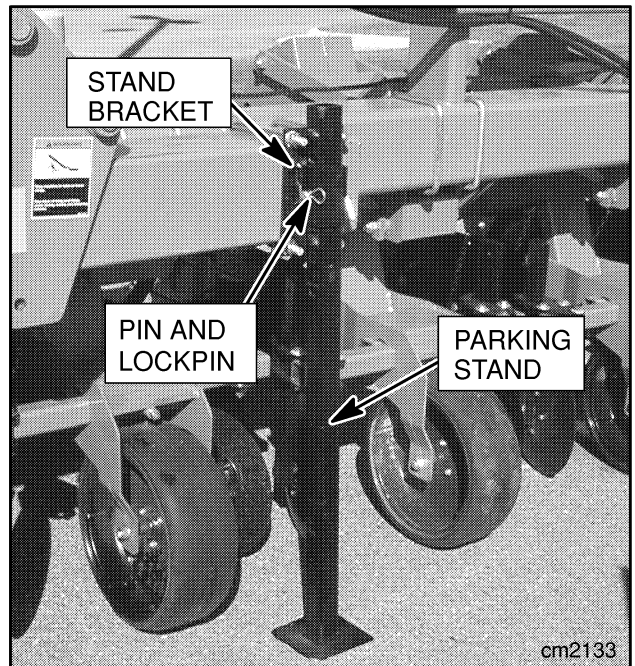

Figure 4. Front Parking Stand Lowered and Pinned (Typical toolbar shown)

Relieve hydraulic pressure in wing fold and lift assist cylinders (if equipped).

Adjust center link as necessary to remove load from hitch.

With Quick-Hitch: Release coupler latches and lower hitch to release hitch pins.

Without Quick-Hitch: Remove hitch pins from upper and lower hitch links.

Disconnect hydraulic couplers and electrical connector from tractor.

Move tractor away from cultivator.

WING CULTIVATORS REMOVED IN TRANSPORT POSITION (WINGS FOLDED)

Park cultivator on a solid, level, surface that is free of debris and other foreign objects.

Be sure bystanders are clear from working area.

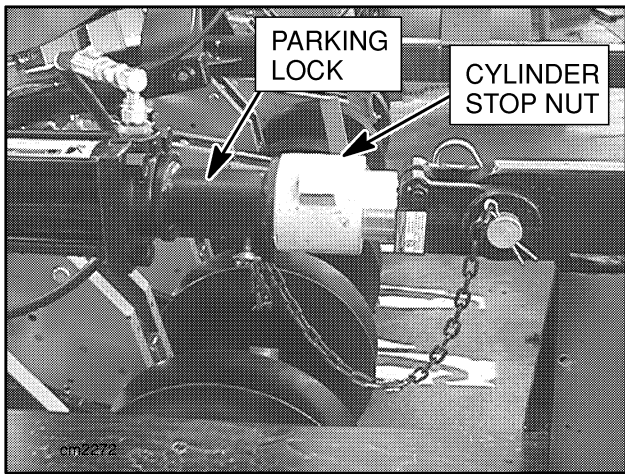

Figure 5. Lift Assist Parking Locks Installed

With Lift assist, install parking locks on lift assist cylinders and lower cultivator to rest on stops. Adjust cylinder stop nuts to level bring cultivator to a level parked position.

Lower cultivator so that sweeps and gauge or guide wheels rest on the ground. Position toolbar in the operating position so that cultivator linkage is nearly horizontal as shown in Figure 15.

Stop engine, set parking brake, wait for all moving parts to stop and remove ignition key before dismounting.

Lower front parking stands to the ground and pin in position so that parking stands will be vertical when tractor is removed.

Lower rear parking stands (folding cultivators without lift assist) to the ground and pin in position so that parking stands will be vertical when tractor is removed. Front and rear stands should be pinned in the same hole position.

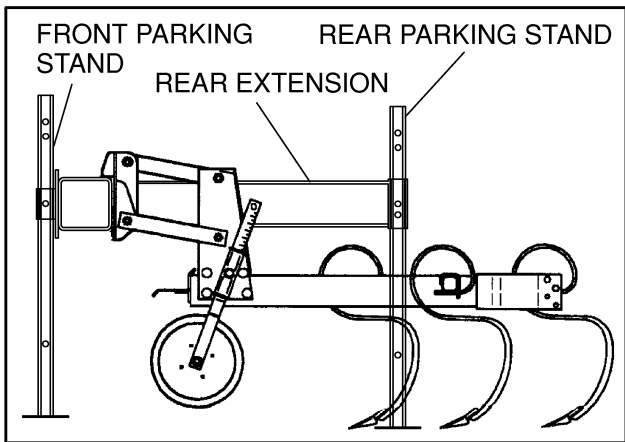

Figure 6. Front and Rear Parking Stands (Type F Toolbar)

Relieve hydraulic pressure in wing fold and lift assist cylinders. Adjust center link as necessary to remove load from hitch.

With Quick-Hitch: Release coupler latches and lower hitch to release hitch pins.

Without Quick-Hitch: Remove hitch pins from upper and lower hitch links.

Disconnect hydraulic couplers and electrical connector from tractor. Move tractor away from cultivator.

WING CULTIVATORS EQUIPPED WITH LIFT ASSIST WHEELS

Park cultivator on a solid, level, surface that is free of debris and other foreign objects.

Be sure bystanders are clear from working area.

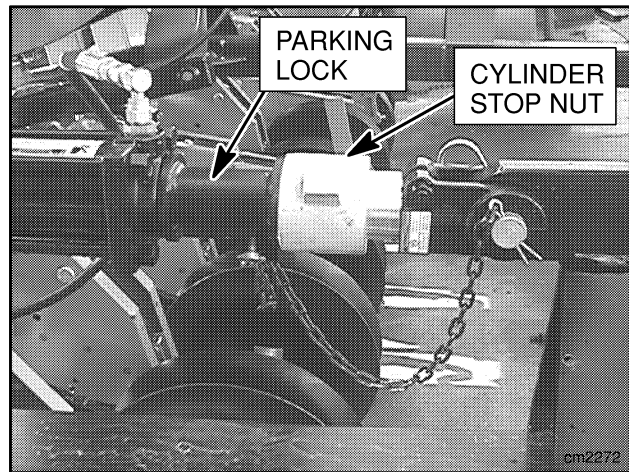

Figure 7. Lift Assist Parking Locks Installed

Install parking locks on lift assist cylinders and lower cultivator to rest on stops. Adjust cylinder stop nuts to level bring cultivator to a level parked position.

Lower cultivator so that sweeps and gauge or guide wheels rest on the ground. Position toolbar in the operating position so that cultivator linkage is nearly horizontal as shown in Figure 11.

Stop engine, set parking brake, wait for all moving parts to stop and remove ignition key before dismounting.

Lower front parking stands to the ground and pin in position so that parking stands will be vertical when tractor is removed.

Relieve hydraulic pressure in wing fold and lift assist cylinders.

Adjust center link as necessary to remove load from hitch.

(With Quick-Hitch) Release coupler latches and lower hitch to release hitch pins.

(Without Quick-Hitch) Remove hitch pins from upper and lower hitch links.

Disconnect hydraulic couplers and electrical connector from tractor.

Move tractor away from cultivator.

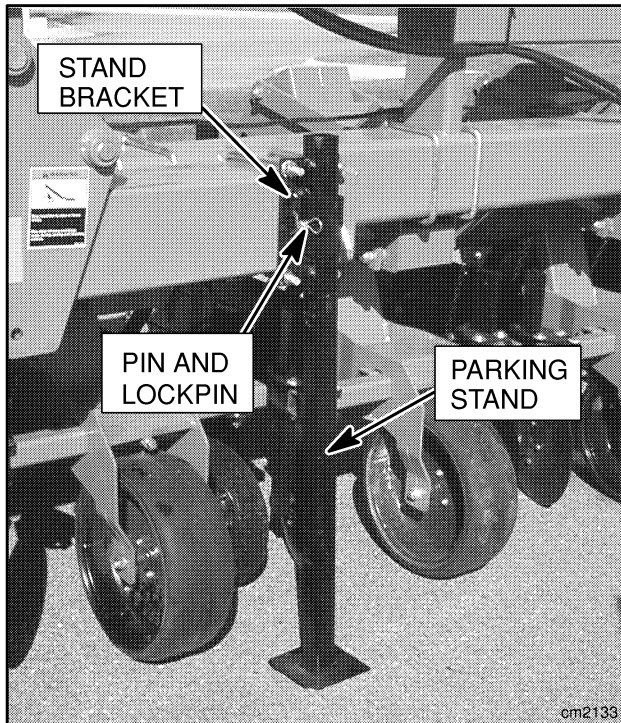

Figure 8. Front Parking Stand Lowered and Pinned (Typical toolbar shown)

See your tractor operator's manual for instructions on warning light and turn signal operation.

If warning lights, turn signals, and tail lights do not function correctly, see your Alloway dealer.

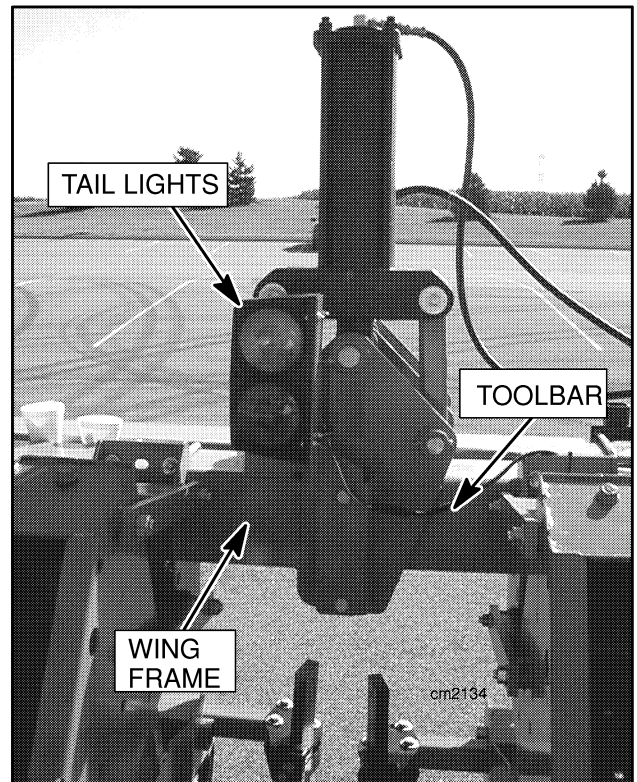

Figure 10. Tail Light (Folding Bar, left side shown)

Electrical System (Figure 9)

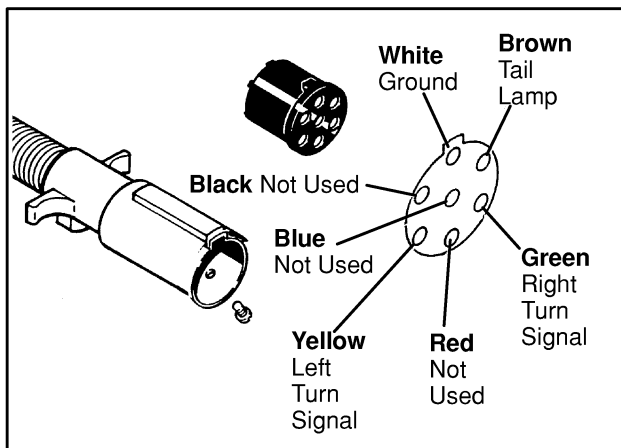

Figure 9. 7-Pin Electrical Connector

The tractor must be equipped with a SAE J560a 7-pin electrical connector. This will provide power for turn signals, warning flashers, and tail lights.

The cultivator is equipped with warning flashers and turn signals located on each end of the main tool bar. Warning lights must be functional whenever the harvester is transported on public highways.

Front Parking Stands

Front Parking stands are supplied with all cultivators. Front stands must be installed to support the cultivator whenever cultivator is removed from the tractor.

Lower front parking stands to the ground and pin in position so that parking stands will be vertical when tractor is removed as shown in Figure 11.

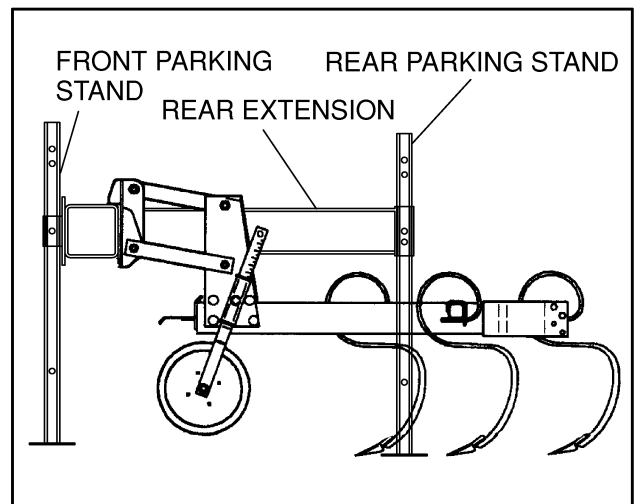

Figure 11. Front and Rear Parking Stands (Type F Toolbar)

Rear Parking Stands

Rear Parking stands are supplied with all folding toolbar cultivators without rear lift assist wheels. Either Rear parking stands or lift assist wheels must be installed to support the cultivator whenever cultivator is removed in the folded transport position.

Lower rear parking stands (folding cultivators without lift assist) to the ground and pin in position so that parking stands will be vertical when tractor is removed. Front and rear stands should be pinned in the same hole position as shown in Figure 11.

FOLDING CULTIVATOR



WARNING

■ Never walk, stand or place yourself or others under a raised wing or in the path of a lowering wing. Hydraulic system leak down, hydraulic system failures, mechanical failures or movement of control levers can cause wings to drop unexpectedly and cause severe injury or death.



DANGER

■ AVOID INJURY OR DEATH FROM POWER LINES:

- Stay away from power lines.
- Electrocutation can occur without direct contact.
- Check clearances before raising implement.
- Do not leave the operator's seat if any part of the tractor or implement contacts electric lines.



WARNING

■ Before folding or unfolding cultivator:

- Make sure you have adequate clearance on each side and overhead.
- Make sure wing cylinder restrictor fittings are properly installed.
- Make sure wing-mounted gauge wheels and guide coulters will not contact tractor cab or tires.

Cultivator must be properly attached to the tractor with wing fold hydraulic lines connected to the tractor #1 hydraulic couplers. Couplers must be connected so that pushing the control lever forward moves (unfolds) the wings to operating position and pulling the lever rearward moves (folds) the wings to transport position.

Position tractor and cultivator in a level area, free of overhead obstacles.

Using tractor 3-point hitch and lift assist wheels (if equipped), raise cultivator to a level position off the ground.

Activate fold control lever rearward and move cultivator wings until they contact the wing rests attached to the main frame. Raise the cultivator into transport position.

UNFOLDING CULTIVATOR



WARNING

■ Never walk, stand or place yourself or others under a raised wing or in the path of a lowering wing. Hydraulic system leak down, hydraulic system failures, mechanical failures or movement of control levers can cause wings to drop unexpectedly and cause severe injury or death.



DANGER

■ AVOID INJURY OR DEATH FROM POWER LINES:

- Stay away from power lines.
- Electrocutation can occur without direct contact.
- Check clearances before raising implement.
- Do not leave the operator's seat if any part of the tractor or implement contacts electric lines.



WARNING

■ Before folding or unfolding cultivator:

- Make sure you have adequate clearance on each side and overhead.
- Make sure wing cylinder restrictor fittings are properly installed.
- Make sure wing-mounted gauge wheels and guide coulters will not contact tractor cab or tires.

Cultivator must be properly attached to the tractor with wing fold hydraulic lines connected to the tractor #1 hydraulic couplers. Couplers must be connected so that pushing the control lever forward moves (unfolds) the wings to operating position and pulling the lever rearward moves (folds) the wings to transport position.

Position tractor and cultivator in a level area free of overhead obstacles and with enough clear area to permit the cultivator to unfold.

Using the tractor 3-point hitch and lift assist wheels (if equipped), raise cultivator to a level position off the ground. Activate fold control lever forward and move cultivator wings off wing rests into operating position.

LIFT ASSIST

3-Point Hitch Semi-Mounted Cultivator

IMPORTANT

■ If the cultivator is used with lift assist wheels, it must be operated as a semi-mounted unit to prevent damage to the 3-point hitch components. Remove the upper link mast and attach the cultivator to the lower 3-point hitch links only. Lift assist wheels will always carry part of the cultivator weight.

Lift assist hydraulic lines should be connected to the tractor #2 hydraulic couplers. Couplers must be connected so that pushing the control lever forward lowers the cultivator and pulling the lever rearward raises the cultivator.

Adjustable cylinder stop nuts on the lift assist cylinders are used to level and control the operating position of the rear of cultivator.

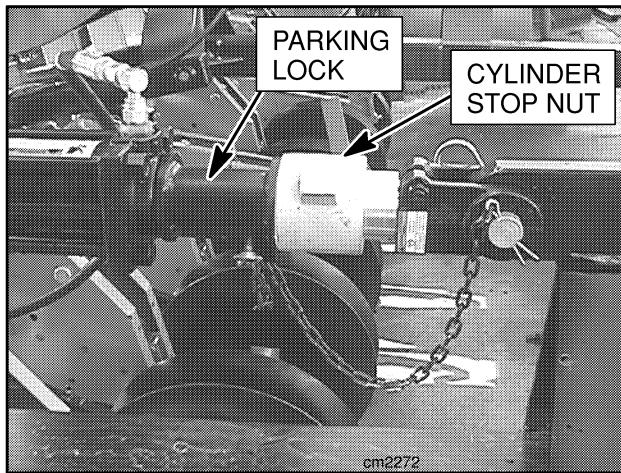

Figure 12. Lift Assist Parking Locks Installed

When storing folding cultivator, parking locks must be installed, lift assist wheels must be lowered to rest on the cylinder stops and front parking stands installed as described in **Removing Cultivator from Tractor**.

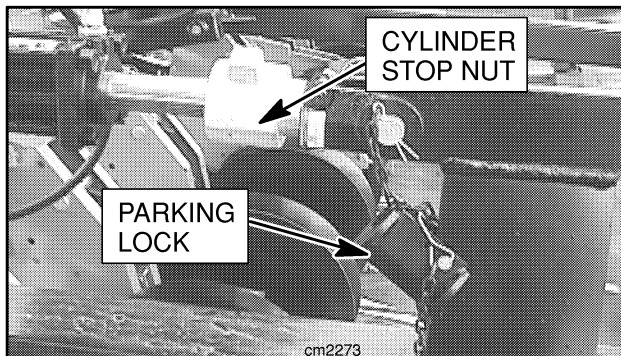

Figure 13. Lift Assist Parking Locks Stored

FIELD OPERATION

WARNING

■ A minimum 20% of tractor and equipment weight must be on tractor front wheels with attachments in transport position. Without this weight, tractor could tip over causing personal injury or death. The weight may be attained with a loader, front wheel weights, ballast in tires or front tractor weights. Weigh the tractor and equipment. Do not estimate.

IMPORTANT

■ Raise cultivator out of the ground when making sharp turns.

■ Do not back up with sweeps or tools in the ground.

Enter field and straddle rows in same direction of planter travel. Make sure no one is near cultivator when raising or lowering wings. Unfold into operating position. Lower cultivator and move forward approximately 20 feet.

Check shovel working depth. This is done by brushing worked soil aside to determine amount of ground penetration. Shovel depth is adjusted by raising or lowering the gauge wheel on each gang. Gangs behind tractor wheels are often adjusted deeper to loosen compacted soil.

If necessary, re-adjust tine placement for proper coverage.

If necessary, re-adjust upper 3-point link to provide equal ground penetration of front and rear shovels.

If necessary, reset the 3-point lever stop and adjust the support wheels after the working depth has been established to maintain operating position as shown in Figure 15.

Refer to “Adjusting,” page 20, for adjustment of individual attachments. Additional adjustment procedures for optional attachments are found in the Assembly section.

TRANSPORTING

When transporting the machine, review and follow these instructions:

Be sure all bystanders are clear of the machine.

Be sure that the machine is securely attached to the tractor and all retainer pins are installed.

Raise the machine.

Check the pressure in the tires. Be sure they are to their specified pressure.

Keep to the right and yield the right-of-way to allow faster traffic to pass. Drive on the road shoulder if permitted by law.

Do not allow riders.

Use pilot vehicles front and rear if required.

Never disengage tractor drivetrain and coast down hills. Always keep tractor in gear.

Never transport the machine faster than 10 mph (16 kph).

Know the transport height and width of your cultivator.

Stay away from overhead power lines. Electrocutation can occur without direct contact.

STORAGE

CAUTION

- Keep children and bystanders away from storage area.

At the end of the season, the machine should be thoroughly inspected and prepared for storage. Repair or replace any worn or damaged components to prevent any unnecessary down time at the beginning of the next season. Select a storage area that is dry, level and free of debris.

Clear the area of bystanders.

On solid level ground, lower cultivator to rest in a stable level position with parking stands properly positioned.

Stop engine, set parking brake, wait for all moving parts to stop and remove ignition key before dismounting.

Repair or replace damaged parts. Remove any entangled material.

Inspect all hydraulic hoses, lines, couplers and fittings. Tighten any loose fittings. Replace any hose that is badly cut, nicked, abraded or is separating from the crimped end of a fitting.

Lubricate all grease fittings. Make sure that all grease cavities have been filled with grease to remove any water residue from washing.

Touch up all paint nicks and scratches to prevent rusting.

Remove from tractor as described in **Removing Cultivator from Tractor**.

NOTE: Do not deflate tires.

Store the machine in an area away from human activity. Do not allow children to play on or around the stored machine.

ADJUSTING

Leveling Toolbar Wings (Figure 14)

Level wings to center toolbar using stop adjustment bolts.

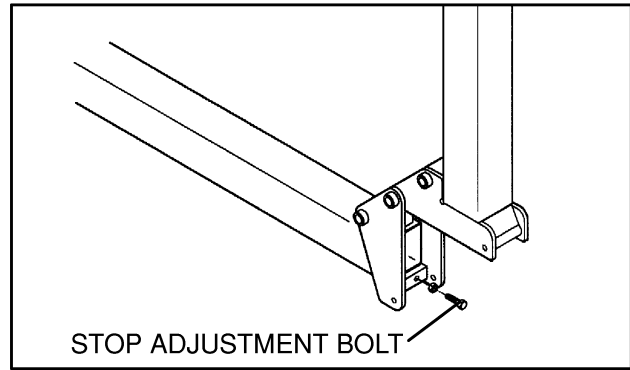

Figure 14. Toolbar Wings

Adjusting Gang (Figure 15)

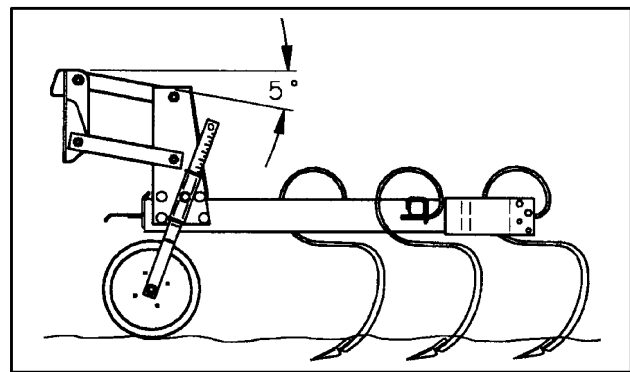

Figure 15. Gang Adjustment

Adjust tractor three-point hitch and frame gauge wheels so that cultivator linkage operates approximately 5 degrees from level as shown in Figure 15.

Set shovel working depth by adjusting gauge wheel. Loosen set screw on side of mounting plate, adjust to proper height and tighten set screw.

Support Wheels (Figure 16)

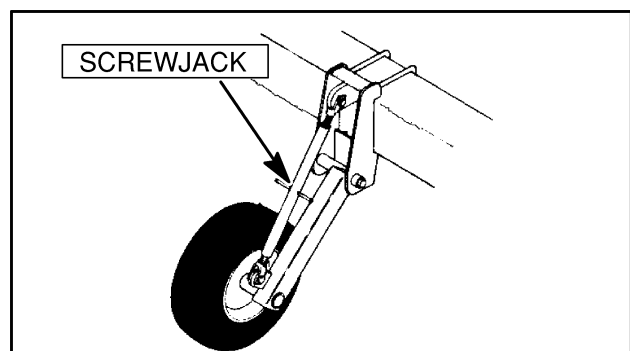

Figure 16. Support Wheels

CENTER FRAME SUPPORT WHEELS

Weight of the toolbar should be split between the tractor 3-point and the support wheels. Adjust support wheels mounted on rigid toolbars or on center section of folding toolbars to provide level operation of the toolbar. Use field conditions and desired cultivator performance to set support wheel operating height.

Adjust adjustable support wheels by shortening the screwjack to lower the tool bar or lengthening the screwjack to raise the tool bar.

WING SUPPORT WHEELS

The adjustable support wheels, mounted on the wings of folding toolbars, should be positioned and adjusted to maintain a proper working height at the wing's outer end. If center frame operating position is changed, it will be necessary to re-adjust the wing support wheels.

Adjust adjustable support wheels by shortening the screwjack to lower the tool bar or lengthening the screwjack to raise the tool bar.

Adjustable Sweep Adapter (Figure 17)

Loosen bolts on side of sweep adapter. Loosen jam nut on back set screw. Adjust set screw until desired angle is reached. Tighten jam nut on set screw and side bolts.

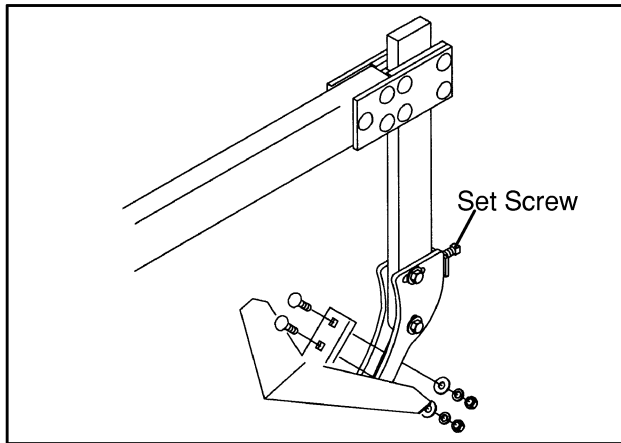

Figure 17. Sweep Adapter

Rear Trip Shank (Figure 18)

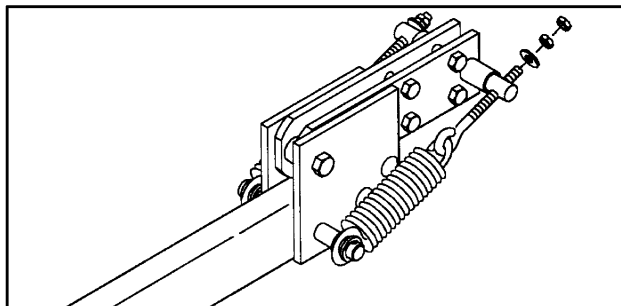

Figure 18. Rear Trip Shank

In hard packed field conditions the spring pressure may need to be increased. Tighten nut on eyebolts; try to keep even pressure on both springs.

Adjusting Coulters (Figure 19)

Loosen bolt through center of disc, loosen nuts on adjustment tab and adjust angle. Tighten all hardware.

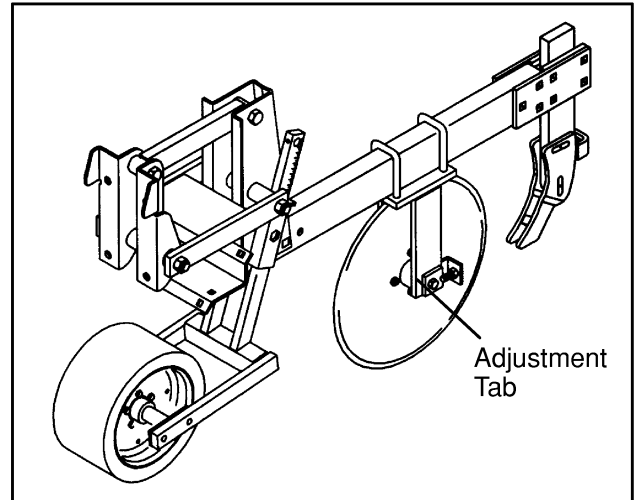

Figure 19. Coulters Disc (2065)

Front Stabilizer Coulters (Figure 20)

Stabilizer coulters should be adjusted to no more than 3 inches of ground penetration. Adjust pressure using eyebolt on spring.

Steering adjustment may be adjusted by loosening bolts on center of coulters disc and adjusting adjustment tab.

After proper adjustment, tighten all hardware.

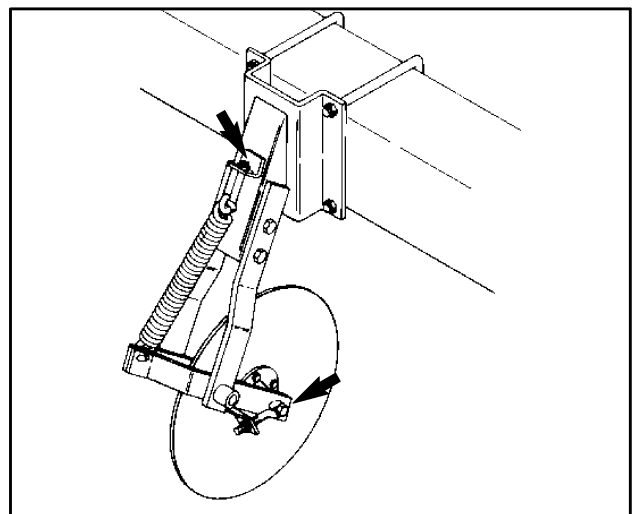

Figure 20. Front Stabilizer Coulters

Rear Stabilizer (Figure 21)

Stabilizer coulters should be adjusted to no more than 3 inches of ground penetration. Adjust penetration by adjusting screw jack to desired depth.

Horizontal and vertical adjustments may be obtained by adjusting set screws on mounting frame. After adjusting, be sure to tighten jam nuts on set screws.

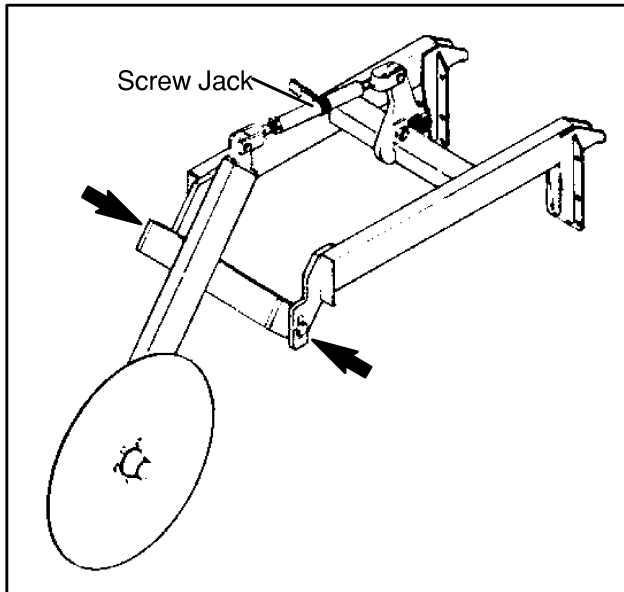

Figure 21. Rear Stabilizer

Slide Mount Tunnel Shields (Figure 22)

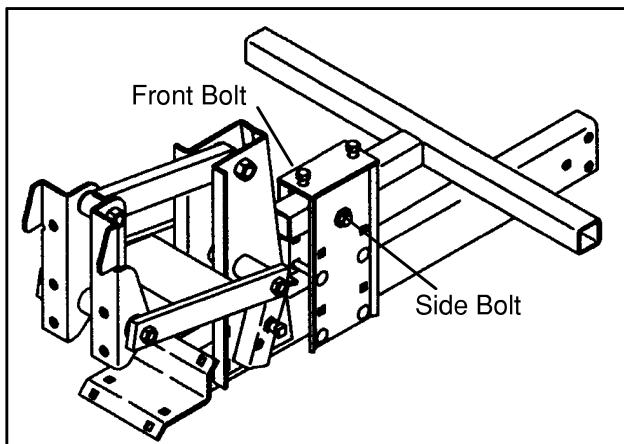

Figure 22. Slide Mount Tunnel Shields

Level the shields by loosening side bolt on slide mount bracket. Adjust shield front bolt on top side. After shields are level, snug rear bolt and tighten side bolt. Be sure to tighten jam nuts.

Dual Discs (Figure 23)

Adjust width of discs by loosening bolts and jam nuts on top of disc clamp. Slide discs on rails until desired width is reached. Tighten bolts and jam nuts.

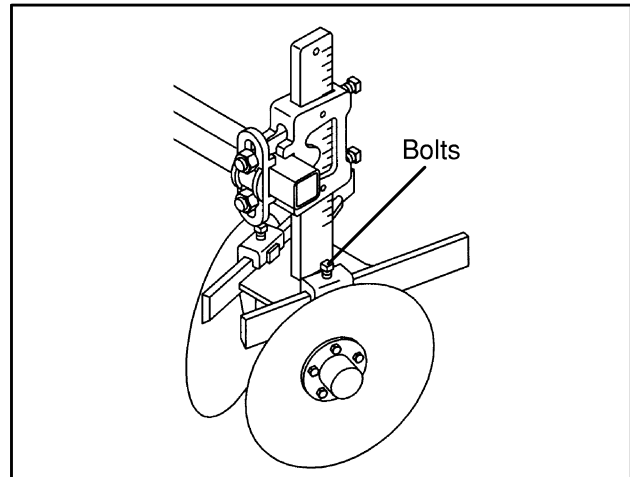

Figure 23. Dual Discs

Sweeps (Figure 24)

Adjust pitch of sweep by using different hole location on the tine (straight edge tine). For adjustment of additional attachments, refer to "Assembly" section.

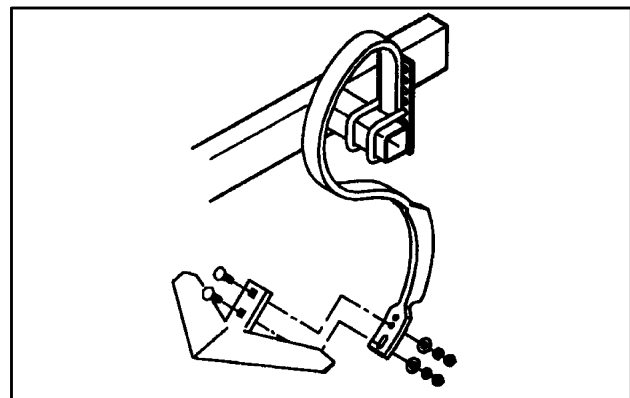

Figure 24. Sweeps

SERVICE

Safety is a primary concern in the design and manufacture of our products. Unfortunately, our efforts to provide safe equipment can be wiped out by an operator's single careless act.

In addition to the design and configuration of equipment, hazard control and accident prevention are dependent upon the awareness, concern, judgement, and proper training of personnel involved in the operation, transport, maintenance and storage of equipment.

It has been said "The best safety device is an informed, careful operator." We ask you to be that kind of operator.

The information in this section is written for operators who possess basic mechanical skills. Should you need help, your dealer has trained service technicians available. For your protection, read and follow all safety information in this manual.

CAUTION

- If you do not understand any part of this manual and need assistance, see your dealer.
- Always wear relatively tight and belted clothing to avoid entanglement in moving parts. Wear sturdy, rough-soled work shoes and protective equipment for eyes, hair, hands, hearing and head.

WARNING

- Know your controls and how to stop engine and attachment quickly in an emergency.
- Keep hands and body away from pressurized lines. Use paper or cardboard, not body parts to check for leaks. Wear safety goggles. Hydraulic fluid under pressure can easily penetrate skin and will cause serious injury or death.
- Make sure that all operating and service personnel know that if hydraulic fluid penetrates skin, it must be surgically removed as soon as possible by a doctor familiar with this form of injury or gangrene, serious injury, or death will result. CONTACT A PHYSICIAN IMMEDIATELY IF FLUID ENTERS SKIN OR EYES. DO NOT DELAY.
- Never allow children or untrained persons to operate equipment.

WARNING

- Do not allow bystanders in the area when operating, attaching, removing, assembling, or servicing equipment.
- Before dismounting tractor or performing any service or maintenance, disengage power to implement, lower the 3-point hitch and all raised components to the ground, operate valve levers to release any hydraulic pressure, set parking brake, stop engine, remove key, and unfasten seat belt.
- Before servicing, unfold completely to operating position. Do not service with wings in any other position.
- Never go underneath equipment lowered to the ground or raised. Never place any part of the body underneath equipment or between moveable parts even when the engine has been turned off. Hydraulic system leak down, hydraulic system failures, mechanical failures or movement of control levers can cause equipment to drop or rotate unexpectedly and cause severe injury or death.
 - Service work does not require going underneath.
 - Read operator's manual for service instructions or have done by a qualified dealer.

GREASING

Use an SAE multi-purpose high temperature grease with extreme pressure (EP) performance. Also acceptable is an SAE multi-purpose lithium based grease.

1. Use a hand-held grease gun for all greasing.
2. Wipe grease fitting with a clean cloth before greasing, to avoid injecting dirt and grit.
3. Replace and repair broken fittings immediately.
4. If fittings will not take grease, remove and clean thoroughly. Also clean lubricant passageway. Replace fitting if necessary.

Storing Lubricants

Your machine can operate at top efficiency only if clean lubricants are used. Use clean containers to handle all lubricants. Store them in an area protected from dust, moisture and other contaminants.

SERVICING INTERVALS

The period recommended is based on normal operating conditions. Severe or unusual conditions may require more frequent lubrication.

10 HOURS

Lubricate 180 degree folding toolbar (Figure 25).

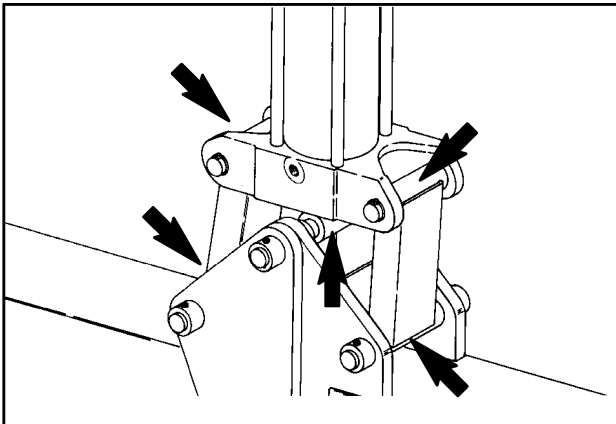

Figure 25. 180 Degree Folding Toolbar

Lubricate rear stabilizer coupler hub (Figure 26). Check air pressure in all pneumatic tires. Pressure should be 28 to 32 psi.

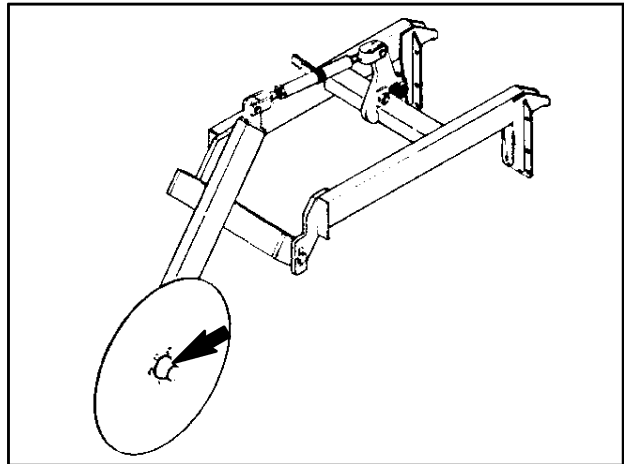

Figure 26. Rear Stabilizer Coupler

25 HOURS

Lubricate lift assist (light-duty) (Figure 27).

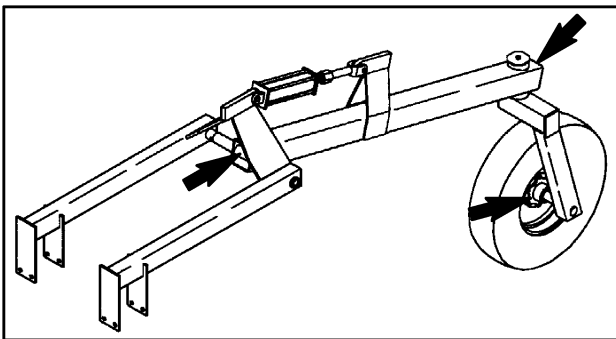

Figure 27. Lift Assist (Light-Duty)

Lubricate lift assist (heavy-duty) (Figure 28).

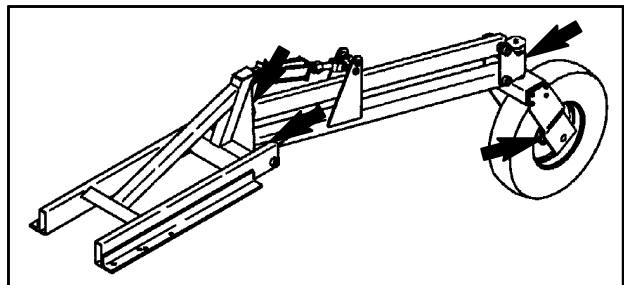

Figure 28. Lift Assist (Heavy-Duty)

ANNUALLY

Repack all wheel bearings.

NOTES

ASSEMBLY

DEALER SET-UP INSTRUCTIONS

Assembly of this cultivator is the responsibility of the Alloway dealer. The cultivator should be delivered to the owner completely assembled, lubricated and adjusted for normal conditions.

Set up cultivator as received from the factory with these instructions. Complete check lists on page 26 when it is set up.

Cultivators are shipped disassembled. When you receive shipment, examine the unit carefully for any hidden damage during shipment. Check and compare the parts, bundles and cartons to the packing list to identify any shortages before assembly starts. If any parts shortages are noted, contact Alloway immediately.

Select an assembly location that is clean, and level with a firm dry surface. The area must not have any overhead power lines or obstructions and must be large enough to safely work around and accommodate the machine when fully assembled.

Remove cultivator from carton. Open parts box and lay parts out to make location easy. Refer to parts lists and exploded view drawings in this manual.

Recommended torque values for hardware are given on page 11.

CAUTION

■ Always wear relatively tight and belted clothing to avoid entanglement in moving parts. Wear sturdy, rough-soled work shoes and protective equipment for eyes, hair, hands, hearing and head.

WARNING

■ Keep hands and body away from pressurized lines. Use paper or cardboard, not body parts to check for leaks. Wear safety goggles. Hydraulic fluid under pressure can easily penetrate skin and will cause serious injury or death.

■ Make sure that all operating and service personnel know that if hydraulic fluid penetrates skin, it must be surgically removed as soon as possible by a doctor familiar with this form of injury or gangrene, serious injury, or death will result. CONTACT A PHYSICIAN IMMEDIATELY IF FLUID ENTERS SKIN OR EYES. DO NOT DELAY.

■ Air in hydraulic systems can cause erratic operation and allows loads or equipment components to drop unexpectedly. Before putting into service or allowing anyone to approach the equipment, purge any air in the system by operating all

hydraulic functions several times after connecting equipment, connecting hoses, or doing any hydraulic maintenance.

WARNING

- Before folding or unfolding cultivator:
 - Make sure you have adequate clearance on each side and overhead.
 - Make sure wing cylinder restrictor fittings are properly installed.
 - Make sure wing-mounted gauge wheels and guide coulters will not contact tractor cab or tires.
- Never allow children or untrained persons to operate equipment.
- Do not allow bystanders in the area when operating, attaching, removing, assembling, or servicing equipment.
- Before dismounting tractor or performing any service or maintenance, disengage power to implement, lower the 3-point hitch and all raised components to the ground, operate valve levers to release any hydraulic pressure, set parking brake, stop engine, remove key, and unfasten seat belt.
- Do not handle blades with bare hands. Careless or improper handling may result in serious injury.

PRE-DELIVERY CHECK LIST

(DEALER'S RESPONSIBILITY)

Inspect the equipment thoroughly after assembly to ensure it is set up properly before delivering it to the customer.

The following check lists are a reminder of points to inspect. Check off each item as it is found satisfactory or after proper adjustment is made.

- ___ Check that all safety decals are installed and in good condition. Replace if damaged.
- ___ Properly attach implement to tractor and make all necessary adjustments.
- ___ Check all bolts to be sure they are tight.
- ___ Check wheel bolts for proper torque.
- ___ Check that all cotter pins and safety pins are properly installed. Replace if damaged.

___ Check and grease all lubrication points as identified in “Service, lubrication information.”

___ Check that hydraulic reservoir has been serviced and that hydraulic system and all functions have been operated through full cylinder stroke to purge air from system.

DELIVERY CHECK LIST

(DEALER’S RESPONSIBILITY)

___ Show customer how to make adjustments.

___ Instruct customer how to lubricate and explain importance of lubrication.

___ Point out the safety decals. Explain their meaning and the need to keep them in place and in good condition. Emphasize the increased safety hazards when instructions are not followed.

___ Present Operator’s Manual and request that customer and all operators read it before operating equipment. Point out the manual safety rules, explain their meanings and emphasize the increased safety hazards that exist when safety rules are not followed.

___ Explain to customer the potential crushing hazards of going underneath raised equipment. Instruct customer that service work does not require going underneath unit and never to do so.

___ Show customer the safe, proper procedures to be used when mounting, dismounting, and storing equipment.

___ For mounted units, add wheel weights, ballast in front tires, and/or front tractor weight to enhance front end stability. A minimum 20% of tractor and equipment gross weight must be on front tractor wheels. When adding weight to attain 20% of tractor and equipment weight on front tractor wheels, you must not exceed the ROPS weight certification. Weigh the tractor and equipment. Do not estimate!

___ Explain to customer that when equipment is transported on a road or highway, a Slow Moving Vehicle (SMV) sign should be used to provide adequate warning to operators of other vehicles.

___ Make customer aware of optional equipment available so that customer can make proper choices as required.

ORDER OF ASSEMBLY

It is suggested to completely assemble two rows of the cultivator including all options and accessories prior to assembling the entire cultivator. There are many variations in assembly all depending upon your application and conditions. Once you have completed the initial assembly of two rows and approve the configuration, then continue assembling balance of cultivator.

1. Mount 3-point hitch.
2. Fasten “Alloway” decal.
3. Assemble toolbar.
4. Mount linkages to toolbar.
5. Mount trees to linkages.
6. Mount gauge wheels to trees.
7. Mount front tubes (Optional).
8. Mount dual disc/dual knife (Optional).
9. Mount branches to trees.
10. Fasten rear tine brackets.
11. Fasten rear extensions (Optional).
12. Fasten sweeps or shovels to tines (Optional).
13. Attach tines.
14. Attach rear shanks.
15. Mount guide wheels and/or support wheels (Optional).
16. Fasten parking stand (Included with all King Guide Struts).
17. Mount shields (Optional).
18. Mount lift assist (Optional).
19. Fasten remaining decals.
20. Tighten all bolts to specifications in Bolt Torque Chart.
21. Check that all tire pressures are 28–32 psi.

Decal Installation Procedure

Be sure that the installation area is clean and dry.

Decide on the exact position before you remove the backing paper.

Remove the smallest portion of the split backing paper.

Align the decal over the specified area and carefully press the small portion with the exposed sticky backing in place.

Slowly peel back the remaining paper and carefully smooth the remaining portion of the decal in place.

Small air pockets can be pierced with a pin and smoothed out using the piece of decal backing paper.

Decal Locations (Figure 29)

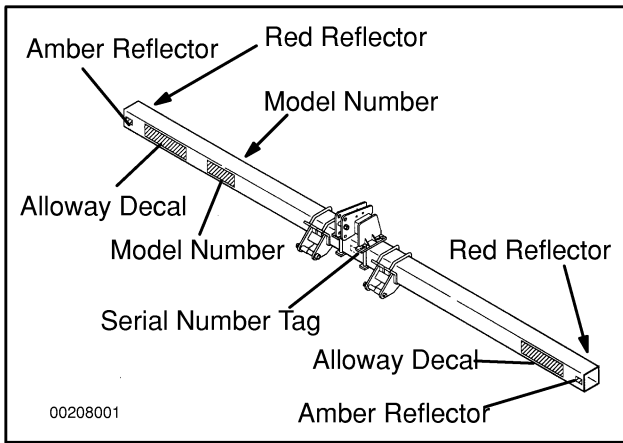

Figure 29. Decal Location

To avoid decals from interfering with cultivator components, all decals other than the “Alloway” decal can be applied after cultivator is assembled. On row spacings 36” and above, even the “Alloway” decal can be applied after cultivator assembly.

Place amber reflectors on the front side of toolbar as close to each end as possible. Place red reflectors on the back side of toolbar as close to each end as possible.

Attach serial number tag to the front center of the toolbar using U-drive screws.

Attach “Alloway” decals to the front side of toolbar. Place them towards the end of the beams or on the wings of folding beams.

Attach model number decals on front and back side of toolbar. Place them towards the end of the toolbar or on the wings of folding toolbars.

Fasten the tube caps to the end of the toolbars using adhesive provided.

MOUNTING 3-POINT HITCHES

Support the toolbar on suitable stands. Determine toolbar type, Figure 31, and locate center point of toolbar. Mark center point for reference during assembly.

Mount the upper hitch mast supplied with cultivator that matches the toolbar type.

Four Piece Upper Mast for F & FR Bars, 8 Row and Smaller

Install upper mast using backstraps, 7/8 NC x 10” hex bolts, lockwashers and nuts. Fasten the 1-1/4” OD bushings between the plates using 1 x 5” hex bolts, lockwashers and nuts. See Figure 32 and Figure 33 for the correct bushing location to fit the hitch that will be used.

Be sure upper mast is centered on the toolbar.

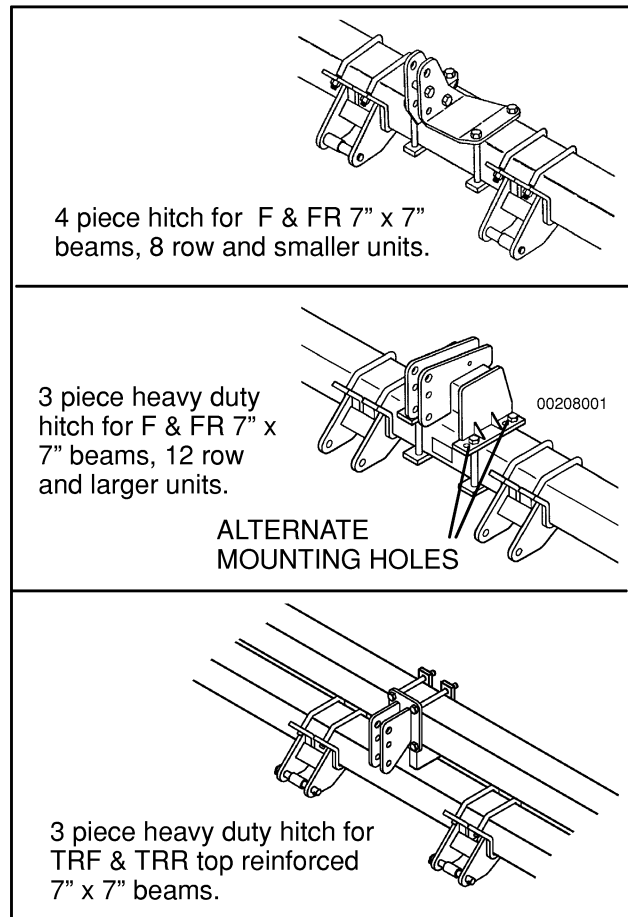

Figure 30. Upper Hitch Masts

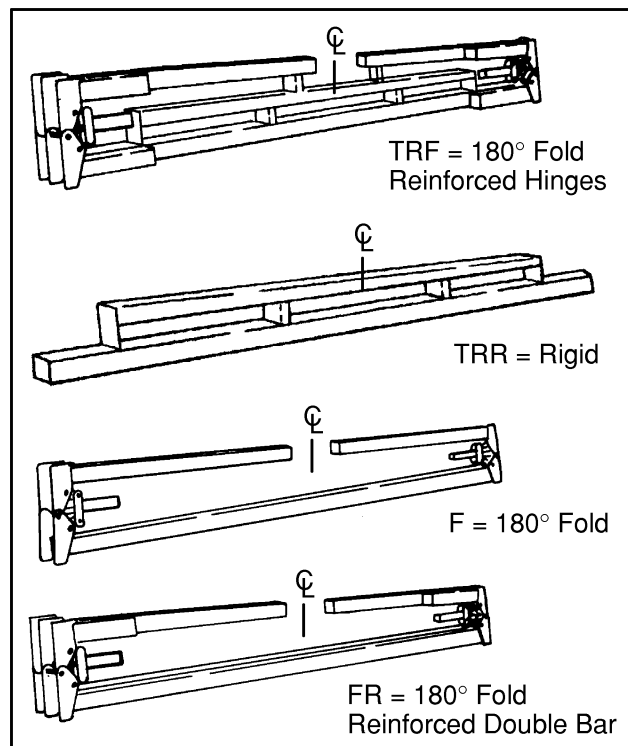

Figure 31. Toolbar Identification

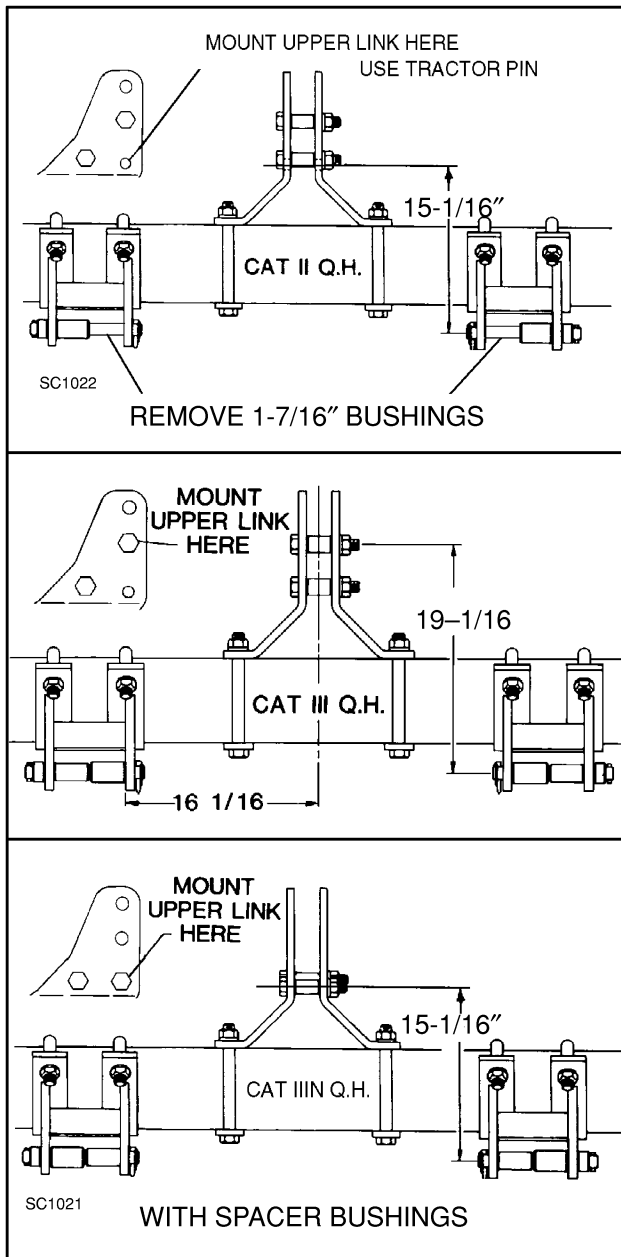

Figure 32. Quick Hitches

Three Piece Heavy-Duty Mast for F & FR Bars, 12 Row and Larger

Install upper mast using backstraps, 7/8 NC x 10" hex bolts, lockwashers and nuts. Fasten the 1-1/4" OD bushings between the plates using 1 x 5" hex bolts, lockwashers and nuts. See Figure 32 and Figure 33 for the correct bushing location to fit the hitch that will be used. Be sure upper mast is centered on the toolbar.

NOTE: The upper mast may be attached using the front mounting holes when additional leveling adjustment is needed. Tractors with 46" tires and FWA may require this alternate mounting position.

Three Piece Heavy-Duty Mast for TRR & TRF Bars

Install upper mast using backstraps, 7/8 NC x 10" hex bolts, lockwashers and nuts. Fasten the 1-1/4" OD bushings between the plates using 1 x 5" hex bolts, lockwashers and nuts. See Figure 32 and Figure 33 for the correct bushing location to fit the hitch that will be used. Be sure upper mast is centered on the toolbar.

NOTE: On TRF and FR toolbars, the short side of wings must be on tractor side of toolbar.

IMPORTANT

■ Do not use the upper mast when using lift assist without accumulator.

Fasten the two lower 3-point brackets to the toolbar using 7/8" A-bolts, lockwashers and nuts. Position lower 3-point brackets and spacers to match tractor hitch, Figure 32 and Figure 33.

Mount spacer to lower 3-point brackets using 1-1/8" OD x 9-5/16" pins and 7/16 x 2" snap ring.

Do not tighten bolts until entire cultivator is assembled. Hitch mounting bolts may need to be remounted between U-bolts as on 20"-22" row spacing.

Row spacing or optional equipment may prevent lower hitch bracket installation at the 16-1/16" dimension. CAT II applications can be installed at 13-1/16" and CAT III applications at 19-1/16". Move the lower hitch bushings to the proper location to engage the hitch.

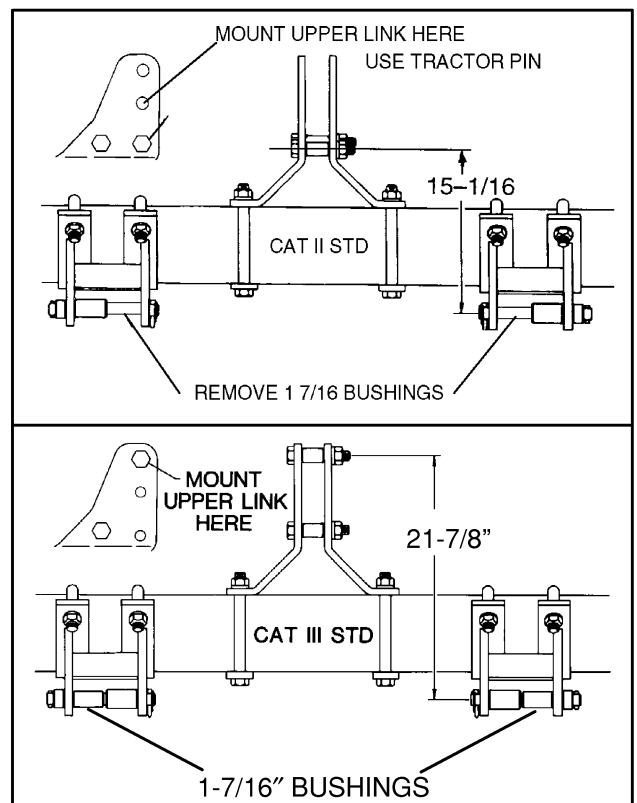

Figure 33. Standard Hitches

MOUNTING WINGS

On toolbars with 180 degree folding wings, assemble the cylinder yoke assembly at the same time the wings are mounted. Use longest pins on 7 x 7" toolbars. The ports on the cylinder should face toward the tractor side of the cultivator. Secure the hinge pins with 5/16 x 2-1/2" bolts and locknuts. Assemble 3/4" jam nuts onto the 3/4" x 2-1/2" bolts and turn them into the hinge plates located at the underside of the hinge. The head of the bolt faces wings.

Note: On double toolbars, short side of wings must be on tractor side of toolbar or bolts used to level wings will not be in proper placement.

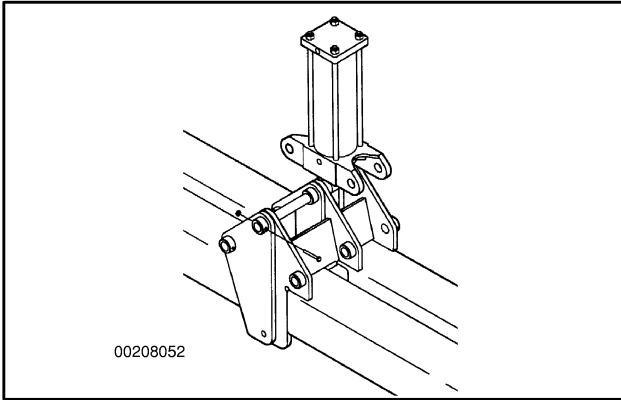

Figure 34. Mounting Wings

Assemble grease zerks in cylinder linkage bars. Mount the linkage bars to the center section using longest pins. Mount the linkage bars to the wings using medium length pins. The grease zerks should point outward from the hinge. Secure the linkage bar pins with 5/16" x 2-1/2" bolts and locknuts.

Assemble the linkage bars to the cylinder casting using welded head pins and snap ring pins as shown in Figure 35. The snap ring pins go through the pin on the tractor side of the cylinder.

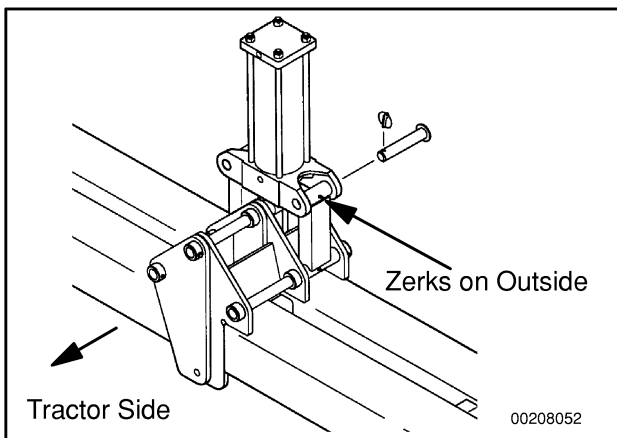

Figure 35. Cylinder Linkage Bars

MOUNTING HYDRAULICS

WARNING

■ **Air in hydraulic systems can cause erratic operation and allows loads or equipment components to drop unexpectedly. Before putting into service or allowing anyone to approach the equipment, purge any air in the system by operating all hydraulic functions several times after connecting equipment, connecting hoses, or doing any hydraulic maintenance.**

■ **Route hydraulic hoses carefully to prevent damage. Hoses must not be twisted, bent sharply, kinked, frayed, pinched, or come into contact with any moving parts. Operate moveable components through full operational range to check clearances. Replace any damaged hose immediately.**

Note: Use thread sealant on all NPT hydraulic fittings.

Fasten the 3/4" MORB x 1/2" JIC restrictors to the cylinders. Then attach the -6 JIC swivel elbows to the restrictors. They should point downwards and toward the center of the cultivator.

Fasten the long hoses to the upper ports on cylinders and medium hoses to the lower ports on cylinders.

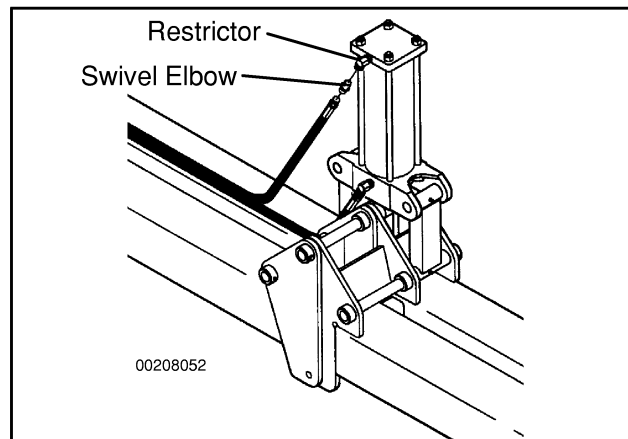

Figure 36. Fittings

Run the hoses to the center of toolbar and fasten the two long hoses and two shorter hoses together using -6 JIC tees. Fasten two 60" hoses to the tees and run them toward the tractor.

NOTE: If you prefer to lift wings separately you need to purchase (two) 60" hoses and four elbows and replace the tees with elbows.

Fasten the hoses to toolbar using the plastic hose clamps. Do this after cultivator is completely assembled.

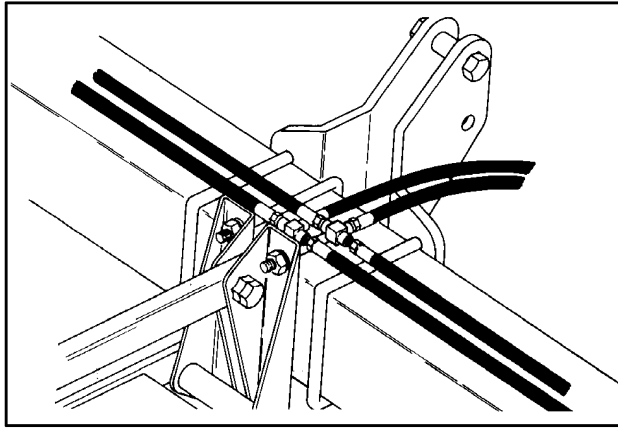

Figure 37. Hoses

Fasten the wing rests to the center section using 5/8" U-bolts, nuts and lockwashers (not required on 24 row 22" machines). Locate them by measuring from hinge pin other directions to assure there is no interference with gang assemblies when folded. Do not tighten until entire cultivator is assembled as they may require moving to miss other components bolted to center toolbar or wings.

Install hydraulic tips and attach 3-point hitch to front of toolbar. Attach to tractor and slowly fold and unfold, then make final adjustments.

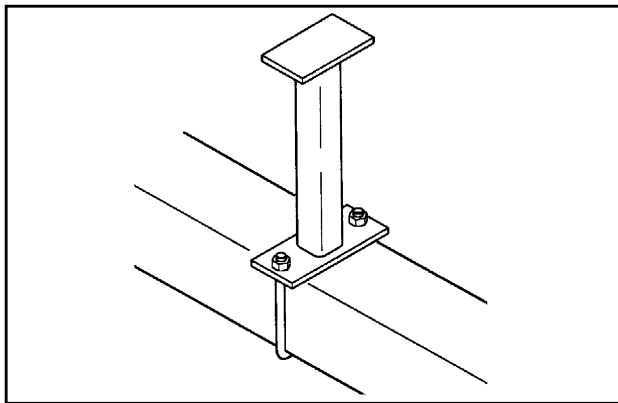

Figure 38. Wing Rest

When first charging the hydraulic cylinders on folding toolbars, you must slightly raise (1 foot) and unfold the wings several times to ensure that the hydraulic cylinders are completely filled with oil. Failure to do this will cause damage to the cultivator and possible personal injury as the wings will "free fall" into the transport position. Stay clear of folding toolbars when folding.

Level wings to the center toolbar using 3/4 x 2-1/2" hex bolts and jam nuts. These may require readjusting after final assembly of cultivator.

See decal location section for decal locations.

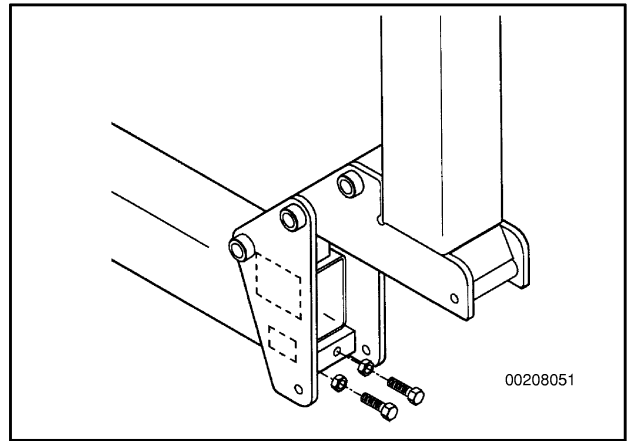

Figure 39. Leveling Wings

Mounting Linkages (Figure 40)

Locate the center of the toolbar and mark it. Mark off the row spacings on both sides of the center mark.

Example 1 – on even row units (8 or 12 rows) if the cultivator is for 30" rows, mark off every 30" on both sides of center mark.

Example 2 – on odd row units (9 rows) if the cultivator is for 30" rows, mark off 15" on both sides of center mark and then every 30" (there is no gang on center of toolbar).

Center the linkage assemblies over the marks made on the toolbar and fasten them using 5/8" U-bolts and serrated flanged nuts. On 2065 cultivators, fasten plate weldment in front of linkage and tighten set screws on bottom.

Note: On some vertical folding beams, the ear on the linkage closest to the hinge plate may have to be sawed or torch off. On 20"-22" row spacing cultivators, the U-bolt on linkage closest to lower 3-point goes through lower 3-point bracket.

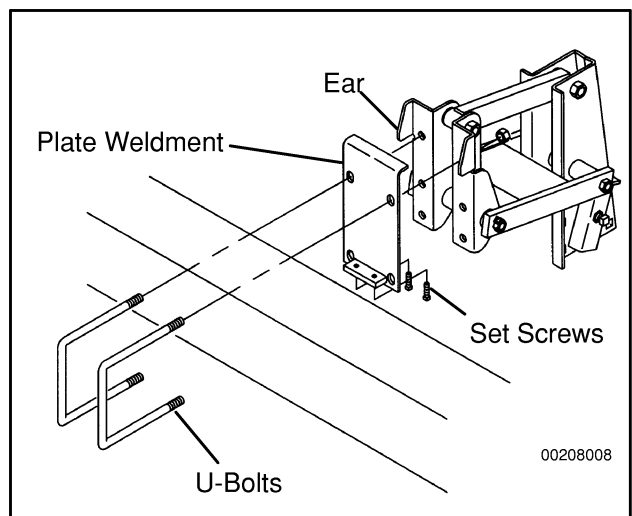

Figure 40. Linkage

Mounting Trees to Linkage (Figure 41)

Mount the tree to the linkage using four 5/8 x 3-1/2" carriage bolts and serrated flange nuts. The bolts go over the top of tree and through the holes in the tree. Be sure front tube clamp faces up as shown. On models 2130, 2040 and 2065, Carriage bolts must go through gauge arm pocket. On model 2065, do not tighten until yoke gauge wheel arm mounts are installed.

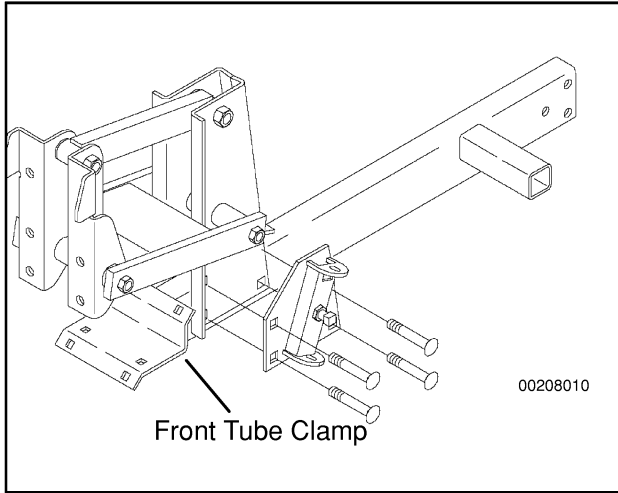

Figure 41. Tree

Mount the wheel assembly to the gauge wheel arm using 3/8 x 3/4" square head set screw and jam nut. The set screw bottoms out in groove in axle.

Position the gauge wheel arm assembly into the pocket on the linkage assembly and fasten with 5/8" square head set screw, be sure all the wheels are set at equal depths using the marks on the gauge arms. A typical initial setting is with four marks exposed above the mounting pocket.

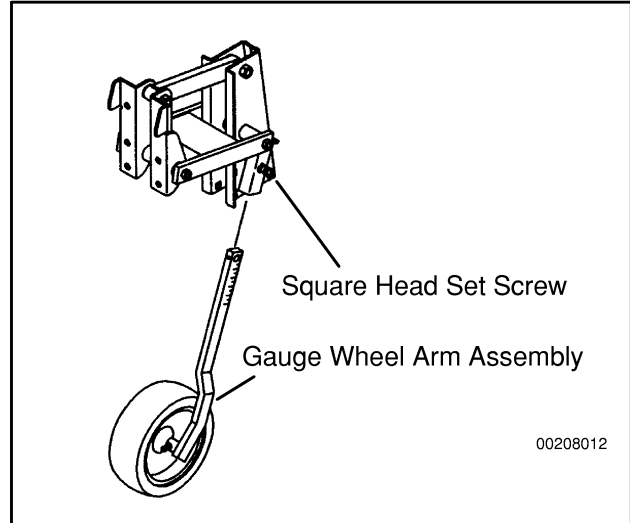

Figure 43. Mounting Gauge Wheel Assembly

Mounting Gauge Wheels (Figure 42 & Figure 43)

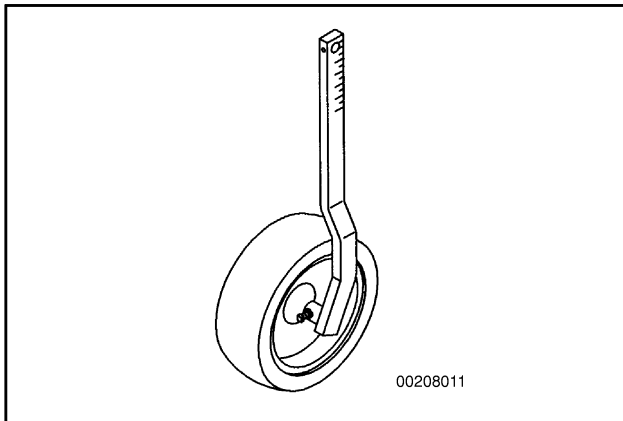

Figure 42. Gauge Arm & Wheel Assembly

Alloway supplies gauge wheel arms that extend the wheels forward to get them ahead of any possible dirt flow off other ground engaging tools. However, this is not possible behind the tractor tires when vertical guide wheels are utilized, therefore we also supply two straight gauge arms with each cultivator. If vertical guide wheels are not used, install the straight gauge arms on the end gangs of cultivator where potential dirt flow into gauge wheels is minimized.

YOKE STYLE GAUGE ARM – MODEL 2065 (Figure 44 – Figure 47)

Fasten bushing plates to both sides of gauge wheel assemblies using 3/8 x 3/4" square head set screws and jam nuts.

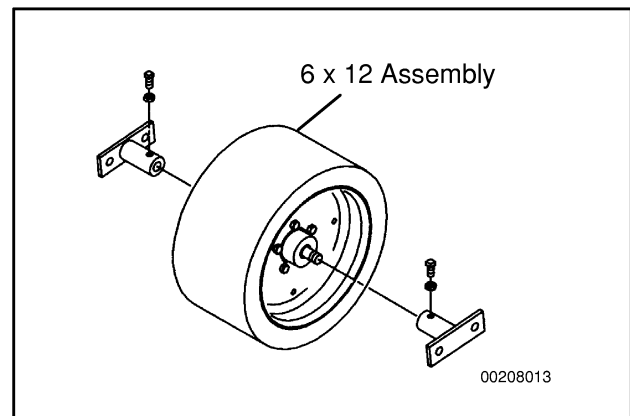

Figure 44. Bushing Plates

Mount the bushing plates to the gauge arm(s) using four 1/2 x 1-1/2 hex bolts and serrated flanged nuts.

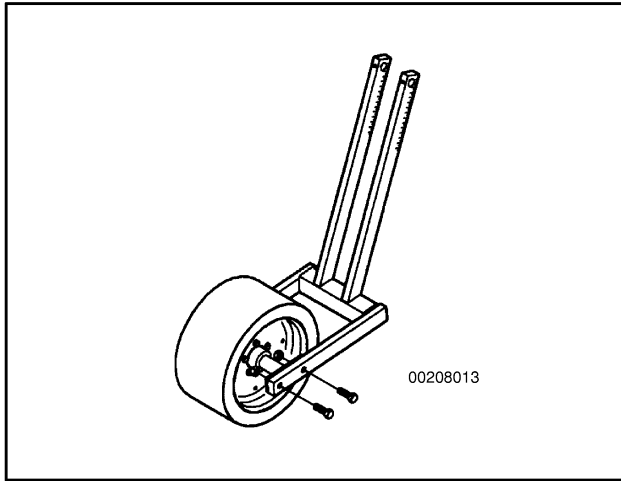

Figure 45. Wheel to Gauge Arm

Loosen the tree bolts and mount a gauge arm pocket to the linkage assembly using the carriage bolts and serrated flanged nuts that mount the trees.

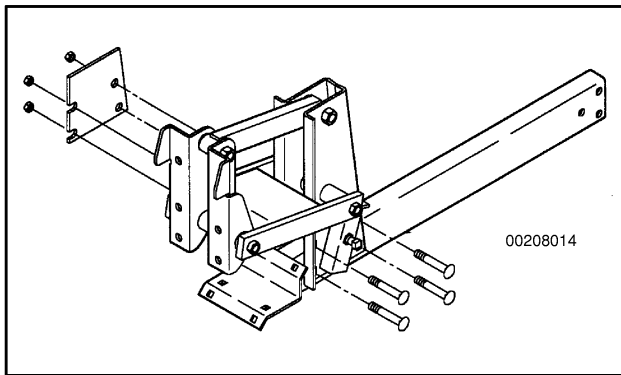

Figure 46. Gauge Arm Pocket

Slide the gauge arm assembly into the pockets on both sides of the linkage and mount using 5/8" square head set screws on one side, pack plate and hex bolts on the other. Be sure all gauge wheels are at equal depths, check marks on gauge arm.

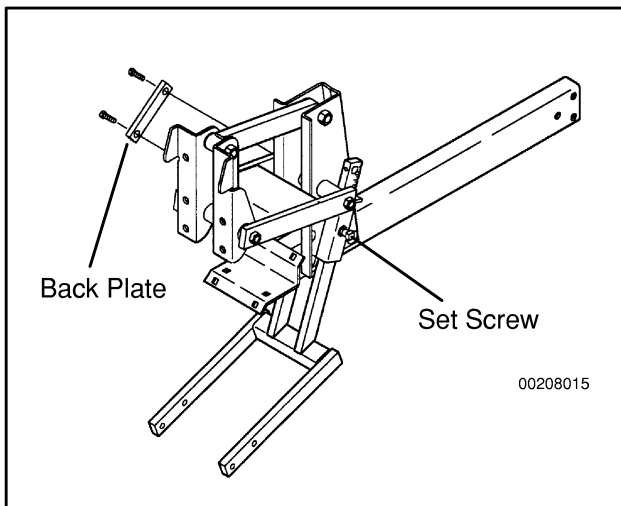

Figure 47. Gauge Arm Assembly

YOKE STYLE GAUGE ARM – MODEL 3030
(Figure 48 & Figure 49)

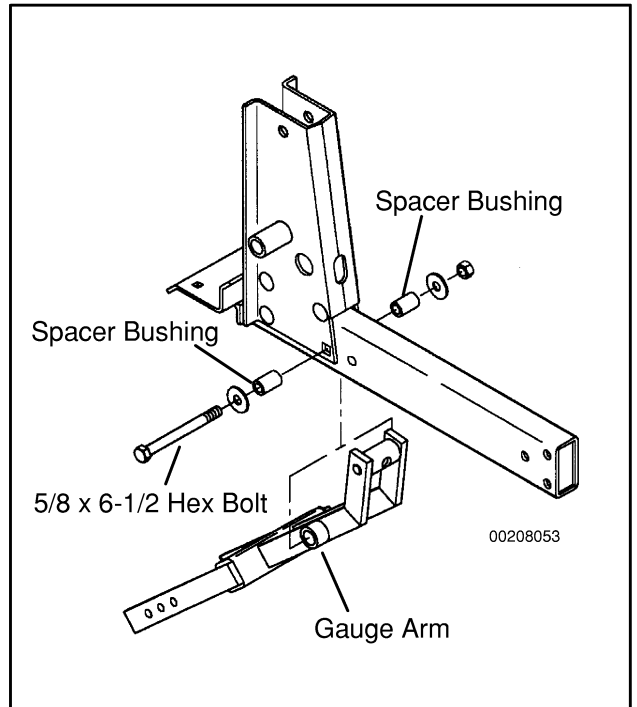

Figure 48. Mounting Gauge Arm - Model 3030

Fasten gauge wheel assembly to gauge arm as shown in Figure 45.

Slide spacer bushing into gauge arm and fasten to tree assembly using 5/8 x 6-1/2" hex bolt, flat washers and locknuts.

Slide bolt through trunion on gauge arm and flat washer, fasten using roll pin. Place trunion through holes in upright and thread bolt into trunion. Place plastic rod into end of trunion and secure with set screw.

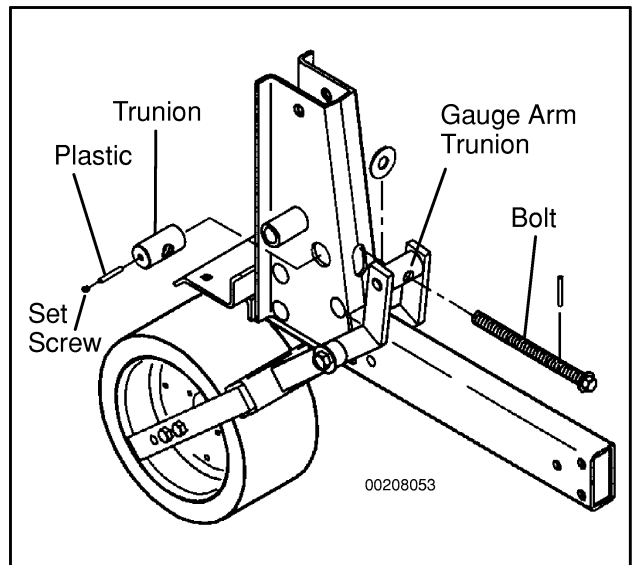

Figure 49. Mounting Gauge Arm - Model 3030

Adjustable Depth Control (Optional)

(Figure 50)

Place collar into gauge arm and fasten using a 1/4 x 1-1/4" roll pin.

Thread screw crank through collar. Place washer on each side of gauge arm pocket tab and fasten with 1/2 NF slotted hex nut and 1/8 x 3/4" roll pin.

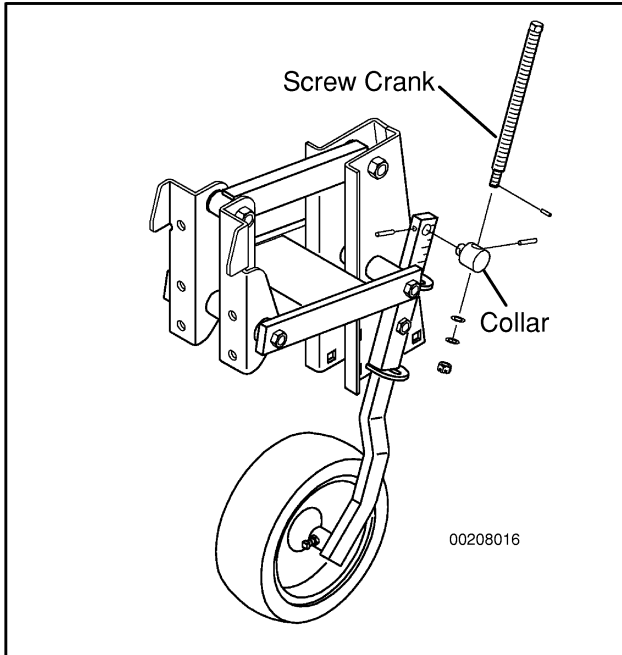

Figure 50. Adjustable Depth Control

King Guide Strut (Figure 51)

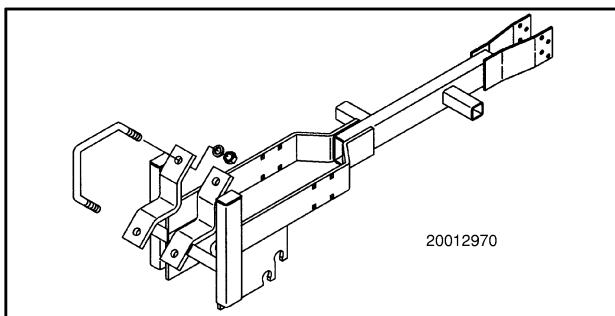

Figure 51. Mounting King Guide Strut

Fasten king guide strut to the toolbar using 7/8" A-bolts, lockwashers and hex nuts. Be sure strut is centered over guide marks.

Fasten hub assembly to wheel assembly using wheel nuts provided on hub assembly.

Loosen nuts on axle and slide wheel assembly into desired slot in frame. Tighten nuts. Typically in soft soil with deep wheel tracks use lower hole.

On 30" rows, fasten branch weldments to frame using 1/2 x 1-1/2" carriage bolts and serrated flanged nuts.

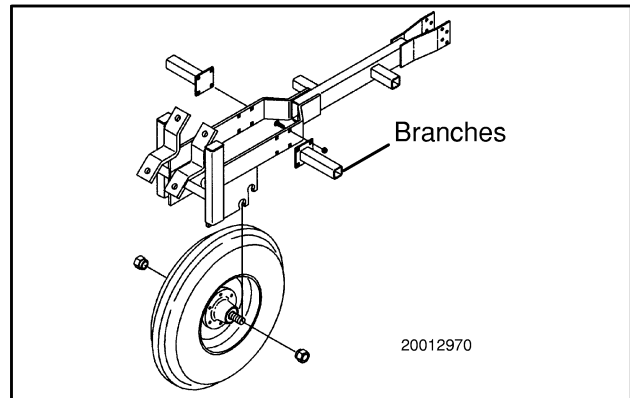

Figure 52. Mounting Branches

Mounting Branches

2040 CULTIVATOR

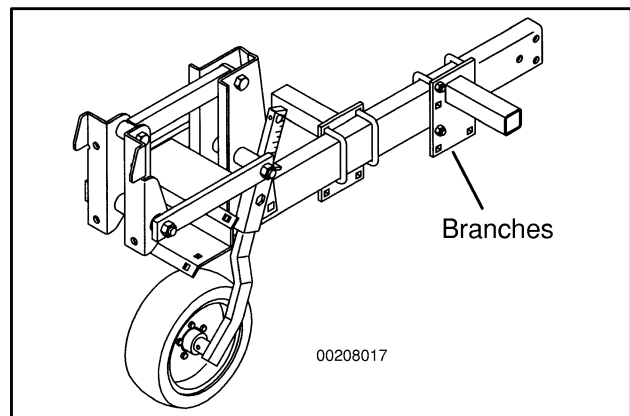

Figure 53. Tine Tree

On three tine trees, bolt the branches to the trees using four 1/2" U-bolts and serrated flange nuts. Space the branches equally along the tree for trash clearance. Note: The branches may be lowered or turned around to give different tine penetration. Initial set up is usually with all tine branches level with top of tree.

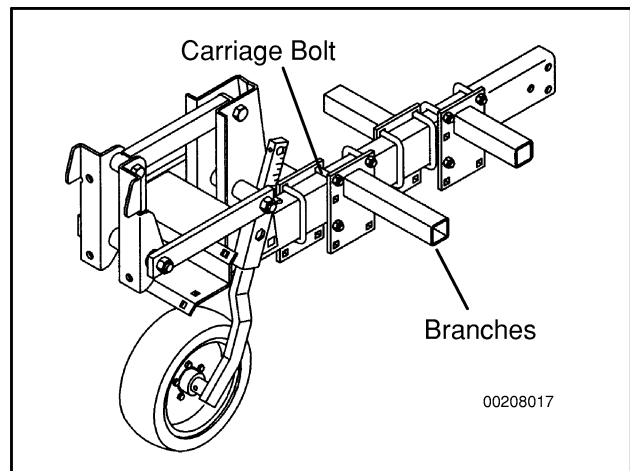

Figure 54. Tine Tree

On five tine trees, bolt the branches to the trees using six 1/2" U-bolts, two 1/2 x 3-1/2" carriage bolts and serrated flange nuts. The front branches will be bolted together with the carriage bolts. Space the branches equally along the tree for trash clearance. Note: the branches may be lowered or turned around to give different tine penetration. Initial set up is usually with all tine branches level with top of tree.

2065 CULTIVATOR

Fasten 17" long tubes to tree using 2" bracket on tree and 2-1/2" bracket on top of tube with two 1/2" U-bolts through the brackets. Space branches evenly between front and back of tree.

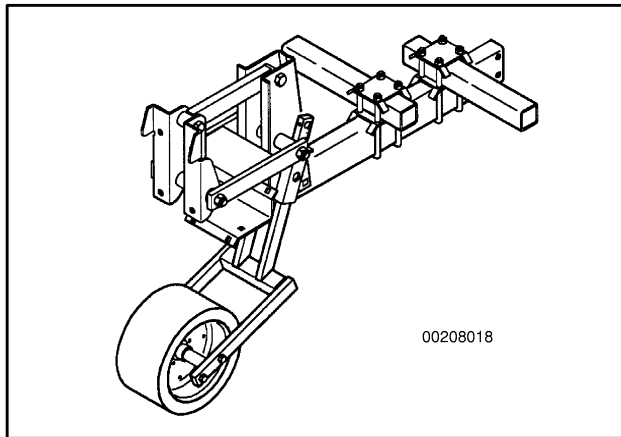

Figure 55. Model 2070 Branches

MOUNTING FRONT TUBES

Rigid Front Tubes

When mounting rigid front tubes, bolt the tube in place using a single tube clamp and 7/16 x 1-1/2" carriage bolts, lockwashers and hex nuts.

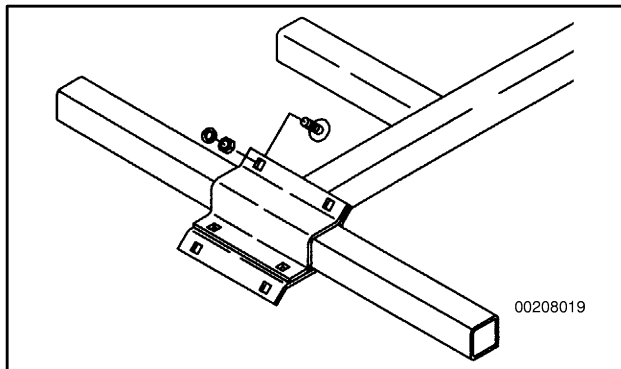

Figure 56. Rigid Front Tubes

Telescoping Front Tubes

When mounting telescoping front tubes, bolt the tube in place using a double tube clamp and 7/16 x 1-1/2" carriage bolts, lockwashers and hex nuts.

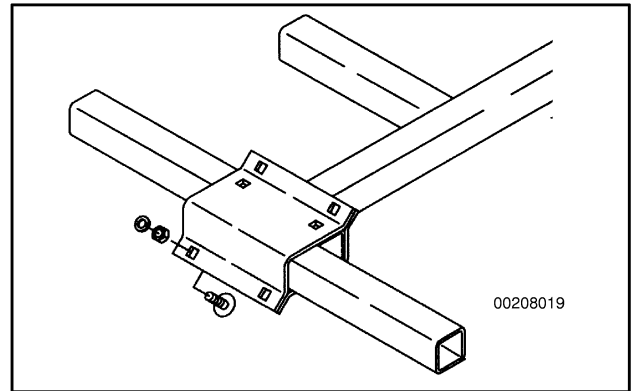

Figure 57. Telescoping Front Tubes

Offset Front Telescoping Tubes (2065 only)

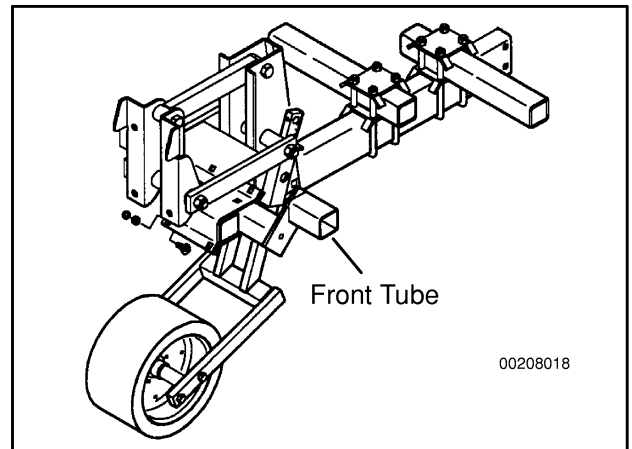

Figure 58. Offset Front Tubes

When mounting front tubes on 2065 cultivator, fasten the tubes in place using 7/16 x 1-1/2" carriage bolts and serrated flange nuts. Be sure the tubes are turned up and back as shown.

Mounting Rear Tine Bracket

ADJUSTABLE REAR TINE BRACKET

Fasten rear tine bracket to tree using 5/8 x 3-1/2" carriage bolts and serrated flange nuts. This bracket may be turned or lowered to adjust rear tine height.

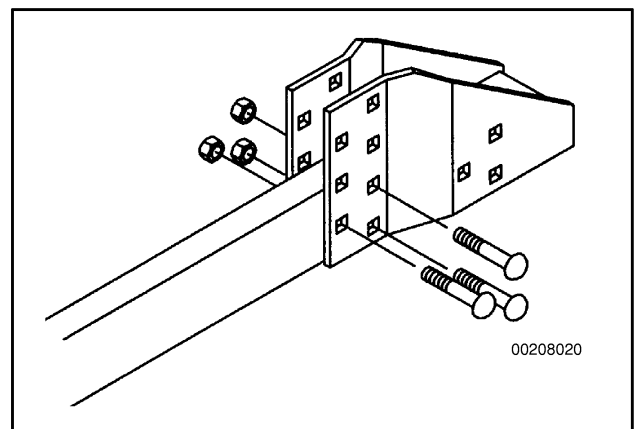

Figure 59. Adjustable Rear Tine Bracket

REAR TINE BRACKET (2130, KING GUIDE STRUT)

Fasten rear tube to tree using two 1/2 x 4-1/2" hex bolts and one 1/2 x 1" hex bolt and serrated flange nuts. This tube may be lowered or raised for different tine heights.

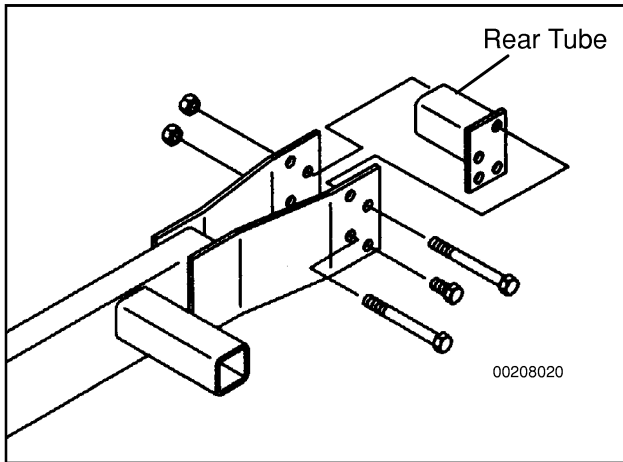

Figure 60. Rear Tine Bracket - Model 2130

PITCH BRACKET (2130)

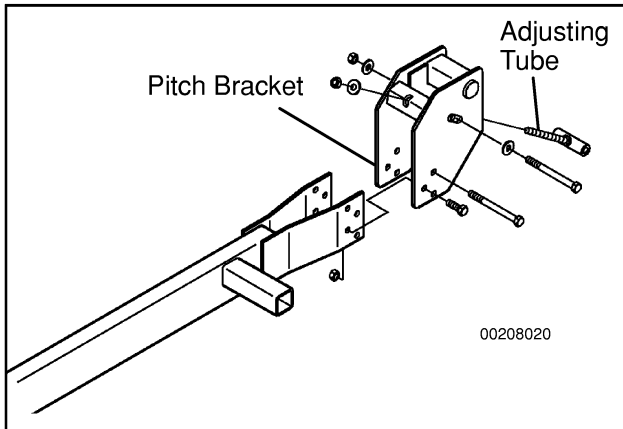

Figure 61. Pitch Bracket - Model 2130

Fasten rear bracket to tree using two 1/2 x 1" hex bolts, two 1/2 x 5" hex bolts and serrated flange nuts. Place adjusting tube into angle on pitch bracket and fasten using flat washer and locknut. Align adjusting screw, tube plates and slots in side plates and fasten using 1/2 x 5" hex bolt, two 1/2" flat washers and top locknut.

REAR TINE BRACKET (3030 AND 3030 KING GUIDE STRUT)

Fasten rear bracket to tree using three 5/8 x 3-1/2" carriage bolts and serrated flange nuts. Place trunion into rear tine bracket. Attach adjusting screw to trunion using washer and 1/4 x 2" roll pin. Slide plastic rod into end of lower trunion and secure with set screw. Thread adjusting screw into lower trunion and adjust until rear tube is level.

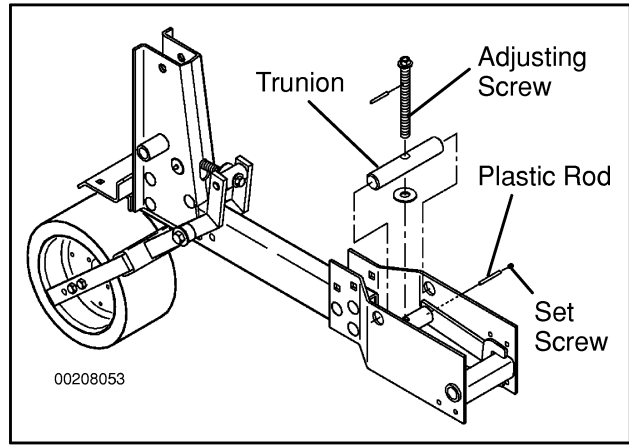

Figure 62. Rear Tine Bracket - Model 3030

Rear Extensions

MODEL 2040

Fasten rear extension to tree using 5/8 x 1-1/2" carriage bolts and serrated flange nuts.

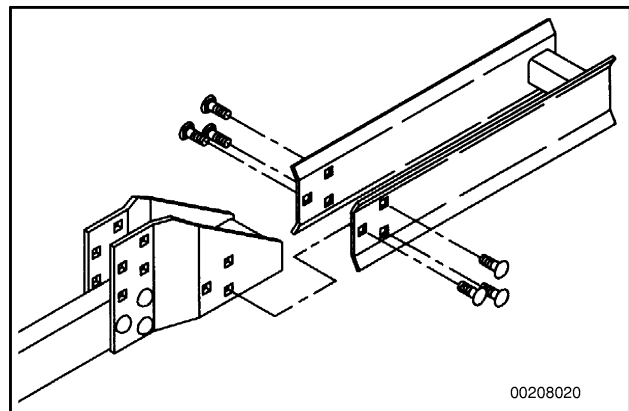

Figure 63. Rear Extension - Model 2030 & 2040

MODEL 2130

Fasten rear extension to (2130 cultivator) tree using two 1/2 x 1-1/4" hex bolts and two 1/2 x 5" hex bolts, lockwashers and hex nuts. You must keep cross tube in place.

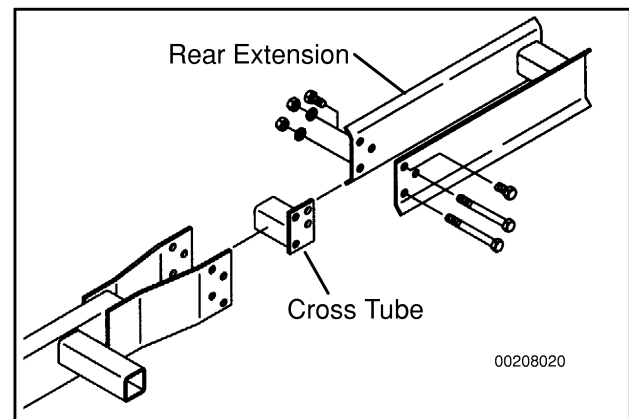

Figure 64. Rear Extension - Model 2130, King Guide

MODEL 3030

Fasten rear extension to (3030 cultivator) tree using four 3/8 x 1" hex bolts and serrated flanged nuts. Bolts must be mounted from inside of rear bracket pointing outward.

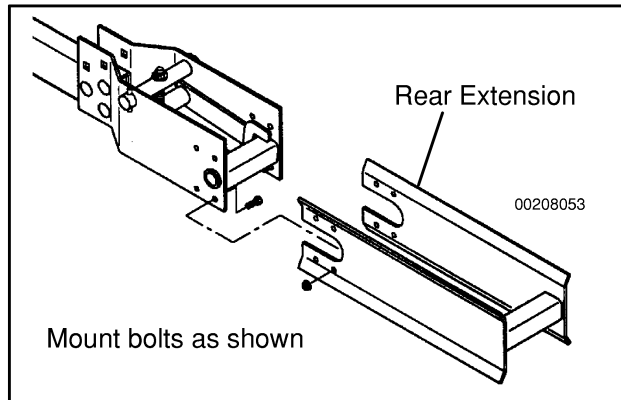

Figure 65. Rear Extension - Model 3030

MODEL 2065

Fasten rear extensions to (2065 cultivator) tree using three 5/8 x 4" carriage bolts and serrated flanged nuts. Slide shank, side plates and spacer plates into rear extension and fasten with four 5/8 x 4" carriage bolts and serrated flanged nuts.

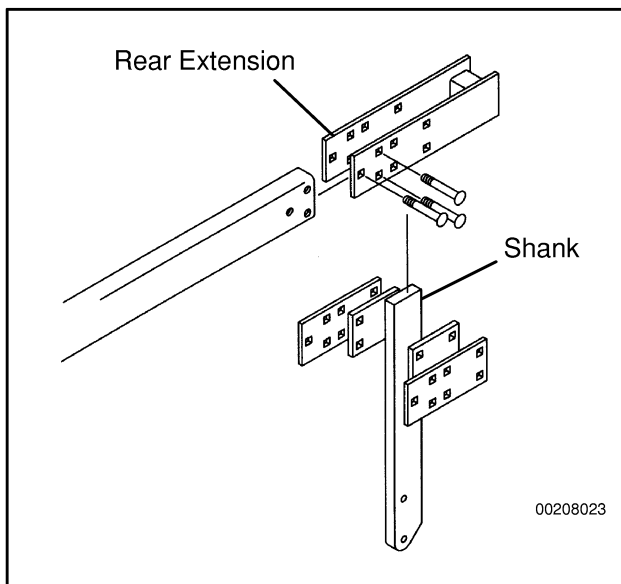

Figure 66. Rear Extension - Model 2065

SPIDER GANG

Fasten rear bracket to tree using 5/8 x 3-1/2 hex bolts and locknuts.

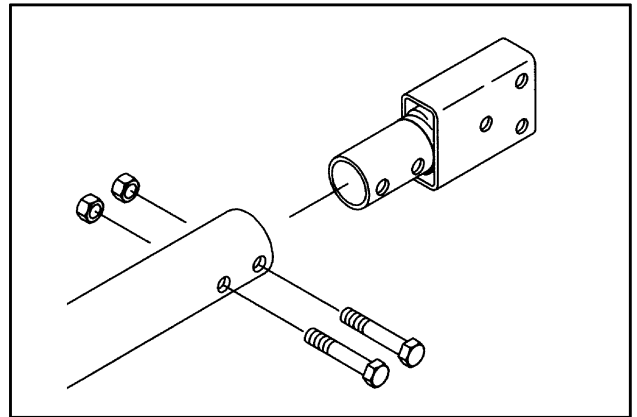

Figure 67. Rear Extension - Spider Gang

Rigid Rear Shank

2065 CULTIVATOR

Mount the shank to rear of tree with two side plates and two spacer plates using 5/8 x 3-1/2" carriage bolts and serrated flanged nuts.

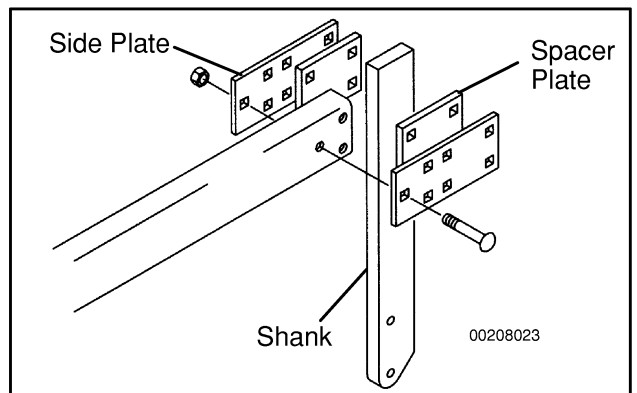

Figure 68. Mounting Shank

2040 CULTIVATOR

Mount clamp assembly to tree using hardware provided with clamp. Slide shank into slot in clamp and fasten with set screws on back side of clamp. Clamp may be placed on inside or outside of rear bracket.

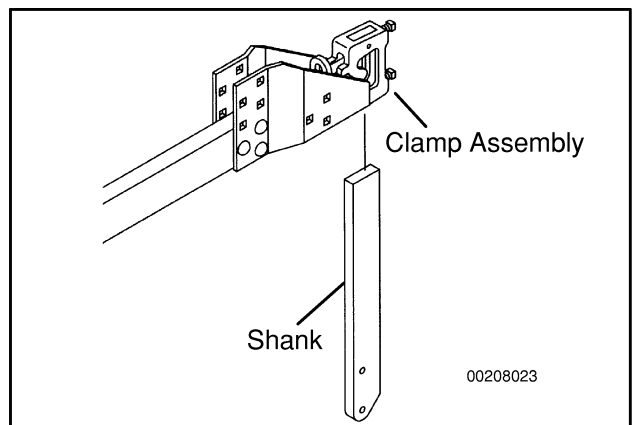

Figure 69. Clamp Mounted Rear Shank

Slide 1/2" serrated flanged nut into hex shaped hole in back of sweep adapter; be sure flange is on inside of sweep adapter. Fasten sweep adapter to shank using spacer plate, two 1/2 x 2-1/2" hex bolts and serrated flanged nuts. Adjust pitch of sweeps using 1/2 x 3" square head set screw and jam nut through flanged nut.

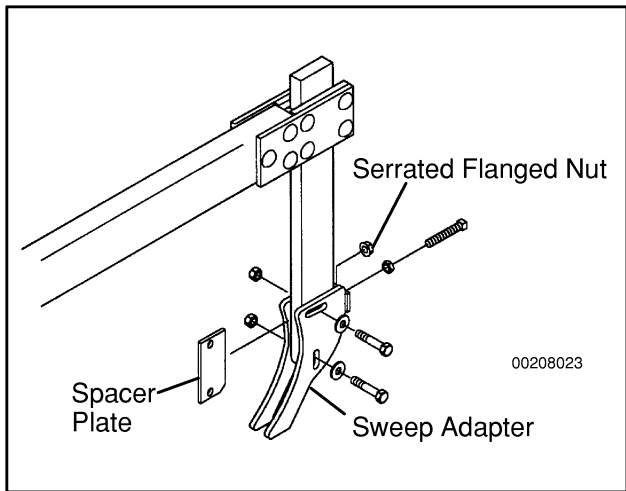

Figure 70. Mounting Sweep Adapter

Rear Trip Shank

Fasten trip assembly to tree using three 5/8 x 3-1/2" carriage bolts and serrated flanged nuts.

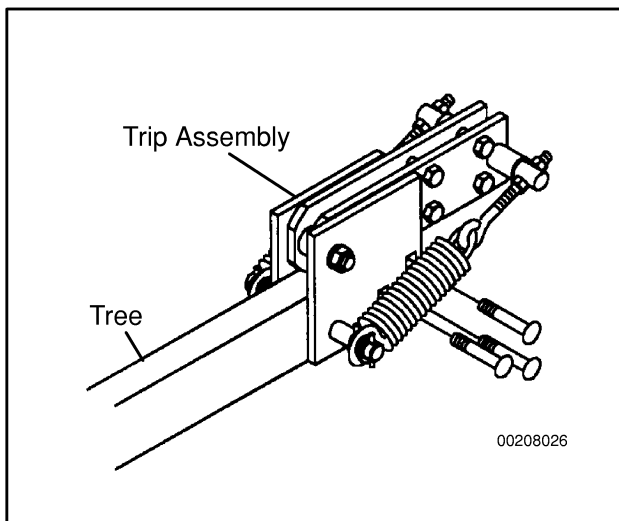

Figure 71. Disc Assembly

Mount shank to trip assembly using the four bolts in trip assembly; be sure shank faces direction shown. Mount sweep adapter as shown on rigid rear shank.

Tighten springs to field condition using eyebolts.

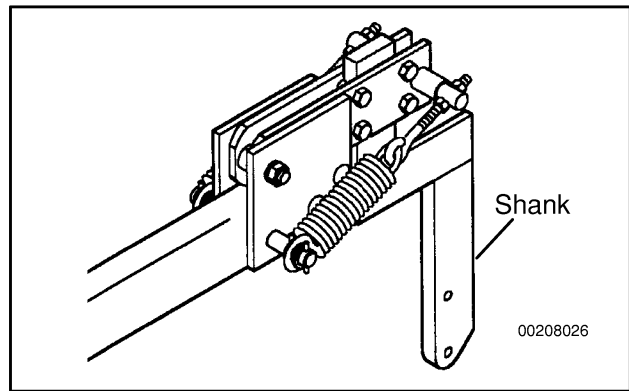

Figure 72. Mounting Shank

Mounting Coultter Discs (2065)

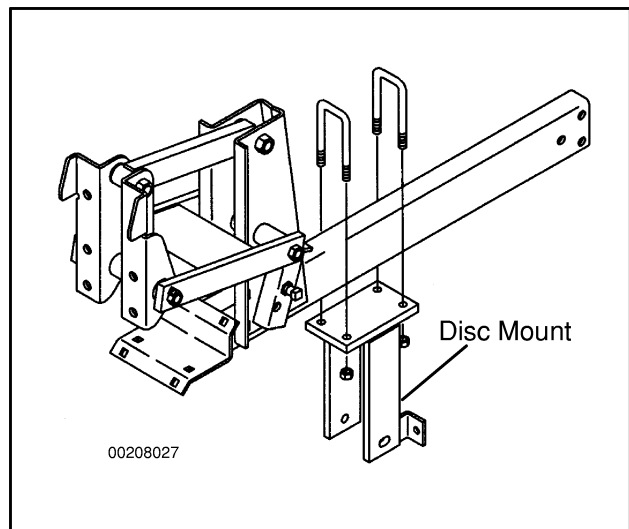

Figure 73. Disc Mount

Fasten disc mount to tree using 1/2" U-bolts and serrated flanged nuts. Mount the disc as close to rear shank as possible.

Fasten hub assembly to disc using 3/8 x 1-1/4" hex bolts, lockwashers and hex nuts.

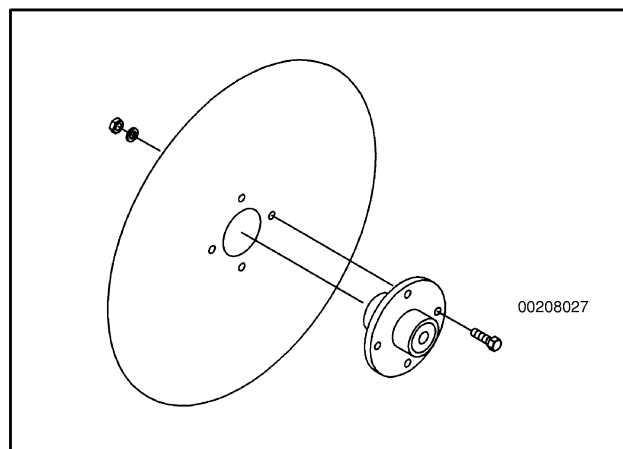

Figure 74. Disc Assembly

Mount disc assembly and adjustment tab to disc mount using 5/8 x 5-1/2" hex bolt and serrated flanged nut. Place 1/2" serrated flanged nut on adjustment tab and slide through ear on mount. Adjust disc to run straight and tighten all hardware. A typical front to rear adjustment of this coultter disc is such that the disc is directly ahead of the front nose of the shovel.

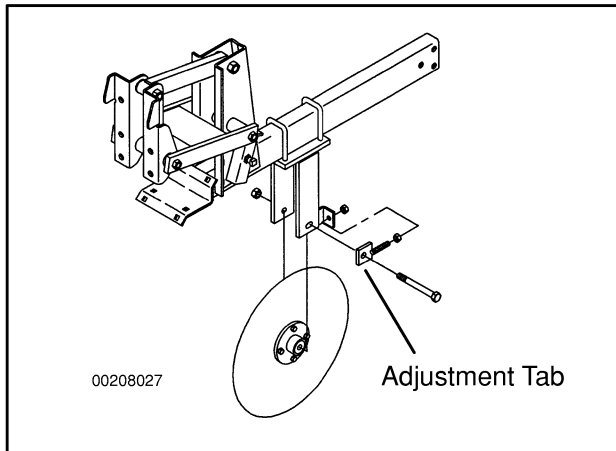

Figure 75. Mounting Disc Assembly

Toggle Trips
CLAMP MOUNTED

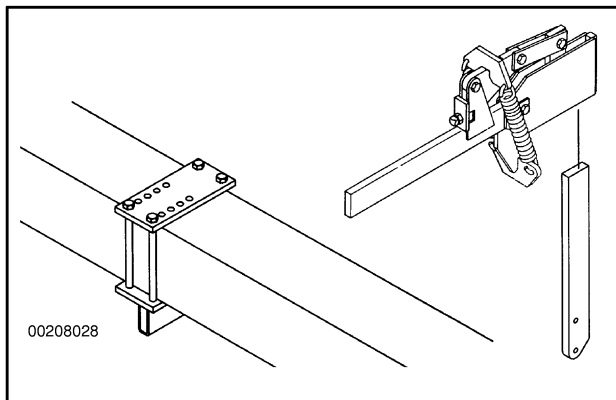

Figure 76. Clamp Mounted Toggle Trip

TREE MOUNTED

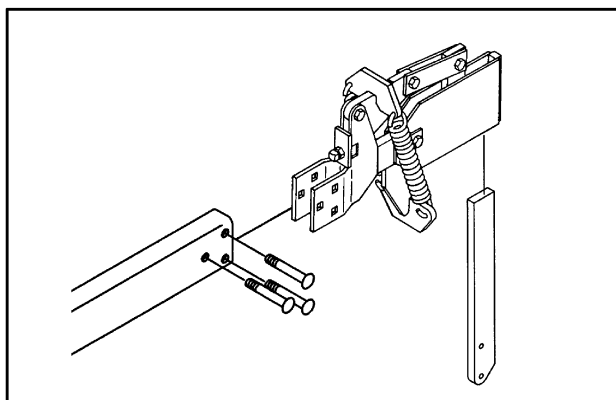

Figure 77. Tree Mounted Toggle Trip

Mount toggle trip assembly to tree using 5/8 x 3-1/2" carriage bolts provided with toggle trip. You may mount clamp to toolbar or trees.

Mount shank into toggle trip and fasten with hardware provided with toggle trip.

Mounting Tines

When mounting tines, a typical setting is with 1" of tine tube exposed beyond tine clamp.

STANDARD S-TINE & PENETRATOR TINE

Mount tine to tube using spring tine clip and (7/16 x 3-1/2" carriage bolt on standard S-tine), (1/2 x 3-1/2" carriage bolt on penetrator tine), lockwasher and hex nut.

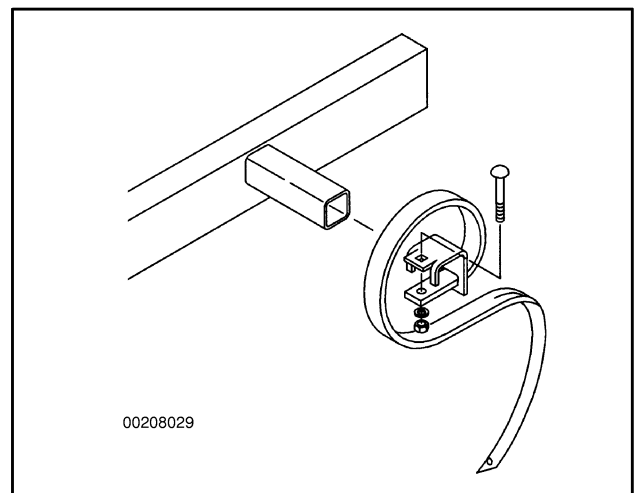

Figure 78. Standard S-Tine & Penetrator Tine

STANDARD S-TINE WITH HELPER SPRING

Place helper spring over tine and mount to tube using spring tine clip and 7/16 x 3-1/2 carriage bolt, lockwasher and hex nut.

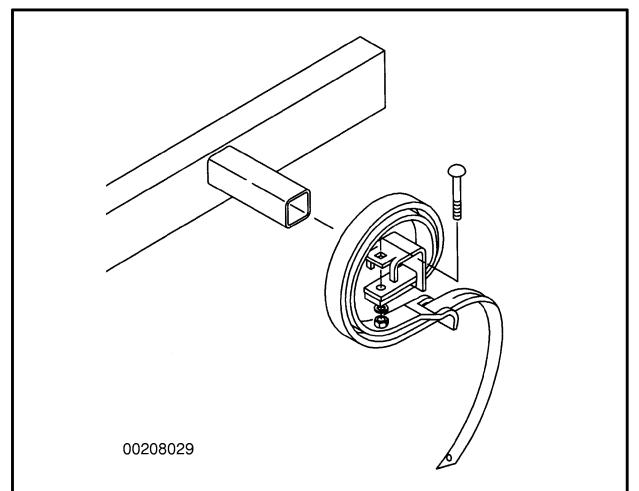

Figure 79. Standard S Tine with Helper Spring

VERTICAL TINE

Place tine clamp plate into tine clamp, slide tine into clamp on opposite side of tube as tine clamp plate. Fasten tine into position using 1/2 x 1-3/4" square head set screw and jam nut. This tine is adjustable for depth.

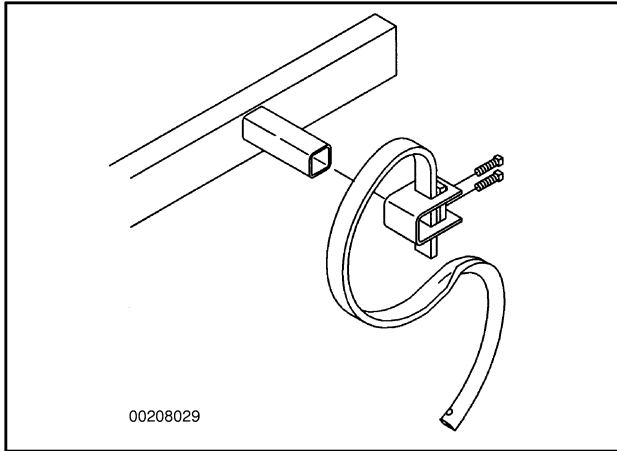

Figure 80. Vertical Tine

STRAIGHT EDGE TINE

Fasten tine to tine plate using 1/2 x 1-1/2" hex bolt and serrated flange nut. Mount tine and plate to tube using 1/2" U-bolts and serrated flange nuts.

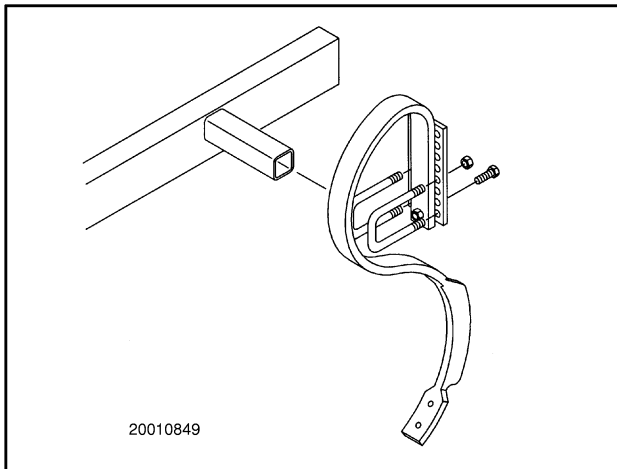

Figure 81. Straight Edge Tine

STRAIGHT EDGE TINE (2130) (OPTIONAL)

Fasten tine to mount using back plate, 1/2 x 1-3/4" hex bolts and serrated flanged nuts.

Fasten tine assembly to rear of tree using four 1/2 x 1-1/4" hex bolts and serrated flanged nuts.

NOTE: Remove rear tine tube.

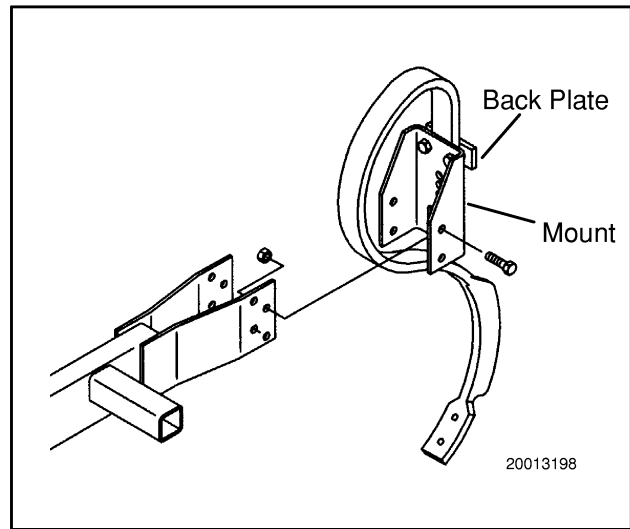

Figure 82. Tine Mount - (Straight Edge Tine)

TIP UP TINE BRACKET (OPTIONAL)

For standard s-tine and penetrator tine.

Fasten tine mount to standard S-tine using 7/16 NC x 1-1/2" hex bolt, lockwasher and hex nut.

Fasten tine mount to penetrator tine using 1/2 NC x 1-1/2" hex bolt lock, washer and hex nut.

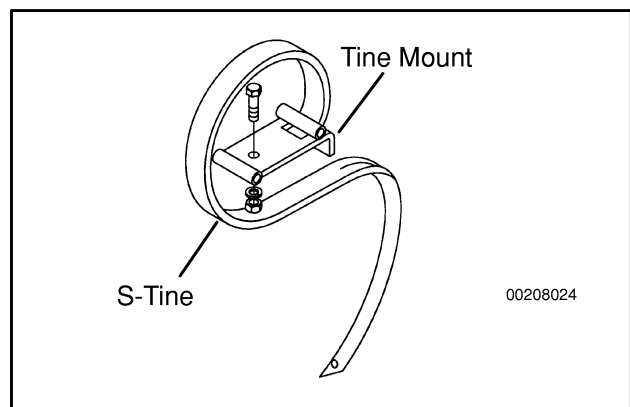

Figure 83. Tine Mount

Slide clamp weldment over tube on tree and fasten using two 3/8 NC x 1" square head set screws.

Fasten tine assembly to clamp weldment using pins. See Figure 84 for pin to tine locations.

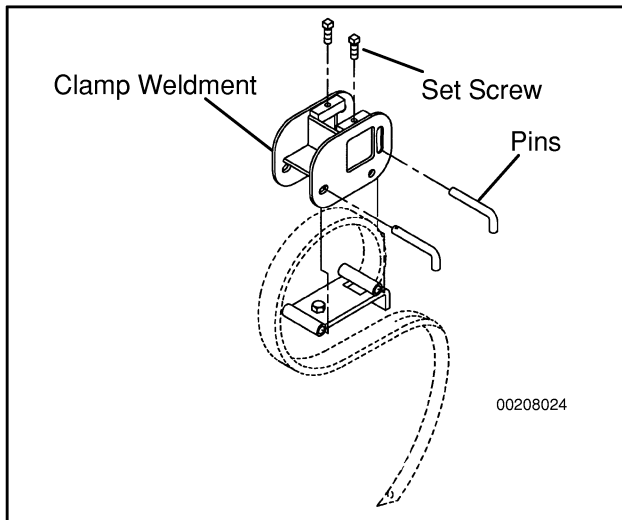

Figure 84. Tine & Clamp Assembly

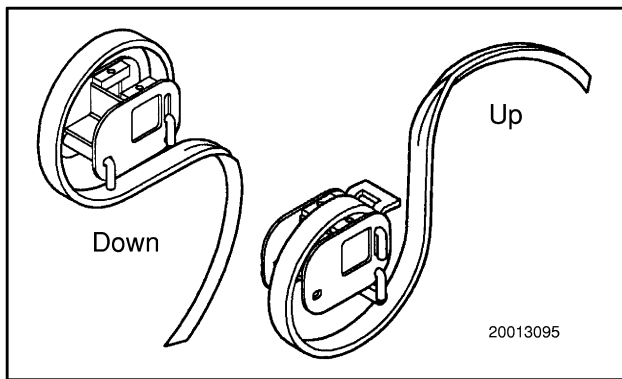

Figure 85. Pin Locations

Mounting Shovels & Sweeps

STANDARD S-TINE & VERTICAL TINE

Fasten shovels to tine using 3/8 x 1-1/2" plow bolt, tine washer and hex nut.

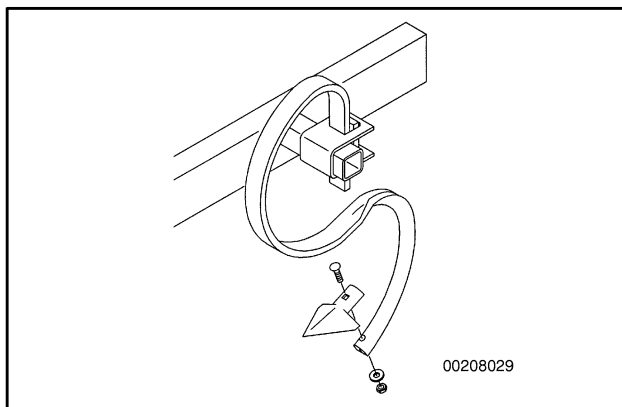

Figure 86. Standard S-Tine & Vertical Tine

PENETRATOR TINE

Fasten shovels to tine using two 7/16 x 1-3/4" plow bolts, flat washers, lockwashers and hex nuts.

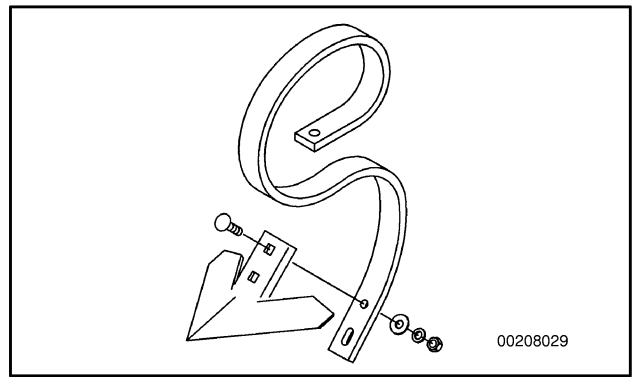

Figure 87. Penetrator Tine

HEAVY DUTY ADJUSTABLE TINE

Fasten shovels to tine using two 7/16 x 2" plow bolts with 1/2" heads, flat washers, lockwashers and hex nuts. Adjust the pitch of shovel by using top or bottom holes in tine.

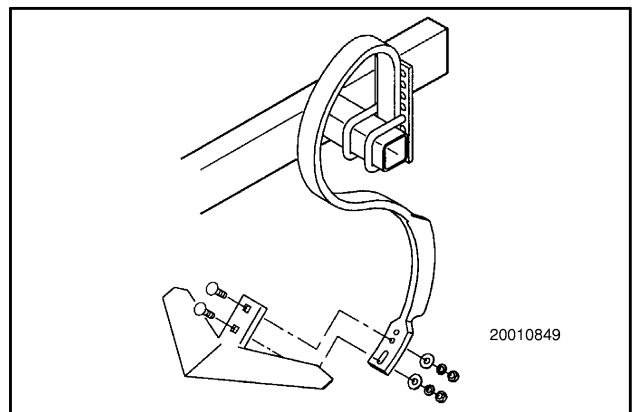

Figure 88. Heavy-Duty Adjustable Tine

REAR SHANK

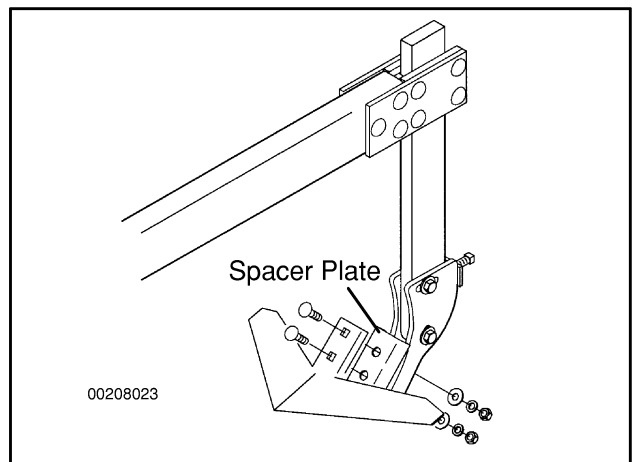

Figure 89. Rear Shank

Fasten shovels to shank using two 1/2 x 3" plow bolts, flat washers, lockwashers and hex nuts. Large sweeps use 1/2 x 3-1/2" plow bolts and spacer plates.

Adjustable Support Wheel



WARNING

- Before folding or unfolding cultivator:
 - Make sure you have adequate clearance on each side and overhead.
 - Make sure wing cylinder restrictor fittings are properly installed.
 - Make sure wing-mounted gauge wheels and guide coulters will not contact tractor cab or tires.

IMPORTANT

- These wheels may not be used behind tractor tires.
- When using adjustable support wheels, measure tractor and cultivator carefully and locate support wheels so that they will not hit tractor cab when toolbar is folded.

MEASURE SUPPORT WHEEL LOCATION (Figure 90)

Some tractor cabs or accessories may interfere with cultivator support wheels when folding and unfolding the cultivator.

Measure and record distance "A" from wing hinge pin to the tractor obstruction (operator cab, etc.). Measure and mark the same distance from hinge pin to a point on the wing "B". Support wheels may be located on cultivator wings inside that point. Support wheels must not be located further toward the end of the wing than the previously recorded distance.

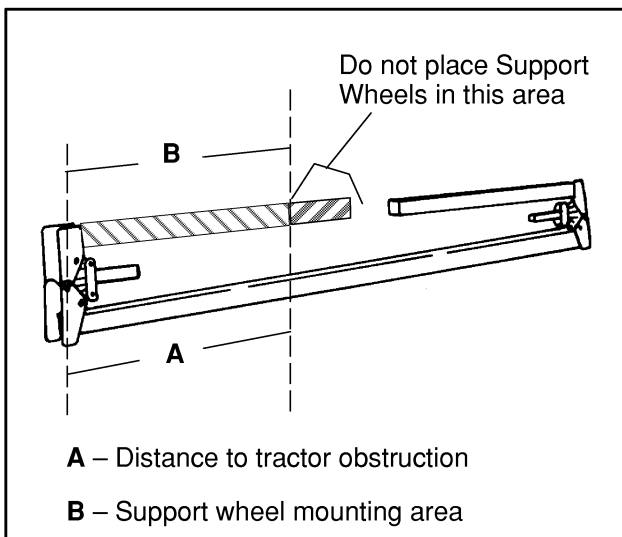

Figure 90. Locating Support Wheels

FASTEN STRUT MOUNT

Fasten strut mount using two 3/4" U-bolts, lockwashers and hex nuts.

Note: Mount guide and support wheels over a linkage facing towards the tractor. Do not tighten the U-bolts until assembly is complete.

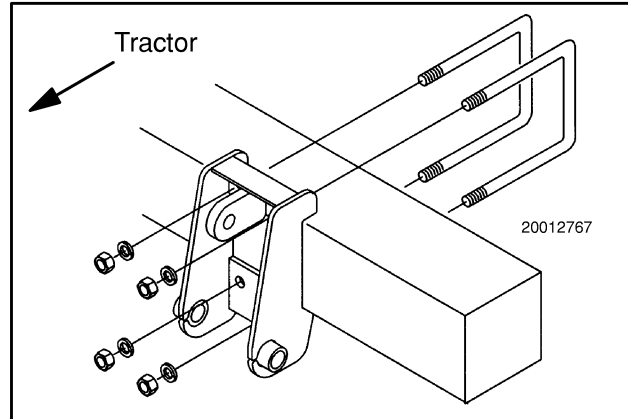

Figure 91. Fastening Strut Mount

MOUNTING PIVOT ARM

Attach pivot arm using pin and two 5/16 x 1-5/8" roll pins.

When mounting pivot arms, be sure that left and right sides are opposite each other. The spindle side either faces the tractor or both face outward.

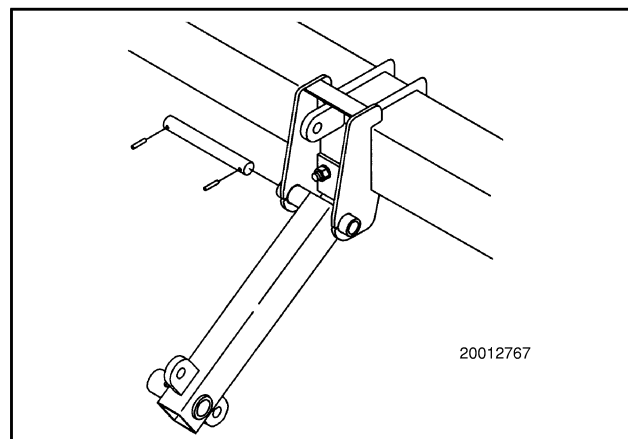

Figure 92. Mounting Pivot Arm

ATTACH SCREWJACK

Attach screwjack using two 1 x 3" hex bolts, lockwashers and hex nuts.

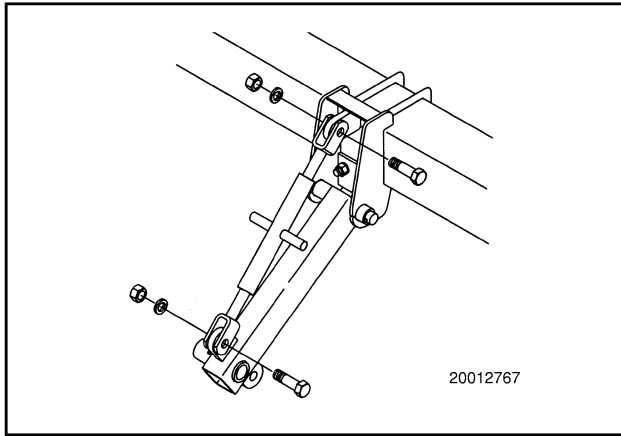

Figure 93. Attaching Screwjack

FASTEN HUB AND SPINDLE ASSEMBLY

Fasten hub and spindle assembly using 1/2 x 3" hex bolt, lockwasher and hex nut.

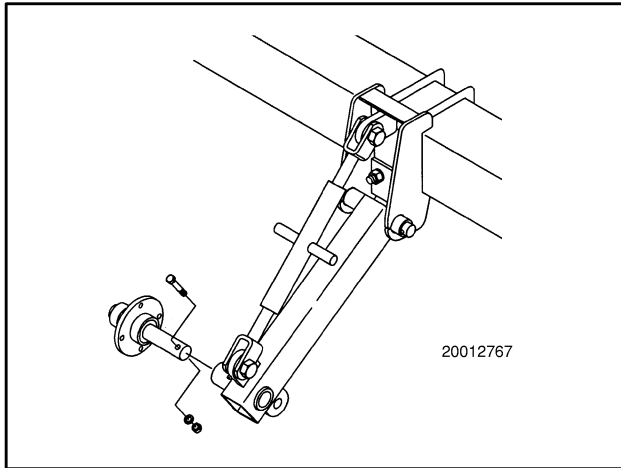

Figure 94. Fastening Hub & Spindle Assembly

FASTEN TIRE AND RIM ASSEMBLY

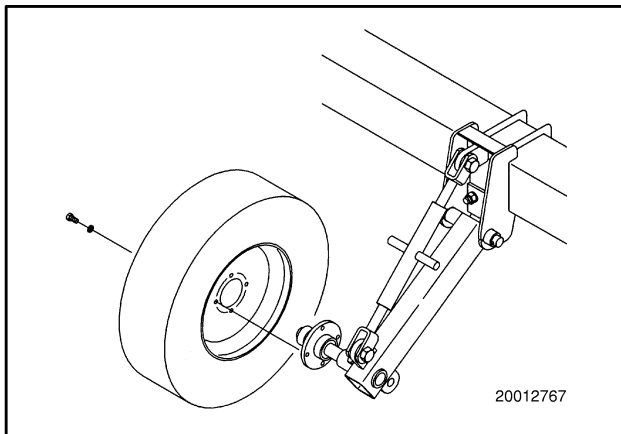

Figure 95. Fastening Tire & Rim Assembly

Fasten tire and rim assembly using bolts provided in hub.

If you have a guide wheel, be sure tire is centered over the guide marks, then tighten U-bolts on mount.

Semi-Pneumatic & Steel Guide Wheel
IMPORTANT

■ When using semi-pneumatic or steel guide wheels, measure tractor and cultivator carefully and locate wheels so that they will not hit tractor cab when toolbar is folded.

■ When placing behind tractor tires, carefully check the clearance in all positions. Some tractors without quick hitch may not have adequate clearance when the cultivator is raised.

Mount guide wheels centered over guide marks using U-bolts provided. For some applications, these wheels may be mounted behind tractor tires.

Adjust wheels by removing bolt in angle and turning adjustment plate.

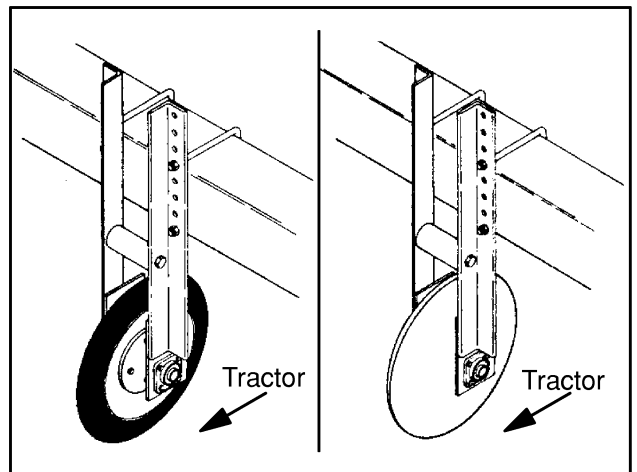

Figure 96. Semi-Pneumatic & Steel Guide Wheels

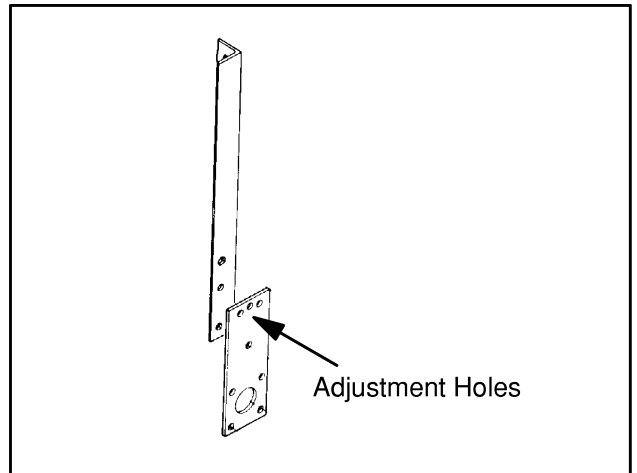

Figure 97. Adjusting Wheel

Curved Arm Support Wheel & Single Rib Guide Wheel

FASTEN WHEEL MOUNTING BRACKET

Fasten wheel mounting bracket using two 3/4" U-bolts, lockwashers and hex nuts.

Note: Do not tighten the U-bolts until assembly is complete.

IMPORTANT

■ When using curved arm support wheels, measure tractor and cultivator carefully and locate wheels so that they will not hit tractor cab when toolbar is folded. These wheels may not be used behind tractor tires.

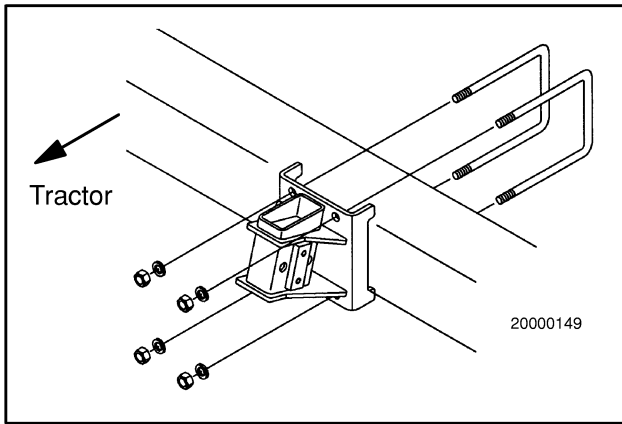

Figure 98. Fastening Wheel Mounting Bracket

MOUNTING SUPPORT WHEEL ARM

Attach support wheel arm using pin and two 1/2 x 1-1/2" square head set screws. The set screws are used to adjust the wheels square to the toolbar.

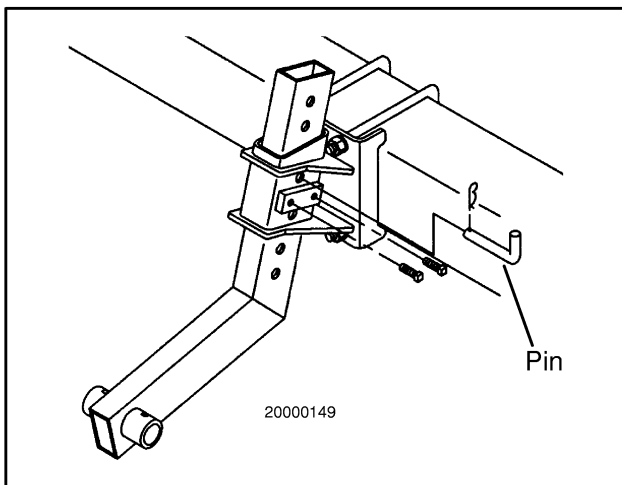

Figure 99. Mounting Support Wheel Arm

FASTEN HUB AND SPINDLE ASSEMBLY

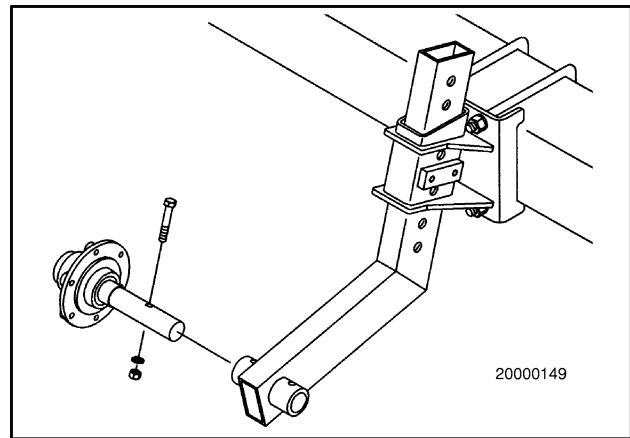

Figure 100. Fastening Hub & Spindle Assembly

Fasten hub and spindle assembly using 1/2 x 3" hex bolt, lockwasher and hex nut.

When mounting spindle assembly, be sure that left and right guide wheels are opposite each other. The spindles either face the tractor or both face outward.

FASTEN TIRE AND RIM ASSEMBLY

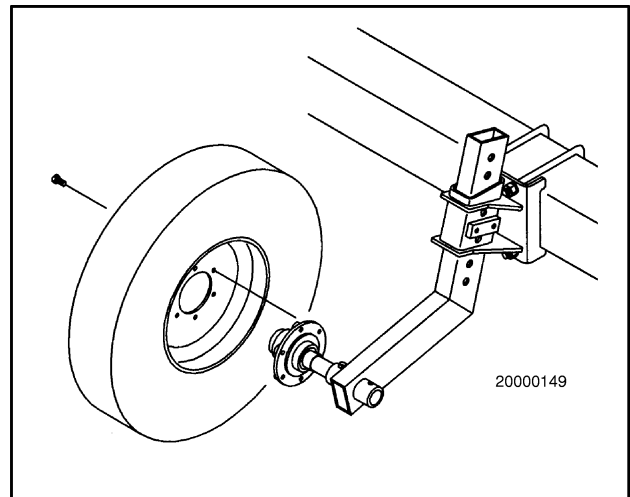

Figure 101. Fastening Tire & Rim Assembly

Fasten tire and rim assembly using bolts provided in hub. Move so tire is centered on linkage assembly and tighten nuts.

Front Parking Stands

Two front parking stands are included with all cultivators and must be installed at each end of the toolbar center section as shown in Figure 102.

TRR and F toolbars: Locate parking stand assembly between row units and fasten to front side of toolbar using 5/8" U-bolts and flanged nuts.

TRF toolbars: Attach front parking stands to short hinge tubes of reinforced folding toolbars as shown in Figure 8, using 5/8" U-bolts and flanged nuts.

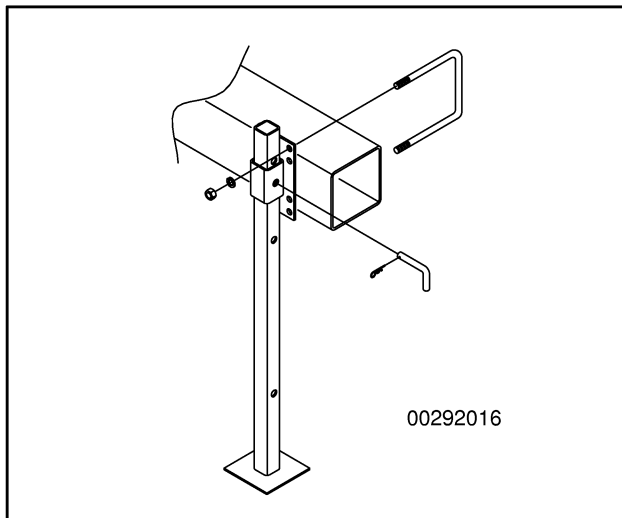

Figure 102. Mounting Parking Stand

Rear Parking Stands (TRF and F Toolbars)

Rear parking stands are included with all folding toolbar cultivators (TRF and F). Rear parking stands must be used for all folding toolbar cultivators not equipped with lift assist wheels.

Locate rear parking stand assemblies between row units as near the outer ends of the center frame as possible and attach using 5/8" U-bolts and flanged nuts.

Rear parking stands must be placed so that there is no interference with optional equipment.

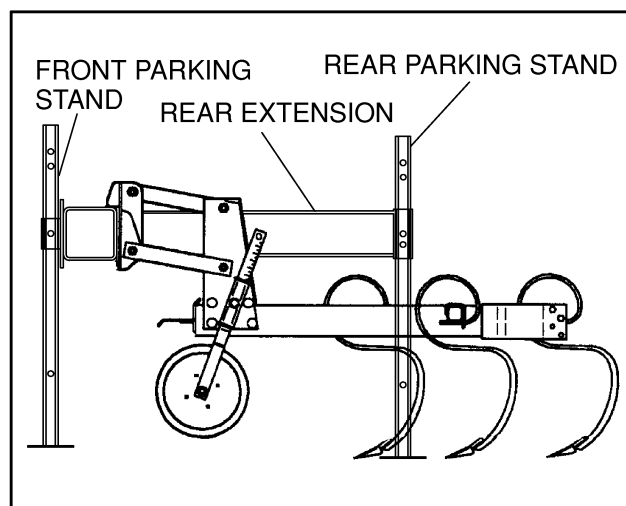

Figure 103. Front and Rear Parking Stands (Type F Toolbar)

Front Stabilizer Couler

Fasten stabilizer assembly to front side of toolbar using 5/8" U-bolts and serrated flanged nuts provided with assembly.

Recommended quantity: two per 4–12 row cultivators; four per larger cultivators.

IMPORTANT

- These coulers may not be used behind tractor tires.
- If mounted on flat folding cultivators, must be located as to not hit tractor cab when toolbar is folded.

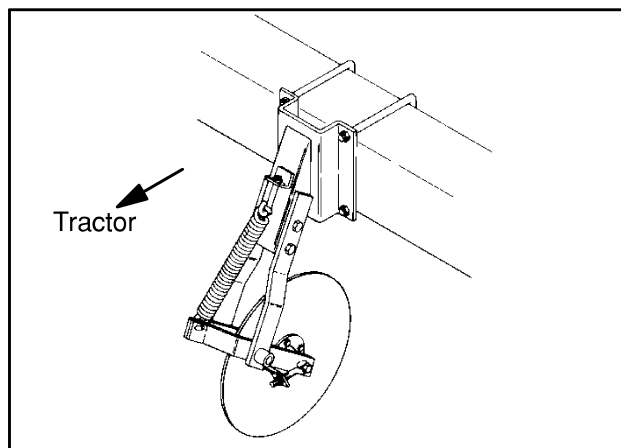

Figure 104. Mounting Stabilizer Couler Assembly

Rear Stabilizer Couler

FASTEN MOUNTING FRAME

Fasten mounting frame to toolbar using 3/4" U-bolts, lockwashers and hex nuts. Be sure frame is centered over cultivator gang. Do not tighten nuts at this time.

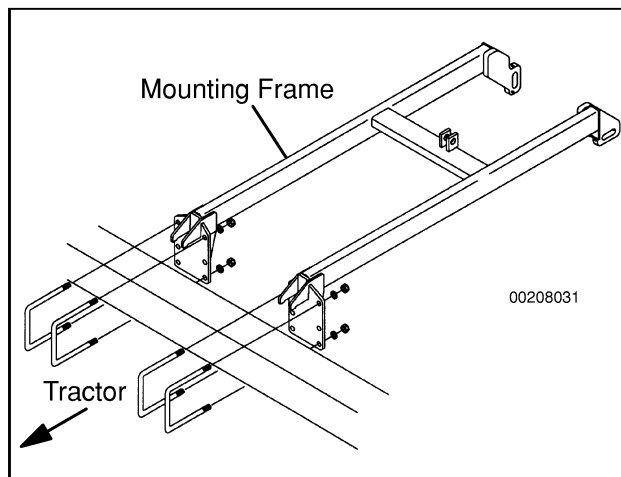

Figure 105. Fastening Mounting Frame

MOUNTING REAR FRAME

Fasten rear frame to mounting frame using two 1 x 5" hex bolts, flat washers, lockwashers and hex nuts. Be sure to place flat washers as shown.

Center rear frame using four 3/8 x 3-1/2" square head set screws with jam nuts.

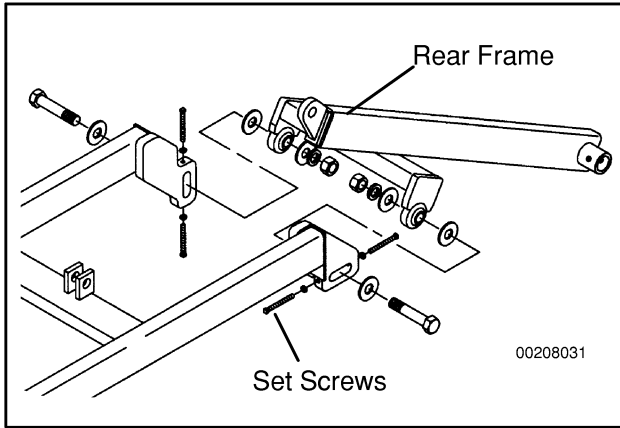

Figure 106. Mounting Rear Frame

MOUNTING SCREW JACK

Place rubber bushing into arm weldment and fasten to mounting frame using 1 x 3-1/2" hex bolt, lockwasher and hex nut.

Fasten screw jack to arm weldment and rear frame using pins provided with screw jack.

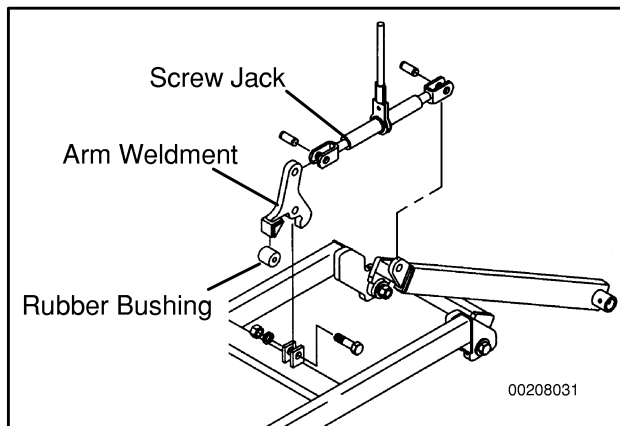

Figure 107. Mounting Screw Jack

MOUNTING DISC

Fasten hub assembly to rear frame using 1/2 x 3" hex bolt and hex nut.

Fasten disc to hub using 1/2" lockwashers and hex nut.

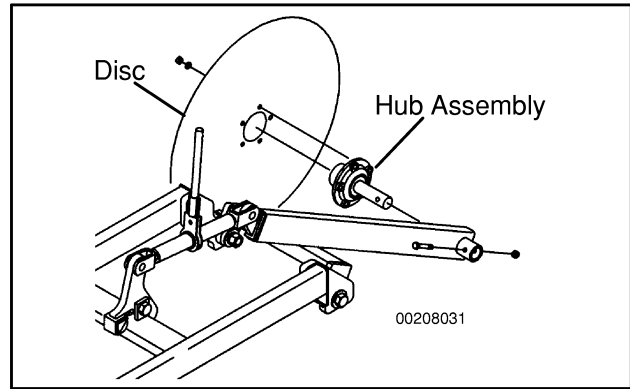

Figure 108. Mounting Disc

Slide Mount Assembly (Shields)

FASTEN SLIDE MOUNT

Slide 1/2 NC x 3-1/2" carriage bolts into bolt locations in slide mount, place slide mount on tree in desired location. Place spacer between plates on slide mount above carriage bolts. Tighten bolts using serrated flanged nuts.

Do not tighten bolts until assembly is complete.

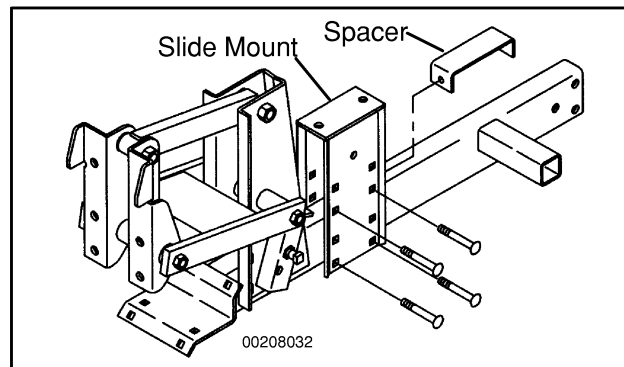

Figure 109. Fastening Slide Mount & Spacer

LOCATIONS OF BOLTS AND SPACER

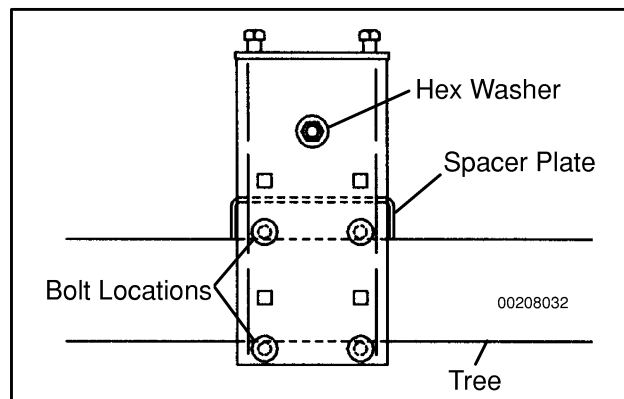

Figure 110. Spacer Plate Location

Note the locations of bolts and spacer plate. On 5-tine 2040 cultivators you may bolt branches directly over slide mount.

MOUNTING TEE WELDMENT

Fasten 1/2 NC x 3-1/2 hex bolt, flat washer and locknut into top hole in slide mount. Slide tee weldment over bolt and tighten.

Attach 1/2 NC x 1-1/2 hex bolts and jam nuts into top of Slide Mount.

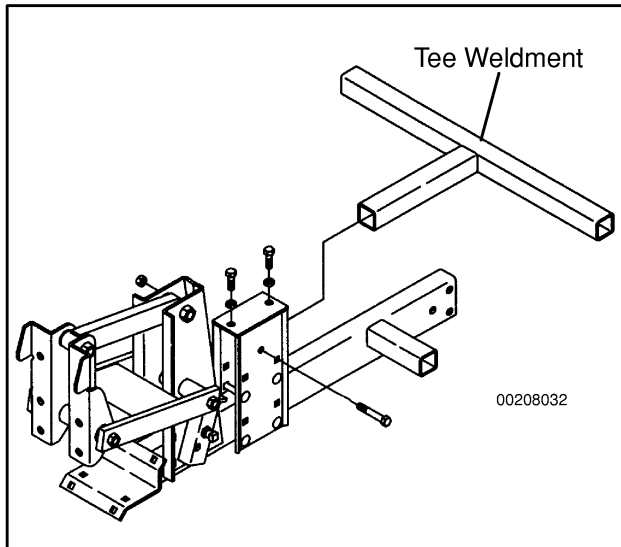

Figure 111. Mounting Tee Weldment

Adjust pitch of shields by adjusting 1/2 NC x 1-1/2" hex bolts on top of slide mount. Front 1/2 x 1-1/2" bolt sets pitch of shields, rear 1/2 x 1-1/2" bolt is for locking tee into place.

NOTE: Model 2040 adjustable tine branches may be mounted directly over holes in slide mount.

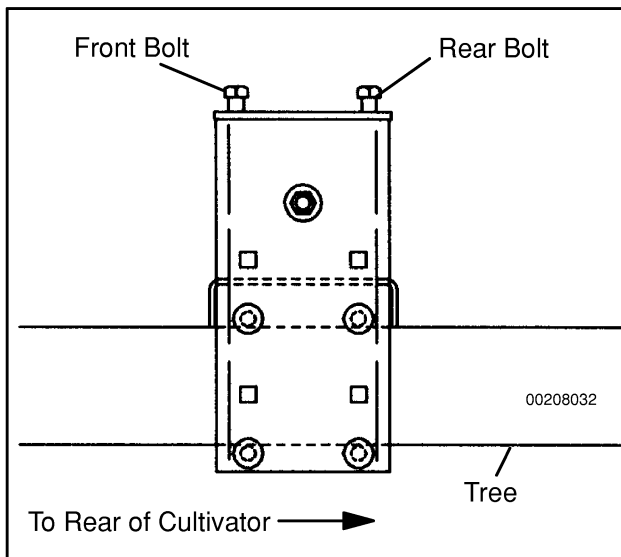

Figure 112. Adjusting

FASTEN TUNNEL MOUNT ASSEMBLIES

Slide tunnel mount assemblies over tee weldment and tighten bolt.

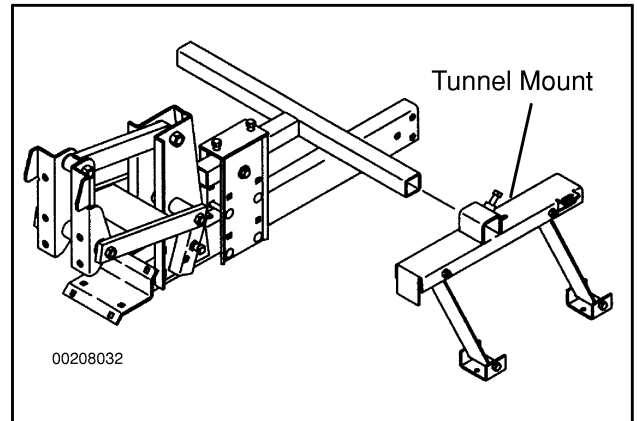

Figure 113. Fastening Tunnel Mount Assembly

FASTEN TUNNEL SHIELDS & ADJUSTMENT STRAP

Fasten tunnel shields to tunnel mount assemblies using back plate, 3/8" clip, 3/8 NC x 1" carriage bolt, lockwasher and hex nut.

Slide adjustment strap through slot in tunnel mount assembly and fasten to front pivot strap using 7/16 NC locknut and hair pin cotter. Be sure tunnel shields are centered over the rows and tighten all bolts.

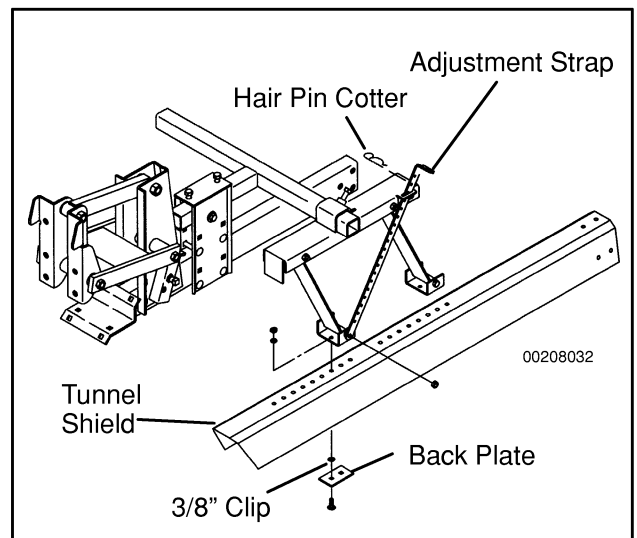

Figure 114. Tunnel Shields & Adjustment Strap

Center Mount Tunnel Shields

FASTEN TUBE ATTACH WELDMENT

Fasten tube attach weldments to tree using 1/2 x 3-1/2" carriage bolts and serrated flanged nuts. Center the tube between first and second branch on tree.

Do not tighten bolts until assembly is complete.

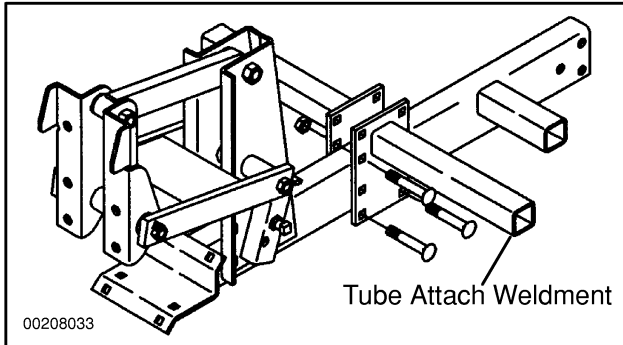

Figure 115. Fastening Tube Attach Weldment

FASTEN MOUNT ASSEMBLY

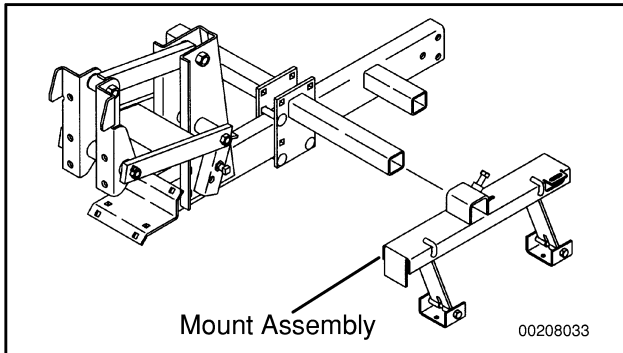

Figure 116. Fastening Mount Assembly

Slide the mount assembly over the tube attach weldments and tighten bolt.

MOUNT ADJUSTMENT STRAP

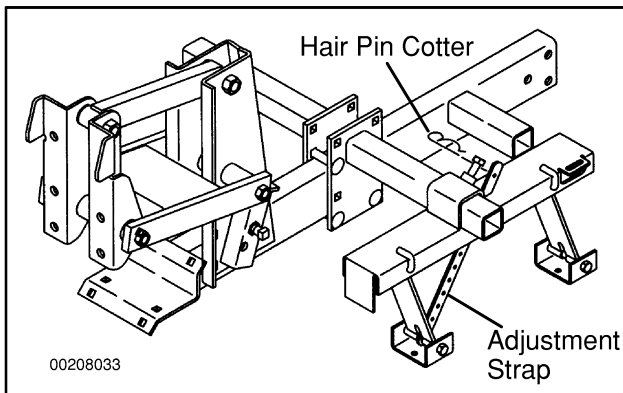

Figure 117. Mounting Adjustment Strap

Remove the bolt from bottom of front pivot arm slide adjustment strap between slot in pivot arm and replace bolt and nut. Fasten 5/32" hair pin cotter to hole in top side of adjustment strap.

FASTEN TUNNEL SHIELDS

Fasten tunnel shields to tunnel mount assemblies using back plate, 3/8" clip, 3/8 NC x 1" carriage bolt, lockwasher and hex nut. Be sure tunnel shields are centered over the rows and tighten all bolts.

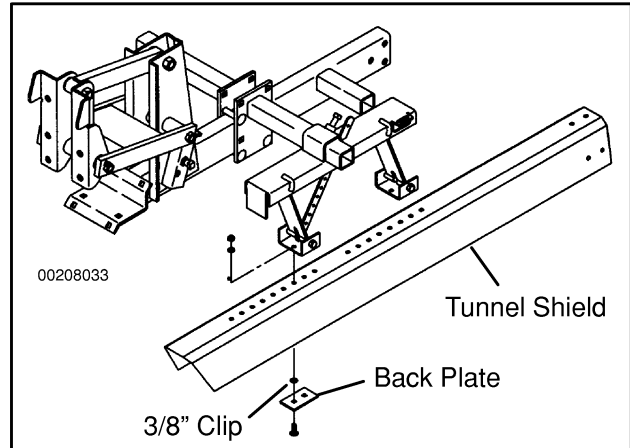

Figure 118. Fastening Tunnel Shields

Tunnel Shield Extensions

Fasten tunnel shield extension to tunnel shield using three 3/8 x 3/4" hex bolts and serrated flanged nuts. Be sure the nuts are on outside of shield.

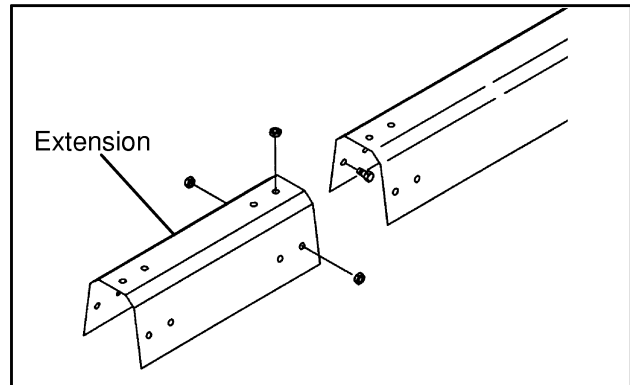

Figure 119. Mounting Tunnel Shield Extension

Tunnel Shield Dirt Sweeps

Fasten tunnel shield dirt sweeps to tunnel shield using (four) 3/8 x 3/4 hex bolts and serrated flanged nuts. Be sure the nuts are on outside of shield.

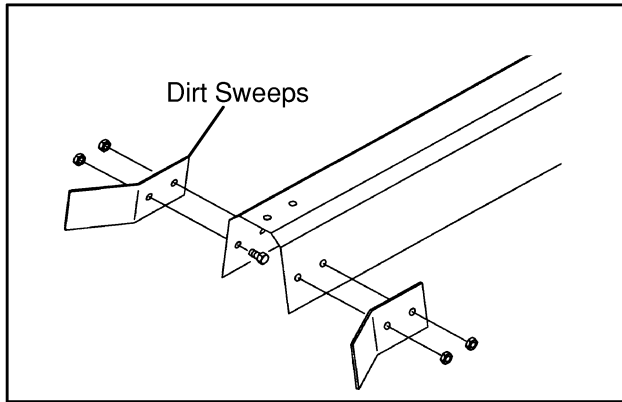

Figure 120. Fastening Tunnel Shield Dirt Sweeps

VARIABLE WIDTH TUNNEL SHIELDS

ASSEMBLE TUNNEL SHIELD

Fasten left and right tunnel shield halves together using two 3/8 x 1" carriage bolts, flat washer, lockwasher and hex nut. Adjust to desired width and tighten bolts.

After assembly is complete, mount tunnel shield to tunnel mount as shown at top of page.

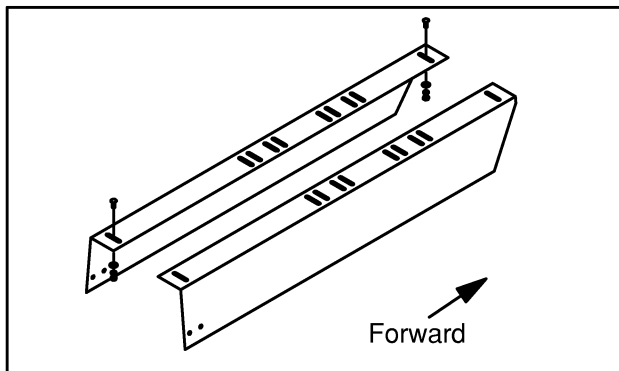

Figure 121. Fastening Shields Together

END SHIELD

FASTEN MOUNT ASSEMBLY

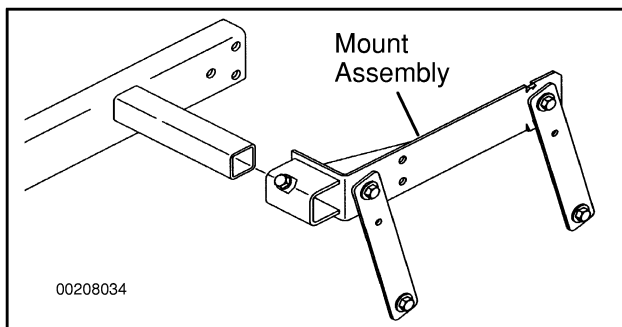

Figure 122. Fastening Mount Assembly

Slide end shield mount assembly over tree and tighten bolt.

Never attach end shield brackets so they face towards tractor. On model 2040 and 2065 cultivators, a bolt-on branch is required to attach shields.

FASTEN END SHIELD

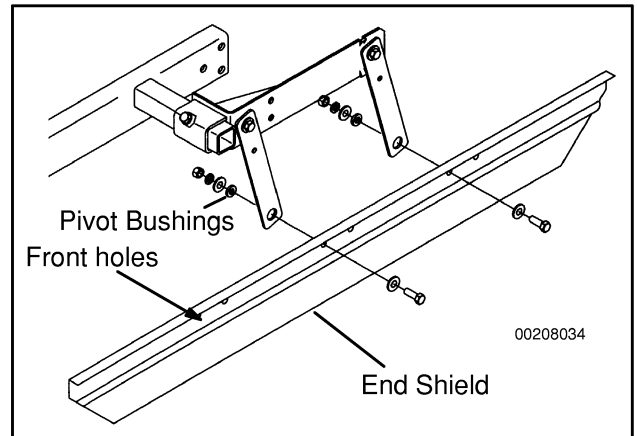

Figure 123. Fastening End Shields

Fasten end shield to mount assembly using hardware provided. The picture shows mounting to rear tine branch. Mount front pivot strap in front holes when mounting to front tine branch. Make sure pivot bushings are not left out. Make sure pivot arms are parallel to each other when doing assembly as they may be attached in wrong holes.

ROLLING SHIELDS

TOOLBAR MOUNTED (MODEL 2040)

Fasten mount to toolbar using 5/8" U-bolt and serrated flanged nuts. Be sure mounts are centered over the row.

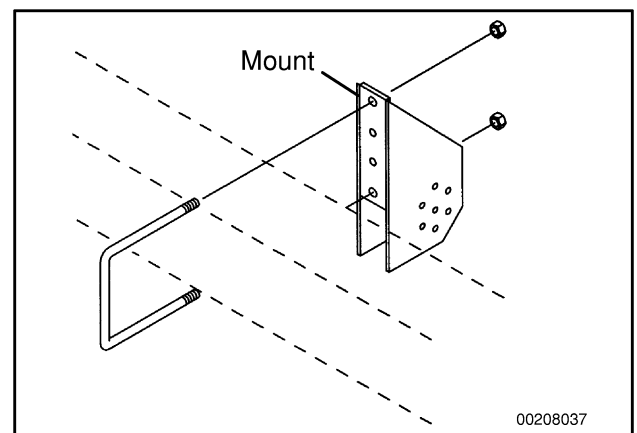

Figure 124. Toolbar Mounted

TOOLBAR MOUNTED (JEFFERS)

Fasten mount to toolbar using 5/8" U-bolt and serrated flanged nuts. Be sure mounts are centered over the row.

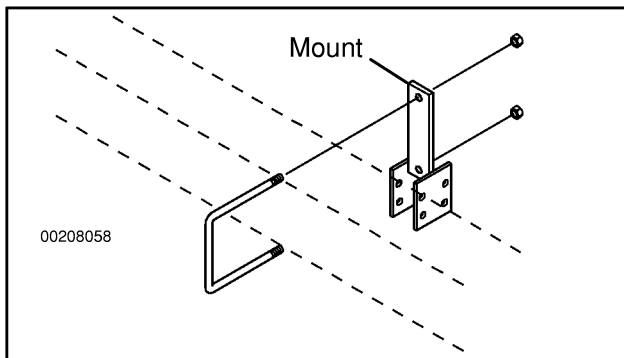

Figure 125. Toolbar Mounted

BRANCH MOUNTED

Fasten tube attach weldments to tree using 1/2 x 3-1/2" carriage bolts and serrated flanged nuts. Center the tube on the tree.

Do not tighten bolts until assembly is complete.

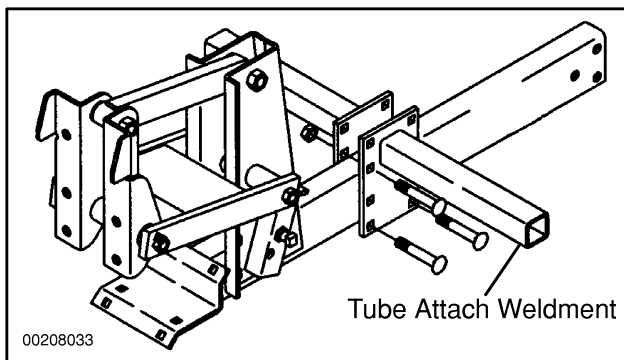

Figure 126. Branch Mounted

REAR TINE BRACKET MOUNTED (MODEL 3030)

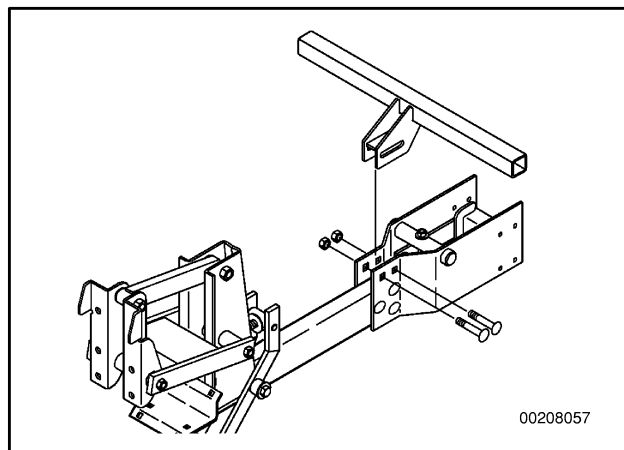

Figure 127. Rear Tine Bracket Mounted

Fasten fixed shield mount to rear tine bracket using two 5/8 NC x 3" carriage bolts and serrated flanged nuts.

BRANCH MOUNTED

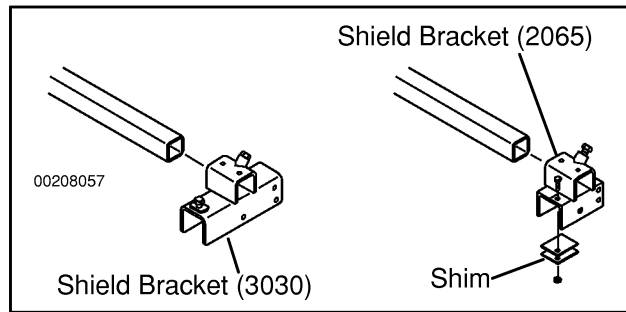

Figure 128. Branch Mounted

Fasten shield bracket to tube using bolt on shield bracket. On Model 2065, attach shims to bracket using 5/16 x 1" hex bolt and serrated flanged nut. Shims are used to adjust down travel when cultivator is raised.

FASTENING TUBES (7 X 7" MOUNTED)

Fasten upper tube to the mount using bushings and 7/16 NC x 4" hex bolt with serrated flanged nut.

Slide lower tube into upper tube and fasten with bolt on upper tube.

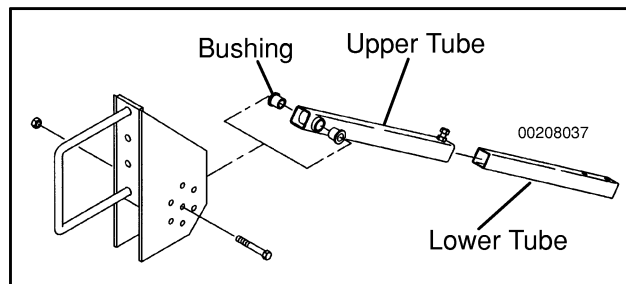

Figure 129. Fastening Tubes

FASTENING TUBES (BRANCH MOUNTED)

Fasten upper tube to the bracket using bushings and 7/16 NC x 4" hex bolt and serrated flanged nut.

Pivot tube into up position and fasten using pin.

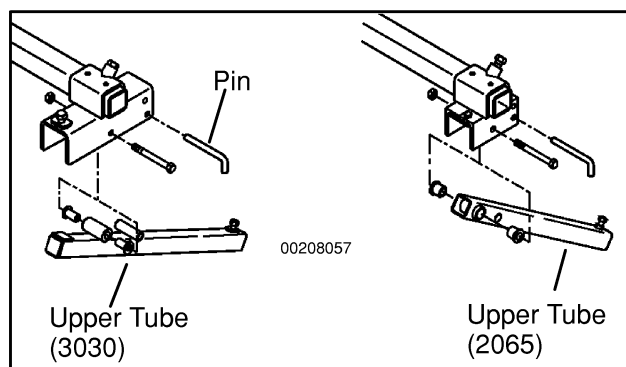

Figure 130. Fastening Tubes

ATTACHING LOWER TUBES AND SHIELDS

Slide lower tube into upper tube and fasten using bolt on upper tube.

Remove nut and lockwasher from spindle assembly. Slide spacer plates and shields onto spindle assembly and fasten using lockwasher and nut.

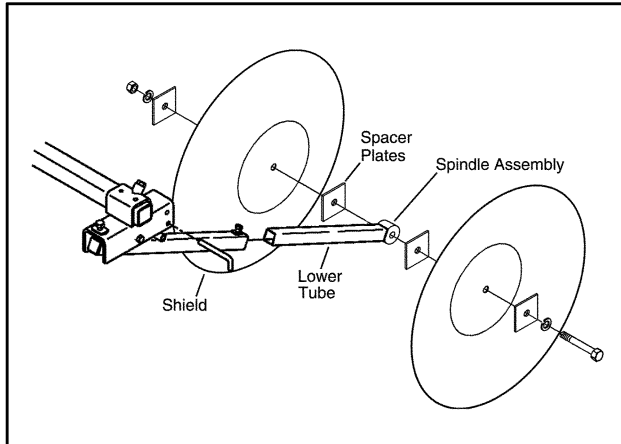

Figure 131. Fastening Tubes & Shields

OFFSET BRACKETS

These brackets are used to get around 3-point hitches or hinges on folding toolbars.

Slide one offset tube into upper tube and tighten bolt. Slide the other offset tube into the tube at end of offset tube and tighten bolt. Reattach bottom assembly.

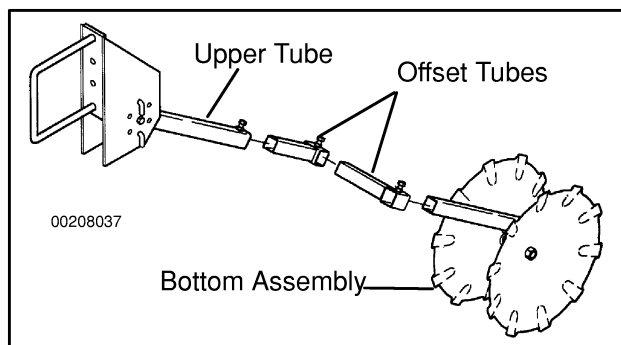

Figure 132. Offset Brackets

FASTENING TUBES (TEXAS ROLLING SHIELDS)

Fasten upper tube to the bracket using L-pin and cotter pin in hole shown. Place other pin and hair pin cotter in back hole to hold upper tube in transport position.

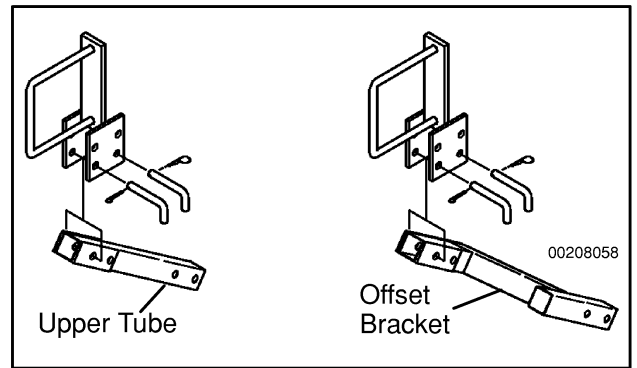

Figure 133. Fastening Upper Tubes

SHIELD ASSEMBLY (TEXAS ROLLING SHIELD)

Attach zerk to lower tube weldment. Assemble axle, bearings, dust caps, shields and washers using 1/2 x 9" hex bolt, lockwashers and hex nuts.

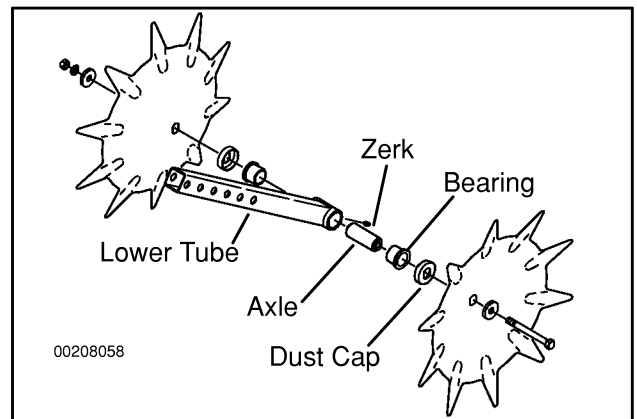

Figure 134. Shield Assembly

ATTACHING SHIELD ASSEMBLY (TEXAS ROLLING SHIELDS)

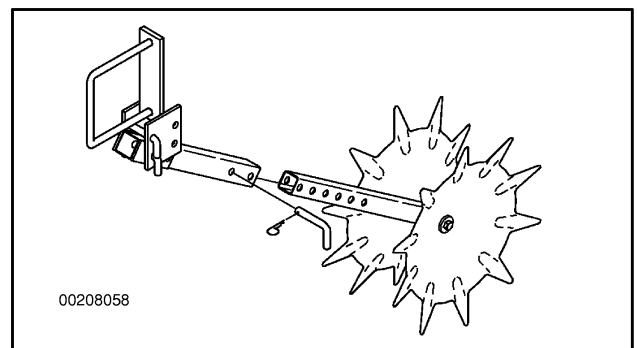

Figure 135. Attaching Shield Assembly

Attach shield assembly to upper tube using L-pin and hair pin cotter.

Open Top Shields

FASTENING MOUNT TO TREE

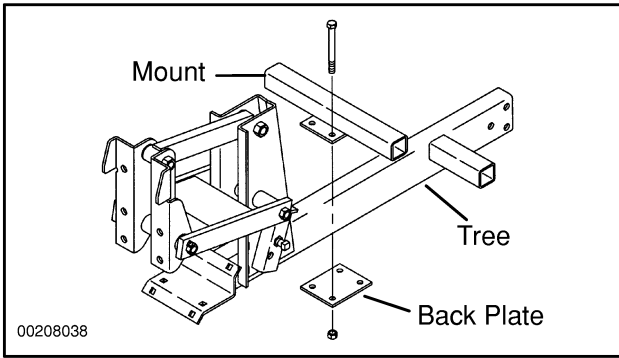

Figure 136. Fastening Mount

Fasten mount to tree centered between the branches using back plate and four 1/2 x 5" hex bolts on 2 x 4" trees or four 1/2 x 3" hex bolts on 2 x 2" trees with serrated flanged nuts.

FASTENING MOUNT TO SPIDER TREE

Fasten mount to back plate using serrated flanged nuts. Fasten mount and back plate to tree using U-bolts and serrated flanged nuts.

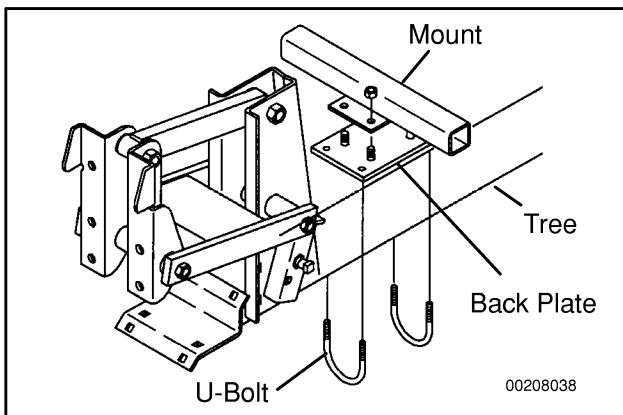

Figure 137. Fastening Mount - Spider Tree

ASSEMBLING SHIELDS

Fasten parallel arms to shields using 7/16 x 1-1/4" hex bolts on back arm and 7/16 x 2" hex bolts on front arm with flat washers and locknuts.

Fasten pivot bracket to parallel arms using 7/16 x 1-1/4" hex bolts and locknuts.

Attach chain to 7/16 x 2" hex bolt on front parallel arm using locknut and run to pivot bracket, fastening with 3/8 x 2-3/4" clevis pin, 5/16" flat washer and hair pin cotter.

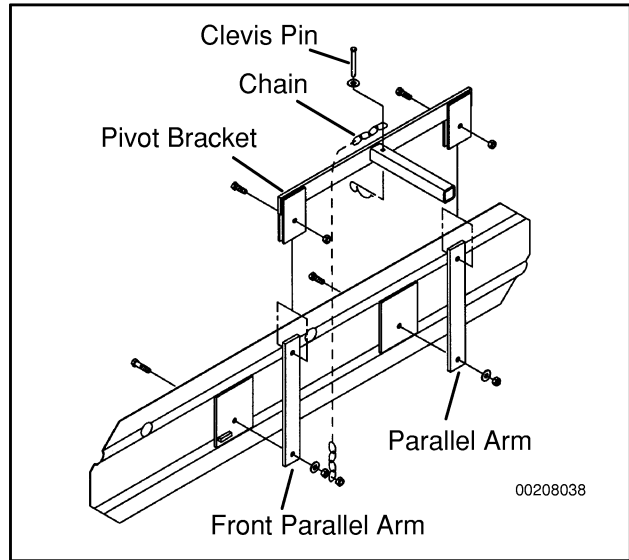

Figure 138. Assembling Shields

ATTACHING SHIELD ASSEMBLY

Slide shield assemblies into mount weldment and fasten into place with 1/2 x 1" square head set screws.

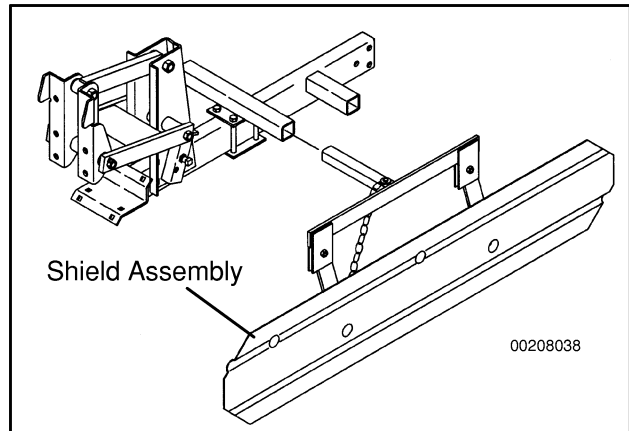

Figure 139. Attaching Shields

ATTACHING REAR EXTENSION

Fasten rear extension to shield using 3/8 x 1" hex bolts, flat washers and serrated flanged nuts.

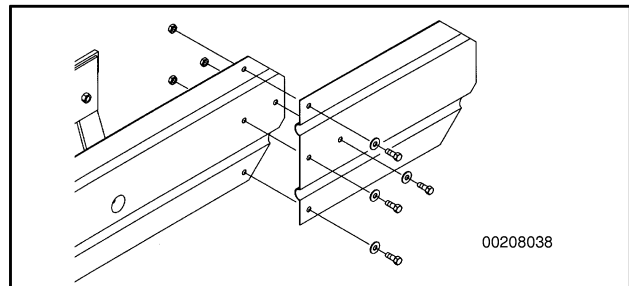

Figure 140. Attaching Rear Extension

Dual Disc / Dual Knife

FASTEN FLIP UP DISC TUBE (MODEL 2130, 2040)

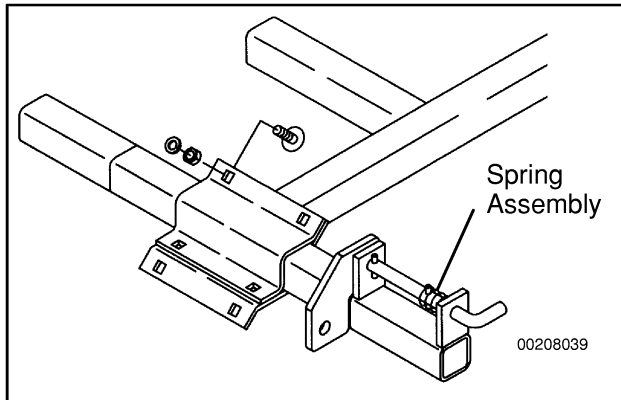

Figure 141. Flip-Up Disc Tube

Fasten tube assembly to front tube bracket using front tube clamp, 7/16 x 1-1/2" carriage bolts, lockwashers and hex nuts.

NOTE: Be sure tube is centered and spring assembly is on top. Spring assembly should always be on left side of tree.

FASTEN CLAMP ASSEMBLY

Fasten clamp assembly to front tube using the hardware provided with clamp assembly. Mount clamps on the back side of front tube as shown.

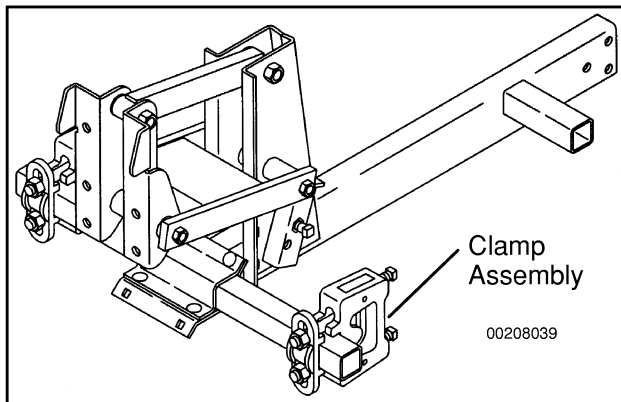

Figure 142. Fastening Clamp

ATTACH SHANK WELDMENT

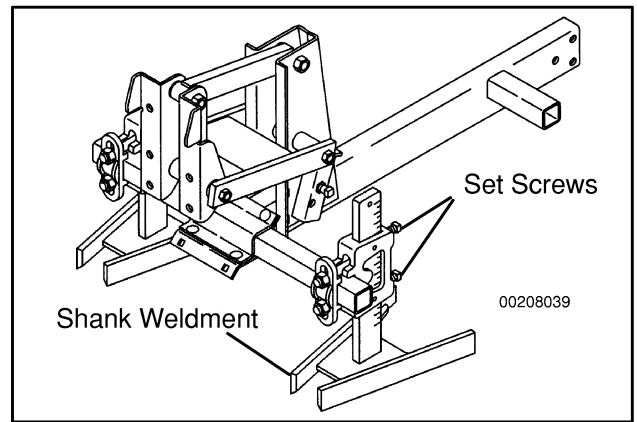

Figure 143. Attaching Shank Weldment

Slide shank weldment into clamp assembly. Adjust shank to proper height and tighten set screws in clamp assembly.

FASTEN DUAL DISC ASSEMBLY

Slide dual disc assemblies over the rail on shank weldment. Adjust to proper width and tighten hex bolt and jam nut on top of disc assembly. There are left and right disc assemblies. When mounted, the back of disc should be farther away from rail than the front to throw dirt away from the row.

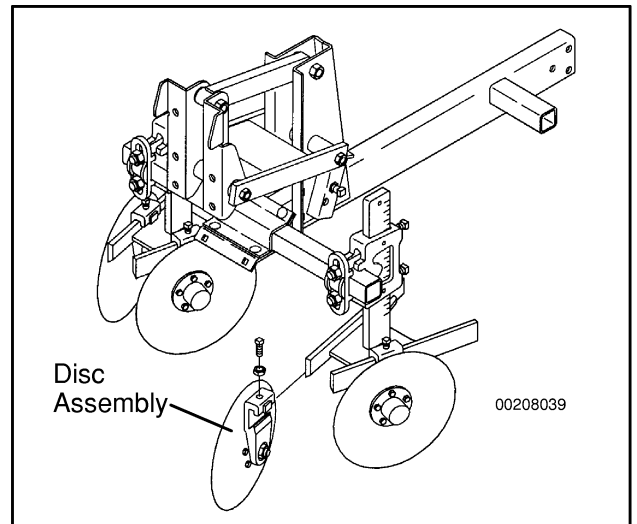

Figure 144. Fastening Disc Assembly

ATTACHING DUAL KNIFE

Fasten the knife to the adapter using two 3/8 x 1-1/2" carriage bolts, flat washers, lockwashers and hex nuts. (Knife must go on inside of adapter.)

Slide dual knife assemblies over the rail on shank weldment and fasten with 1/2" hex bolt and jam nut.

Note: The mounting surface of left and right knife adapters must be parallel to the row.

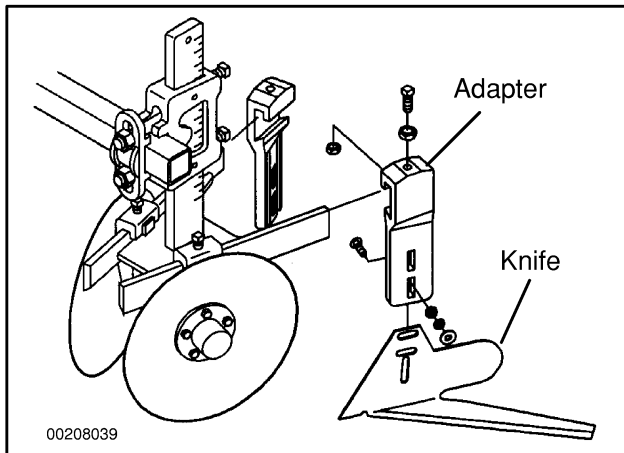

Figure 145. Dual Knife

Adjustable Screw Kit

Fasten adjustment nut to the shank weldment using a 3/8 x 1-1/2" hex bolt and serrated flanged nut. Thread the 5/8 x 4-1/2" square head set screw or crank into adjustment nut.

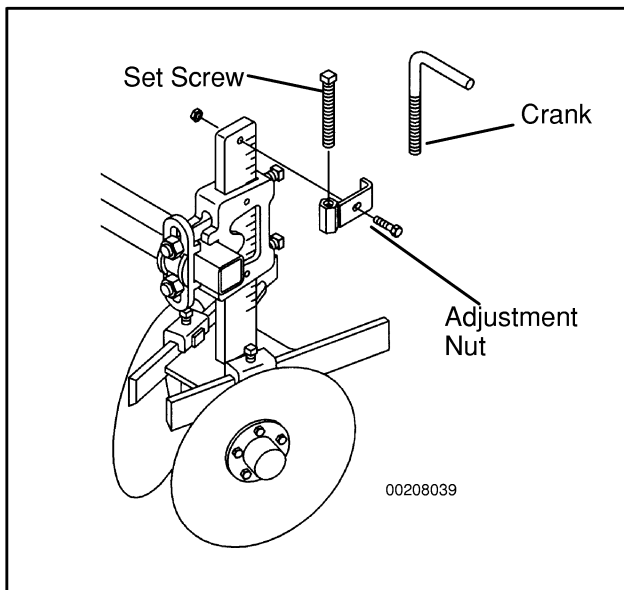

Figure 146. Adjustable Screw Kit

Mounting Round Shank Discs

Fasten clamp assembly to front tube using the hardware provided with the clamp assembly. Mount the clamps on the back side of front tube as shown.

Slide shank into slot in clamp assembly. Adjust shank to proper height and desired pitch, tighten set screws in clamp assembly.

Slide dual disc assemblies over the rail on shank weldment. Adjust to proper width and tighten hex bolt and jam nut on top of disc assembly. There are left and right disc assemblies. When mounted, the back of disc should be farther away from rail than the front to throw dirt away from the row.

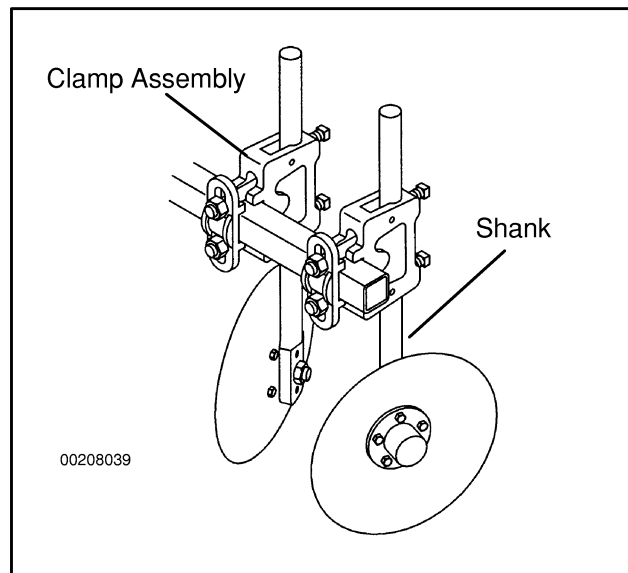

Figure 147. Mounting Discs

Mounting Round Shank Knives

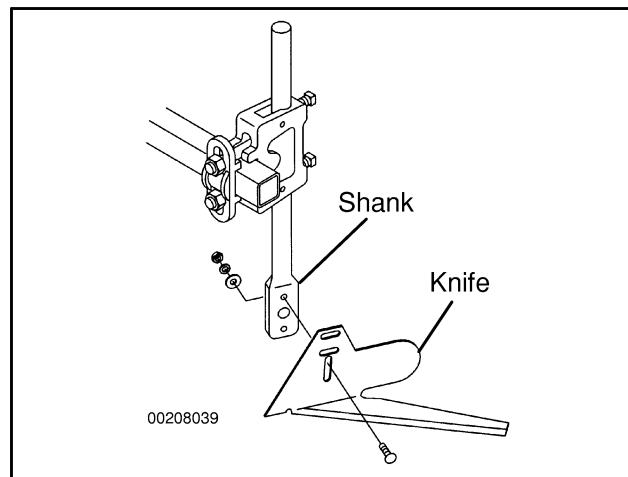

Figure 148. Mounting Knives

Fasten clamp assembly to front tube using the hardware provided with the clamp assembly. Mount the clamps on the back side of front tube as shown.

Slide shank into slot in clamp assembly. Adjust shank to proper height and desired pitch, tighten set screws in clamp assembly.

Fasten knife using two 3/8 x 1-1/2" carriage bolts, flat washers, lockwashers and hex nut.

Row Weeder Discs

Typically used to remove weeds next to the row. Can be reversed to move dirt to the row.

FASTEN TUBES TO TREE

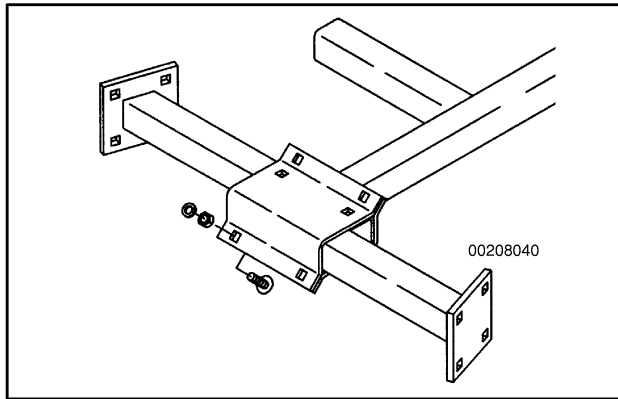

Figure 149. Fastening Tubes to Tree

Place front tubes on tree with plates facing as shown and fasten using 7/16 x 1-1/2" carriage bolts and serrated flanged nuts.

FASTEN DISC ASSEMBLIES TO TUBES

Fasten shank and disc assembly to tubes using back plate, 1/2 x 2-1/2" carriage bolts and serrated flanged nuts.

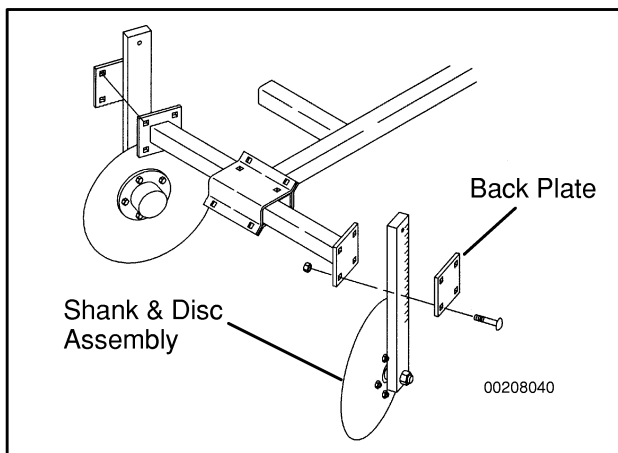

Figure 150. Mounting Discs

Row Weeder Disc Crank

CRANK ASSEMBLY

Thread crank through adjustment nut and fasten 5/8" jam nut and 5/8" serrated flanged nut on end. Be sure the nuts are jammed together.

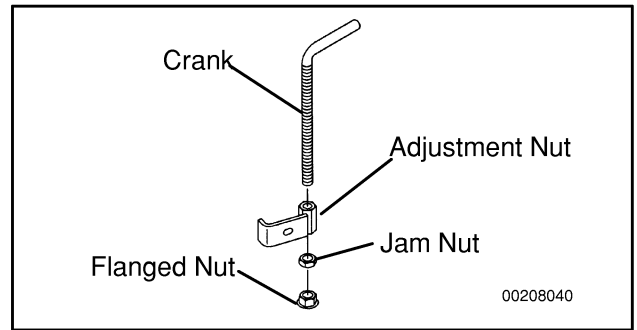

Figure 151. Disc Crank

MOUNTING CRANK ASSEMBLY

Fasten crank assembly to shank using 3/8 x 1-3/4" hex bolt and serrated flanged nut.

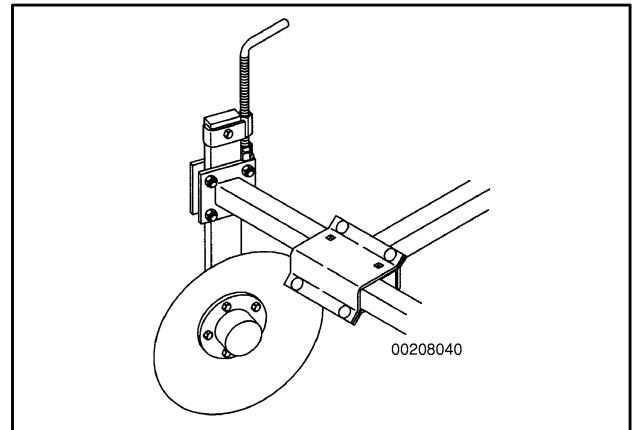

Figure 152. Mounting Crank Assembly

Hiller Attachment

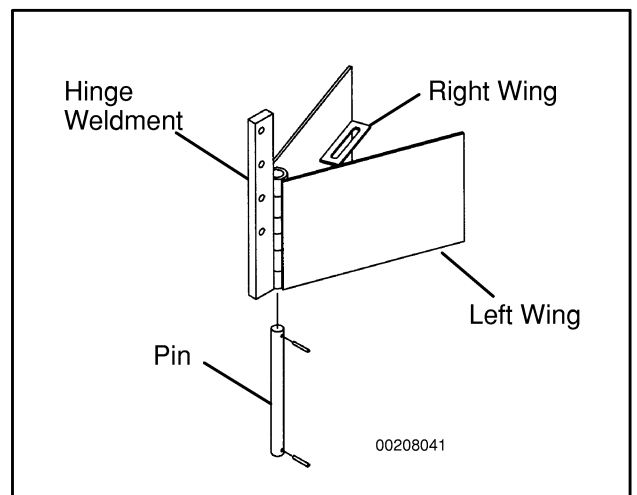

Figure 153. Assembling Hiller

Attach wing weldments and hinge together using pin and two 3/16 x 1-1/4" roll pins.

Place wings to desired width and fasten strap using 3/8 x 3/4" hex bolts and serrated flanged nuts.

Fasten side plates and spacer plates to hinge weldment using 3/8 x 2" hex bolts and serrated flanged nuts on shank mounted hillers, or 3/8 x 1-1/2" hex bolts and serrated flanged nuts on straight edge tine-mounted hillers. There are no spacer plates on straight edge tine-mounted hillers.

NOTE: Place point of side plates facing down on straight edge tine-mounted hillers.

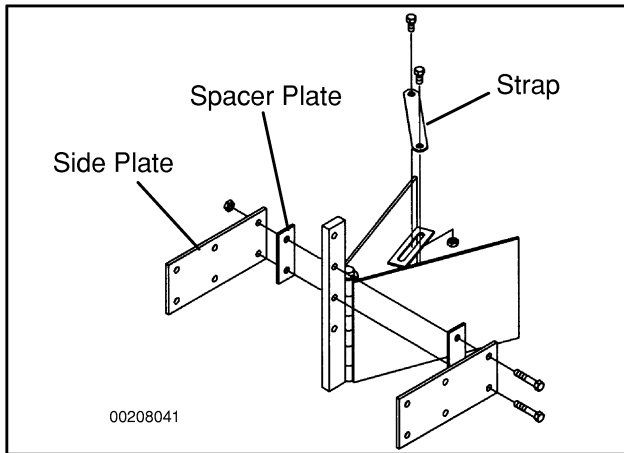

Figure 154. Assembling Side Plates to Hiller

FASTEN TO STRAIGHT EDGE TINE

Fasten to tine using four 3/8 x 1-1/2" hex bolts and serrated flanged nuts.

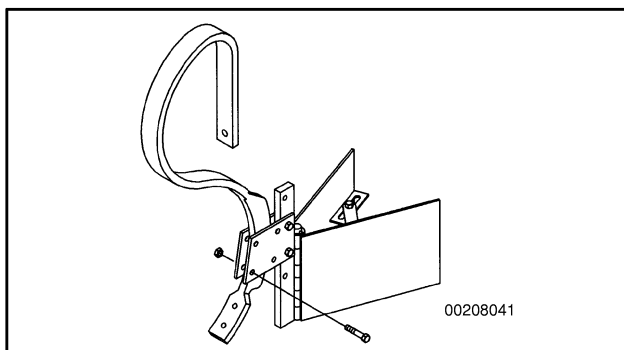

Figure 155. Fastening to Straight Edge Tine

FASTEN TO SHANK

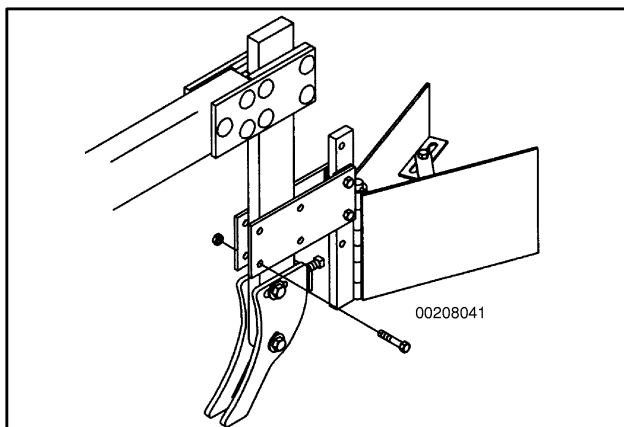

Figure 156. Fastening to Shank

Fasten to shank using 3/8 x 2" hex bolts and serrated flanged nuts.

Anhydrous Attachment (Model 3030)

FASTEN REAR EXTENSION

Fasten rear extension to rear tine bracket using four 3/8 x 1" hex bolts and serrated flanged nuts.

Fasten tine clamp to rear extension using four 1/2 x 2" hex bolts and serrated flanged nuts.

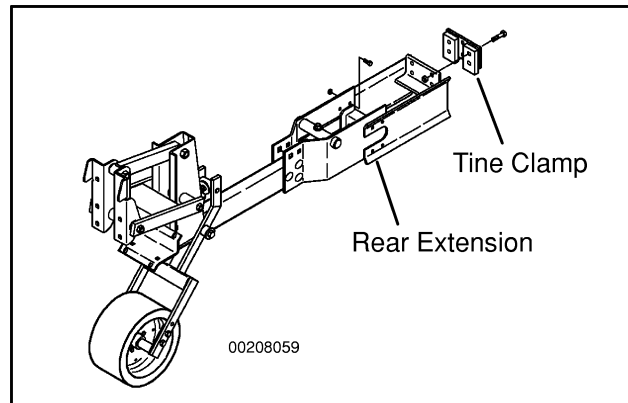

Figure 157. Fastening Rear Extension

FASTEN TINE AND KNIFE

Slide tine into tine clamp and secure with two 1/2 x 1" hex bolts and serrated flanged nuts. Fasten knife to tine using two 1/2 x 1-3/4" hex bolts and serrated flanged nuts.

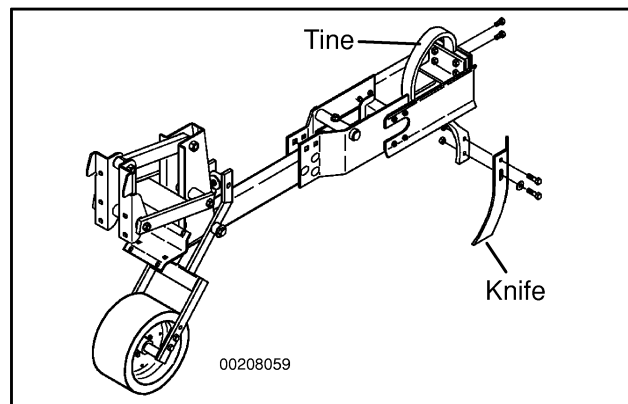

Figure 158. Fastening to Straight Edge Tine

Row Guide

Fasten clamp assembly to rear tube on tree using hardware provided with clamp. Slide row guide shank into clamp assembly and fasten with set screws on clamp assembly. Fasten cleanout wings to shank using 3/8 x 2" hex bolt and serrated flanged nuts.

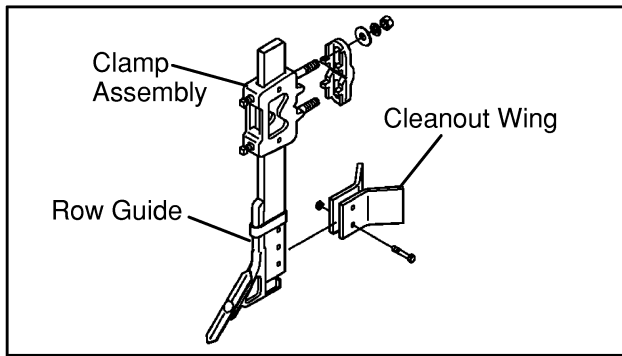

Figure 159. Row Guide

Spider Mount

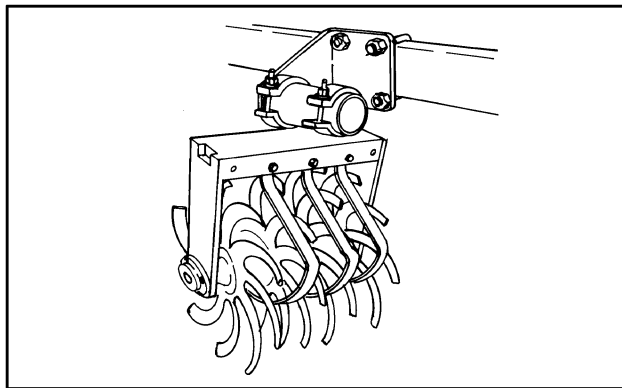

Figure 160. Spider Mounts

Fasten spider mount to tree using 1/2" U-bolts and serrated flanged nuts. Alloway does not supply spider wheel assembly.

Lift Assist (Light-Duty)

This lift assist is to be mounted on single beam 12 row or narrower units.

FASTEN TO TOOLBAR

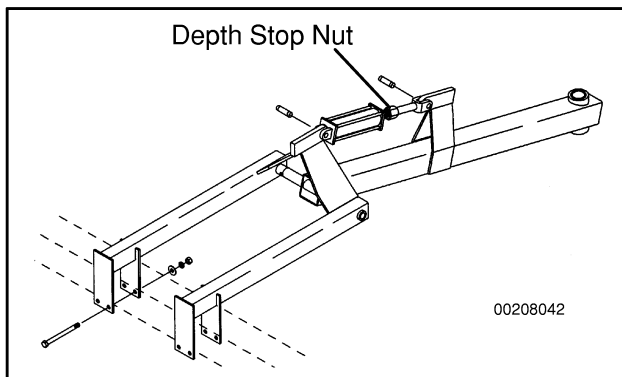

Figure 161. Fastening to Toolbar

Fasten frame assembly to toolbar using 3/4 x 9" hex bolts, flat washers, lockwashers and hex nuts.

Remove clevis from rod end of hydraulic cylinder and attach depth stop nut. Replace clevis.

Fasten hydraulic cylinder to ears on frame and fasten using pins provided with cylinder.

FASTEN CASTER ASSEMBLY

Remove cap, 1/2 x 1" hex bolt and lockwasher from top of caster assembly, slide assembly through bushings in frame assembly, fasten using cap, bolt and locknut.

Place decal on tube in position shown.

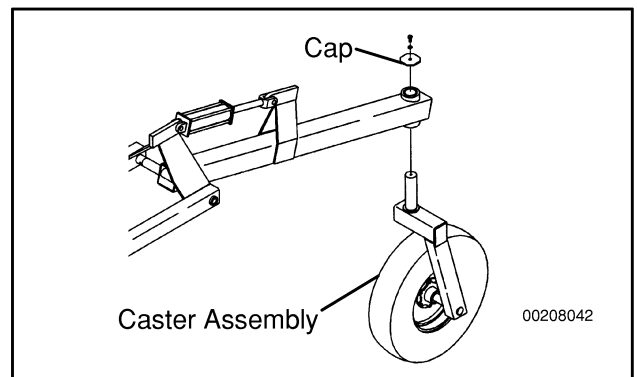

Figure 162. Fastening Caster Assembly

MOUNTING HYDRAULICS

Fasten 3/4-16 MORB x 1/2 FPT elbow to hydraulic cylinder. Attach hoses to elbows and 1/2" swivel restrictor to other end of hose.

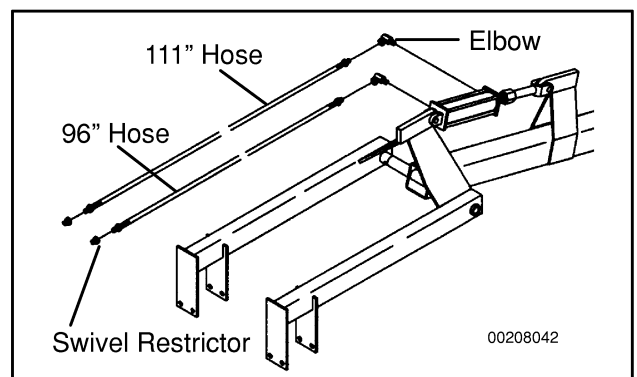

Figure 163. Mounting Hydraulics

Lift Assist (Heavy-Duty)

FASTEN TO TOOLBAR

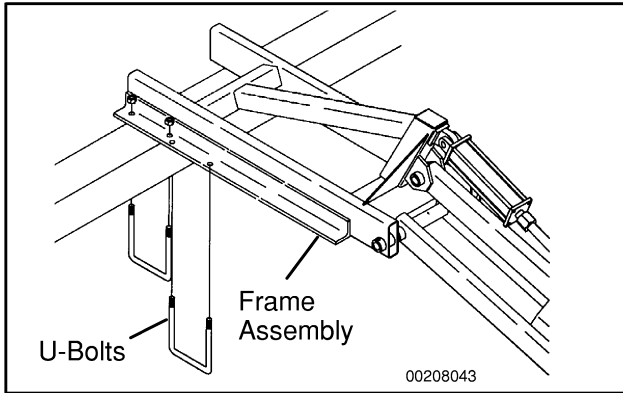

Figure 164. Fastening to Toolbar

Fasten frame assembly to toolbar using 3/4" U-bolts, lockwashers and hex nuts. On double toolbar, mount as shown; On single beam, mount to toolbar using front set of holes in lift assist frame, or you may use rear set of holes and cut off excess frame.

FASTEN HYDRAULIC CYLINDER

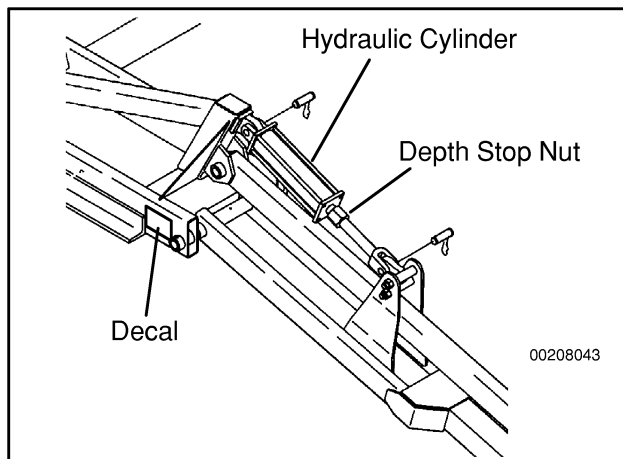

Figure 165. Fastening Cylinder

Remove clevis from rod end of hydraulic cylinder and attach depth stop nut. Replace clevis.

Fasten hydraulic cylinder to ears on frame and fasten using pins provided with cylinder.

Place warning decal on tube in position shown.

FASTEN CASTER ASSEMBLY

Remove cap, 1/2 x 1" hex bolt and lockwasher from top of caster assembly. Slide assembly through bushings in frame assembly and fasten using cap, bolt and lockwasher.

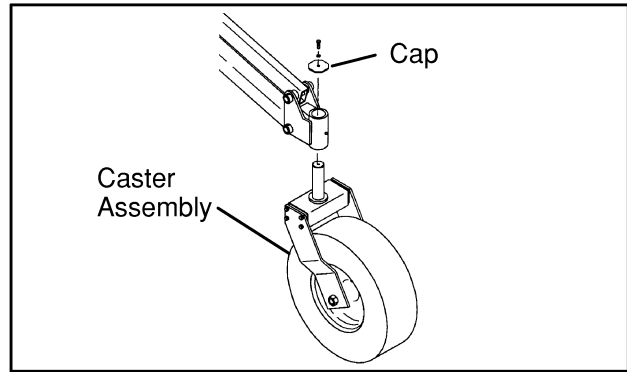

Figure 166. Fastening Caster Assembly

MOUNTING HYDRAULICS

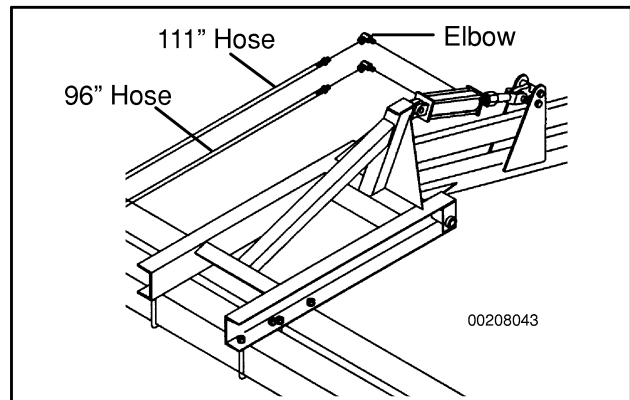

Figure 167. Mounting Hydraulics

Fasten 3/4-16 MORB x 1/2 FPT elbow to hydraulic cylinder. Attach hydraulic hoses to elbows and 1/2" swivel restrictor to other end of hose.

When using double lift assist, run 134" hose and 122" hose up to cylinder. Longer hoses go to rod end ports.

Run hoses to center of toolbar and fasten tees to hoses. Fasten 1/2" swivel restrictor to tees and 60" hose to restrictors.

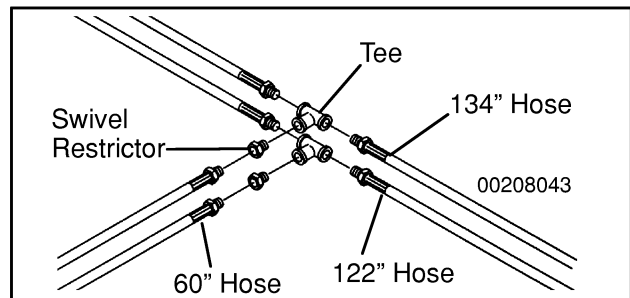

Figure 168. Mounting Hydraulics

Spray Fender Shields

Fasten linkage assembly to toolbar using 5/8" U-bolts and flanged nuts.

Fasten spring to linkage assembly in location shown. When installing the spring, make sure the spacer tube weldment that the spring hooks to is positioned so that on one end of the spring, the spacer tube weldment is on the left side of the spring hook and on the opposite end, it is to the right side of the spring hook. This will keep the spring centered on the linkage assembly. Note that the spring can be mounted in many positions that will allow it to "float" on ground or down pressure can be added. Undue wear will occur to the skids and shoes on bottom of shield if too much downward pressure is applied. (Pins are shown in most common location.)

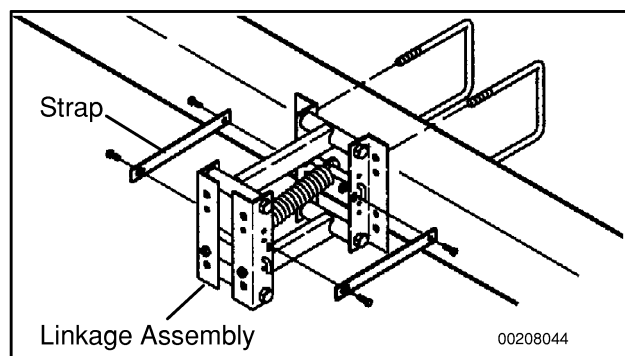

Figure 169. Fastening to Toolbar

Attach straps to linkage assembly using 3/8 x 1" hex bolts and flanged nuts

Attach tree assembly to linkage assembly using nuts on linkage assembly. Tighten nuts securely.

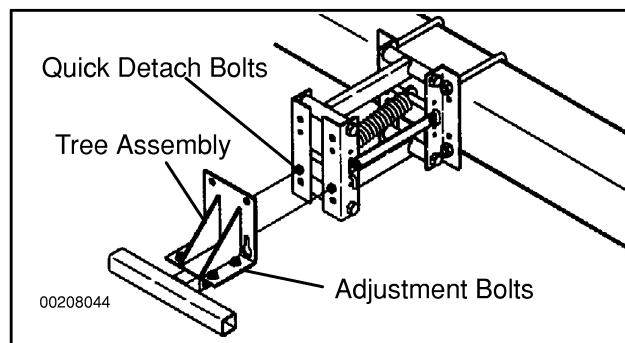

Figure 170. Attaching Tree Assembly

Fasten tube weldment to tree assembly using 1/2 x 2 x 3-1/2" long U-bolts, flat washers, lockwashers and hex nuts.

Fasten shield to tube weldment using two 3/8 x 1-3/4" carriage bolts on bottom and one 3/8 x 1-3/4" hex bolt on top with serrated flanged nuts.

Fasten skid to shield using 3/8 x 1" carriage bolts and flanged nuts.

Fasten shoe to shield using 3/8 x 1" carriage bolt in lower hole from mounting skid and 3/8 x 1 hex bolt in upper hole with flat washer and serrated flanged nut.

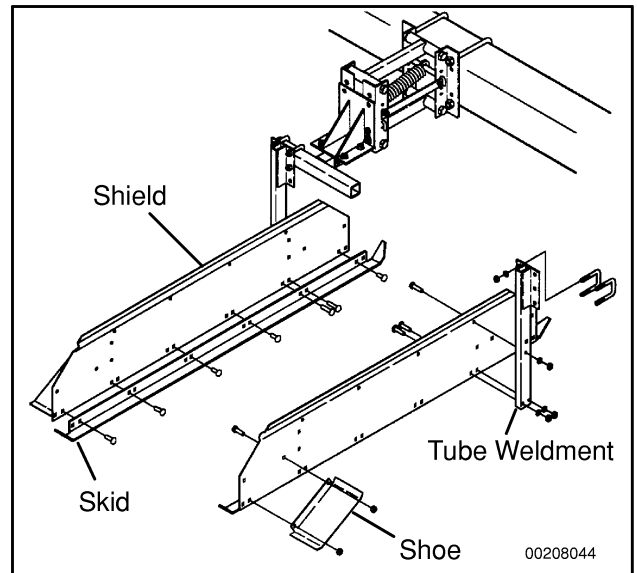

Figure 171. Mounting Shields

Mount angles to shields using 3/8 NC x 1" hex bolts, flat washers and flanged nuts.

Attach square tube to top of angles using two square tube mounting clamps, 3/8 x 1" hex bolts, flat washers and serrated flanged nuts.

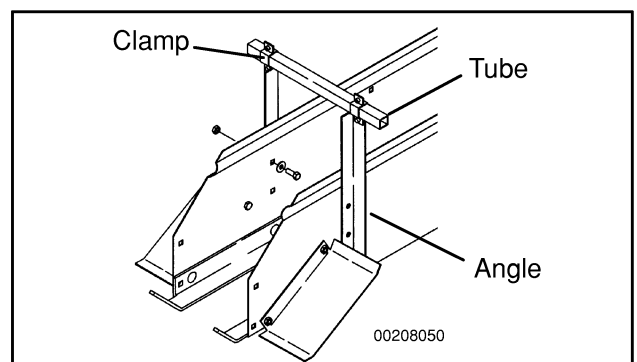

Figure 172. Mounting Supports

Slip pivot bracket on rear mounting bracket and tighten with 3/8 x 3/4" hex bolt. Assemble yellow cap, Q.J. body, elbow weldment and hose barb fitting together. Attach this assembly to pivot bracket using 3/8" flanged nuts. Then fasten the entire assembly to the inside rear hole in skid using 3/8 x 1" hex bolt and flanged nut.

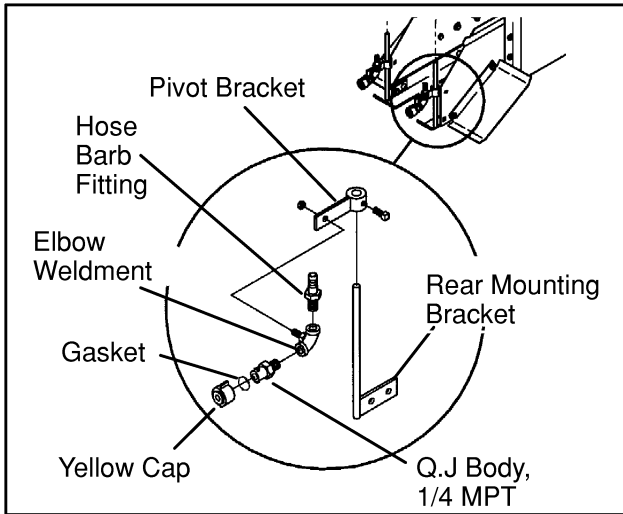

Figure 173. Rear Spray Bracket

Attach tee weldment to cross tube using nut provided. Attach three hose barb fittings to tee weld.

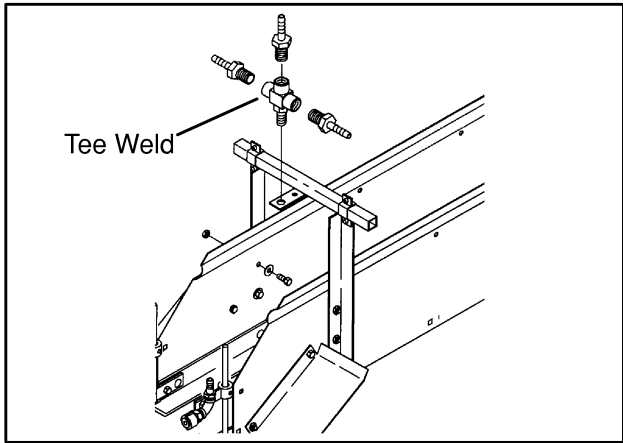

Figure 174. Top Spray Bracket

Run hoses as shown in dotted lines. Fasten hoses using hose clamps.

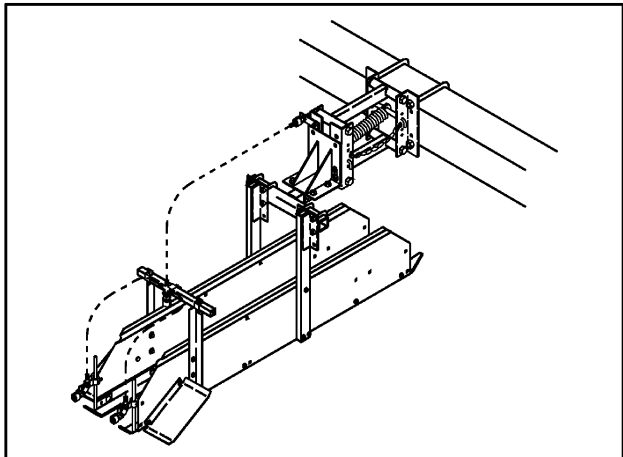

Figure 175. Hoses

MOUNTING OFFSET BRACKET

Used to mount spray fender over hinges on folding beams.

Remove U-bolts from linkages. Fasten offset bracket and spacer plate to toolbar using U-bolts and serrated flanged nuts. Fasten linkage assembly to offset bracket using 5/8 x 1-1/2" hex bolts and serrated flanged nuts.

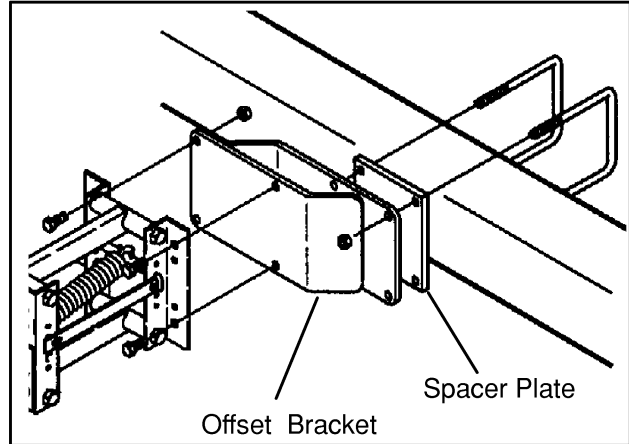

Figure 176. Mounting Offset Bracket

PLUMBING TOOLBAR

Fasten 1/2" hoses to tees and elbows using 1/2" wire clamps. Fasten 3/4" hose to tee using worm gear clamp. When assembly is complete, fasten hoses to toolbar and linkages using plastic cable ties.

Example in diagram is 4 row sprayer.

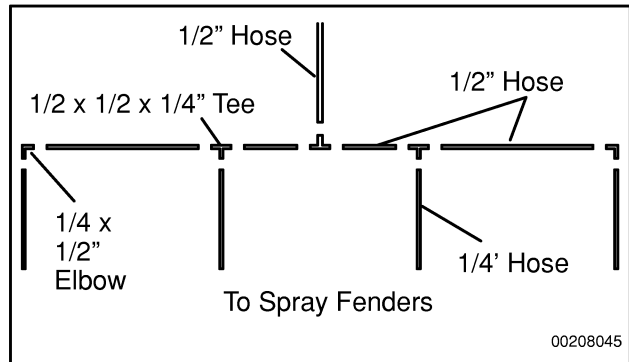

Figure 177. Plumbing Toolbar

Lay By Nozzle Attachment

Slide pipe through pivot bracket and fasten together using set screw. Fasten swivel nozzle body to pipe and yellow cap to swivel nozzle body.

Fasten hose to pipe using wire clamp. Slide hose shank into round hole cap and fasten to hose using worm gear clamp.

Fasten this assembly to back of tree on rigid shank.

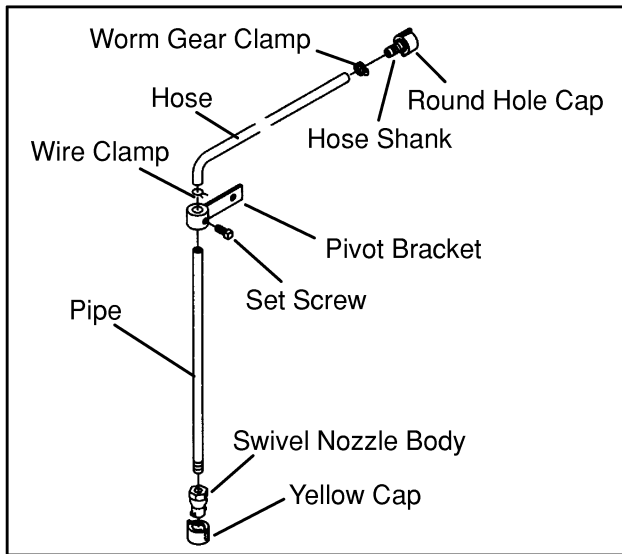

Figure 178. Lay By Nozzle Attachment

Down Pressure Springs

Fasten bracket weldment to upright using bolts holding pivot tube.

Fasten mounting plate to linkage using U-bolts and serrated flanged nuts on linkage assembly. Place springs into the holes at end of mounting plate.

Slide spring into place with washer on each end and fasten into place with cotter pins.

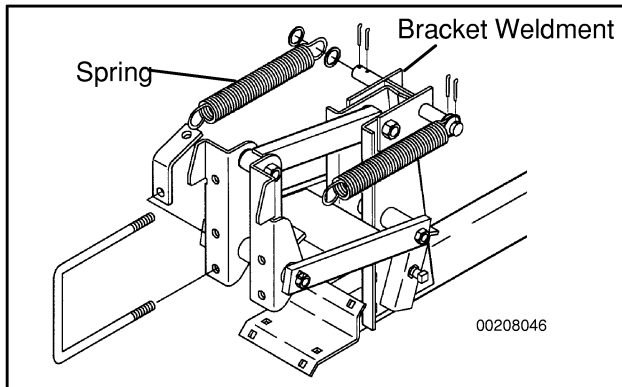

Figure 179. Down Pressure Springs

Down Pressure Springs (3030)

Slide spring into place with washer on each end and fasten into place with spring retainers.

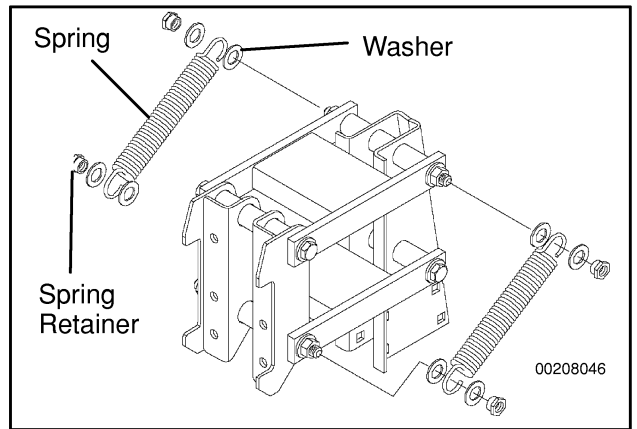

Figure 180. Down Pressure Springs - Model 3030

Vegetable Gang

On single row narrow cultivators, you get 1 pair discs, 1 pair standard knives and 2 gauge wheels.

On double row narrow cultivators, you get 2 pair discs, 2 pair standard knives and 1 gauge wheel.

The above can be attached to the tool carrying frame at locations to fit your needs.

Note: For very wide beds (80") you can bolt two of the above gang assemblies together. The bolts to attach together go through the tool carrying frames and then you would have a double wide frame carried by two parallel linkages on each wide bed. Extra knives or standard S-tines can be added to suit your needs.

Never attach large soil engaging tools such as furrowing shovels to these tool carrying frames. The furrows should be tilled and reshaped using a separate furrow gang with tines and furrowing shank.

MOUNTING TREE

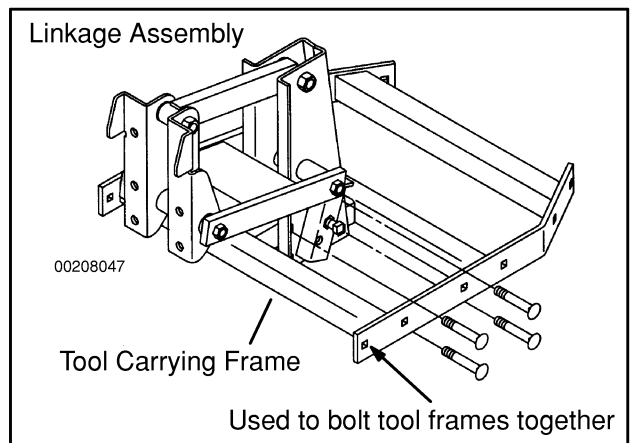

Figure 181. Mounting Tree

Fasten tree to linkage assembly using four 5/8 x 3-1/2" carriage bolts, lockwashers and hex nuts.

ASSEMBLING GAUGE WHEELS

Fasten wheel holder to gauge arm using two 3/8 x 1-1/4" hex bolts, lockwashers and hex nuts.

Fasten tire assembly to gauge arm assembly using 3/8 x 3/4" square head set screw with jam nut.

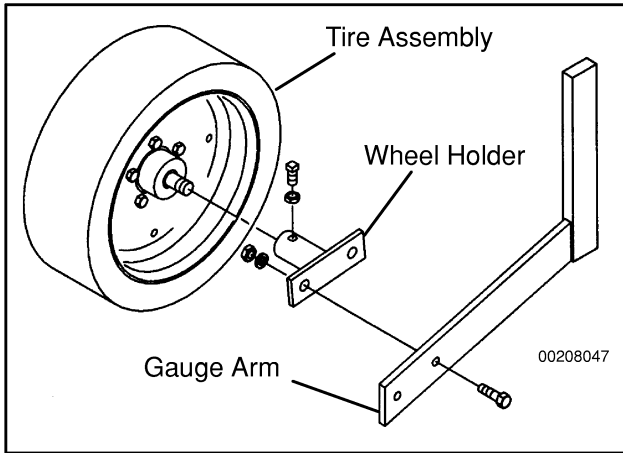

Figure 182. Assembling Gauge Wheel

MOUNTING GAUGE WHEEL ASSEMBLY

Fasten clamp to tree using back strap and 5/8 x 2-1/2" hex bolts in clamp assembly. Fasten gauge wheel assembly to clamp assembly using set screw.

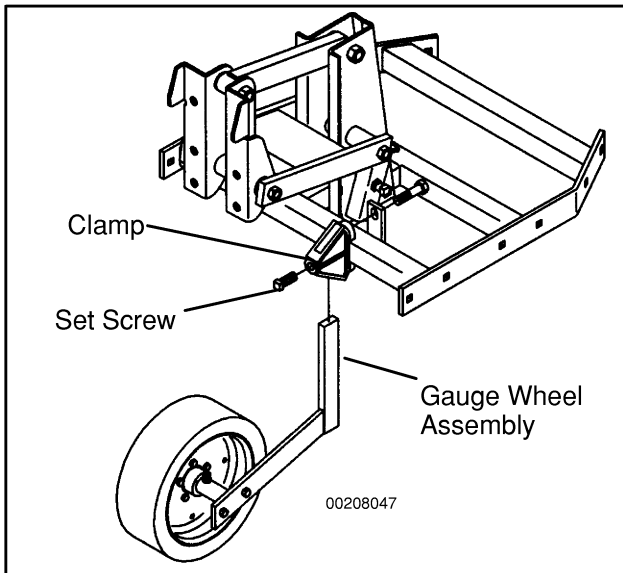

Figure 183. Mounting Gauge Wheel Assembly

MOUNTING DISCS

Fasten disc assembly to disc shank using 3/4" jam nut on back of disc assembly. The serrated washer goes between shank and disc assembly.

Fasten disc and shank assembly to clamp using 5/8 x 1-1/2" square head set screw in clamp assembly.

Fasten clamp to tree using back strap and 5/8 x 2-1/2" hex bolts in clamp assembly.

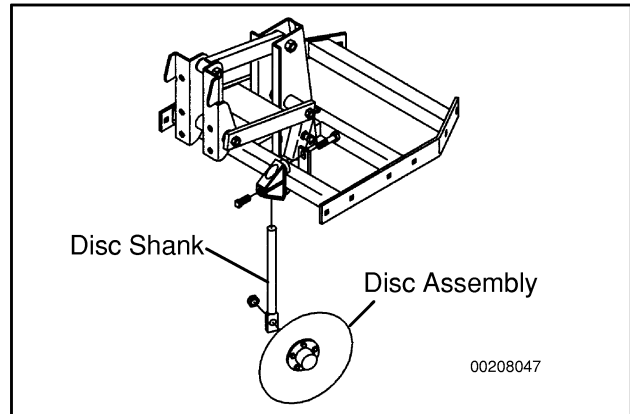

Figure 184. Mounting Discs

MOUNTING KNIVES

Fasten knife to standard shank using 1/2 x 1-1/4" carriage bolts, 1/2" lockwashers and hex nuts.

Fasten knife and standard shank assembly to clamp using 5/8 x 1-1/2" square head set screw in clamp assembly.

Fasten clamp to tree using back strap and 5/8 x 2-1/2" hex bolts in clamp assembly.

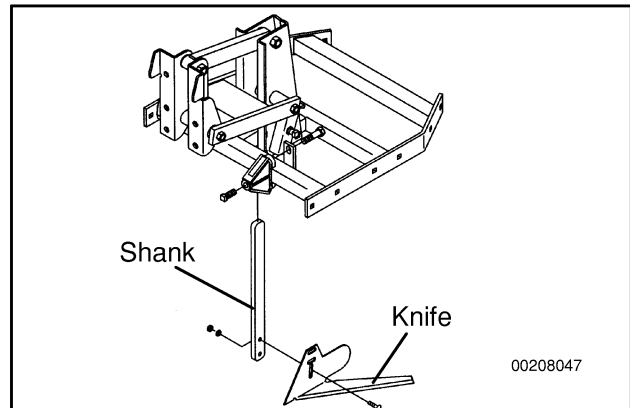

Figure 185. Mounting Knives

Double "H" Linkage

Remove parallel tube from linkage assembly and discard bolts. Press the four flanged bushings into the other parallel tube.

Bolt all the components together with 5/8" long bushings on outside and 2" long bushings on inside as shown.

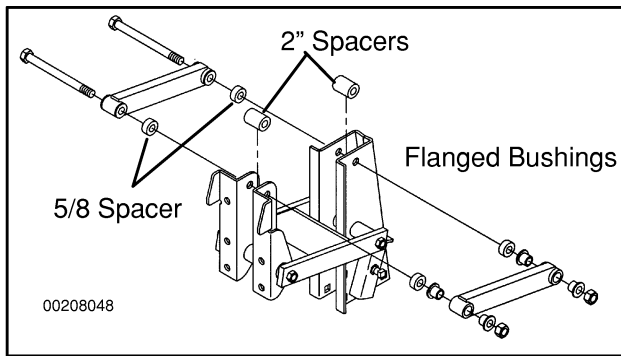

Figure 186. Double H Linkage

Anhydrous Tank Hitch

Center hitch mounts on toolbar and bolt on with four 3/4 x 9-1/2" hex bolts, flat washers, lockwashers and hex nuts.

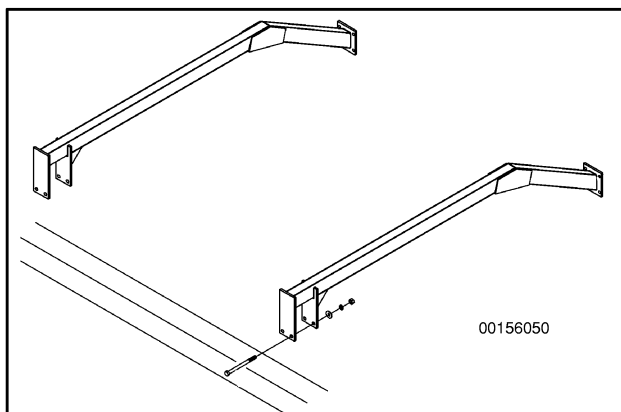

Figure 187. Mounting Hitch Mounts

Fasten cross tube to hitch mounts with four U-bolts and spiral lock flange nuts.

Bolt on rear hitch to cross tube using U-bolts and spiral lock flange nuts.

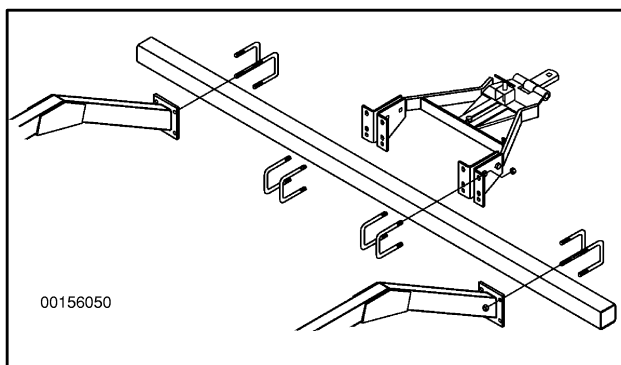

Figure 188. Mounting Hitch

Complete the Pre-Delivery and Delivery Check Lists on page 26 before delivering equipment to customer.

NOTES

INDEX TO PARTS LISTS

180° Fold Tool Bar	66–67
180° Fold Double & Single Reinforced Tool Bars	68–71
Rigid Tool Bars	72
3-Point Hitch — 3-Piece, 4-Piece	73
Linkage Components	74–75
Tines, Shovels & Sweeps	76–79
Spring Trip Shank (2065)	80
Tine Trees	81
Gauge Arms & Wheels	82–83
Rear Tine Brackets, Branches & Tubes	84–85
Dual Disc & Dual Knife Assembly	86–87
Model 3030 Components	88
Tool Bar Clamps	89
King Guide Strut Assembly	90
Vegetable Gang Components	91
Adjustable Guide Wheels	92–93
Semi-Pneumatic Guide Wheel & Steel Guide Wheel	94
Curved Arm Support Wheel	95
Yoke Arm Support Wheel	96
Stabilizer Coulter	97
Rear Stabilizer coulter	98–99
Anhydrous Hitch	100
Anhydrous Attachment	100
Row Guide Markers	101
Row Weeder Discs	102
Coulter Disc Components	103
Tunnel Shields	103
Guide Wheel, J-Shank	104
Toggle Trip	105
Lift Assist	106–111
Hiller Attachment	109
Mounts (Shields)	112
Parking Stand	113
Rolling Shields	114–115
End Shields & Open Top Shields	116
Spray Fender Spray Kit	117
Spray Fender Components	118–119
Hardware	120

180° FOLD TOOL BAR (F)

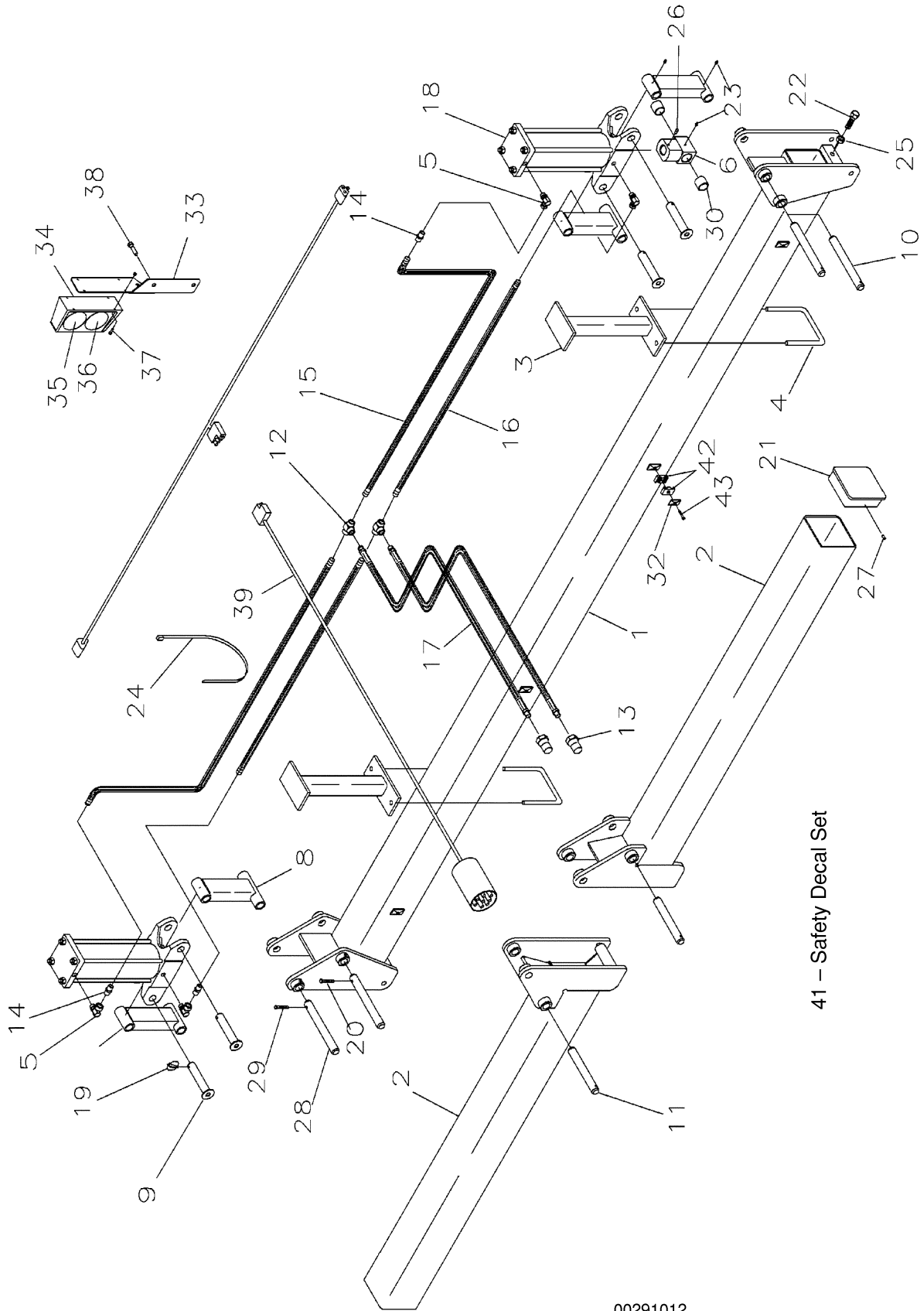

00291012

180° FOLD TOOL BAR (F)

REF.	PART NO.	DESCRIPTION	QTY.
1	20022066	Center Section, 142" (830)	1
	20022031	Center Section, 154" (1222)	1
	20022068	Center Section, 158" (1030)	1
	20022032	Center Section, 168" (1224)	1
	20022070	Center Section, 176" (1522)	1
	20022071	Center Section, 184" (836-840)	1
	20022072	Center Section, 198" (1622)	1
	20022073	Center Section, 202" (1230)	1
	20022074	Center Section, 242" (1822)	1
2	20021277	Wing Weld, 63-1/2" (830,1222,1224)	2
	20020413	Wing Weld, 72" (836-840, 640Skip)	2
	20021627	Wing Weld, 75" (1030)	2
	20021491	Wing Weld, 84" (1522)	2
	20020381	Wing Weld, 92" Bar (1230,1622,1822)	2
3	20020321	Wing Rest	2
4	20030344	5/8" U-Bolt, for 7 x 7 Beam	2
5	90503163	Elbow, 6 MJIC x 6 MJIC x 90 degree	4
6	20033324	Pin Eye Clevis	2
	20021776	Pin Eye Clevis Assembly, 1-1/2" ID	2
7	20020317	Cylinder Linkage, Wing	2
8	20020316	Cylinder Linkage, Center	2
9	20021317	Cylinder Pin, 6.63" Long	4
10	20030513	Cylinder Pin 1-1/4" x 11-1/4" Long	4
11	20030526	Pin 1-1/4 x 9-5/8" Long	2
12	90503112	Tee, 6 MJIC	2
13	90519126	Quick Coupler, Male Tip	2
14	90503162	6 JIC Flow Restrictor, 1/16"	4
15	90519119	3/8" Hose x 6 FJIC x 6 FJIC x 100"	2
	90519147	3/8" Hose x 6 FJIC x 6 FJIC x 111"	2
	90519121	3/8" Hose x 6 FJIC x 6 FJIC x 120"	2
	90519148	3/8" Hose x 6 FJIC x 6 FJIC x 142"	2
16	90519152	3/8" Hose x 6 FJIC x 6 FJIC x 82"	2
	90519119	3/8" Hose x 6 FJIC x 6 FJIC x 100"	2
	90519147	3/8" Hose x 6 FJIC x 6 FJIC x 111"	2
	90519151	3/8" Hose x 6 FJIC x 6 FJIC x 134"	2
17	90519146	3/8" Hose x 6 FJIC x 8 MORB x 60"	2
18	20020503	5 x 12 Cylinder Complete with Clevis	2
	20020500	5 x 12 Cylinder, Less Clevis	2
	90521263	Seal Kit, 5 x 12 Cylinder	
	90521382	5 x 12 Cylinder Rod (2' Rod 1-1/4" Thread)	
	90521383	5 x 12 Cylinder Rod Cap	
	90521384	5 x 12 Cylinder Cap	
19	90025010	1/4 x 1-1/4 Klic Pin	4
20	90001071	5/16 x 2-1/2 Hex Bolt GR5	4
21	20032636	Rubber Tube Cap, 7 x 7	2
22	90003024	3/4 NC x 2-1/2 Hex Bolt GR5, Full Thread	4
23	90515024	Zerk, 1/4-28 UNF Straight	10
24	90507086	32" Plastic Cable Tie	6
25	90006282	3/4 NC Jam Nut	4
26	90016033	3/4 NC x 1 Sq. Head Set Screw	2
27	90016897	#6 x 3/4 Pan Head Sheet Metal Screw	4
28	20033431	Hinge Pin, 1-1/2 x 11-1/4	2
29	90001125	3/8 x 3 Hex Bolt GR5	2
30	20033285	Garmax Bushing, 1-1/2" ID	
31	90003459	5/16" NC x 1-3/8 Long Hex Bolt GR5	5
32	90031068	Top Plate Hose Clamp	5
33	20033870	Light Bracket, RH (Shown)	1
	20033869	Light Bracket, LH (Not Shown)	1
34	90401150	Dual Tail Light, RH (Shown)	1
	90401149	Dual Tail Light, LH (Not Shown)	
35	90401145	Amber Tail Light	2
36	90401146	Red Tail Light	2
37	90001009	1/4 NC x 1 Hex Bolt GR5	8
38	90001337	5/8 NC x 1 Hex Bolt GR5	4
39	90401152	Wire Harness, Tractor Half	1
41	20013731	Safety decal set	1
42	90031069	Clamp Body	5
43	90001115	5/16 NC x 1-1/2 Hex Bolt GR5	5

180° FOLD DOUBLE & SINGLE REINFORCED TOOL BARS

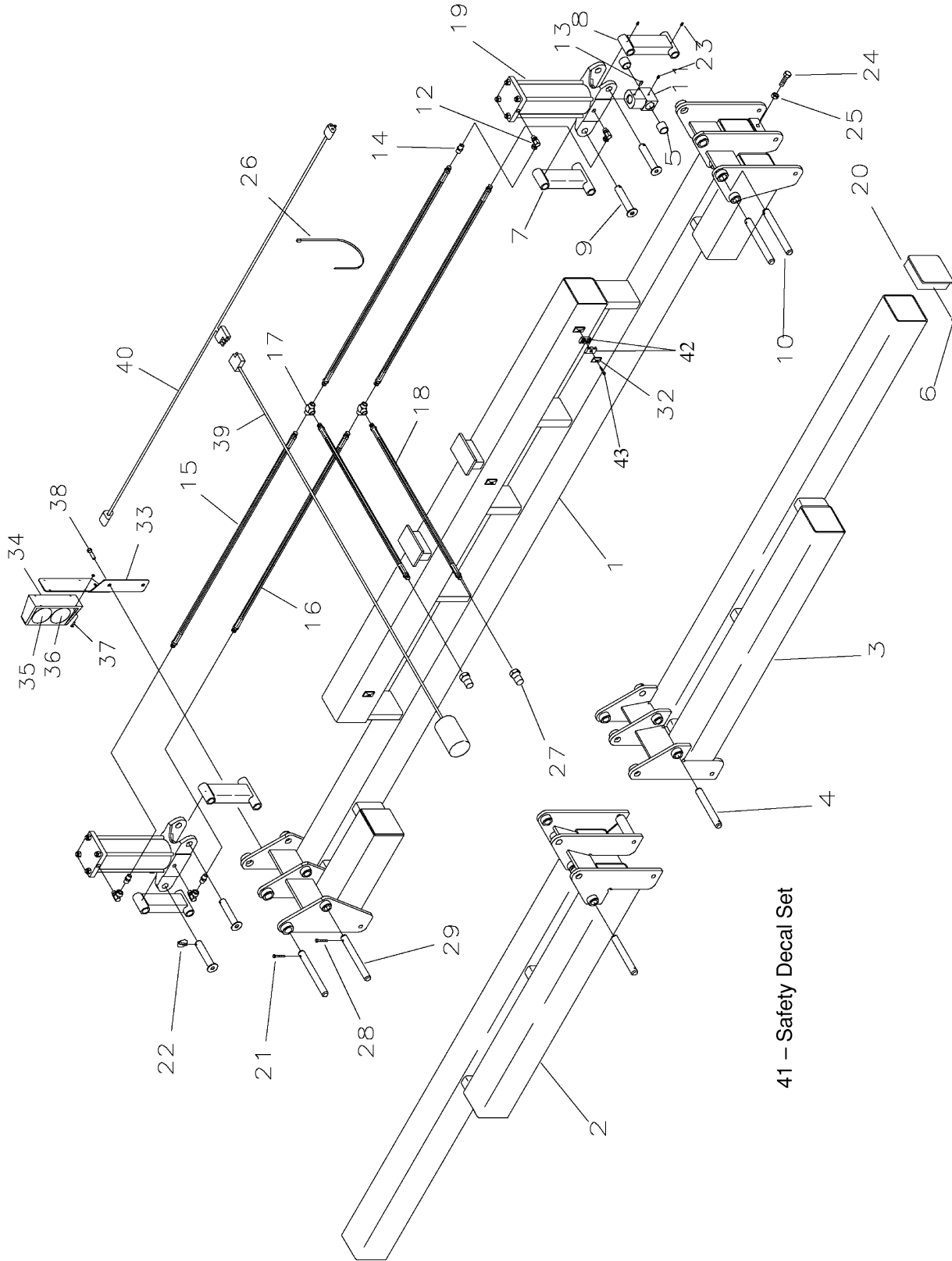

41 – Safety Decal Set

00156033

180° FOLD DOUBLE & SINGLE REINFORCED TOOL BARS

REF.	PART NO.	DESCRIPTION	QTY.
1	20022075	Double Center Section, 184" (836-840)	1
	20022076	Double Center Section, 198" (1622)	1
	20022077	Single Reinforced Center Section, 198" TRF (1622)	1
	20022078	Double Center Section, 206" (1228-1232)	1
	20022079	Single Reinforced Center Section, 206" TRF (1230)	1
	20022080	Single Reinforced Center Section, 242" TRF (1822)	1
	20022081	Double Center Section, 256" (1040 Skip)	1
	20022082	Single Reinforced Center Section, 264" TRF (1630)	1
	20022083	Double Center Section 242" (1822,1530)	1
	20022084	Double Center Section, 264" (1236-1240, 1630)	1
	20022085	Double Center Section, 286" (2422)	1
2	20021309	Right Wing, 72" (836-840)	1
	20021311	Right Wing, 92" (1228-1232, 1622, 1822)	1
	20021632	Right Wing, 110" (1530)	1
	20021313	Right Wing, 122" (1236-1240, 1630)	1
	20021629	Right Wing, 125" (1040 Skip)	1
	20021387	Right Wing, 127-1/2" (2422)	1
3	20021310	Left Wing, 72" (836-840)	1
	20021312	Left Wing, 92" (1228-1232, 1622, 1822)	1
	20021631	Left Wing, 110" (1530)	1
	20021314	Left Wing, 122" (1236-1240, 1630)	1
	20021630	Left Wing, 125" (1040 Skip)	1
	20021388	Left Wing, 127-1/2" (2422)	1
4	20032451	Hinge Pin 1-1/4" x 18-3/8" Long	2
5	20030344	5/8" U-Bolt, 7 x 7	2
6	20020321	Wing Rest	2
7	20020316	Cylinder Linkage, Center	2
8	20020317	Cylinder Linkage, Wings	2
9	20021317	Pin, Cylinder Linkage (5 x 12 Cylinder)	4
	20021611	Pin, Cylinder Linkage (6 x 12 Cylinder)	4
10	20032450	Hinge Pin, 1-1/4" x 19-3/4" Long	2
11	20033324	Pin Eye Clevis	2
	20021776	Pin Eye Clevis Assembly, 1-1/2" ID w/bushings	2
12	90503163	Elbow, 6JICM, 6JICM x 90 Deg.	4
13	90016033	3/8 NC x 1 Sq. Head Set Screw	2
14	90503162	6 JICM x 6JICM Flow Restrictor, 1/16"	4
15	90519147	3/8" Hose x 6 FJIC x 6 FJIC x 111"	2
	90519155	3/8" Hose x 6 FJIC x 6 FJIC x 120"	2
	90519148	3/8" Hose x 6 FJIC x 6 FJIC x 142"	2
	90519149	3/8" Hose x 6 FJIC x 6 FJIC x 152"	2
	90519150	3/8" Hose x 6 FJIC x 6 FJIC x 160"	2
	90519154	3/8" Hose x 6 FJIC x 8ORBM x 115"	2
16	90519150	3/8" Hose x 6 FJIC x 6 FJIC x 160"	2
	90519130	3/8" Hose x 6 FJIC x 6 FJIC x 96"	2
	90519147	3/8" Hose x 6 FJIC x 6 FJIC x 111"	2
	90519151	3/8" Hose x 6 FJIC x 6 FJIC x 134"	2
	90519148	3/8" Hose x 6 FJIC x 6 FJIC x 142"	2
	90519149	3/8" Hose x 6 FJIC x 6 FJIC x 152"	2

180° FOLD DOUBLE & SINGLE REINFORCED TOOL BARS

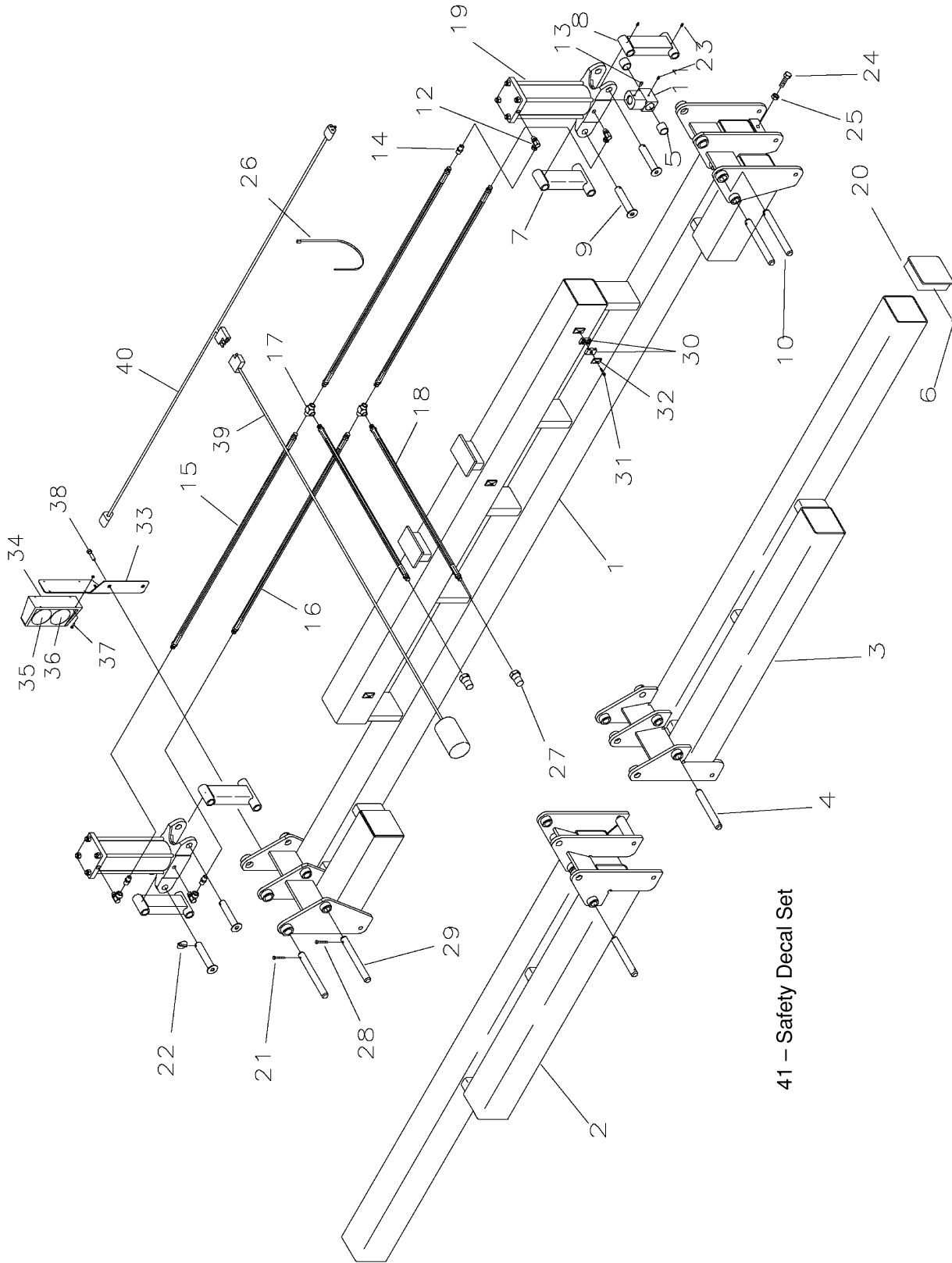

41 – Safety Decal Set

00156033

180° FOLD DOUBLE & SINGLE REINFORCED TOOL BARS

REF.	PART NO.	DESCRIPTION	QTY.
17	90503112	Tee, 6 MJIC	2
18	90519146	3/8" Hose x 6 FJIC x 8ORBM 60"	2
19	20020503	5 x 12 Cylinder Complete with Clevis	2
	20020500	5 x 12 Cylinder less Clevis	2
	9052263	Seal Kit, 5 x 12 Cylinder	1
	90521382	5 x 12 Cylinder Rod	1
	90521383	5 x 12 Cylinder Rod Cap	1
	90521384	5 x 12 Cylinder Cap	1
	20021564	6 x 12 Cylinder Complete with Clevis	1
	90521410	6 x 12 Cylinder less Clevis	1
	90521386	6 x 12 Cylinder Rod	1
	90521387	6 x 12 Cylinder Rod Cap	1
	90521388	6 x 12 Cylinder Cap	1
	90521368	Seal Kit, 6 x 12 Cylinder	1
	20021762	Clevis Assy. (1-1/4 Pin)	1
	90521385	1-1/4" Nut	1
20	20032636	Rubber Tube Caps, 7 x 7	4
21	90001071	5/16 x 2-1/2 Hex Bolt	6
22	90025010	1/4 x 1-1/4 Klic Pin	4
23	90515024	Zerk, 1/4-28 UNF, Straight	10
24	90003024	3/4 NC x 2-1/2 Hex Bolt	4
25	90006282	3/4 NC Jam Nut	4
26	90507086	32" Plastic Cable Ties	6
27	90519126	Quick Coupler, Male Tip	2
28	90001071	5/16 x 2-1/2 Hex Bolt (1-1/4 Hinge Pin)	2
	90001125	3/8 x 3 Hex Bolt (1-1/2" Hinge Pin)	2
29	20033170	Hinge Pin, 1-1/2" x 19-3/4" long	2
30	90016897	#6 x 3/4 Pan Head Sheet Metal Screw	4
31	20033285	1-1/2" Garmax Bushing	1
	20033355	1-1/4" Garmax Bushing	1
32	90031068	Top Plate Hose Clamp	5
33	20033870	Light Bracket, RH (Shown)	1
	20033869	Light Bracket, LH (Not Shown)	1
34	90401138	Dual Tail Light, RH (Shown)	1
	90401137	Dual Tail Light, LH (Not Shown)	1
35	90401145	Amber Tail Light	2
36	90401146	Red Tail Light	2
37	90001009	1/4 NC x 1 Hex Bolt GR5	8
38	90001337	5/8 NC x 1 Hex Bolt GR5	4
39	90401152	Wire Harness, Tractor Half	1
41	20013731	Safety decal set	1
42	90031069	Clamp Body	5
43	90001115	5/16 NC x 1-1/2 Hex Bolt GR5	5

RIGID TOOL BARS (TRR)

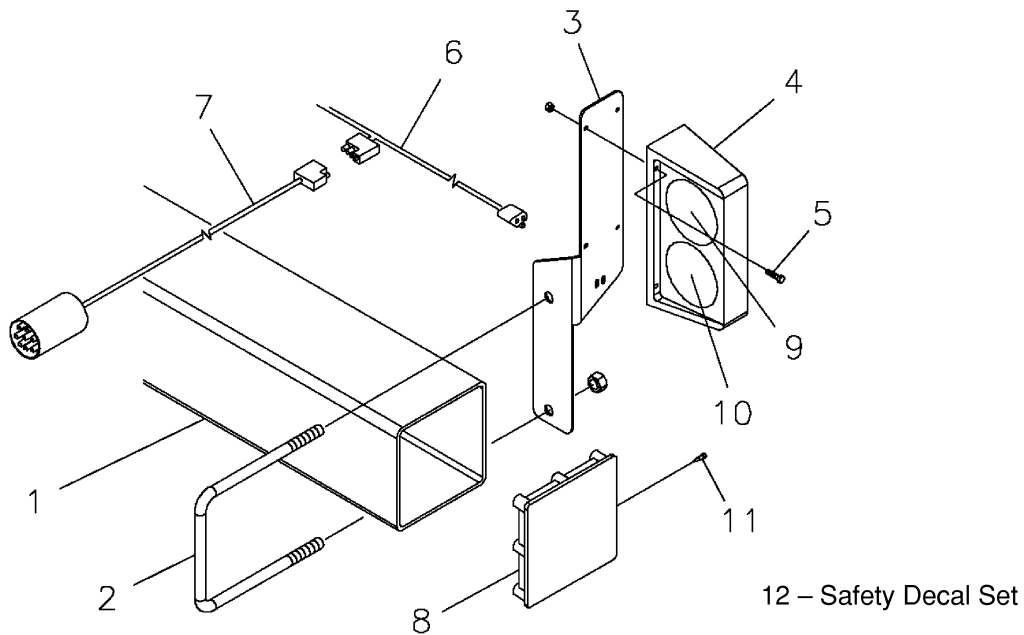

00291014

REF.	PART NO.	DESCRIPTION	QTY.
1	20022060	Toolbar, 7 x 7 x 1/4 x 152" Long, 4-30 -or-	1
	20022061	Toolbar, 7 x 7 x 1/4 x 200" Long, 4-60, 6-30 -or-	1
	20022062	Toolbar, 7 x 7 x 1/4 x 252" Long, 6-60, 8-30 -or-	1
	20022063	Toolbar, 7 x 7 x 1/4 x 288" Long, 12-22 -or-	1
	20022064	Toolbar, 7 x 7 x 1/4 x 300" Long, 6-row skip -or-	1
	20022065	Toolbar, 7 x 7 x 1/4 x 328" Long, 8-40 -or-	1
	20022086	Toolbar, 7 x 7 x 1/4 x 328" Long (TRR bar) -or-	1
	20022087	Toolbar, 7 x 7 x 1/4 x 372" Long (TRR bar)	1
2	20030344	U-Bolt, 5/8 NC x 7 x 8.5 Long	2
3	20033869	Light Bracket, LH (Shown)	1
	20033870	Light Bracket, RH (Not Shown)	1
4	90401149	Dual Tail Light, LH (Shown)	1
	90401150	Dual Tail Light, RH (Not Shown)	1
5	90001009	1/4 NC x 1 Hex Bolt GR5	4
6	90401152	Wire Harness	1
8	20032636	Rubber Tube Cap	2
9	90401145	Amber Tail Light	2
10	90401146	Red Tail Light	2
11	90016897	#6 x 3/4 Pan Head Sheet Metal Screw	2
12	20013730	Safety decal set	1

3-POINT HITCH — 3-PIECE, 4-PIECE

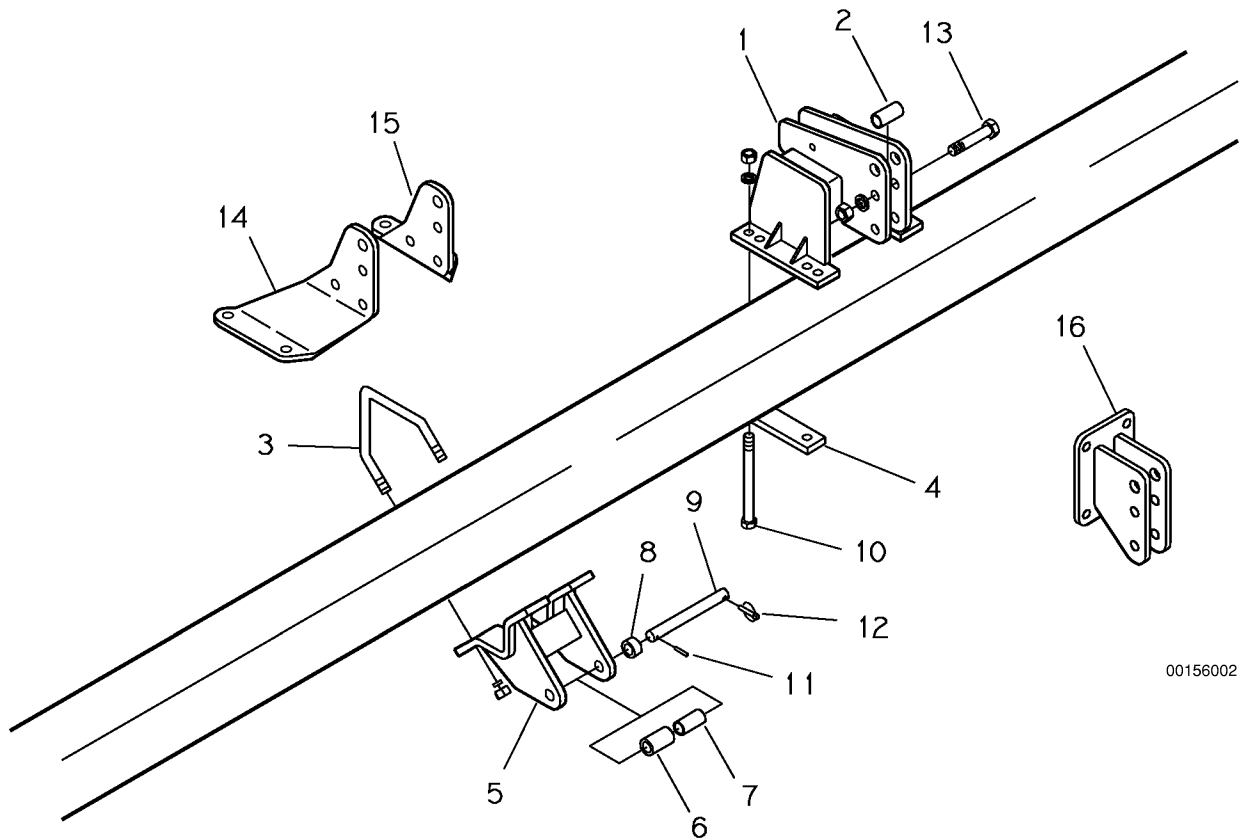

00156002

REF.	PART NO.	DESCRIPTION	QTY.
1	20020670	Upper Mast Bracket, 3 Piece (Heavy Duty)	1
2	20030151	Mast Spacer Bushing, 1 ID x 1-1/4 OD x 2-1/8 Long	2
3	20031443	A-Bolt, 7/8 x 7 x 7	4
4	20030970	Back Strap	2
5	20020554	Lower 3 Point Hitch (Right Side)	1
		-or-	
5	20022089	Lower 3 Point Hitch (Left Side, with Safety Decals)	1
6	20030959	Spacer, 1-3/4 OD	2
7	20030961	Bushing, 1-7/16 OD x 3 Long	2
8	20030960	Spacer, 1-3/4 OD x 1 Long	2
9	20030962	Pin	2
	20020553	Pin Assembly (Ref. 9 and 11)	2
10	90003039	7/8 NC x 10 Hex Bolt	4
11	90029204	Roll Pin, 5/16 x 1-5/8 Long	2
12	90025012	7/16 x 2 Klic Pin	2
13	90001531	1 NC x 5 Hex Bolt	2
14	20030964	Upper Mast Plate, Right (4 Piece)	1
15	20030963	Upper Mast Plate, Left (4 Piece)	1
16	20021793	Upper Mast Bracket (TRF Toolbars)	1

LINKAGE COMPONENTS

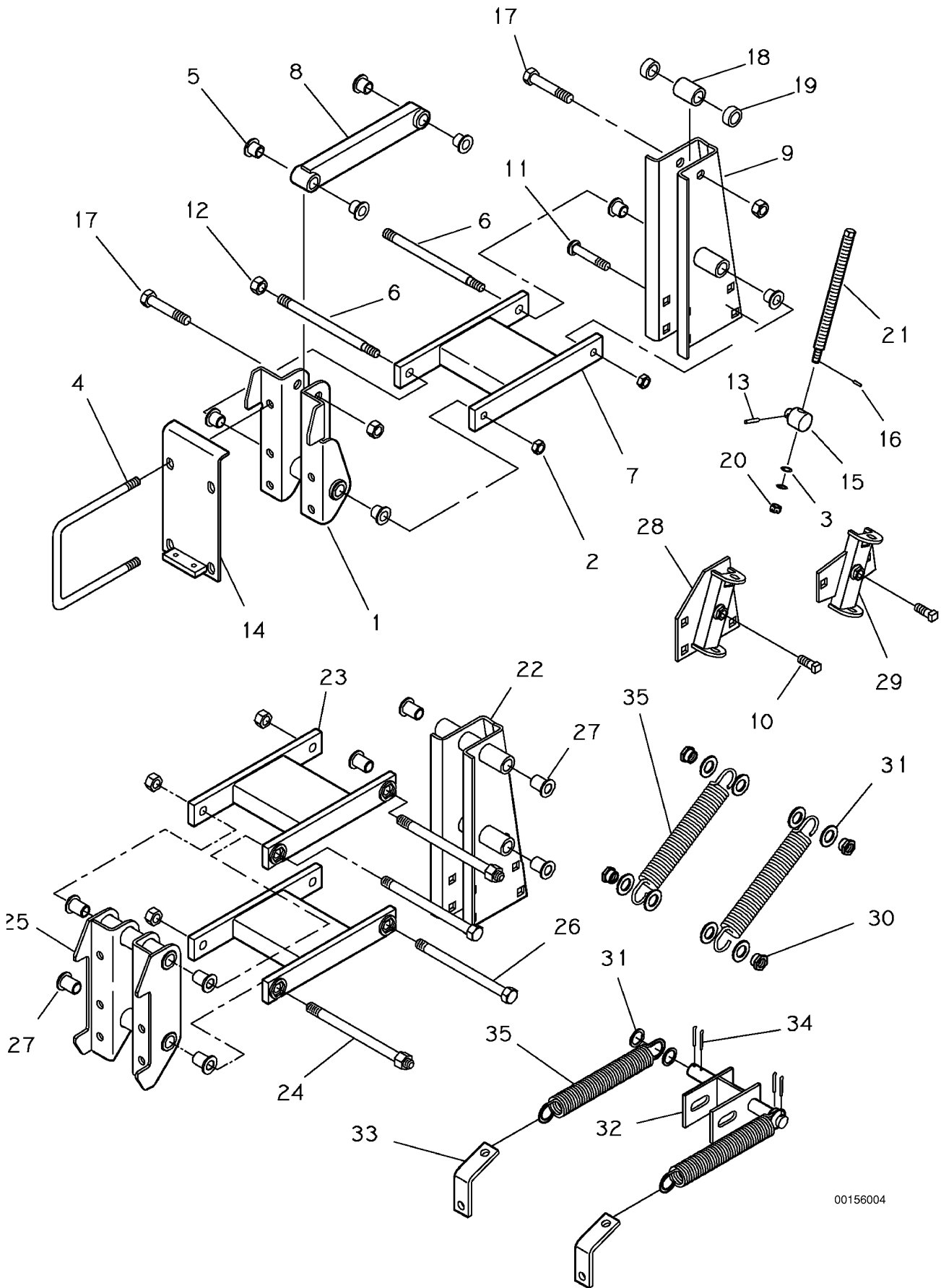

00156004

LINKAGE COMPONENTS

REF.	PART NO.	DESCRIPTION	QTY.
1	20021318	Mounting Angle without Oilite Bushings	1
2	90006145	5/8 NC Flanged Whiz Nut	2
3	90011146	Machine Bushings, .88 OD x .53 ID	2
4	20030344	5/8 U-bolt, 7" Inside, 8.5" Long	2
5	20030877	Oilite Bushing	8
6	20032631	Pivot Shaft	2
7	20021412	Parallel Arm	1
8	20021744	Parallel Tube	1
	20021779	Parallel Tube (Double "H" Kit)	1
9	20021707	Upright Weld without Oilite Bushings	1
10	90016093	5/8 NC x 1-1/2 Sq. Head Set Screw	1
11	90001792	5/8 NC x 3-1/2 Carriage Bolt	4
12	90006510	3/4 NC Lock Nut	4
13	90029176	1/4 x 1-1/4 Roll Pin	1
14	20021729	Clamp Weldment, Model 2065	1
15	20031319	Collar, Screw Kit	1
16	90029082	1/8 x 3/4 Roll Pin	2
17	90001419	3/4 NC x 4 Hex Bolt	2
	90001441	3/4 NC x 9-1/2 Hex Bolt (Double "H" Kit)	2
18	20033104	Spacer, 2" Long (Double "H" Kit)	2
19	20033103	Spacer (Double "H" Kit)	4
20	90006052	1/2" NF Slotted Hex Nut	2
21	20033190	Adjusting Screw	1
22	20021856	Upright Weld without Oilite Bushings (Double "H")	1
23	20021859	Parallel Arm (Double "H")	2
24	20021860	Pin (Double "H")	2
25	20021852	Mounting Angle without Oilite Bushings (Double "H")	1
26	20021861	Bolt (Double "H")	2
27	20033544	Oilite Bushing (Double "H")	8
28	20021864	Gauge Arm Pocket, 4 Bolt (2140 & 2130)	1
29	20021926	Gauge Arm Pocket, 2 Bolt (2065)	1
30	20033546	Retainer	4
31	90011073	1 x 10 Ga. Nar Rim Mach. Bushing	A/R
32	20021371	Spring Mount Bracket	1
	20021694	Spring Mount Bracket (Double "H" Linkage Kit)	1
33	20033264	Hook Weldment	2
34	90023043	3/16 x 1-1/2 Cotter Pin	4
35	20032163	Spring, (Double "H")	2
	20021738	Linkage Assembly (Ref. 1,2,5-12)	1
	20021857	Linkage Assembly, Double "H" (Ref. 22-27)	1

TINES, SHOVELS & SWEEPS

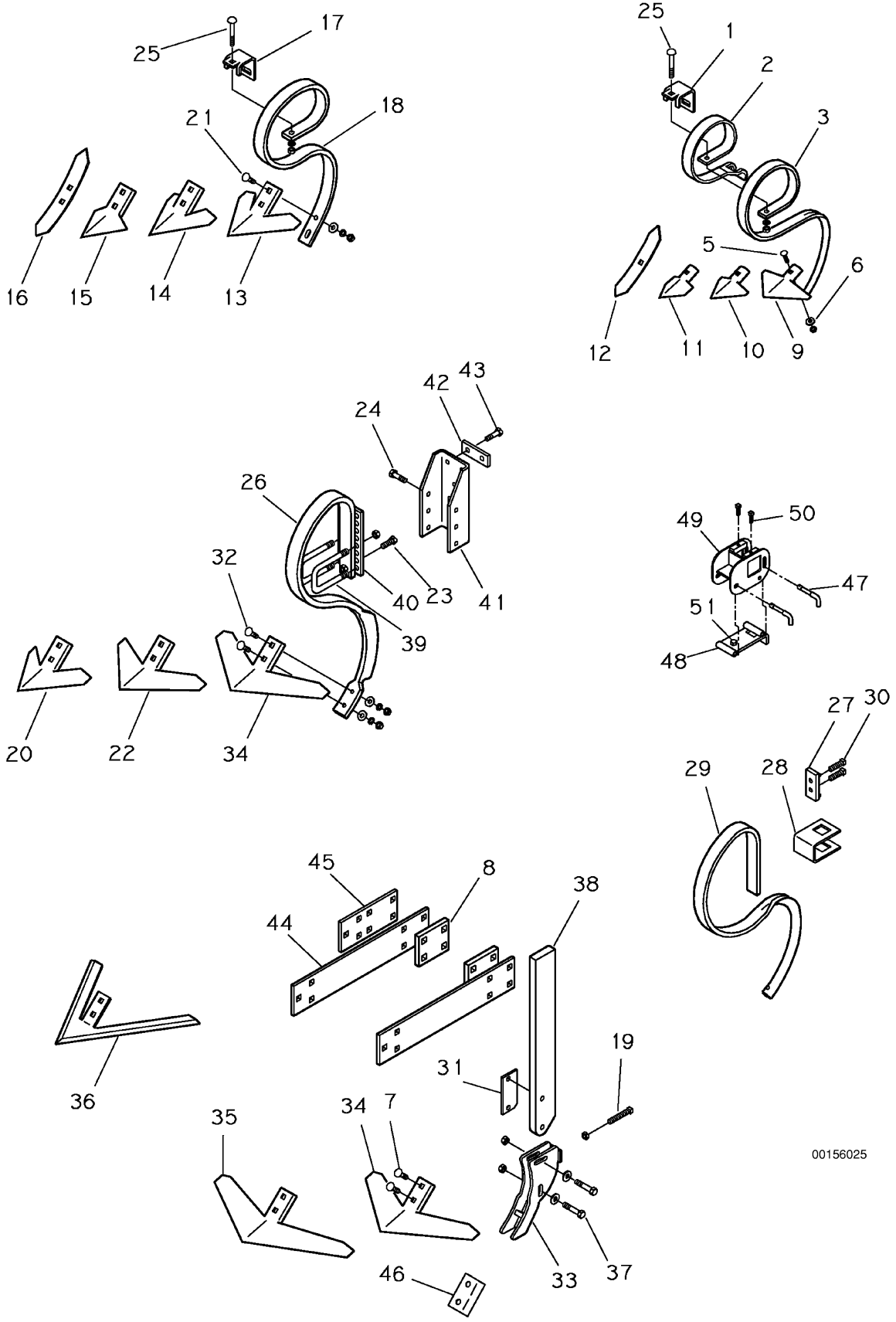

00156025

TINES, SHOVELS & SWEEPS

REF.	PART NO.	DESCRIPTION	QTY.
1	20031835	Spring Tine Clamp with Helper	1
	20031833	Spring Tine Clamp without Helper	1
2	20031754	Spring Tine Helper	1
3	20031755	Spring Tine	1
4	20031833	Spring Tine Clamp	1
5	90001841	3/8 NC x 1-1/2 Elliptical Head Plow Bolt	1
	20010648	Box of 100 Bolts and Nuts	1
6	90011229	Tine Washer	1
7	90001865	Plow Bolt, 1/2 NC x 3-1/2	2
8	20032539	Spacer Plate, 1 x 3 Shank (2065)	2
	20033127	Spacer Plate, 3/4 x 2-1/2 Shank	2
9	90510005	Regular Shovel, 7" x 1/4" (S-Tine)	1
10	90510004	Regular Shovel, 4" x 1/4" (S-Tine)	1
11	90510003	Regular Shovel, 2-3/4" x 1/4" (S-Tine)	1
12	90510088	Regular Spike, 1-1/2" Reversible (S-Tine)	1
13	90510072	Penetrator Shovel, 8" x 1/4" x 47 Degree	1
14	90510071	Penetrator Shovel, 6" x 1/4" x 47 Degree	1
15	90510019	Penetrator Shovel, 4" x 1/4" x 47 Degree	1
16	90510018	Penetrator Spike, 1-3/4" x 1/4"	1
17	20030539	Clamp, Penetrator Tine	1
18	20030470	Penetrator Tine	1
19	90016066	1/2 NC x 2 Sq. Head Set Screw	1
20	90510112	8" Penetrator Sweep, 43 deg (Straight Edge Tine)	1
	90510123	7" Penetrator Sweep (Ultra Wing)	1
21	90001851	7/16 x 1-3/4 Plow Bolt	1
22	90510113	12" Sweep, 43 deg (Straight Edge Tine)	1
23	90001225	1/2 NC x 1-1/2 Hex Bolt	1
24	90001223	1/2 NC x 1-1/4 Hex Bolt	4
25	90001734	7/16 NC x 3-1/2 Carriage Bolt	1
26	20033524	Tine, Heavy Duty 20" Adjustable (5/8")	1
	20033525	Tine, Heavy Duty 20" Adjustable (3/4")	1
27	20021391	Tine Clamp Weldment	1
28	20032594	Tine Clamp	1
29	20032379	Vertical Tine	1
30	90016065	1/2 NC x 1-3/4 Sq. Head Set Screw	1
31	20031066	Spacer	1
32	90001902	Plow Bolt, 1/2" Head, 7/16 x 2	1
33	20021642	Sweep Adapter Weldment, 2" Wide	1
	20021840	Sweep Adapter Weldment, 1-3/4" Wide	1
34	90510107	16" Sweep (43 Degree)	1
35	90510115	18" Sweep (43 Degree)	1
	90510108	20" Sweep (43 Degree)	1
	90510109	24" Sweep (43 Degree)	1
	90510116	26" Sweep (43 Degree)	1
	90510117	28" Sweep (43 Degree)	1
36	90510114	14" Beet Sweep	1
	90510126	14" Beet Sweep (Heavy Duty)	1
	90510120	20" Beet Sweep	1
37	90001233	1/2 NC x 2-1/2 Hex Bolt	1

TINES, SHOVELS & SWEEPS

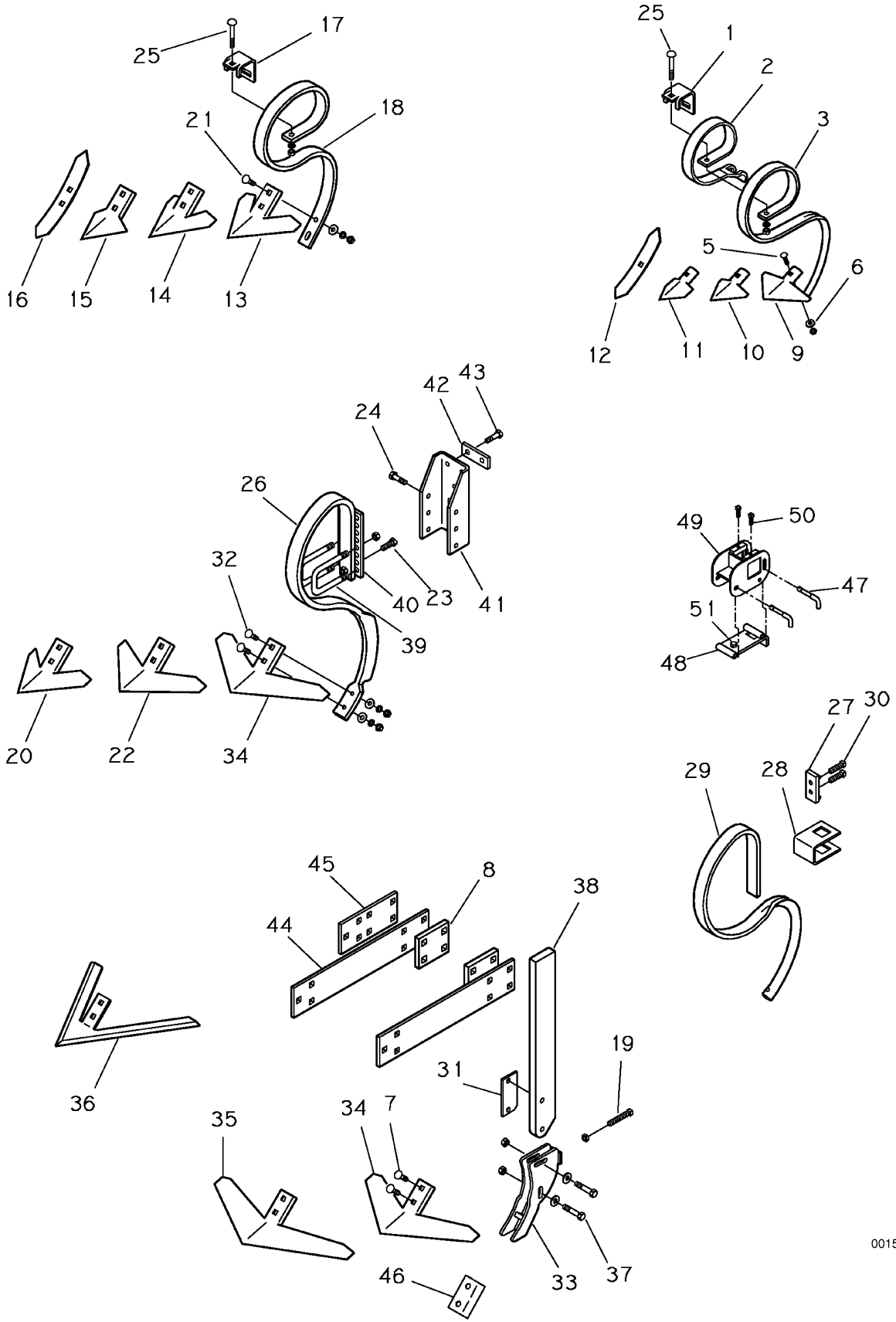

00156025

TINES, SHOVELS & SWEEPS

REF.	PART NO.	DESCRIPTION	QTY.
38	20031064	Shank, 3/4 x 23" Long	1
	20031063	Shank, 3/4 x 30" Long	1
	20031061	Shank, 1 x 24" Long	1
	20031062	Shank, 1 x 16" Long	1
	20031061	Shank, 1 x 23" Long	1
	20031060	Shank, 1 x 30" Long	1
	20032954	U-Bolt, 1/2 NC x 2 x 3-3/4	2
39	20032856	U-Bolt, 1/2 NC x 2-1/2 x 4-1/4	2
40	20032955	Plate, 2 x 2	1
	20032847	Plate, 2-1/2 x 2-1/2	1
41	20032938	Bracket, (2130)	1
42	20032944	Back Strap, (2130)	1
43	90001227	1/2 NC x 1-3/4 Hex Bolt	3
44	20033147	Side Plate, 1 x 3 Shank (Long)	2
	20033148	Side Plate, 3/4 x 2-1/2 Shank	2
45	20032538	Side Plate, 1 x 3 Shank (Short) (2065)	2
46	20033421	Spacer, Wide Sweeps	1
47	90025024	7/16 X 3 Hitch Pin	2
48	20021530	Tine Mount (Standard)	1
	20021589	Tine Mount (Penetrator)	1
49	20021531	Clamp Weldment	1
50	90016033	3/8 NC x 1 Square Head Set Screw	2
51	90001175	7/16 NC x 1-1/2 Hex Bolt (Standard)	1
	90001225	1/2 NC x 1-1/2 Hex Bolt (Penetrator)	1

SPRING TRIP SHANK (2065)

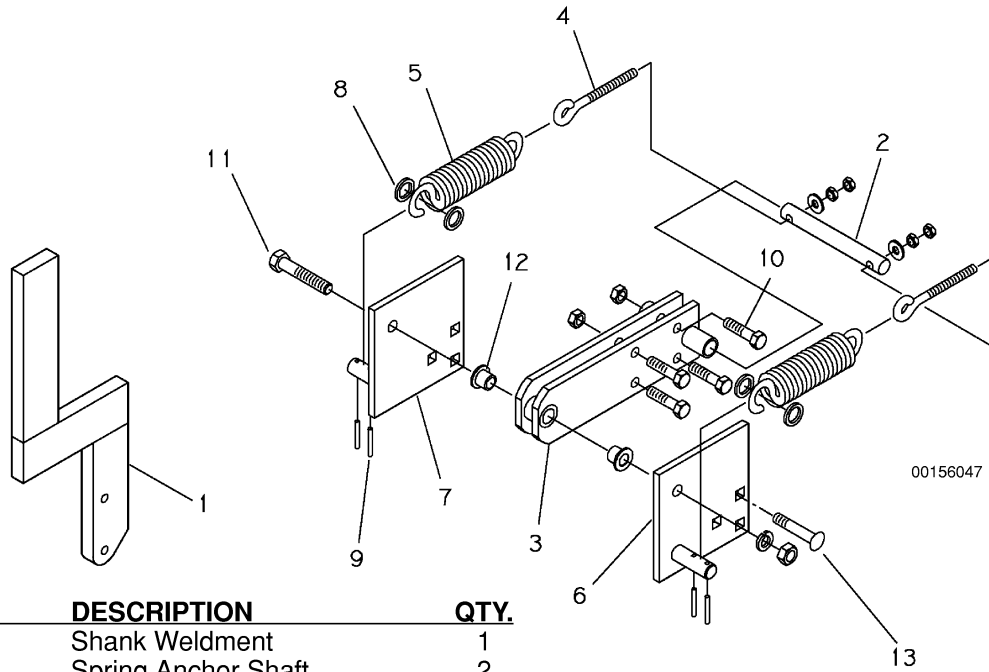

REF.	PART NO.	DESCRIPTION	QTY.
1	20021737	Shank Weldment	1
2	20033267	Spring Anchor Shaft	2
3	20021733	Pivot Weldment	1
4	10030148	1/2 Eye Bolt	2
5	20031745	Spring	2
6	20021734	Plate Weldment L.H.	1
7	20021735	Plate Weldment R.H.	1
8	90011073	1 x 10 Ga. Mach. Bushing	4
9	90029182	1/4 x 2 Roll Pin	4
10	90001349	5/8 NC x 2-1/2 Hex Bolt	4
11	90001419	3/4 NC x 4 Hex Bolt	1
12	20030877	Flanged Bushing	2
13	90001792	5/8 NC x 3-1/2 Carriage Bolt	3
	20021736	Trip Assembly	1

TINE TREES

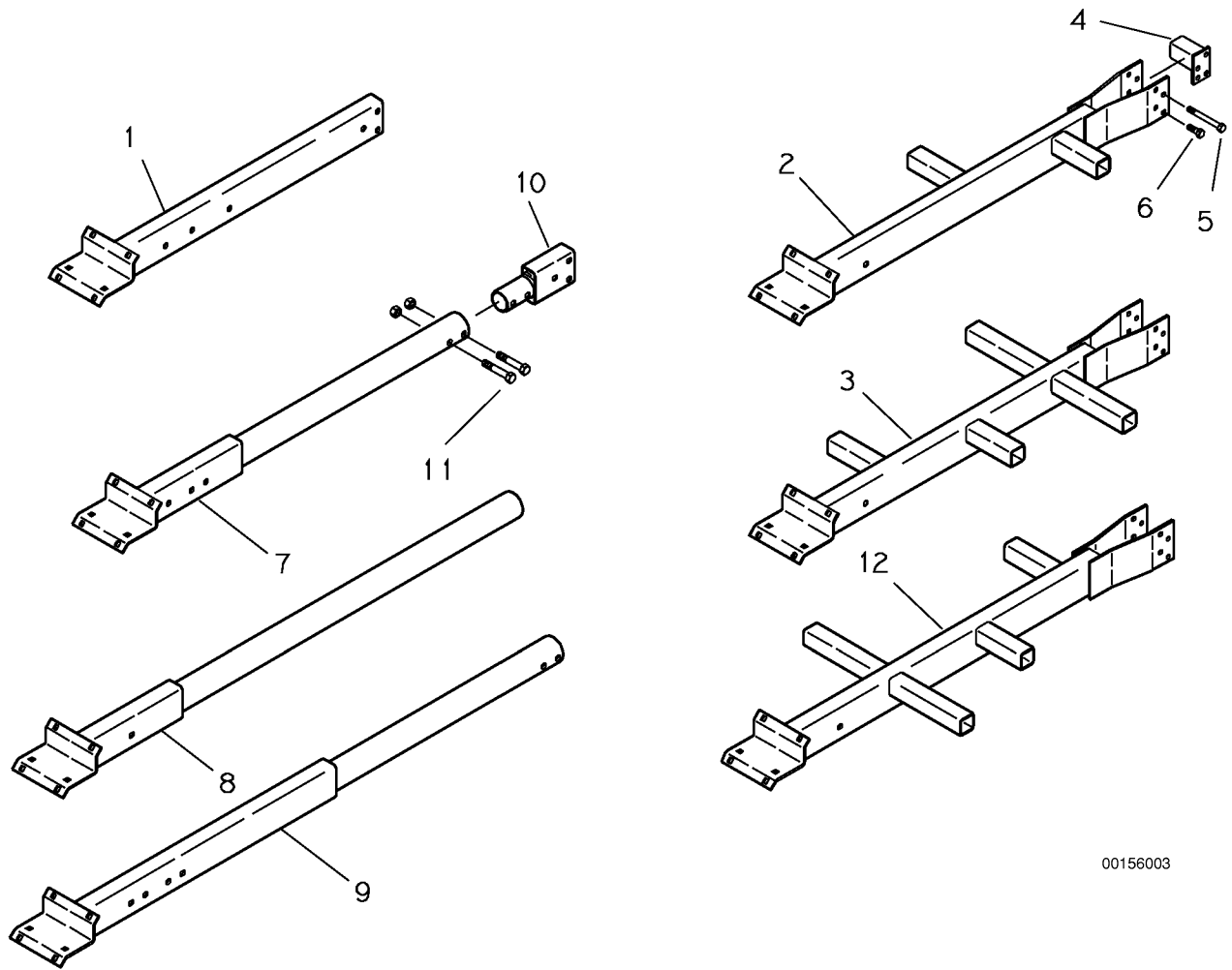

00156003

REF.	PART NO.	DESCRIPTION	QTY.
1	20020575	2 x 4 Adjustable Tree, (Model 2040 & 2065), 37.50" Long	1
	20021146	2 x 4 Adjustable Tree, (Model 3030), 27" Long	1
	20021845	2 x 4 Adjustable Tree, (Model 3030), 20" Long	1
2	20021480	2 x 4 Welded 3 Tine, Model 2130 (22" Rows), 39.50" long	1
	20021657	2 x 4 Welded 3 Tine, Model 2130 (22" Rows), Extended 44.31" long	1
3	20021524	2 x 4 Welded 5 Tine, Model 2130 (30" Rows), 48.50" Long	1
	20021650	2 x 4 Welded 5 Tine, Model 2130 (24"-24" Rows) 53.31" Long	1
4	20021639	Rear Tube Weldment, Model 2130	1
5	90001247	1/2 NC x 4-1/2 Hex Bolt	2
6	90001221	1/2 NC x 1 Hex Bolt	1
7	20021702	Tree Weldment (Spider Gang)	1
8	20021732	Tree Weldment (Spider Gang), Extended, without holes	1
9	20021825	Tree Weldment (Spider Gang)	1
10	20021708	Rear Tube Attachment	1
11	90001357	5/8 x 3-1/2 Hex Bolt	2
12	20021747	2 x 4 Welded 5 Tine, Model 2130	1
	20021845	2 x 4 Adjustable Tree, Model 3030, 20" long	1

GAUGE ARMS & WHEELS

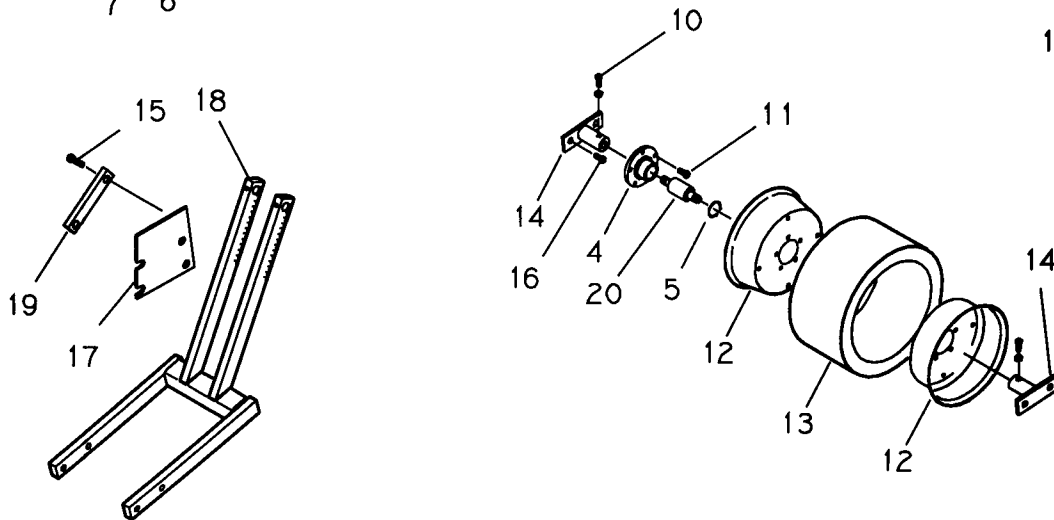
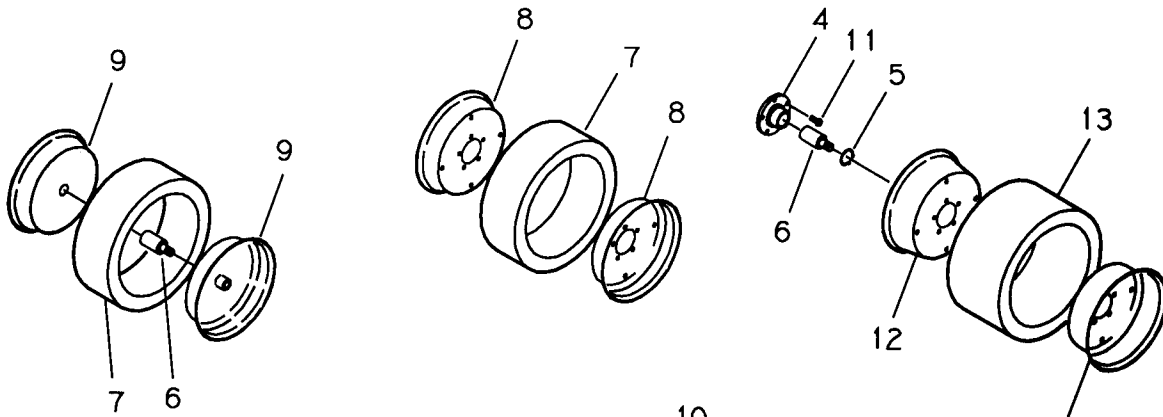
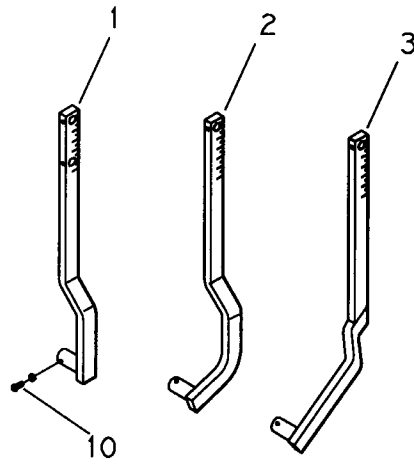

00156005

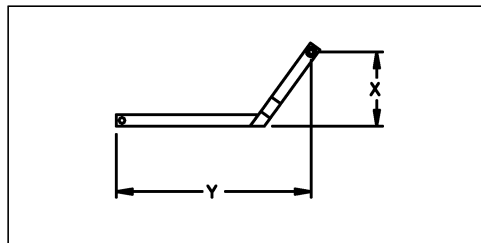

GAUGE ARMS & WHEELS

REF.	PART NO.	DESCRIPTION	QTY.
1	20021672	Gauge Arm, 6" Wide Tire (x=0, y=26) 2040 Shannon	1
2	20021674	Gauge Arm, 6" Wide Tire(x=4, y=26) 2040 Delta	1
3	20021673	Gauge Arm, 6" Wide Tire (x=9, y=26)	1
4	20030669	Hub	1
5	90039022	Retaining Ring	1
6	90101013	Gauge Wheel Bearing	1
7	90509105	Gauge Wheel Tire, 4 x 12	1
8	90509048	Rim Half, 4 x 12 (Hub Type)	2
9	90509017	Rim Half, 4 x 12	2
10	90016031	3/8 NC x 3/4 Sq. Head Set Screw	1
11	90001055	5/16 NC x 3/4 Hex Bolt	8
12	20033106	Rim Half, 6 x 12 Tire	2
13	20033107	Gauge Wheel Tire, 6 x 12	1
14	20021684	Wheel Holder, 2-9/16" long Bushing (6 x 12 Tire)	2
15	90001221	1/2 NC x 1 Hex Bolt	2
16	90001111	3/8 NC x 1-1/4 Hex Bolt	4
17	20021755	Gauge Pocket Weldment, Model 2065	1
18	20021756	Gauge Arm Weldment, Model 2065	1
19	20033311	Strap, Model 2065	1
20	90101264	Fork Type Bearing	1
	20021365	Gauge Wheel Tire Assembly (Ref. 7 and 8)	1
	90509016	Gauge Wheel Tire Assembly (Ref. 6, 7, and 9)	1
	20021669	Gauge Wheel Tire Assembly, 6" Wide (Ref 12 and 13)	1
	20021379	Hub Assembly (Ref. 4, 5, and 6)	1
	20021615	Fork Hub Assembly (Ref. 4, 5, and 20)	1
	20020475	Gauge Wheel Tire & Hub Assembly (Ref. 4-8)	1
	20021685	6" Gauge Wheel Tire & Fork Hub Assembly (Ref. 4,5,12,13, and 20)	1
	20021668	6" Gauge Wheel Tire & Hub Assembly (Ref. 4,5,6,12, and 13)	1

REAR TINE BRACKETS, BRANCHES & TUBES

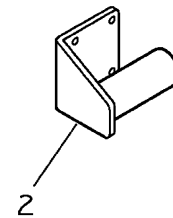
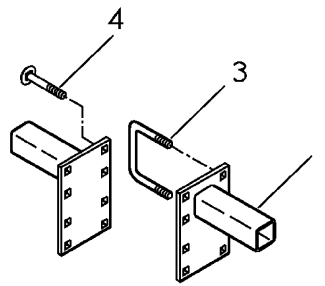
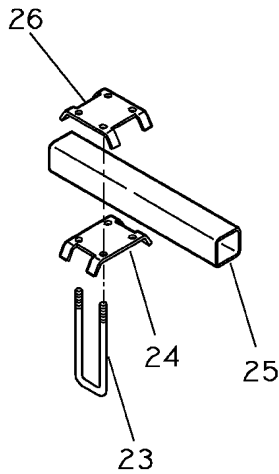
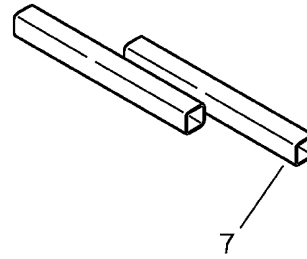
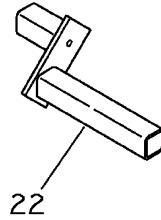
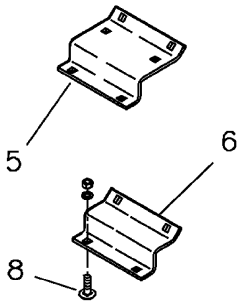
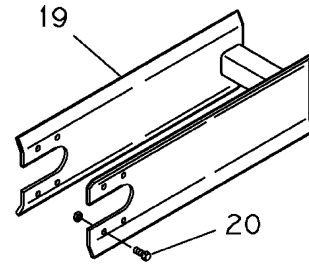
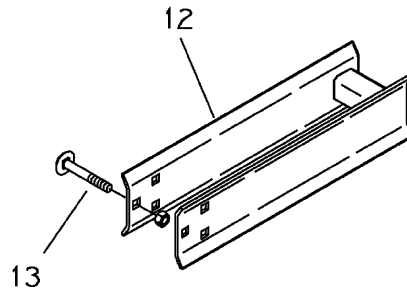
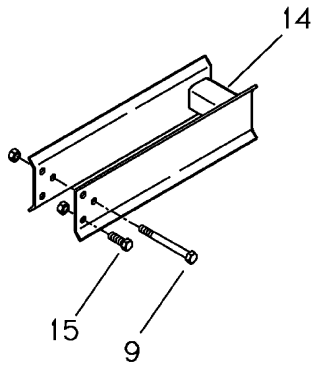
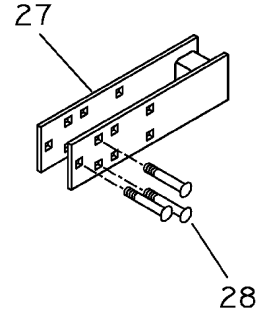
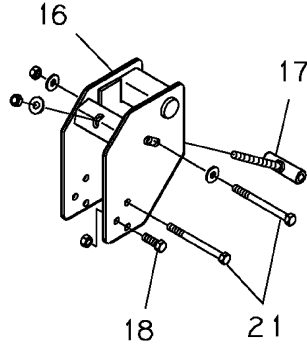
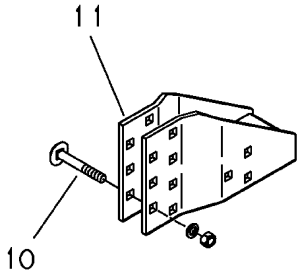

00156009

REAR TINE BRACKETS, BRANCHES & TUBES

REF.	PART NO.	DESCRIPTION	QTY.
1	20020574	Bolt on Branches, 8 Hole x 7"	1
	20020573	Bolt on Branches, 8 Hole x 10"	1
	20020672	Bolt on Branches, 8 Hole x 14"	1
	20020671	Bolt on Branches, 8 Hole x 17"	1
	20020673	Bolt on Branches, 8 Hole x 22"	1
2	20021449	Mount Weldment, Spider Gang	
3	20031445	U-Bolt, 1/2 NC x 4 x 2	4
4	90001759	1/2 NC x 3-1/2 Carriage bolt	4
5	20032533	Double Tube Clamp	1
6	20030994	Single Tube Clamp	1
7	20030019	Front Tube, 17-1/2"	1
	20030993	Front Tube, 20"	1
	20030992	Front Tube, 30"	1
	20030990	Front Tube, 38"	1
	20030988	Front Tube, 48"	1
8	90001726	7/16 NC x 1-1/2 Carriage Bolt	4
9	90002149	1/2 NC x 5 Hex Bolt, Model 2130	2
10	90001792	5/8 NC x 3-1/2 Carriage Bolt, Standard	3
11	20020668	Rear Tine Bracket, Adjustable	1
12	20021162	Rear Extension, Long 23-1/2" Long, Model 2040	1
	20021299	Rear Extension, Short 17" Long	1
13	90001784	5/8 NC x 1-1/2 Carriage Bolt, Standard	6
14	20021481	Rear Extension, Model 2130, 18" Long x 4" Wide	1
	20021806	Rear Extension, Model 2130 Pitch Bracket, 18" Long x 4-1/2" Wide	1
15	90001223	1/2 NC x 1-1/4 Hex Bolt, Model 2130	2
16	20021766	Pivot Weldment, Model 2130	1
17	20021768	Spacer Tube Weldment, Model 2130	1
18	90001221	1/2 NC x 1 Hex Bolt	6
19	20021763	Rear Setback, Model 3030	1
20	90001109	3/8 NC x 1 Hex Bolt	4
21	90001251	1/2 NC x 5-1/2 Hex Bolt	3
22	20021691	Front Tube Weldment, 2 x 2	2
	20021616	Front Tube Weldment, 2-1/2 x 2-1/2 (Prior 1994)	2
23	20032855	U-Bolt, 1/2 NC x 2 x 7.75" Long	4
24	20032853	Bracket, 2"	1
25	20032852	Tube, 2-1/2" Sq. x 17" Long	2
26	20032854	Bracket, 2-1/2"	1
27	20021550	Rear Extension (2065)	1
28	90001794	5/8 NC x 4 Carriage Bolt	3

DUAL DISC & DUAL KNIFE ASSEMBLY

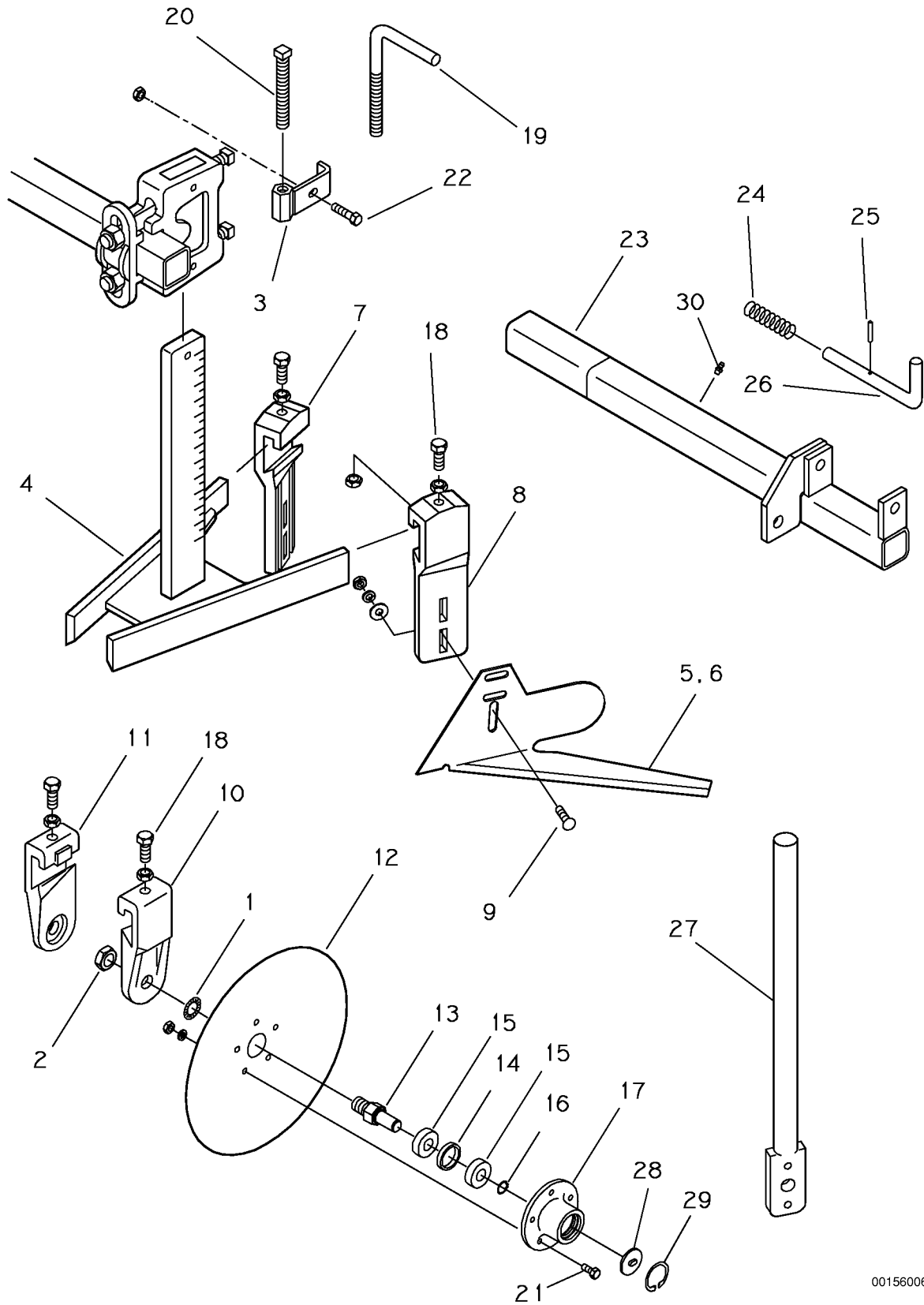

00156006

DUAL DISC & DUAL KNIFE ASSEMBLY

REF.	PART NO.	DESCRIPTION	QTY.
1	90011190	3/4 Internal Star Washer	1
2	90006282	3/4 NC Jam Nut	1
3	20021418	Adjustable Nut Weld, 3/4 x 2-1/2 Shank	1
	20021445	Adjustable Nut Weld, 5/8 x 2 Shank (Old)	1
4	20020690	Shank Weld, Heavy Duty, 3/4 x 2-1/2	1
	20021486	Shank Weldment (Model 2130) 3/4 x 2-1/2	1
	20020697	Shank Weldment (Old) 5/8 x 2	1
5	20031256	Weeder Knife, Left, Long	1
	20033684	Weeder Knife, Left, 8-3/16" Blade (3030)	1
	20031816	Weeder Knife, Left, (7-12" Blade)	1
6	20031255	Weeder Knife, Right, Long	1
	20033685	Weeder Knife, Right, 8-3/16" Blade (3030)	1
	20031817	Weeder Knife, Right, (7-12" Blade)	1
7	20031251	Weeder Knife Bracket, Right	1
8	20031253	Weeder Knife Bracket, Left	1
9	90001697	3/8 x 1-1/2 Carriage Bolt	2
10	20033156	Dual Disc Bracket, Left (18 Deg.) Standard	1
11	2003157	Dual Disc Bracket, Right (18 Deg.) Standard	1
	20033155	Dual Disc Bracket (12 Deg.) Left & Right, Optional	1
12	90510078	Disc, 12" STD	2
	90510110	Disc, 14"	2
13	20031261	Axle	1
14	20031264	Spacer	1
15	90101143	Bearing	2
16	90039029	Snap Ring, 5/8 ID, 3/4 OD x 1/32	1
17	20033279	Hub, Machined	1
18	90001225	1/2 NC X 1-1/2 Hex Bolt	1
19	20032767	Adjustment Rod (Shown)	1
20	90016319	Adjustment Rod, 2130 Only 5/8 x 4 Sq. Head Set Screw	1
21	90001055	5/16 NC x 3/4 Hex Bolt	1
22	90001113	3/8 NC x 1-1/2 Hex Bolt (Model 2130)	1
	90001115	3/8 NC x 1-3/4 Hex Bolt (Model 2060)	1
23	20021695	Disc Tube Weldment, 22"-24"	1
	20021696	Disc Tube Weldment, 26"-30"	1
	20021697	Disc Tube Weldment, 36"-40"	1
24	20032735	Spring	1
25	90029132	3/16 x 1-1/4 Roll Pin	1
26	20031945	Pin	1
27	20031945	Shank, 1-1/4 (for Disc or Knife)	1
28	20033278	Plastic Dust Cap	1
29	90039048	Snap Ring	1
30	90515013	Zerk, 3/16 Drive In	1
	20020694	Axle & Bearing Assembly (Ref. 13,14,15,16)	1
	20020695	Hub Assembly (Ref. 13-17)	1
	20020696	12" Disc & Hub Assembly	1
	20021636	14" Disc & Hub Assembly	1
	20020926	12" Disc Assembly & Adapters, Right 18 Deg. (Ref. 11-18,21,24,25,)	1
	20020925	12" Disc Assembly & Adapters, Left 18 Deg. (Ref. 10,12-18,21,24,25)	1
	20021637	14" Disc Assembly & Adapters, 12 Deg. (Ref. 11-18,21,24,25)	1
	20021698	Disc Mount Tube Assembly, 22"-24" (Ref 23-26)	1
	20021699	Disc Mount Tube Assembly, 26"-30" (Ref 23-26)	1
	20021700	Disc Mount Tube Assembly, 36"-40" (Ref 23-26)	1
	20021775	Hub Assy. (Ref 17, 28, 29)	1

MODEL 3030 COMPONENTS

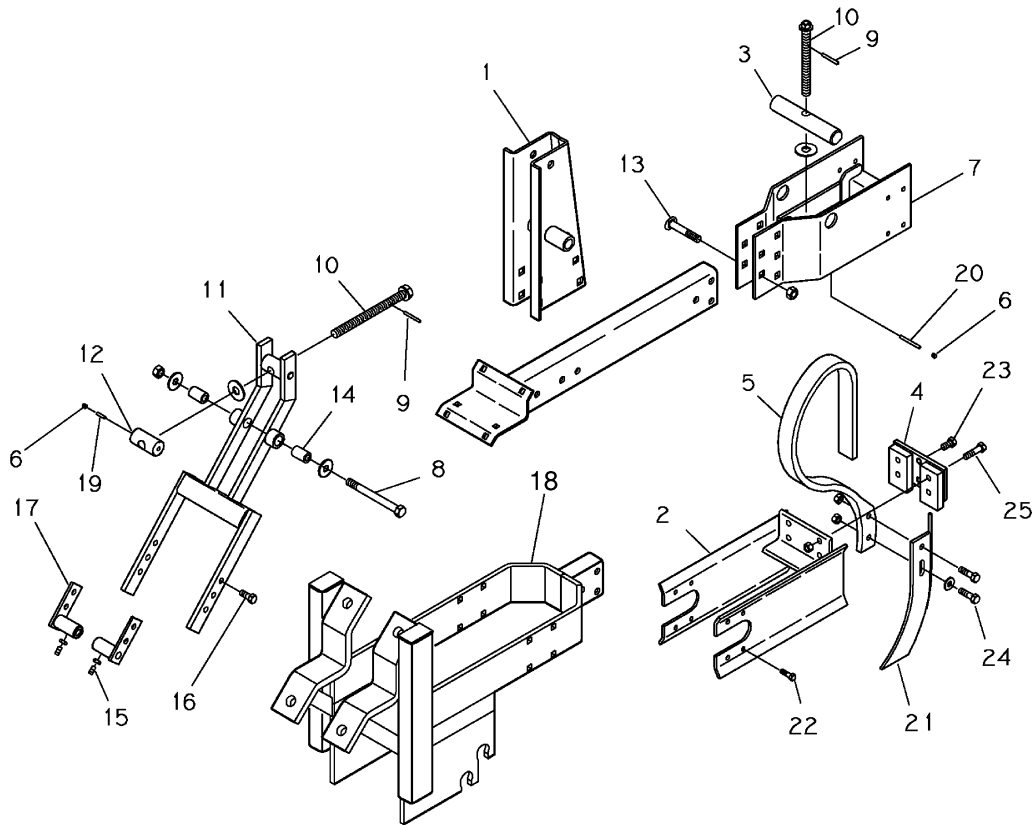

00156028

REF.	PART NO.	DESCRIPTION	QTY.
1	20021707	Upright Weldment	1
2	20021848	Setback Weldment	1
3	20033523	Trunion, Tine Adjustment	1
4	20021849	Guide Block Weldment	1
5	20033512	Tine, Heavy Duty NH3	1
6	90016237	5/16 x 5/16 Socket Set Screw	2
7	20021850	Pivot Assembly	1
8	90001371	5/8 NC x 6-1/2 Hex Bolt	1
9	90029182	1/4 x 2 Roll Pin	1
10	20033219	Screw, Gauge Arm	1
11	20021704	Gauge Arm Weldment	1
12	20033201	Trunion, Threaded	1
13	90001792	5/8 NC x 3-1/2 Carriage Bolt	6
14	20033200	Bushing, Pivot	2
15	90016031	3/8 NC x 3/4 Square Head Set Screw	2
16	90001223	1/2 NC x 1-1/4 Hex Bolt	4
17	20021705	Wheel Holder	2
18	20021925	Strut Weldment, (20" Tree)	1
	20021738	Linkage Assembly (all parts not shown on this page).	1
19	20033437	1/4" RND, 1", UHMW	1
20	20033438	1/4" RND, 2-1/2", UHMW	1
21	20033517	Anhydrous Knife	1
22	90001109	3/8 NC x 1 Hex Bolt	4
23	90001221	1/2 NC x 1 Hex Bolt	2
24	90001227	1/2 NC x 1-3/4 hex Bolt	2
25	90001229	1/2 NC x 2 Hex Bolt	4

TOOL BAR CLAMPS

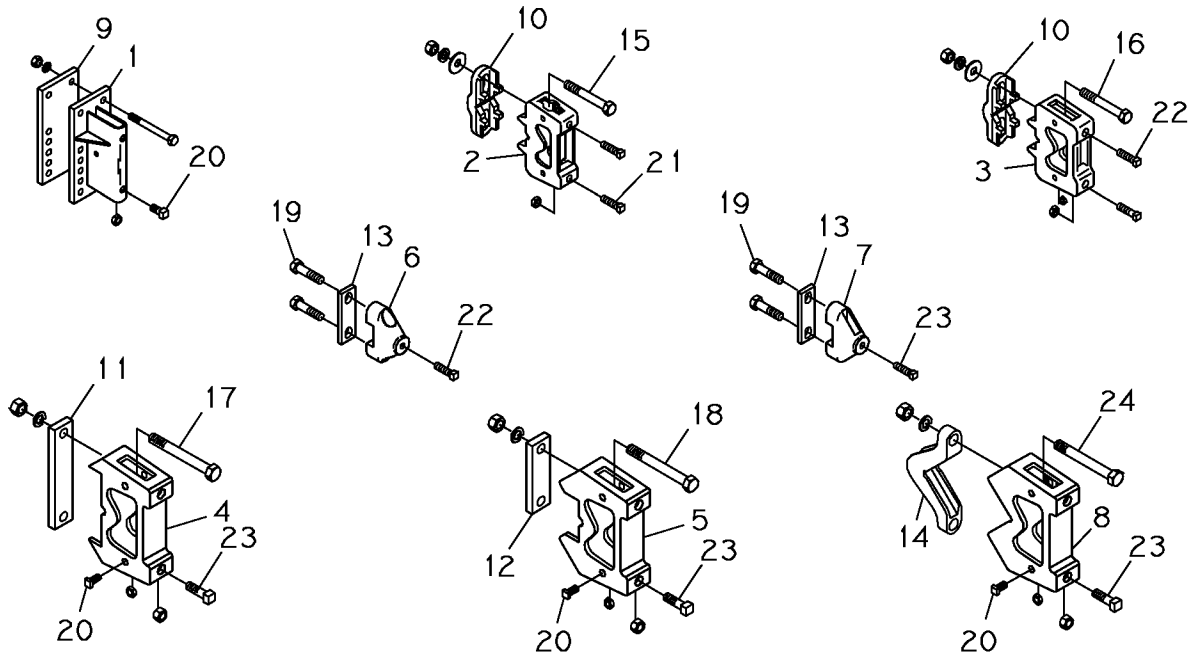

00156037

REF.	PART NO.	DESCRIPTION	QTY.
1	20020583*	Clamp Body	1
	20020582	Clamp Assembly, 3"-7" Square or Rectangular	1
2	20031015*	Clamp Body	1
	20020581	Clamp Assembly, 2" Square or Rectangular, Diamond thru 2"	1
3	20032242*	Clamp Body, Medium	1
	20021414	Clamp Assembly, 2" Square or Rectangular, Diamond thru 2"	1
4	20031022*	Clamp Body	1
	20020586	Clamp Assembly	1
5	20031025*	Clamp Body	1
	20020587	Clamp Assembly	1
6	20032776*	Clamp Body	1
	20021455	Clamp Assembly	1
7	20032689*	Clamp Body	1
	20021457	Clamp Assembly	1
8	20032241*	Clamp Body	1
	50020143	Clamp Assembly	1
9	20032357*	Back Plate	1
10	20031759*	Clamp Back Bracket	1
11	20031024*	Back Strap, 7"	1
12	20031026*	Back Strap, 4"	1
13	20032686*	Back Strap	1
14	50030523*	Clamp Back, Diamond	1
15	90001363	5/8 NC x 4-1/2 Hex Bolt	2
16	90001421	3/4 NC x 4-1/2 Hex Bolt	2
17	90001441	3/4 NC x 9-1/2 Hex Bolt	2
18	90001429	3/4 NC x 6-1/2 Hex Bolt	2
19	90001349	5/8 NC x 2-1/2 Hex Bolt	2
20	90016063	1/2 NC x 1-1/4 Sq. Head Set Screw	2
21	90016065	1/2 NC x 1-3/4 Sq. Head Set Screw	2
22	90016093	5/8 NC x 1-1/2 Sq. Head Set Screw	2
23	90016095	5/8 NC x 2 Sq. Head Set Screw	2
24	90001425	3/4 NC x 5-1/2 Hex Bolt	2

* Parts Available in assemblies only

KING GUIDE STRUT ASSEMBLY

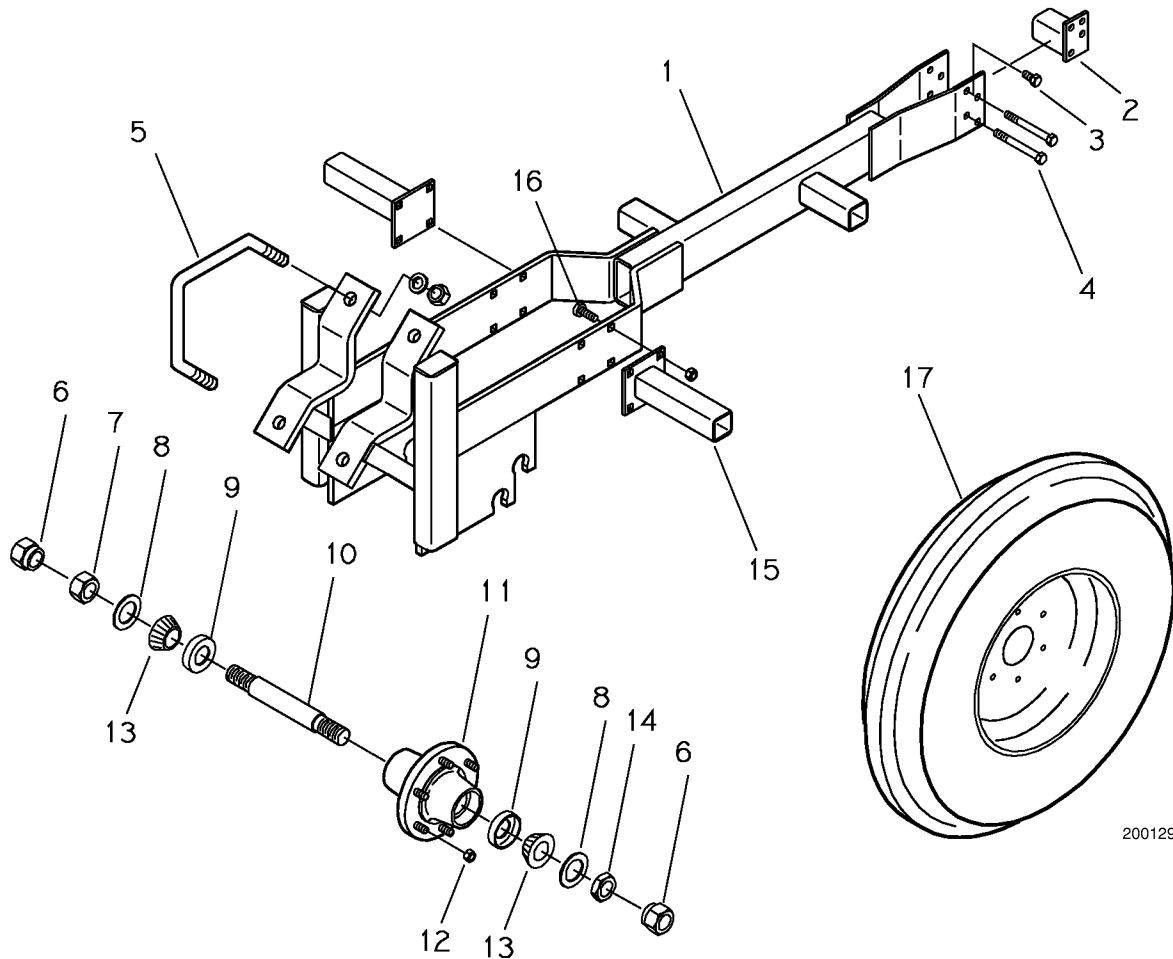

20012970

REF.	PART NO.	DESCRIPTION	QTY.
1	20021392	Strut Weldment	1
2	20021639	Rear Tube Weldment	1
3	90001221	1/2 NC x 1 Hex Bolt	1
4	90001247	1/2 NC x 4-1/2 Hex Bolt	2
5	20031443	ABolt, 7/8 NC x 7 x 7	2
6	20031847	1-1/4 NF Shoulder Nut	2
7	20032726	1-1/4 NF Nut, Short	2
8	90109127	Seal	2
9	90101148	Bearing Cup	2
10	20031240	Spindle	1
11	90509082	Hub with Cups	1
12	90509011	Wheel Nuts, 1/2 NF	6
13	90101149	Bearing Cone	2
14	90006024	1-1/4 NF Hex Nut	1
15	20021435	Tube Weldment	1
16	90001751	1/2 NC x 1-1/2 Carriage Bolt	8
17	20020988	Rim and Tire Assembly (Ref. 14,15)	1
	90509014	Rim, 16 x 6 LB, 6 Bolt	1
	90509019	Tire, 5.50 x 16 Single Rib	1
	20020928	Hub and Spindle Assembly (Ref. 6-13)	1

VEGETABLE GANG COMPONENTS

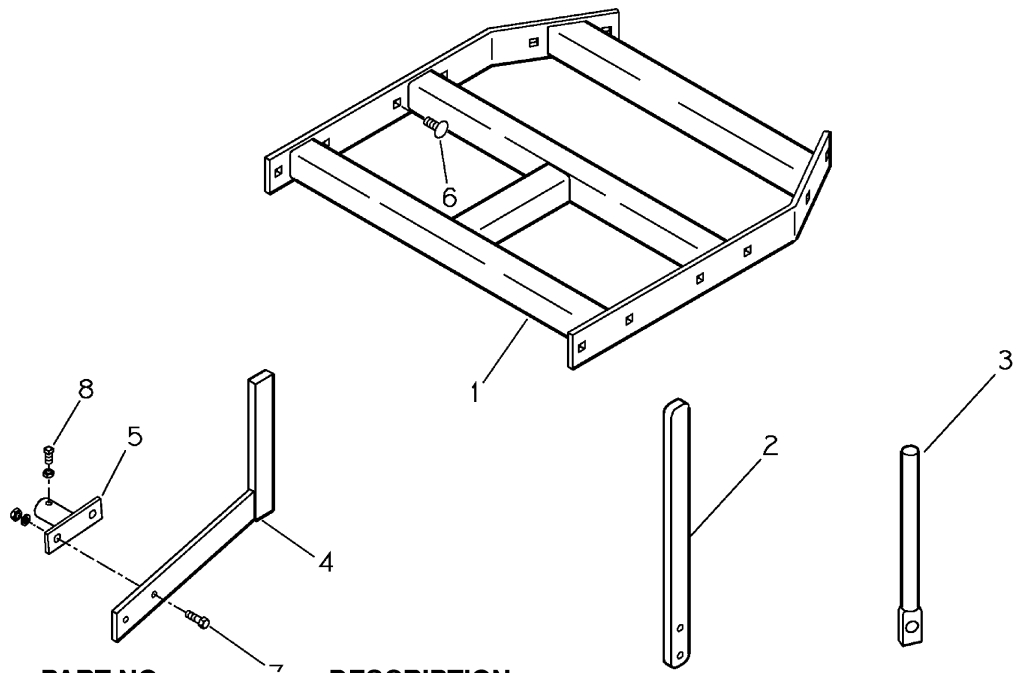

REF.	PART NO.	DESCRIPTION	QTY.
1	20021420	Tree Weldment	1
2	20032651	Knife Shank, 5/8 x 1-1/2	2
3	20032654	Disc Shank, 1" Round	2
4	20021653	Gauge Arm Weldment, Rectangular	2
	20021421	Gauge Arm Weldment, 1" Round	2
5	20021422	Gauge Wheel Holder	2
6	90001750	1/2 NC x 1-1/4 Carriage Bolt	2
7	90001111	3/8 NC x 1-1/4 Hex Bolt	4
8	90016031	3/8 NC x 3/4 Square Head Set Screw	2

NOTES

ADJUSTABLE GUIDE WHEELS

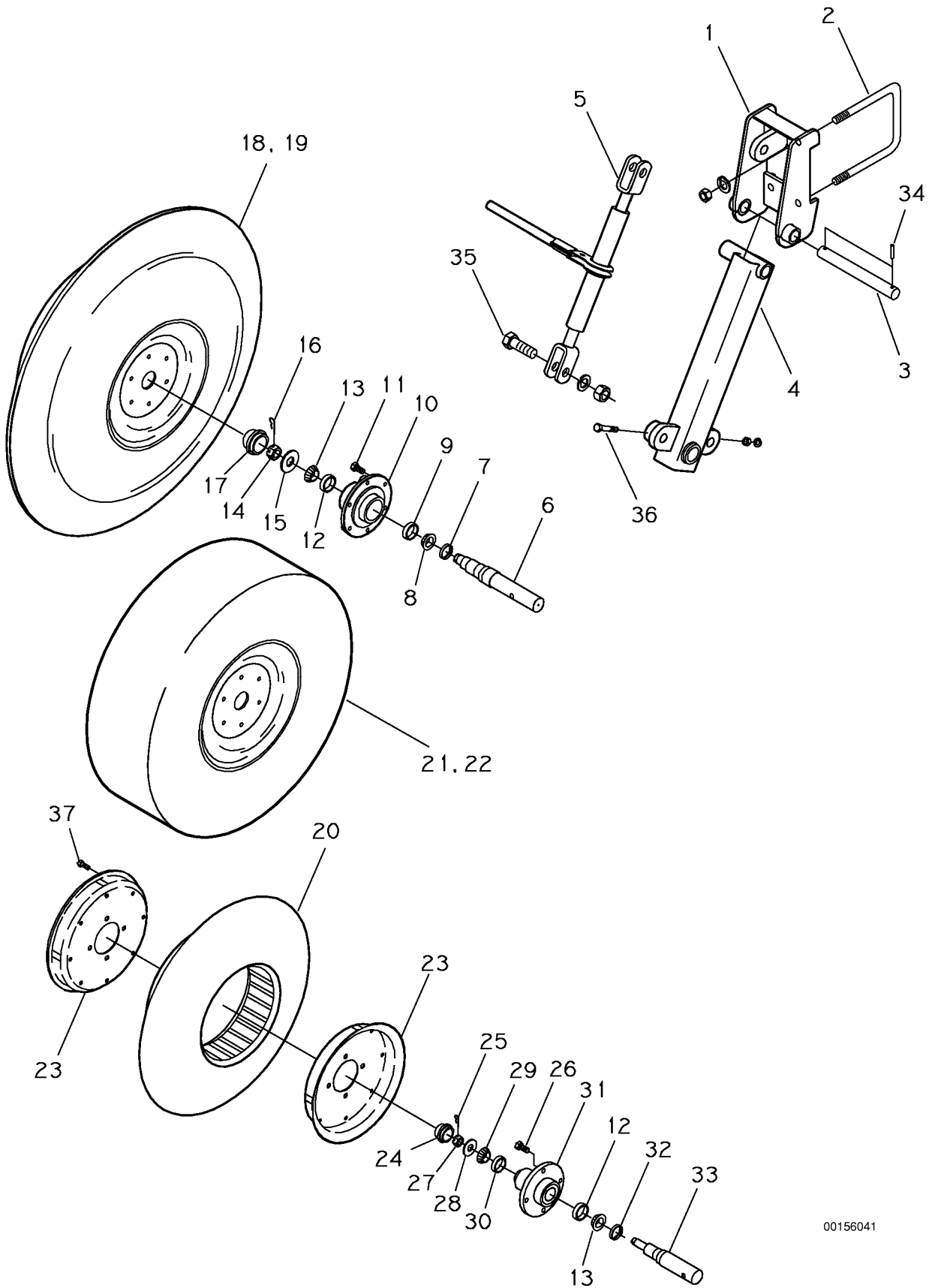

00156041

ADJUSTABLE GUIDE WHEELS

REF.	PART NO.	DESCRIPTION	QTY.
1	20020535	Mounting Bracket, 7 x 7	1
2	20030345	3/4 UBolt, 7" Inside, 9.125 Long	2
3	20030896	Pin, 1-1/4 x 10-7/8"	1
4	20020534	Adjustable Strut	1
5	90523009	Screw Jack	1
6	20031784	Spindle	1
7	90109002	Seal for 1.750 Spindle Seal Area	1
	90109209	Seal for 1.700 Spindle Seal Area	1
8	90101025	Bearing Cone, Inner	1
9	90101024	Bearing Cup, Inner	1
10	90509004	6 Bolt Hub	1
11	90509010	Wheel Bolt, 1/2 NF x 1-1/16	6
12	90101016	Bearing Cup, Outer	1
13	90101015	Bearing Cone, Outer	1
14	90006062	1" NF Slotted Hex Nut	1
15	90509068	1" Washer	1
16	90023045	Cotter Pin, 3/16 x 2	1
17	90509009	Dust Cap	1
18	90509019	Tire, 5.50 x 16 Single Rib Imp.	1
19	90509014	Rim, 16 x 6 LB, 6 Bolt	1
20	90509054	VTire, 4.50 x 20	1
21	90509077	Rim, 15" x 6" x 6 Hole	1
22	90509070	Tire, 9.5L x 15"8 Ply	1
23	20030891	Half Rim, 4 x 20	2
24	90509008	Dust Cap	1
25	90023043	Cotter Pin, 3/16 x 1-1/2	1
26	90001222	Hex Bolt, 1/2 NF x 1	4
27	90006058	3/4" NF Slotted Hex Nut	1
28	90509066	Washer, 3/4"	1
29	90101026	Bearing Cone, Outer	1
30	90101027	Bearing Cup, Outer	1
31	90509002	Hub, 4 Bolt	1
32	90109001	Seal for 1.500 Spindle Seal Area	1
	90109208	Seal for 1.460 Spindle Seal Area	1
33	20030892	Spindle	1
34	90029204	Roll Pin, 5/16 x 1-5/8	2
35	90001519	1" NC x 3 Hex Bolt	2
36	90001237	1/2" NC x 3 Hex Bolt	1
37	90001109	3/8 NC x 1 Hex Bolt	8
	20020931	6 Bolt Hub Assembly (Ref. 7-13 and 17)	1
	20020531	6 Bolt Hub & Spindle Assembly (Ref. 6-17)	1
	20020930	4 Bolt Hub Assembly (Ref. 12,13,24,29-32)	1
	20020530	4 Bolt Hub & Spindle Assembly (Ref. 12,13,24,29-33)	1
	20020988	Wheel Assembly (Ref. 18, 19)	1
	20020536	Wheel Assembly (Ref. 20, 23)	1

SEMI-PNEUMATIC GUIDE WHEEL & STEEL GUIDE WHEEL

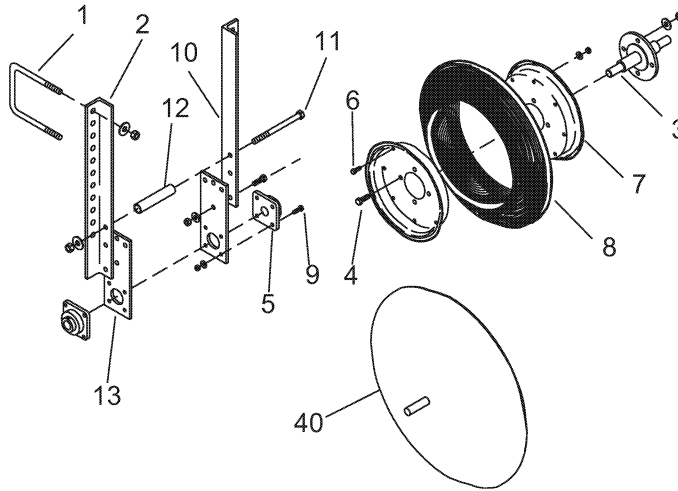

REF.	PART NO.	DESCRIPTION	QTY.
1	20030344	5/8 Ubolt, 7" Inside, 8-1/2 " Long	2
2	20032760	Angle, Right	1
3	20021315	Hub	1
4	90001225	1/2 NC x 1-1/2 Hex Bolt	8
5	90101004	1" 4Bolt Bearing, 2-3/4 Bolt Spacing	2
6	90001109	3/8 NC x 1 Hex Bolt	8
7	20030891	Half Rim, 4 x 20	2
8	90509054	VTire, 4.5 x 20	1
9	90001113	3/8 NC x 1-1/2 Hex Bolt	8
10	20032759	Angle, Left	1
11	90001377	5/8 NC x 8 Hex Bolt	1
12	20032758	Spacer Tube	1
13	20032815	Bearing Plate, 2-3/4 Bolt Spacing	2
14	20021496	Hub weldment	1
	20020536	Wheel & Tire Assembly (Ref. 6, 7 and 8)	1
	20022094	Steel Guide Wheel Weld	1

CURVED ARM SUPPORT WHEEL

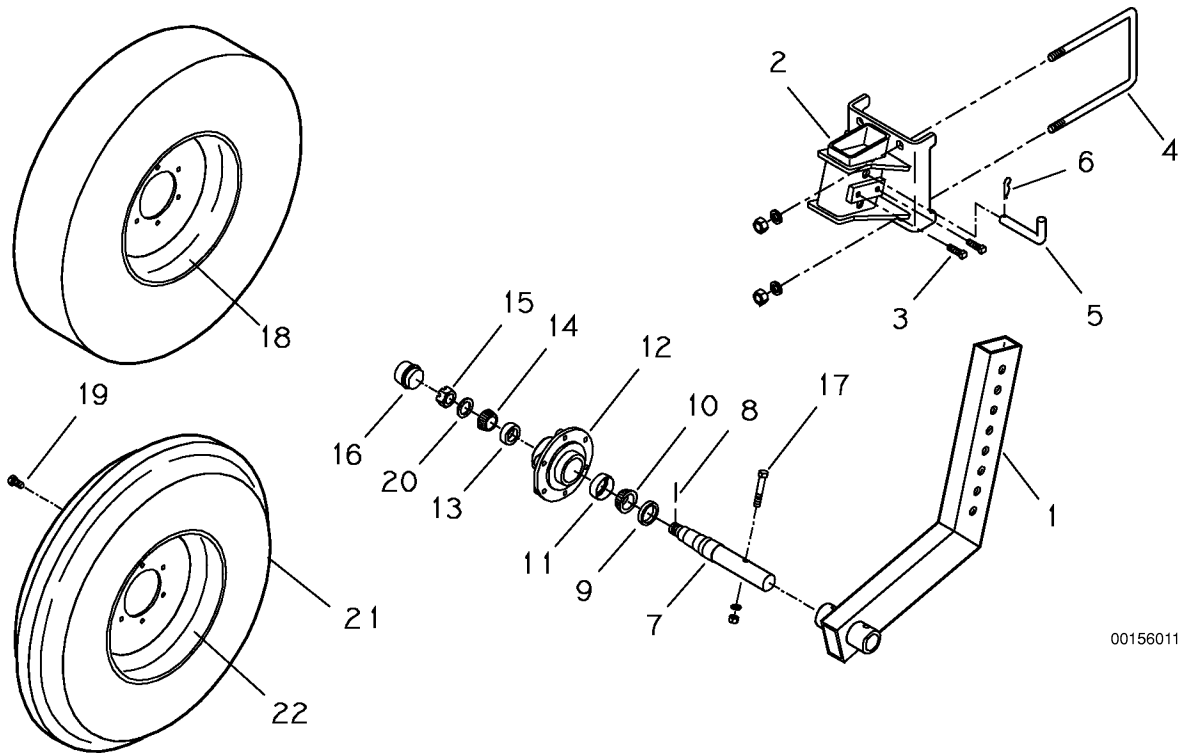

00156011

REF.	PART NO.	DESCRIPTION	QTY.
1	20021407	Curved Arm	1
2	20020434	Mounting Bracket, 8" Wide	1
3	90016064	1/2 NC x 1-1/2 Sq. Head Set Screw	2
4	20030609	3/4 UBolt, 7 x 7	2
5	20030606	Pin	1
6	90025005	5/32 Hair Pin Clip	1
7	20031784	Spindle	1
8	90023045	3/16 x 2 Cotter Pin	1
9	90109002	Seal for 1.750 Spindle Seal Area	1
	90109209	Seal for 1.700 Spindle Seal Area	1
10	90101025	Bearing Cone	1
11	90101024	Bearing Cup	1
12	90509004	6 Bolt Hub (with Cups)	1
13	90101016	Bearing Cup	1
14	90101015	Bearing Cone	1
15	90006062	1" NF Slotted Hex Nut	1
16	90509009	Dust Cap	1
17	90001237	1/2 NC x 3 Hex Bolt	1
18	90509077	Rim, 15" x 6 x 6 Hole	1
19	90509010	Wheel Bolt, 1/2 NF x 1-1/16	6
20	90509068	Washer	1
21	90509019	Tire, 5.50 x 16 Single Rib	1
22	90509014	Rim, 16 x 6 LB, 6 Bolt	1
	20020531	Hub & Spindle Assembly (Ref. 7-16 and 20)	1
	20020931	Hub Assembly (Ref. 9,10,11,12,13,14, and 15)	1
	20020988	Tire & Rim Assembly (Ref. 21 & 22)	1

YOKE ARM SUPPORT WHEEL

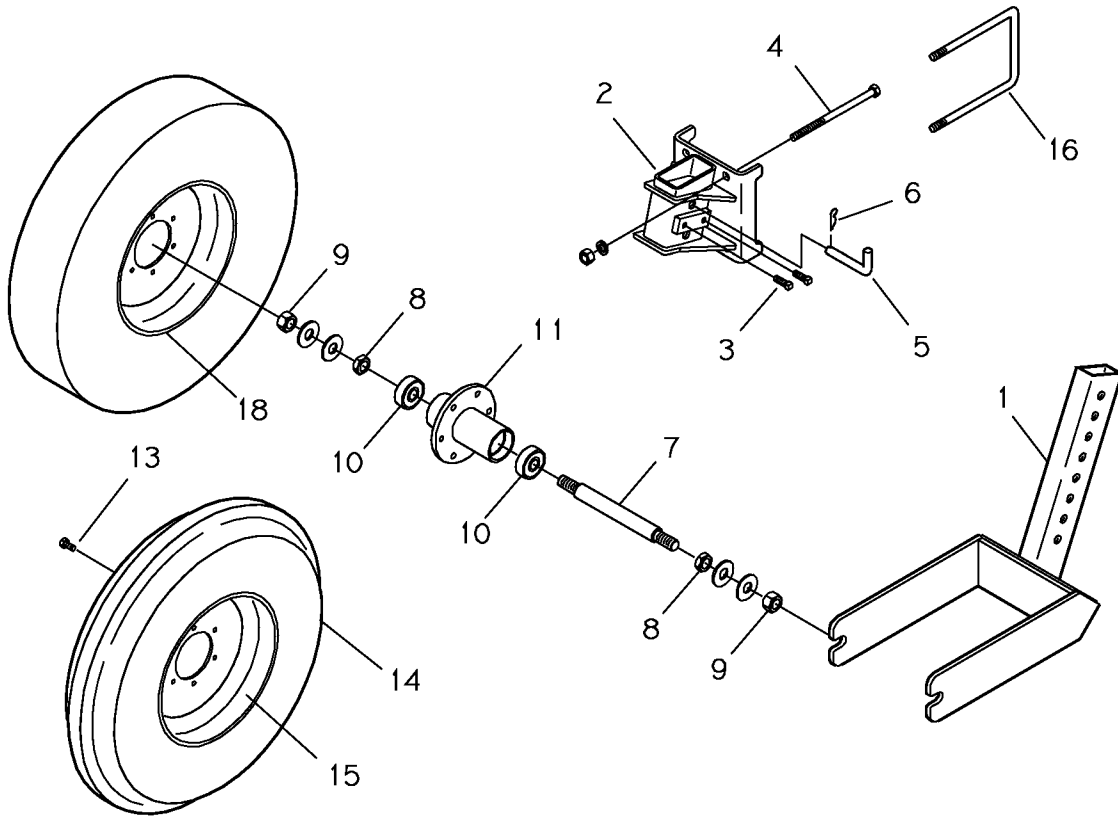

20013479

REF.	PART NO.	DESCRIPTION	QTY.
1	20021801	Arm, Yoke	1
2	20020434	Mounting Bracket, 8" Wide	1
3	90016064	1/2 NC x 1-1/2 Sq. Head Set Screw	2
4	90001385	5/8 NC x 10 Hex Bolt	4
5	20030606	Pin	1
6	90025005	5/32 Hair Pin Clip	1
7	20030604	Spindle	1
8	90006287	1" NC Jam Nut	2
9	90006020	1" NC Hex Nut	2
10	90101116	Bearing	1
11	20021803	Yoke Hub	1
12	90509077	Rim, 15" x 6 x 6 Hole	1
13	90509010	Wheel Bolt, 1/2 NF x 1-1/16	6
14	90509019	Tire, 5.50 x 16 Single Rib	1
15	90509014	Rim, 16 x 6 LB, 6 Bolt	1
16	20030609	3/4 UBolt, 7 x 7	2
	20021804	Yoke Hub Assembly (Ref 7,10,11 and 13)	1

STABILIZER COULTER

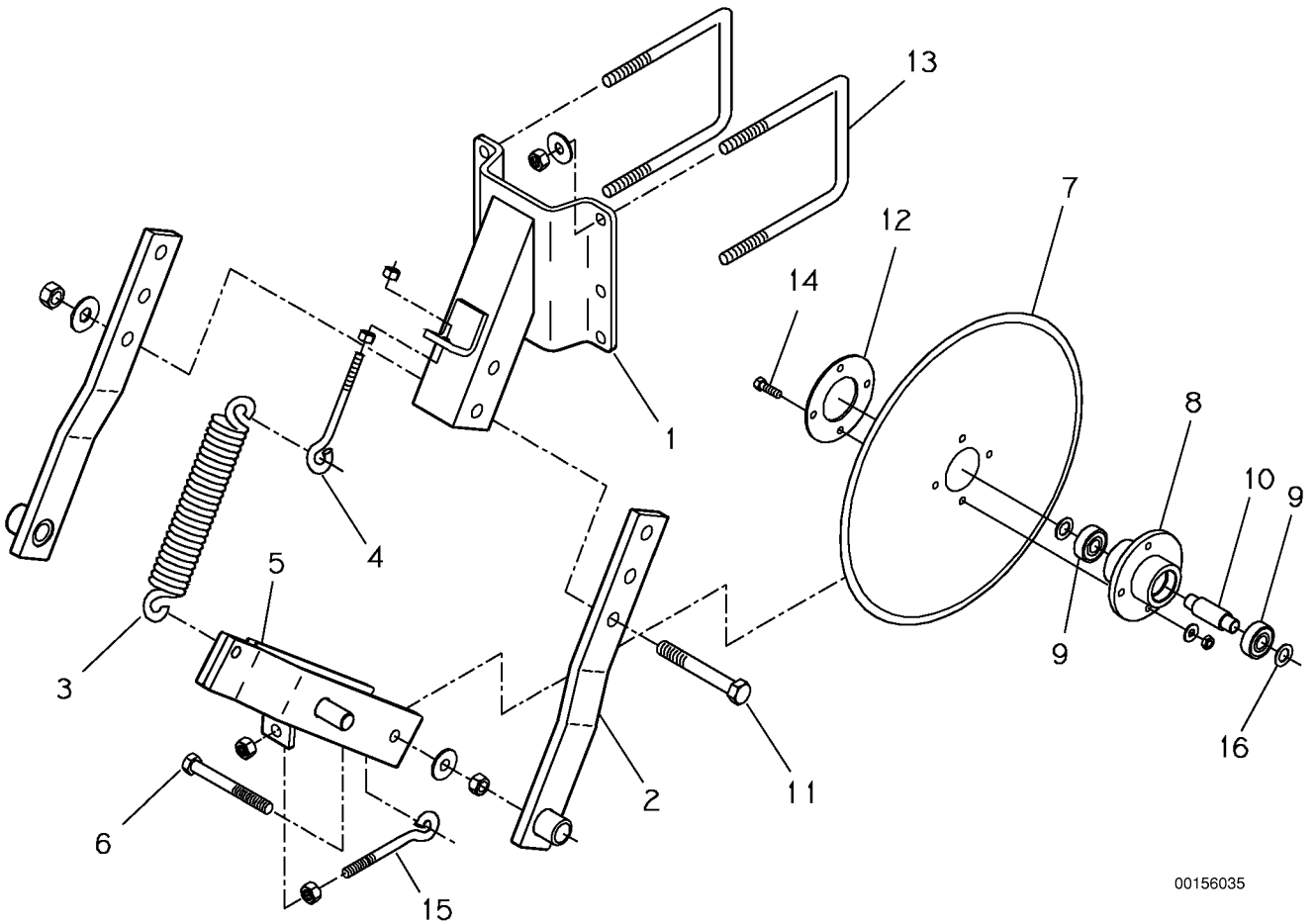

00156035

REF.	PART NO.	DESCRIPTION	QTY.
1	20020424	Frame Weldment	1
2	20020425	Side Arms	2
3	20033010	Spring, Painted	1
4	10030148	1/2 Eye Bolt	1
5	20020426	Clevis Weldment	1
6	90001367	5/8 NC x 5-1/2 Hex Bolt	1
7	90510079	Disc Blade	1
8	20021772	Hub	1
9	90101278	Bearing	2
10	20033351	Spacer Bushing	1
11	90001425	3/4 NC x 5-1/2 Hex Bolt	2
12	20030685	Back Plate	1
13	20030344	5/8 UBolt, 7" Inside, 8.5" Long	2
14	90001111	3/8 NC x 1-1/4 Hex Bolt	4
15	20031285	5/8 NC Eye Bolt	1
16	90011060	3/4 x 14 Ga. Nar. Rim Mach. Bushing	2
	20021773	Hub Assembly (Ref. 8-10)	1

REAR STABILIZER COULTER

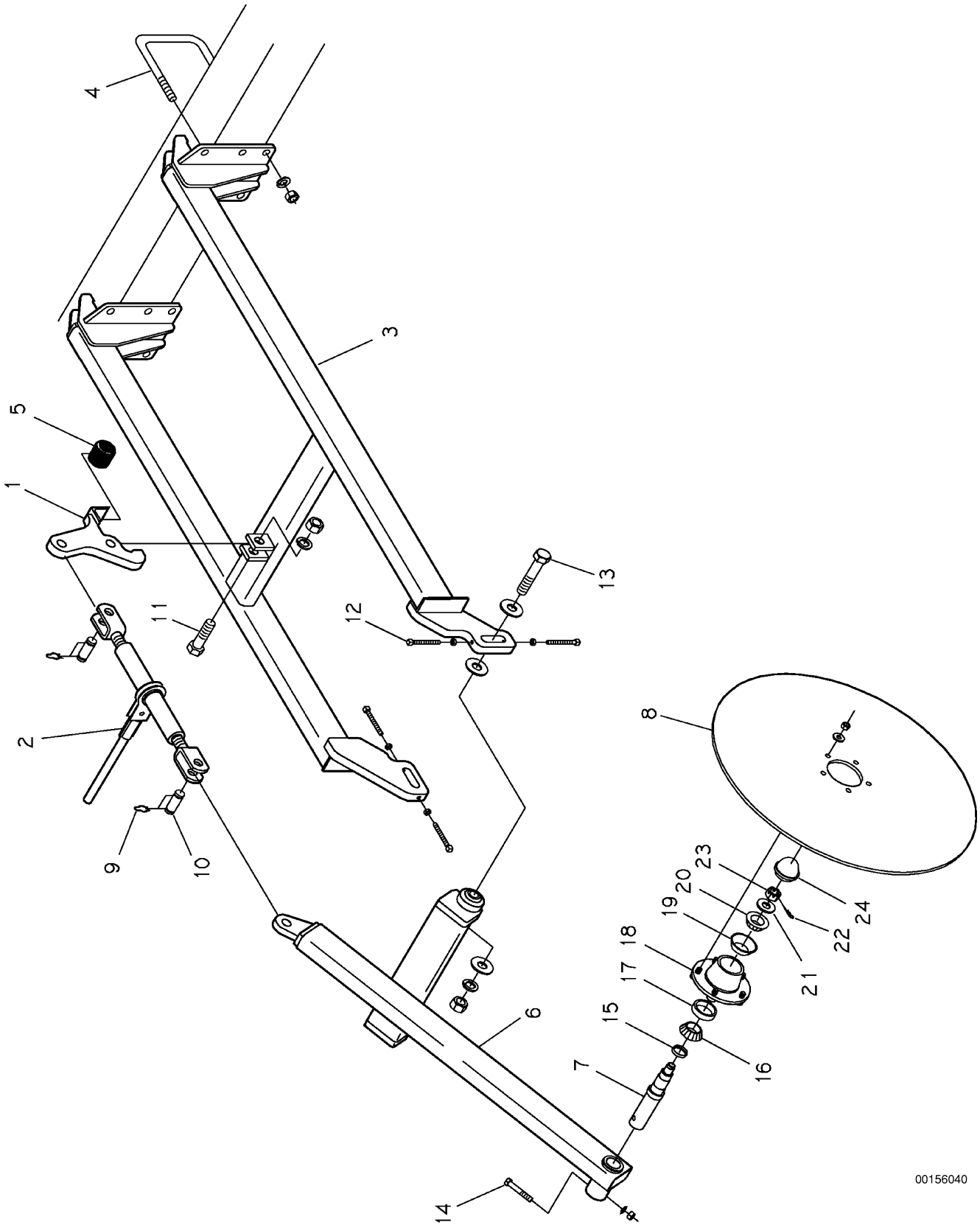

00156040

REAR STABILIZER COULTER

REF.	PART NO.	DESCRIPTION	QTY.
1	20020709	Arm Weldment	1
2	20020705	Ratchet Jack	1
3	20020706	Mounting Frame	1
4	20030345	3/4 UBolt, 7" Inside, 9.125 Long	4
5	20031313	Rubber Bushing	1
6	20020708	Strut	1
	90305035	1" Uniball (Welded in Strut)	1
7	20031314	Spindle	1
8	20020707	Disc Coultter	1
9	90025018	3/4 Ext. Hair Pin Clip	4
10	90042048	1 x 2-3/4 Clevis Pin	2
11	90002914	1 NC x 3-1/2 Hex Bolt	1
12	90016042	3/8 x 3-1/2 Sq. Head Set Screw	4
13	90001531	1 NC x 5 Hex Bolt	2
14	90001237	1/2 NC x 3 Hex Bolt	1
15	90109002	Seal for 1.750 Spindle Seal Area	1
	90109209	Seal for 1.700 Spindle Seal Area	1
16	90101023	Bearing Cone	1
17	90101022	Bearing Cup, Inner	1
18	90509003	5 Bolt Hub, with Cups	1
19	90101016	Bearing Cup, Outer	1
20	90101015	Bearing Cone	1
21	90509067	Washer, 7/8 x 2	1
22	90023043	Cotter Pin, 3/16 x 1-1/2	1
23	90006060	7/8 NF Slotted Hex Nut	1
24	90509009	Dust Cap	1
	20020710	Hub & Spindle (Ref. 7,15-24)	1
	10021051	Hub Assembly (Ref. 15,16,17,18,19,20,24)	1

ANHYDROUS HITCH

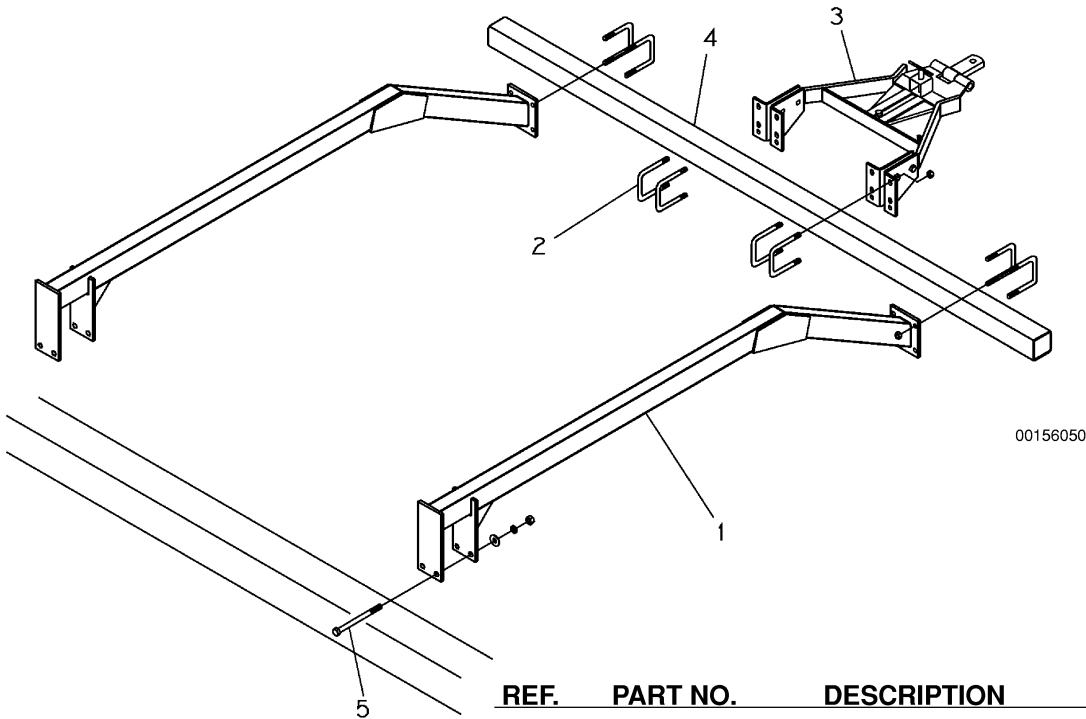

REF.	PART NO.	DESCRIPTION	QTY.
1	20021863	Mount Weldment	2
2	20031438	UBolt, 5/8 NC x 4 x 5-1/2 Long	8
3	20021181	Hitch Asm.	1
4	20033554	Cross Tube	1
5	90001441	3/4 NC x 9-1/2 Hex Bolt	4

ANHYDROUS ATTACHMENT

REF.	PART NO.	DESCRIPTION	QTY.
1	20021848	Setback Weldment,	1
2	20021849	Guide Block Weldment	1
3	20033512	Heavy Duty Tine	1
4	20033517	Anhydrous knife	1
5	90001109	3/8 NC x 1 Hex Bolt	4
6	90001221	1/2 NC x 1 Hex Bolt	2
7	90001227	1/2 NC x 1-3/4 Hex Bolt	2
8	90001229	1/2 NC x 2 Hex Bolt	4

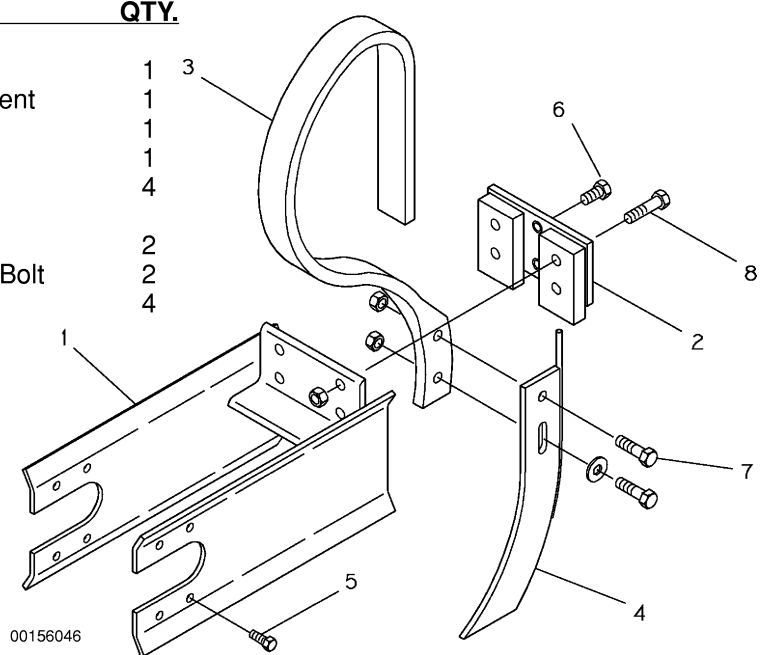

ROW GUIDE MARKERS

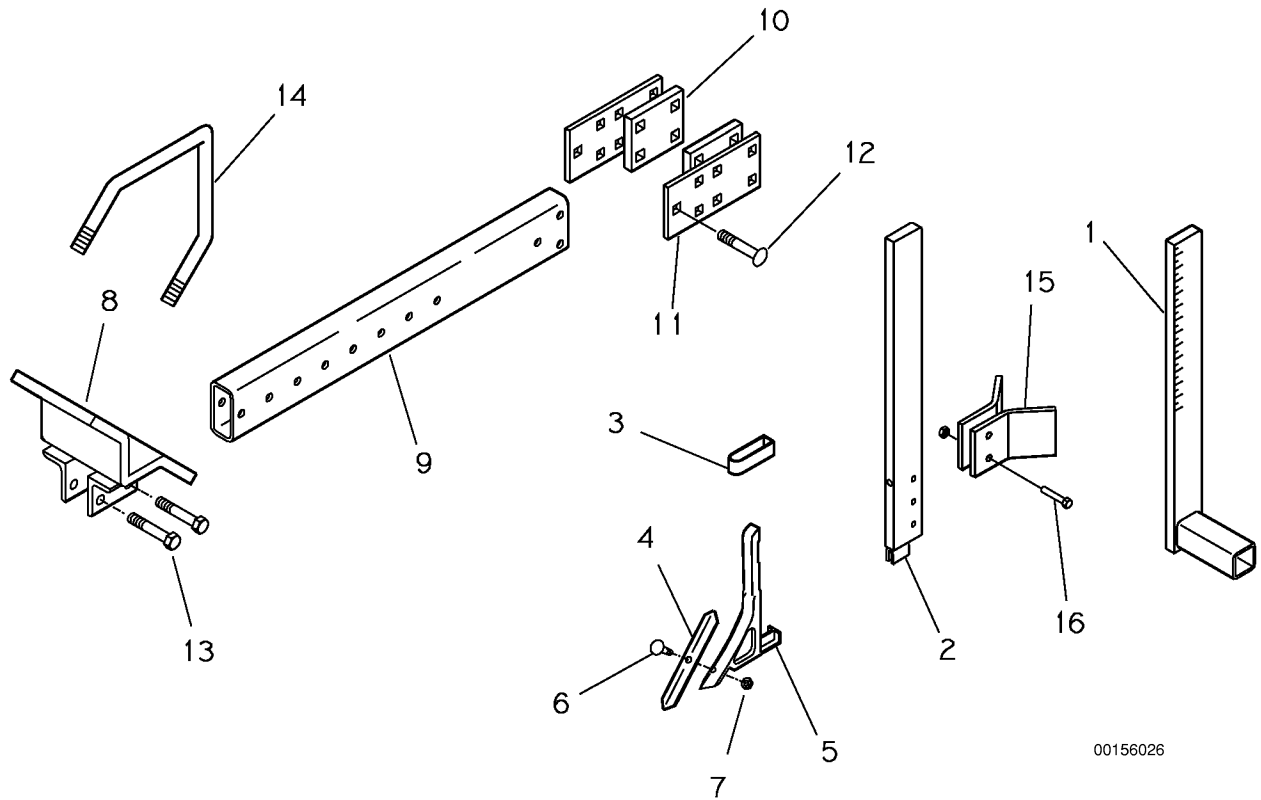

00156026

REF.	PART NO.	DESCRIPTION	QTY.
1	20520003	Shank, Spring Tine Marker	1
2	20020608	Shank, Row Guide, 3/4 x 2-1/2 x 24 Long	1
	20021061	Shank, Row Guide, 3/4 x 2-1/2 x 32 Long	1
3	20020607	Attaching Bracket	1
4	90510088	Spike Point	1
5	20031826	Row Guide Point, Replaceable Point	1
6	90001841	3/8 NC x 11/2 Plow Bolt	1
7	90006005	3/8 NC Hex Nut	1
8	20021690	Mount Weldment, Setback	1
9	20033128	Tube	1
10	20033127	Spacer, Plate	2
11	20033126	Plate, Shank Mount	2
12	90001792	5/8 NC x 3-1/2 Carriage Bolt	7
13	90001357	5/8 NC x 31/2 Hex Bolt	2
14	20031443	ABolt, 7/8 NC x 7 x 7	2
15	20033294	Cleanout Wing	2
16	90001117	3/8 NC x 2 Hex Bolt	2
	20020987	Row Guide Chisel and Point (Ref. 4-7)	1
	20020902	24" Row Guide Assembly (Ref. 2-7)	1
	20020903	32" Row Guide Assembly (Ref. 2-7)	1

ROW WEEDER DISCS

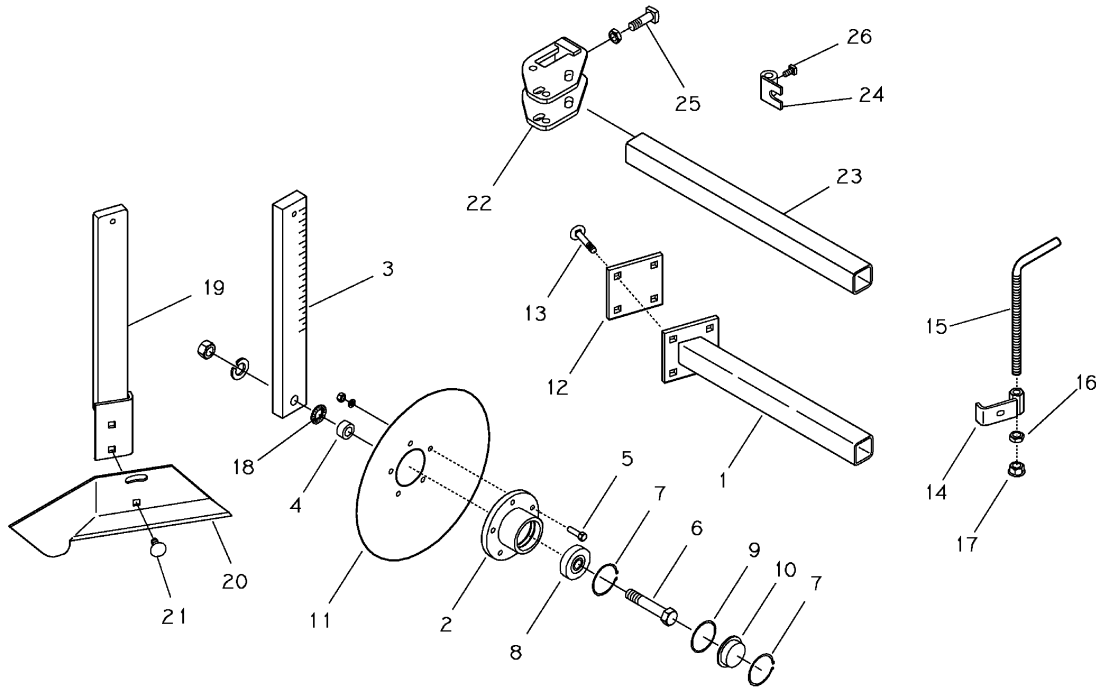

00156020

REF.	PART NO.	DESCRIPTION	QTY.
1	20021465	Tube Weldment, 30" Rows, 16-1/2 long	2
	20021464	Tube Weldment, 36"-40" Rows, 20-1/2 long	2
2	20021466	Hub	2
3	20032704	Shank	2
4	20032705	Spacer	2
5	90001111	3/8 NC x 1-1/4 Hex Bolt	10
6	90001411	3/4 NC x 3 Hex Bolt	2
7	90039046	Snap Ring	2
8	90101254	Bearing	2
9	90109206	O-Ring	2
10	90509118	Dust Cap	2
11	90510080	Disc	2
12	20032152	Cap, Tube	2
13	90001755	1/2 NC x 2-1/2 Carriage Bolt	8
14	20021418	Adjustment Nut	2
15	20032767	Crank	2
16	90006280	5/8 NC Jam Nut	2
17	90006145	5/8 NC Whiz Nut	2
18	90011190	3/4 Internal Star Washer	1
19	20021788	Clean Sweep Shank (LH) Shown	1
	20021787	Clean Sweep Shank (RH)	1
20	90510118	Shannon Clean Sweep (LH) Shown	1
	90510119	Shannon Clean Sweep (RH)	1
21	90001749	1/2 NC x 1 Carriage Bolt	2
22	20021876	Clamp Weldment	1
23	20033576	Tube	1
24	20021877	Bracket Weldment	1
25	90016095	5/8 NC x 2 Sq. Hd. Set Screw	1
26	90016031	5/8 NC x 3/4 Sq. Hd Set Screw	1
	20021813	Disk and Hub Assy.	1
	20021468	Shank, Disk, and Hub Assy.	1

COULTER DISC COMPONENTS

REF.	PART NO.	DESCRIPTION	QTY.
1	90510079	Disc	1
2	20021368	Disc Mount	1
3	20031447	UBolt, 1/2 NC x 2 x 4	2
4	20020699	Adjustable Tab	1
5	20021772	Hub, Machined	1
	20021773	Hub Assembly (5, 8, 9, 10)	1
6	90001111	3/8 NC x 1-1/4 Hex Bolt	4
7	90001367	5/8 NC x 5-1/2 Hex Bolt	1
8	9010278	Bearing	2
9	20033351	Spacer	1
10	9001060	3/4 X 14 Ga. Mach. Bushing	2
11	20021843	Disc Mount (Adjustable)	1

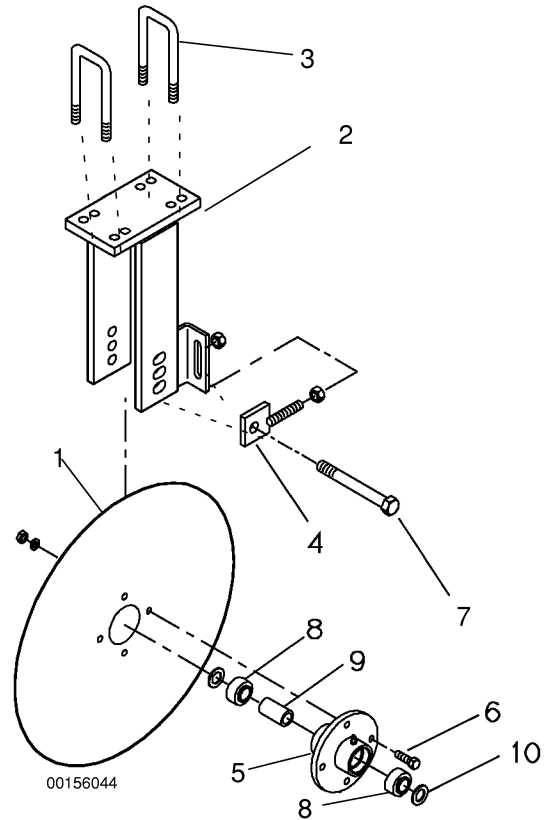

TUNNEL SHIELDS

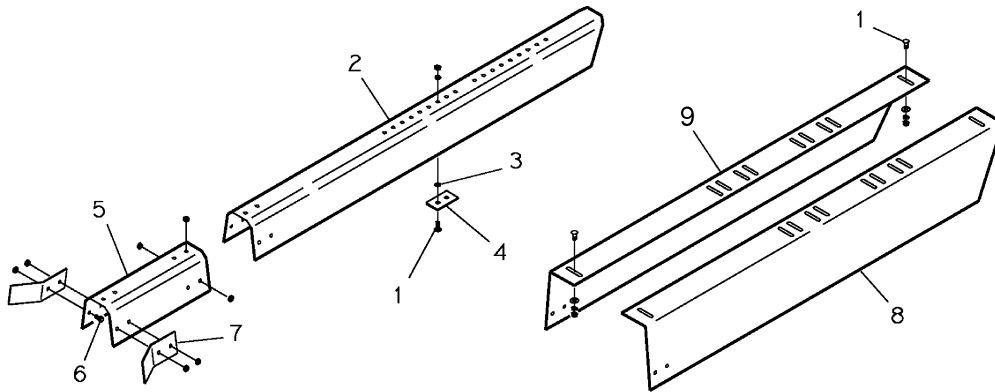

REF.	PART NO.	DESCRIPTION	QTY.
1	90001695	3/8 NC x 1 Carriage bolt	4
2	20032722	Tunnel Shield, (STD) Adjustable	1
	20032721	Tunnel Shield, (DEEP) Adjustable	1
3	20032725	3/8 Clip	4
4	20032724	Back Plate	2
5	20032620	Tunnel Shield Extension (STD)	1
	20032619	Tunnel Shield Extension (Deep)	1
6	90001105	3/8 NC x 3/4 Hex Bolt	2
7	20032880	Tunnel Sweep	2
8	20032922	Split Tunnel, RH	1
9	20032921	Split Tunnel, LH	1

GUIDE WHEEL, JSHANK

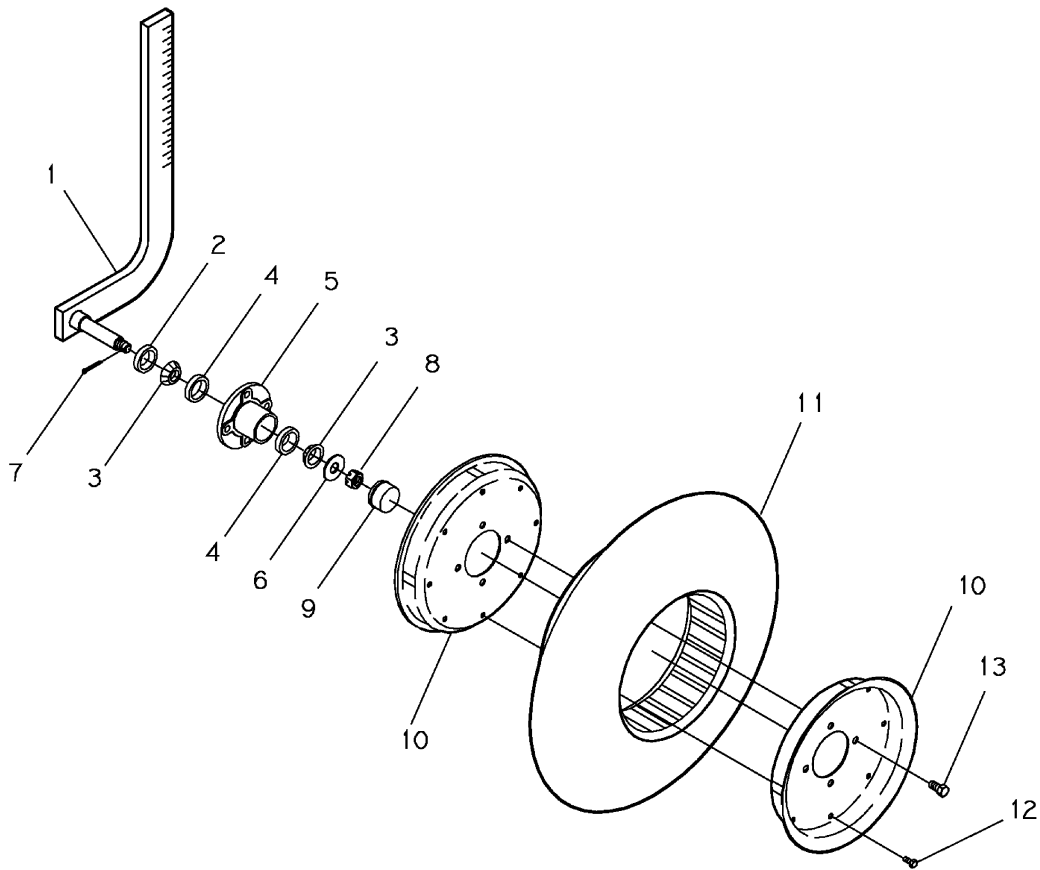

00208054

REF.	PART NO.	DESCRIPTION	QTY.
1	20021010	Strut (Left) 3/4 x 2-1/2	1
	20020894	Strut & Hub Assembly (Left)	1
	20021009	Strut (Right) 3/4 x 2-1/2 (Shown)	1
	20020893	Strut & Hub Assembly (Right)	1
	20021092	Strut, Hub & Wheel Assembly (Right)	1
2	90109063	Seal for 1.250 Spindle Seal Area	1
	90109207	Seal for 1.210 Spindle Seal Area	1
3	90101018	Bearing Cone	2
4	90101017	Bearing Cup	2
5	90509084	Hub	1
6	20020932	Hub Assembly (Ref. 25, 9)	1
	90509066	Washer, 3/4 ID x 1-3/4 OD	1
7	90023043	Cotter Pin, 3/16 x 1-1/2	1
8	90006058	Nut, 3/4 NF Slotted	1
9	90509033	Dust Cap	1
10	20031821	Rim Half	2
11	90509089	V-Tire, 4 x 16	1
	20021002	V-Tire Assembly	1
12	90001055	5/16 NC x 3/4 Hex Bolt	4
13	90001222	1/2 NF x 1 Hex Bolt	4

TOGGLE TRIP

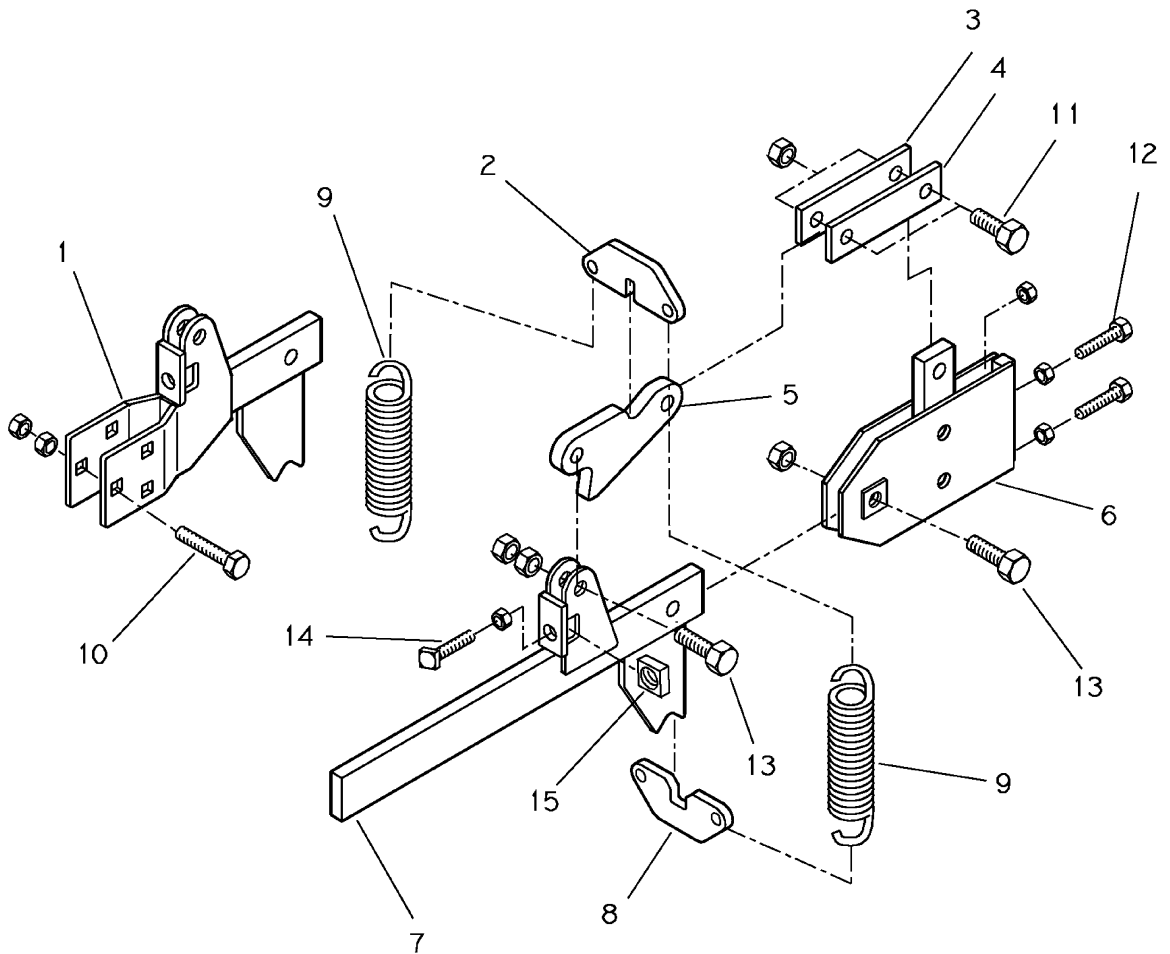

00156031

REF.	PART NO.	DESCRIPTION	QTY.
1	20020592	Toggle Trip, Tree Shank	1
2	20031038	Plate, Spring Attachment	1
3	20031034	Bar, Toggle Trip, No Threads	1
4	20031033	Bar, Toggle Trip	1
5	20031040	Ear	1
6	20020591	Toggle Trip Pivot, 3/4" Shank	1
7	20020593	Shank Weldment, Toggle Trip	1
8	20031036	Plate, Spring Attachment	1
9	20031745	Spring (Painted)	2
10	90001792	Carriage Bolt, 5/8 x 3-1/2	3
11	90001403	3/4 NC x 2 Hex Bolt	2
12	90016068	1/2 NC x 2-1/2 Sq. Head Set Screw	2
13	90001407	3/4 NC x 2-1/2 Hex Bolt	2
14	90016118	3/4 NC x 3-1/2 Sq. Head Set Screw	1
15	90006619	3/4 NC Square Nut	1
	20020590	Toggle Trip Assembly (Shank Mount)	1
	20020589	Toggle Trip Assembly (Tree Mount)	1

LIFT ASSIST

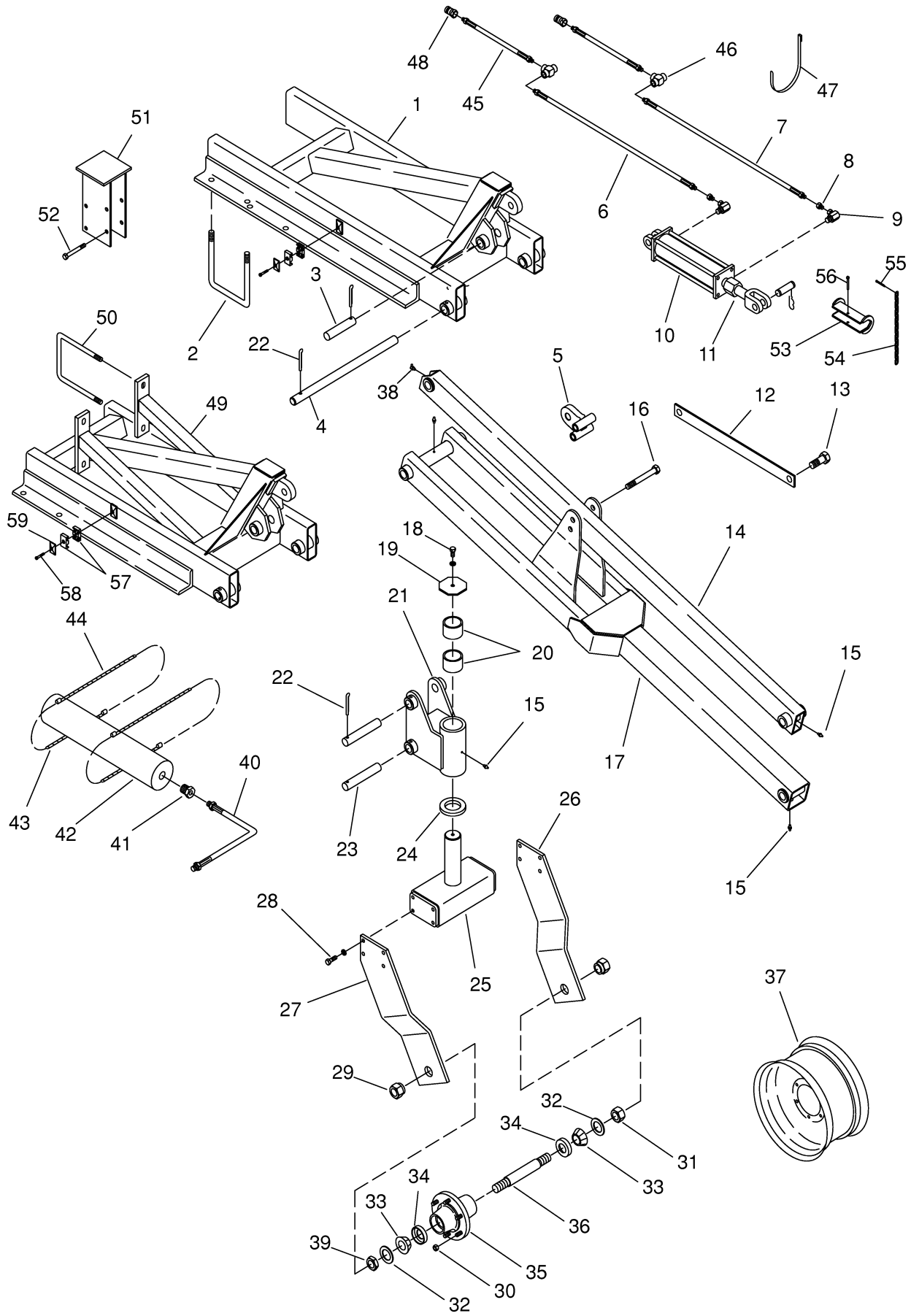

LIFT ASSIST

REF.	PART NO.	DESCRIPTION	QTY.
1	20021396	Frame Weldment	1
2	20030345	UBolt, 3/4 NC x 7" Inside x 9-1/8" Long	4
3	20031220	Pin, 1-1/4" OD x 5-3/4" Long	1
4	20031218	Pin, 1-1/4" OD x 21-1/2" Long	1
	20033069	Pin, 1-1/4" OD x 27-1/2" Long (1991 and 1992)	1
5	20020685	Ear Weldment	1
6	21020180	3/8 Hose, 1/2 MP x 1/2 MP x 111 (Single Lift Assist)	1
	21020172	3/8 Hose, 1/2 MP x 1/2 MP x 134 (Double Lift Assist)	2
7	21020192	3/8 Hose, 1/2 MP x 1/2 MP x 96 (Single Lift Assist)	1
	21020181	3/8 Hose, 1/2 MP x 1/2 MP x 122 (Double Lift Assist)	2
8	90501531	Restrictor, 1/2" Swivel, 1/16"	2
9	90501528	Elbow, 3/4-16 MORB, 1/2 FPT x 90 Deg.	2
10	90521302	Hydraulic, Cylinder, 3-1/2 x 8 Stroke	1
	90521380	Seal Kit, Hydraulic Cylinder	1
11	90521704	Depth Stop Nut	1
12	20032687	Strap, Cylinder	1
13	90001511	1 NC x 2 Hex Bolt	2
14	20021553	Upper Tube Weldment	1
	20020687	Upper Tube Weldment (Prior 1991)	1
15	90515024	Zerk, Straight, 1/4-28 UNF	5
16	90001427	3/4 NC x 6 Hex Bolt	2
17	20021798	Tube Weldment	1
18	90001221	1/2 NC x 1 Hex Bolt	1
19	20031219	Retainer Plate	1
20	20031766	Bushing	2
21	20020968	Pivot Weldment (Replacement Parts Order Pivot Assembly)	1
	20020900	Pivot Assembly with Bushings	1
22	90023084	3/8 x 3-1/2 Cotter Pin	4
23	20031241	Pin, 1-1/4" OD x 7-3/4" Long	2
24	20031233	Thrust Bearing	1
25	20020689	Caster Pivot Weldment	1
26	20032622	Plate, Side (Right)	1
27	20032621	Plate, Side (Left)	1
28	90001225	1/2 NC x 1-1/2 Hex Bolt	8
29	20031847	1-1/4 NF Shoulder Nut	2
30	90509011	Wheel Nuts, 1/2 NF	6
31	90006024	1-1/4 NF Hex Nut	2
32	90109127	Seal	2
33	90101149	Bearing Cone	2
34	90101148	Bearing Cup	2
35	90509082	Hub with Cups	1
36	20031240	Spindle Fork	1
37	90509077	Rim, 15" x 6 x 6 Hole	1
38	90515026	Zerk, 1/4-28 UNF x 45 Deg.	1
39	20032726	Nut, Short, 11/4 NF	1
40	21020251	1/2 Hose, 1/2 MP/MPX x 24	1
41	90501145	Bushing, 1x 1/2 NPT	1
42	20021200	Accumulator	1
43	90031043	Hose Clamp, Worm #28	2

LIFT ASSIST

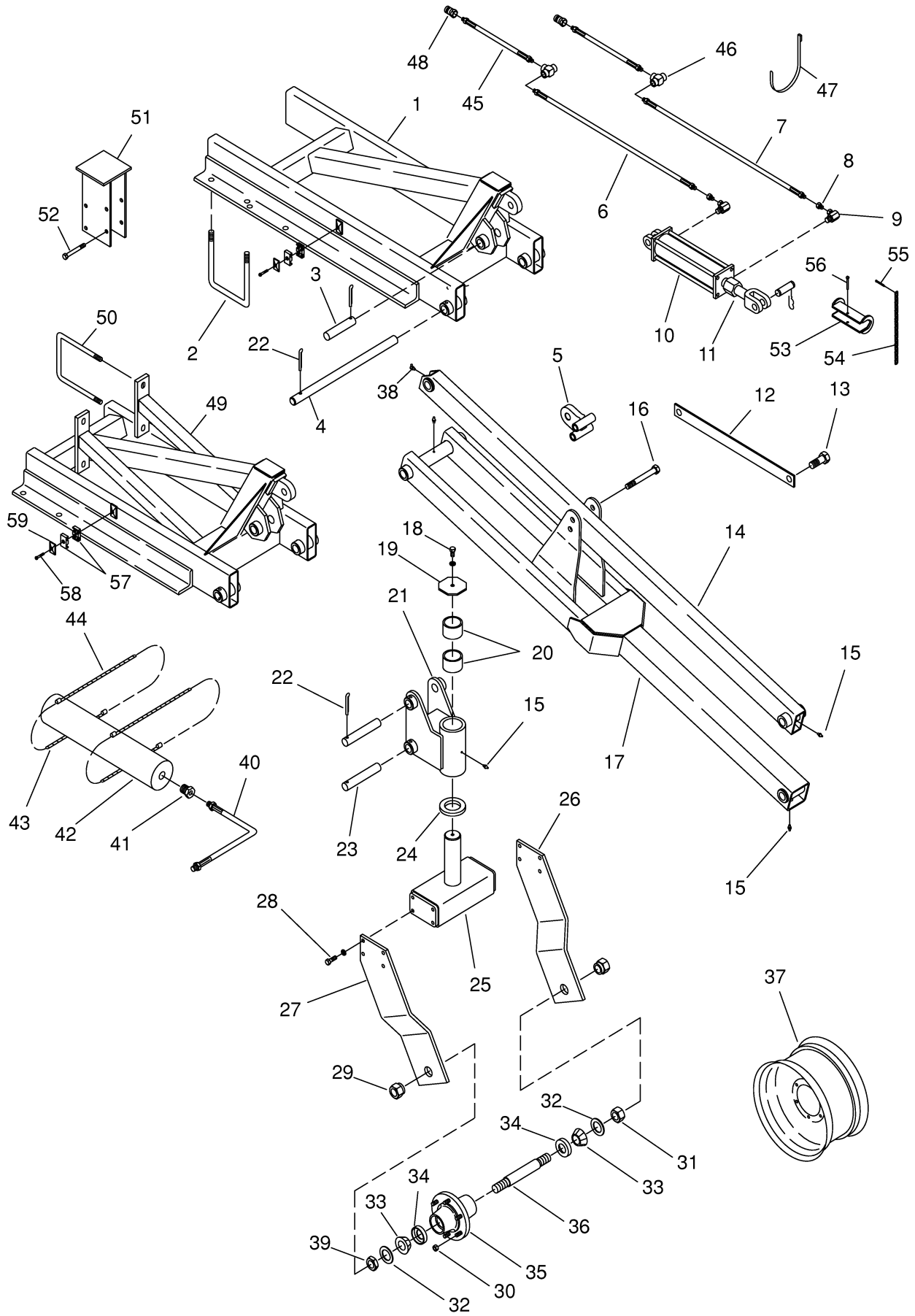

LIFT ASSIST

REF.	PART NO.	DESCRIPTION	QTY.
44	90031039	Hose Clamp, Worm #88	2
45	21020183	3/8 Hose, 1/2 MP x 1/2 MP x 60 (Double Lift Assist)	2
46	90501358	Tee, 1/2 NPT (Steel)	2
47	90507086	32" Cable Tie	6
48	90519003	Quick Coupler, Male Tip	2
49	20021792	Frame Weldment (TRF)	1
50	20030344	UBolt, 5/8 NC x 7 x 8.5 Long	2
51	20021807	Standoff, Linkage (3030)	1
52	90001245	1/2 NC x 4 Hex Bolt	3
53	20022059	Cylinder Stop	1
54	12030472	Chain	1
55	90023043	3/16 x 1-1/2 Cotter Pin	2
56	90042055	Lock Pin, 1/4 x 2-1/4	1
57	90031069	Clamp Body	1
58	90031068	Cover Plate	1
59	90002356	5/16 x 1-3/4 Hex Bolt	1
	20020928	Hub & Spindle Assembly (Ref. 29-36, 39)	1
	90509077	Tire, 9.5L X 15	1

HILLER ATTACHMENT

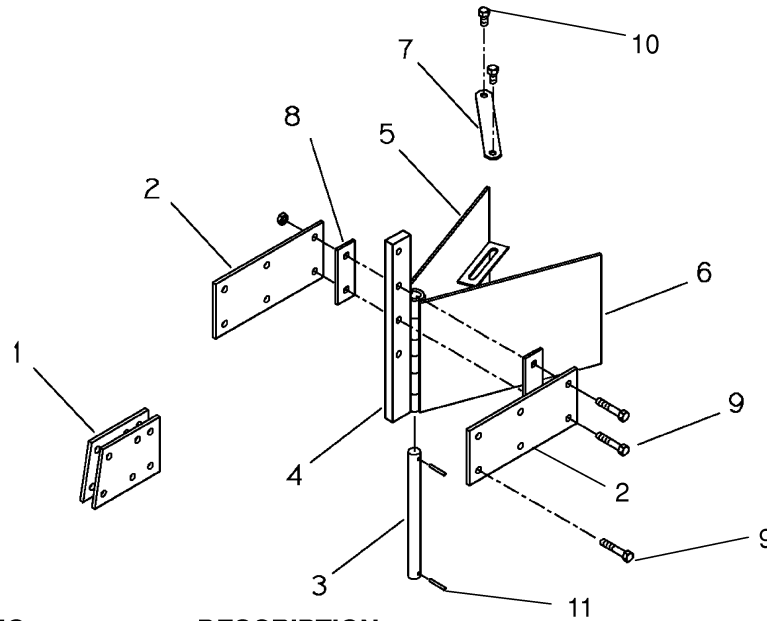

00156045

REF.	PART NO.	DESCRIPTION	QTY.
1	20033058	Side Plate (Straight Edge Tine)	2
2	20033073	Side Plate (Shank)	2
3	20033072	Pin, Hinge	1
4	20021643	Hinge Weldment	1
5	20021644	Wing Weldment R.H.	1
6	20021645	Wing Weldment L.H.	1
7	20033057	Strap	1
8	20033074	Spacer Plate (Shank)	2
9	90001117	3/8 NC x 2 Hex Bolt (Shank)	6
	90001113	3/8 NC x 1-1/2 Hex Bolt (Straight Edge Tine)	6
10	90001105	3/8 NC x 3/4 Hex Bolt	2
11	90029132	3/16 x 1-1/4 Roll Pin	2

LIFT ASSIST

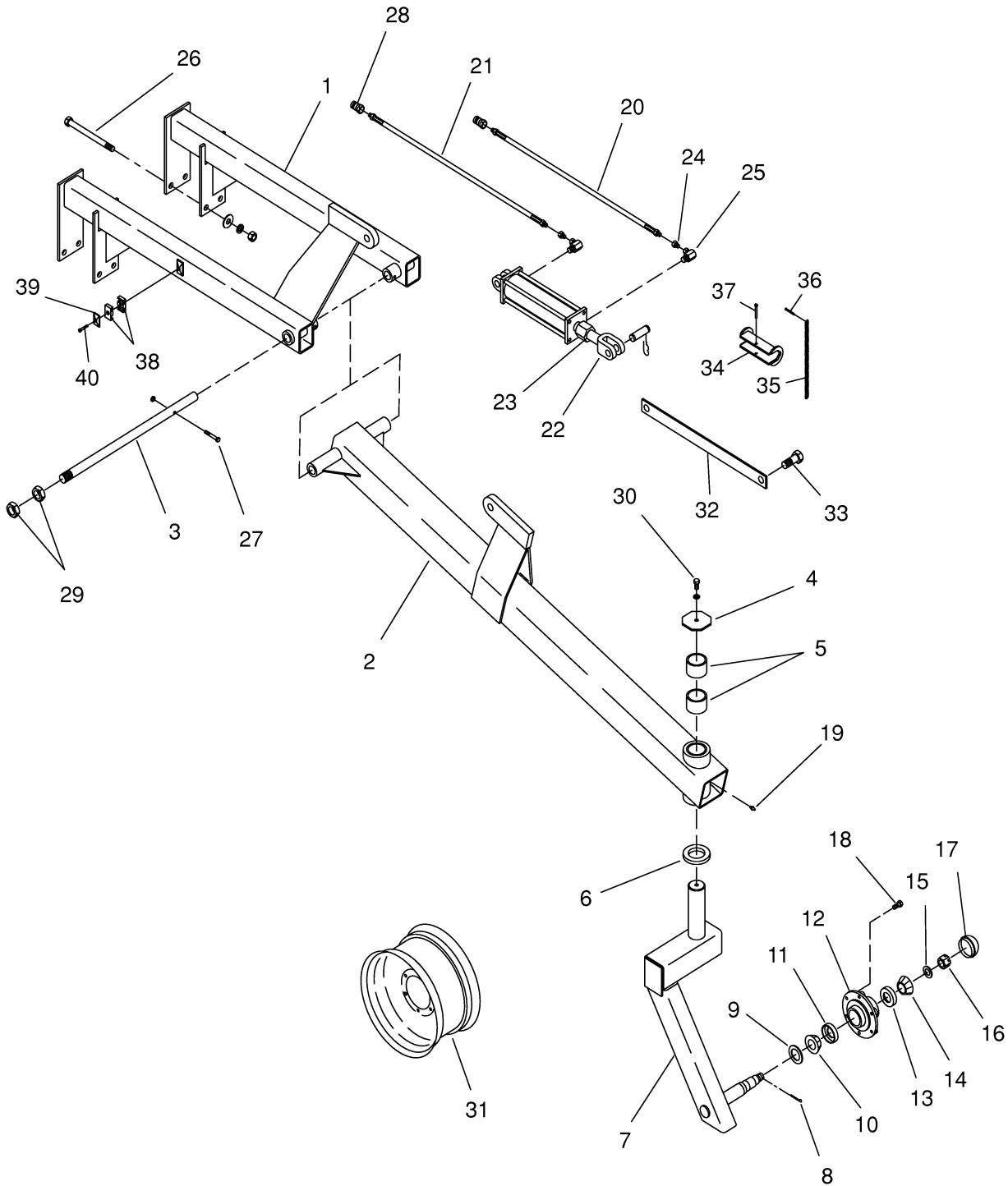

LIFT ASSIST

REF.	PART NO.	DESCRIPTION	QTY.
1	20021519	Mount Weldment	1
2	20021518	Tube Weldment	1
3	20032799	Axle	1
4	20031219	Retainer Plate	1
5	20031766	Bushing	2
6	20031233	Thrust Bearing	2
7	20021517	Castor Weldment	1
8	90023045	3/16 x 2 Cotter Pin	1
9	90109002	Seal	1
10	90101025	Bearing Cone	1
11	90101024	Bearing Cup	1
12	90509004	6 Bolt Hub (with Cups)	1
13	90101016	Bearing Cup	1
14	90101015	Bearing Cone	1
15	90509068	Washer	1
16	90006062	1" NF Slotted Hex Nut	1
17	90509009	Dust Cap	1
18	90509010	Wheel Bolt, 1/2 NF x 1-1/16	6
19	90515024	Zerk, Straight, 1/4-28 UNF	1
20	21020180	3/8 Hose, 1/2 MP x 1/2 MP x 111	1
21	21020192	3/8 Hose, 1/2 MP x 1/2 MP x 96	1
22	90521391	Hydraulic Cylinder, 3 x 10 Stroke	1
23	90521305	Mech. Depth Stop Nut	1
24	90501531	1/2" Swivel Restrictor, 1/16	2
25	90501528	Elbow, 3/4-16 MORB, 1/2 FPT x 90 Deg.	2
26	90001441	3/4 NC x 9-1/2 Hex Bolt	4
27	90001121	3/8 NC x 2-1/2 Hex Bolt	1
28	90519003	Quick Coupler, Male Tip	2
29	90006291	1-1/4 NF Hex Jam Nut	2
30	90001221	1/2 NC x 1 Hex Bolt	1
31	90509077	Rim, 15" x 6" x 6 Hole	1
32	20032687	Strap, Cylinder	1
33	90001515	1 NC x 2 1/2 Hex Bolt	2
34	20022059	Cylinder Stop	1
35	12030472	Chain	1
36	90023043	3/16 x 1-1/2 Cotter Pin	2
37	90042055	Lock Pin	1
38	90031069	Clamp Body	1
39	90031068	Cover Plate	1
40	90002356	5/16 x 1-3/4 Hex Bolt	1
	20021549	Caster Assembly w/hubs (Ref. 7-18)	1

MOUNTS (SHIELDS)

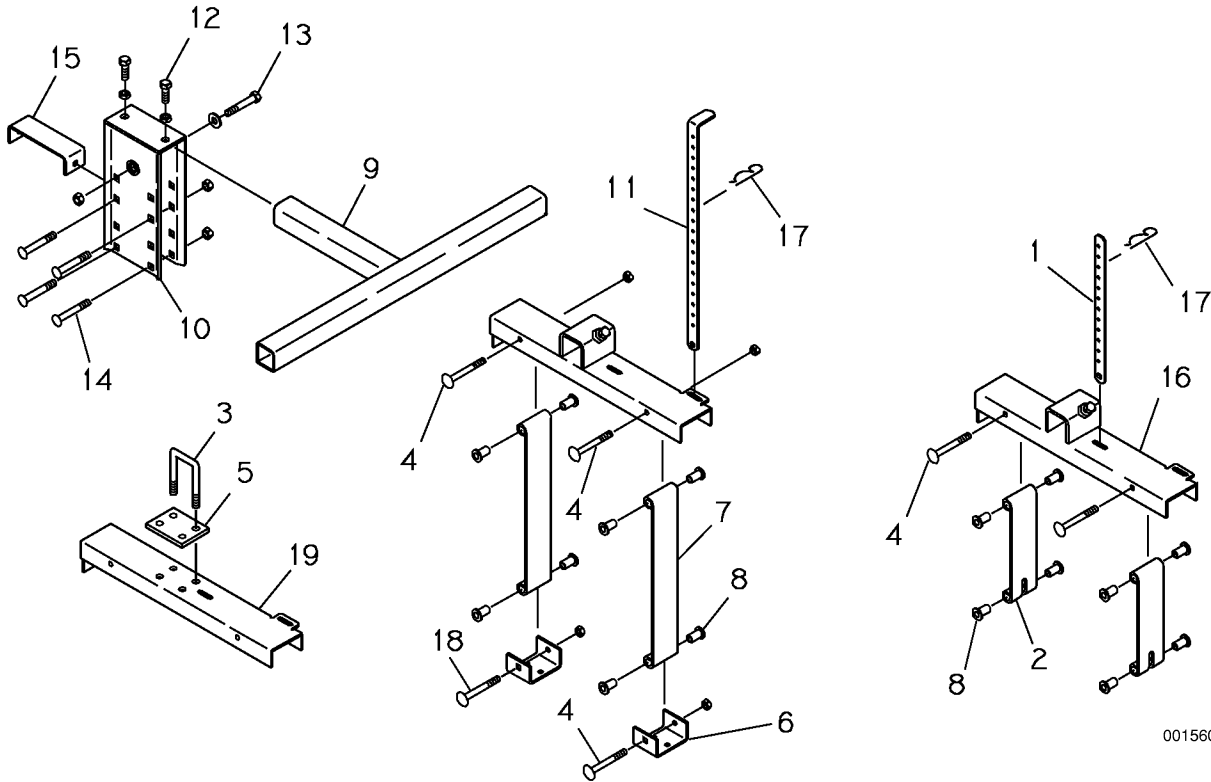

00156024

REF.	PART NO.	DESCRIPTION	QTY.
1	20030928	Adjustment Strap	1
2	20033042	Pivot Strap (Center Mount)	2
	20021640	Pivot Strap with Bushings (Center Mount)	2
3	20032954	UBolt, 1/2 NC x 2 x 3-1/2 long	2
4	90001736	7/16 NC x 4 Carriage Bolt	3
5	20033356	Spacer	1
6	20032723	Bracket, Tunnel	2
7	20032912	Pivot Strap (Model 2130)	1
	20021590	Pivot Strap with Bushings (Model 2130)	1
8	20032913	Bushing	4
9	20021558	Tee Weldment (22" Rows) 29" Tube	1
	20021571	Tee Weldment (30" Rows) 35-1/2" Tube	1
	20021778	Tee Weldment (30" Rows) 35-1/2" Tube (Short)	1
	20021625	Tee Weldment (40" Rows) 45-1/2" Tube	1
10	20021555	Slide Weldment	1
11	20032910	Adjustment Strap (Model 2130)	1
12	90001225	1/2 NC x 1-1/2 Hex Bolt	2
13	90001241	1/2 NC x 3-1/2 Hex Bolt	1
14	90001759	1/2 NC x 3-1/2 Carriage Bolt	4
15	20033043	Space	1
16	20021652	Center Mount Bracket	1
17	90025007	Hair Pin Cotter, 3/16	2
18	90001737	7/16 NC x 4 Carriage Bolt	1
19	20033357	Tunnel Mount Bracket	1

PARKING STAND

FRONT PARKING STAND (Two used on all cultivators)

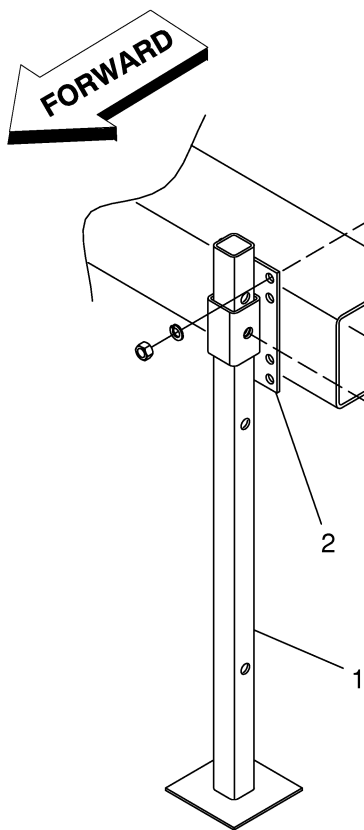

REAR PARKING STAND

(Two used on all folding toolbar cultivators without lift assist wheels)

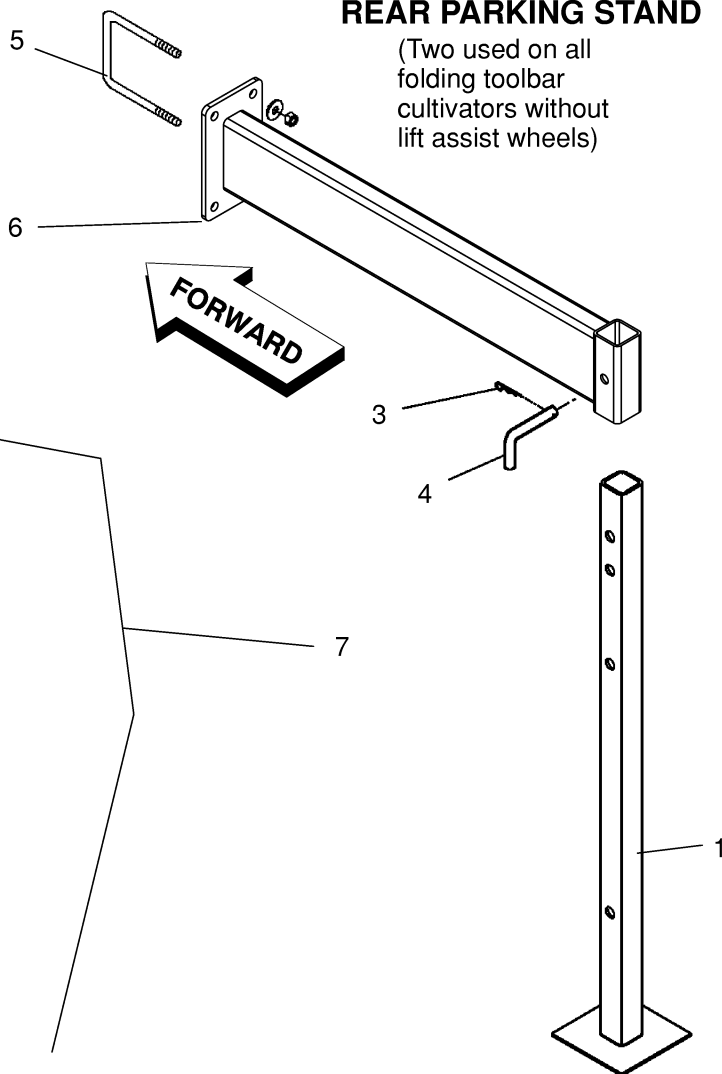

REF.	PART NO.	DESCRIPTION	QTY.
1	20021885	Parking Stand	1
2	20021886	Mounting Plate	1
3	90025005	5/32 Hair Pin Cotter	1
4	50530279	Pin	1
5	20030344	5/8 U-bolt, 7" Inside, 8-1/2" Long	2
6	20022028	Rear Parking Stand Extension	1
7	20021887	Front Parking Stand Assembly (Includes Ref. 1, 2, 3 and 4)	1

ROLLING SHIELDS

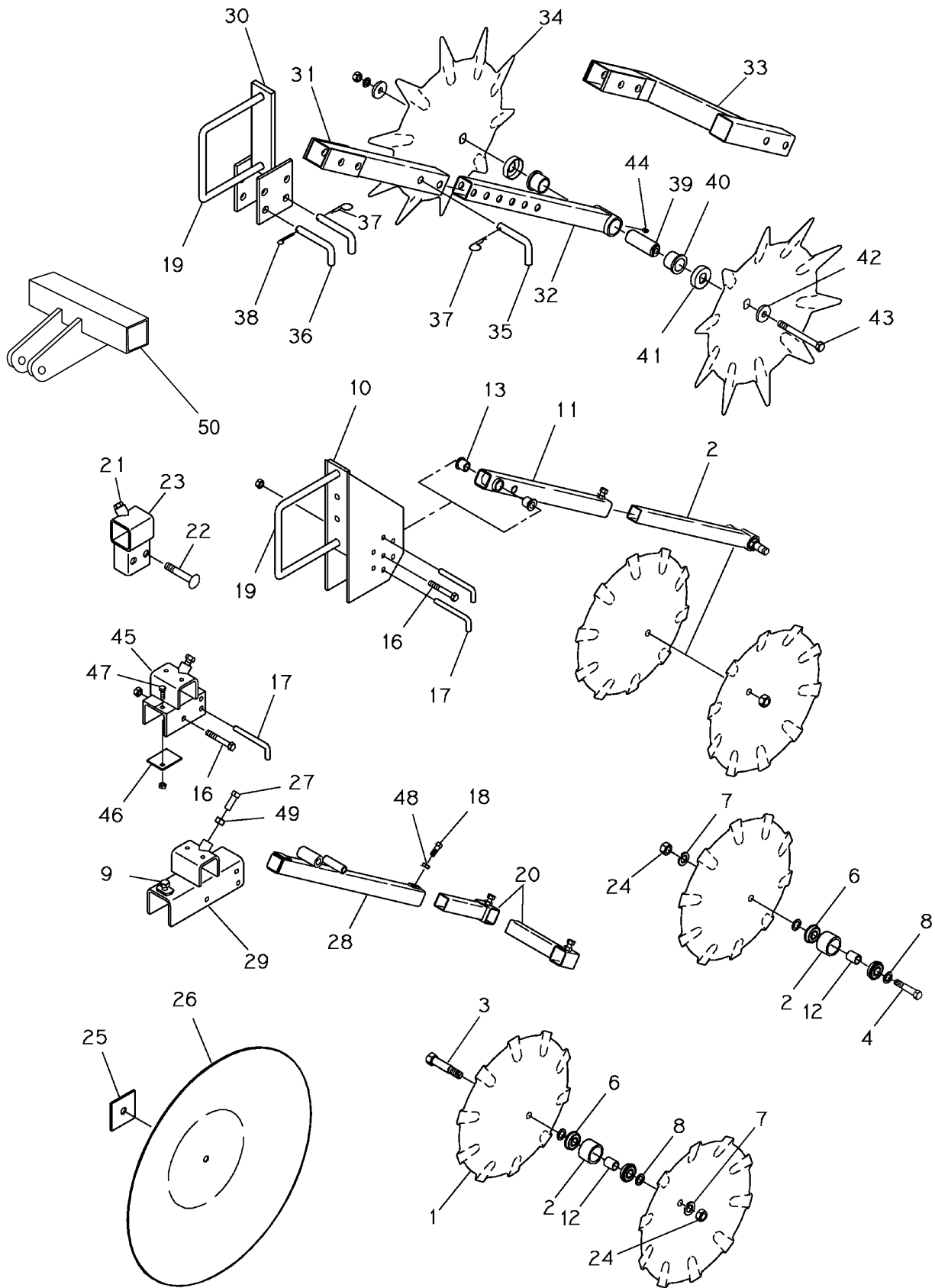

ROLLING SHIELDS

REF.	PART NO.	DESCRIPTION	QTY.
1	20033287	Rolling Shield, Painted	4
2	20021714	Mount Weldment	3
3	90001357	Bolt, Axle	2
4	90001349	Bolt, Axle	1
6	90101334	Bearing	4
7	90011015	5/8 Lockwasher	2
8	20033508	Washer	2
9	90003454	1/2 NC x 3 Hex Bolt, Full Thread	1
10	20021646	Mount Weldment	1
11	20021647	Pivot Tube Weldment	1
12	20034138	Spacer	2
13	20032913	Bushing	1
16	90001195	7/16 NC x 4 Hex Bolt	1
17	90025024	7/16 x 3 Hitch Pin	2
18	90016033	3/8 x 1 Sq. Head Set Screw	1
19	20030344	UBolt, 5/8 NC x 7 x 8.6 Long	1
20	20021648	Offset Tube Weldment	2
21	90001227	1/2 NC x 1-3/4 Hex Bolt	1
22	90001792	5/8 NC x 3-1/2 Carriage Bolt	2
23	20021844	Shield Mount Weldment	1
24	90006013	5/8 Hex Nut	1
25	20033326	Plate, Spacer	2
26	20033305	Disc, 24"	1
27	90016064	1/2 NC x 1-1/2 Sq. Head Set Screw	2
28	20021816	Pivot Tube Weldment	1
29	20021815	Rolling Shield Bracket (3030)	1
30	20021839	Mount Weldment	1
31	20021823	Upper Tube Weldment	1
32	20021827	Lower Tube Weldment	1
33	20021838	Offset Bracket	1
34	35521021	Rolling Shield	2
35	50530279	Pin	1
36	10034039	Pin	2
37	90025005	5/32 Hair Pin Cotter	2
38	90023034	5/32 x 1-1/4 Hair Pin Cotter	1
39	35521005	Axle	1
40	35521004	Bearing	2
41	35521015	Dust Cap	2
42	35521003	Washer	2
43	90001249	1/2 NC x 9 Hex Bolt	1
44	90515024	Zerk, Straight, 1/4 28 UNF	1
45	20021759	Rolling Shield Bracket	1
46	20033320	Shim	2
47	90001059	5/16 NC x 1 Hex Bolt	1
48	90006270	3/8 Jam Nut	1
49	90006276	1/2 Jam Nut	1
	20021846	Double Bearing Assembly (Ref. 2,4,5,6,7,8,12 and 24)	1
	20021847	Single Bearing Assembly (Ref. 2,3,6,7,8 and 24)	1
50	20021927	Fixed Shield Mount	1

END SHIELDS & OPEN TOP SHIELDS

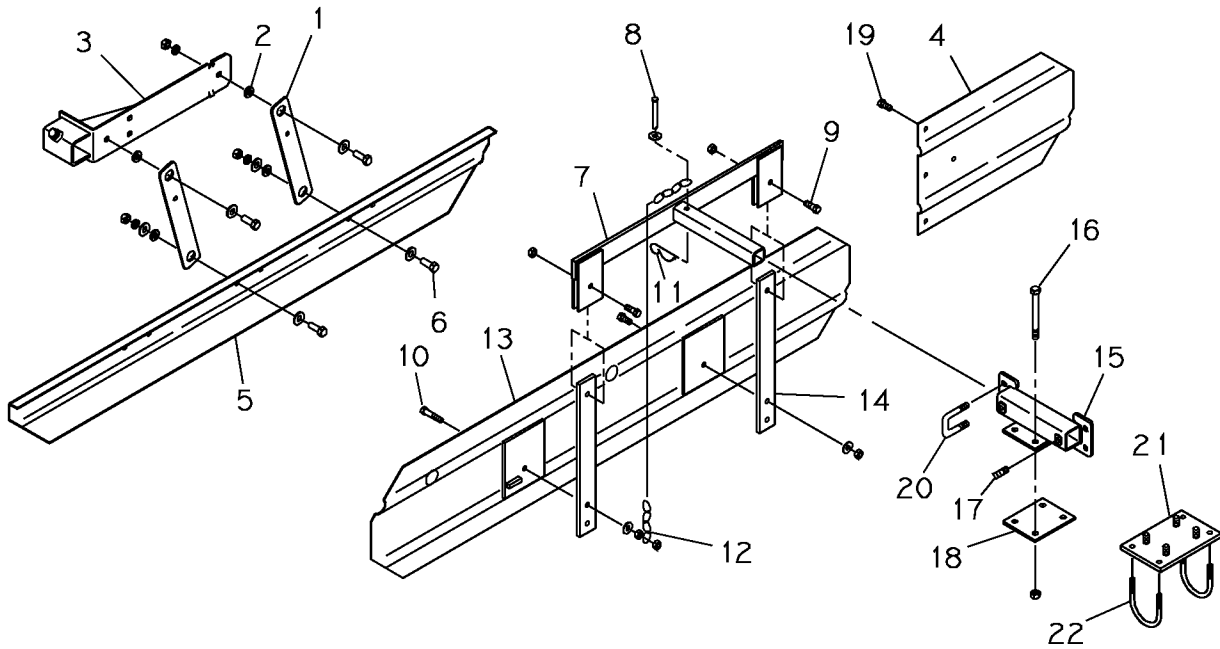

00156015

REF.	PART NO.	DESCRIPTION	QTY.
1	20030979	Pivot Arm	2
2	20033511	Spacer, Drilled	4
3	20020557	Support Bracket	1
4	20033238	Shield Extension	2
5	20032717	End Shield	1
6	90001223	1/2 NC x 1-1/4 Hex Bolt	4
7	20021602	Bracket Weldment, 30" Rows	1
	20021621	Bracket Weldment, 22" Rows	1
	20021841	Bracket Weldment, 36" to 40" Rows	1
8	90042026	3/8 x 2-3/4 Clevis Pin	1
9	90001173	7/16 NC x 1-1/4 Hex Bolt	3
10	90001179	7/16 NC x 2 Hex Bolt	1
11	90025004	1/8 Hair Pin Cotter	1
12	20032964	Chain	1
13	20021599	Shield Weldment, LH (Shown)	1
	20021600	Shield Weldment, RH (Not Shown)	1
14	20032957	Parallel Arm	2
	20033519	Parallel Arm (3030)	2
15	20021620	Outer Tube Weldment, 22" Rows	1
	20021601	Outer Tube Weldment, 30" Rows	1
	20021842	Outer Tube Weldment, 36" to 40" Rows	1
	20021822	Outer Tube Weldment, Open Top End Shield	1
16	90001237	1/2 NC x 3 Hex Bolt (2 x 2 Trees)	4
	90001249	1/2 NC x 5 Hex Bolt (2 x 4 Trees)	4
17	90016064	1/2 NC x 1-1/2 Sq. Head Set Screw	2
18	20032966	Back Plate	1
19	90001109	3/8 NC x 1 Hex Bolt	4
20	20033323	UBolt, 1/2 NC x 1-1/2 x 2-1/2 Long	2
21	20021758	Plate Weldment, Spider Gang	1
22	10032897	3/8 Round, U-Bolt 3" ID	2

SPRAY FENDER SPRAY KIT

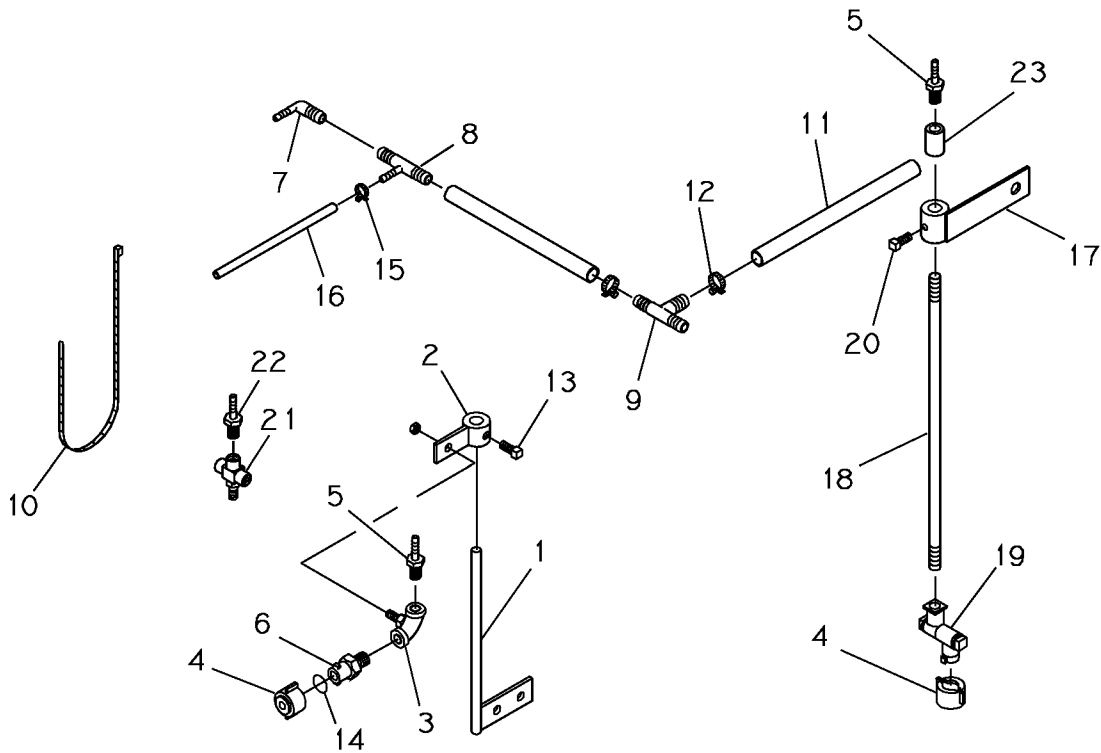

00156018

REF.	PART NO.	DESCRIPTION	QTY.
1	20021545	Rear Mounting Bracket	2
2	20021595	Mounting Bracket	2
3	20021594	Elbow Weldment	2
4	90527083	Q.J. Cap, Flat, Yellow	3
5	90527385	I.M.A. 1/4 x 1/4 Hose Barb, Steel	2
6	90527081	Q.J. Body, 1/4 MPT	2
7	90527386	Elbow, 1/4 HB x 1/2 HB	1
8	90527387	Tee, 1/4 x 1/2 x 1/2 Hose Barb	1
9	90527032	Tee, 1/2 HB	1
10	90507085	15" Plastic Cable Tie	1
	90507086	32" Plastic Cable Tie	1
11	90506020	Hose, 1/2 EPDM	A/R
12	90031045	Hose Clamp, Wire, 1/2 EVA	1
13	90001109	3/8 NC x 3/4 Hex Bolt	2
14	90527082	O-Ring, Quick Jet	A/R
15	90031063	Hose Clamp, 1/4"	1
16	90506019	Hose, 1/4" ,EPDM	A/R
17	20021789	Bracket Weldment, Lay By Nozzle	1
18	20033447	Tube	1
19	90527119	Swivel Body, 1/4 FPT (Brass)	1
20	90016031	3/8 NC x 3/4 Sq. Head Set Screw	1
21	20021821	Tee Weldment, 1/4 NPT	1
22	90527384	I.M.A. 1/4 x 1/4 Hose Barb, Plastic	3
23	90501187	Coupling, 1/4 NPT	2

SPRAY FENDER COMPONENTS

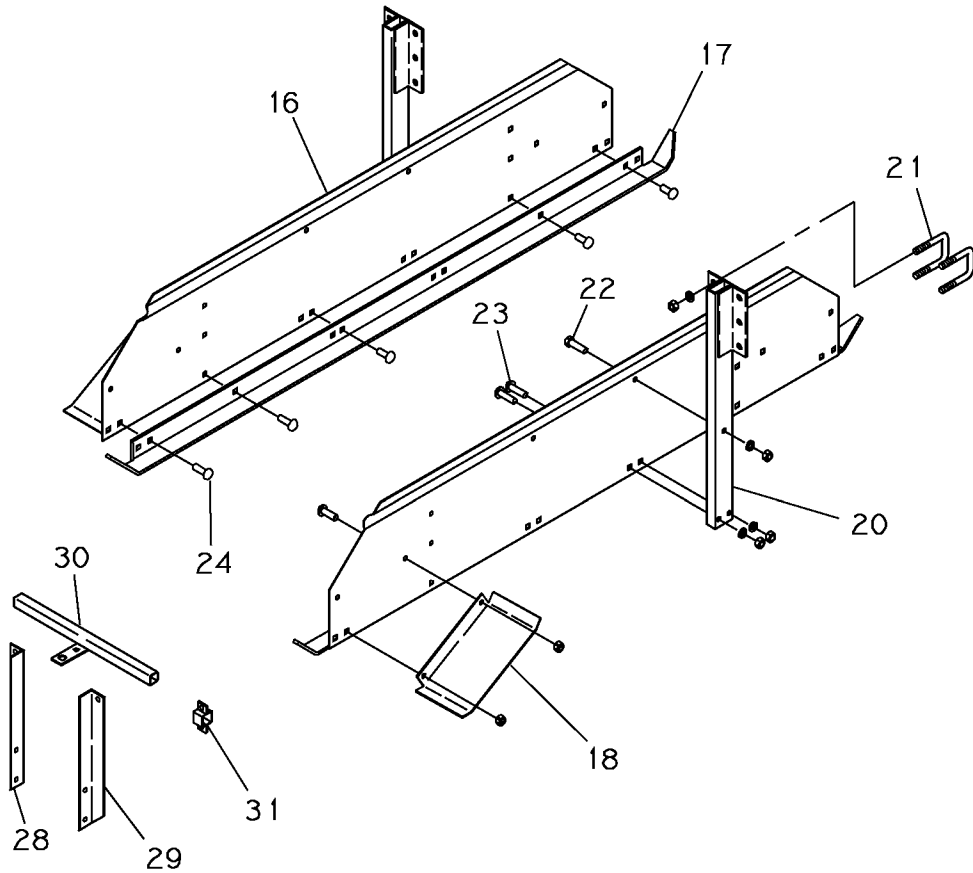
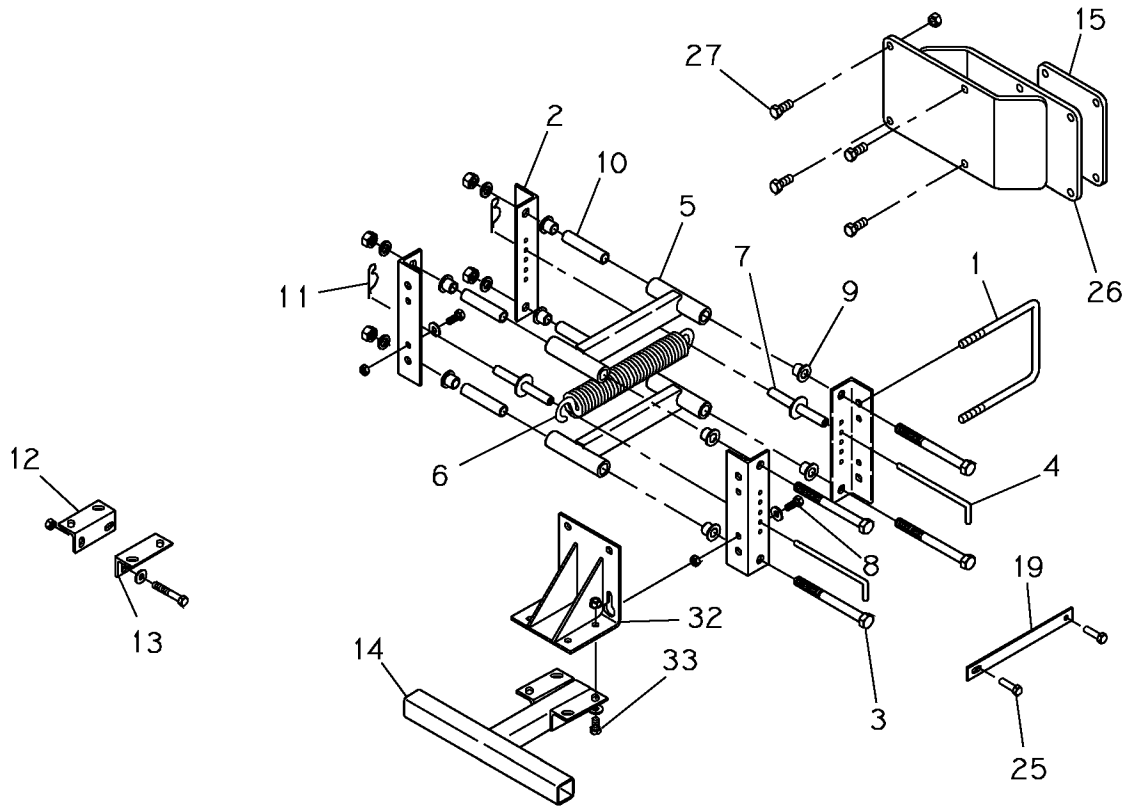

00156017

SPRAY FENDER COMPONENTS

REF.	PART NO.	DESCRIPTION	QTY.
1	20030344	UBolt, 5/8 NC x 7 x 8.5 Long	2
2	20032841	Mounting Angle	4
3	90001435	3/4 NC x 8 Hex Bolt	4
4	20032931	Pin	2
5	20021535	Parallel Tube Weldment	2
6	20033010	Spring	1
7	20021587	Anchor Tube Weldment	2
8	90001223	1/2 NC x 1-1/4 Hex Bolt	4
9	20030877	Bushing, Oilite	8
10	20032832	Bushing	4
11	90025005	Hair Pin Cotter, 5/32	2
12	20033076	Angle, LH (Prior 1994)	1
13	20033075	Angle, RH (Prior 1994)	1
14	20021819	Tube Weldment	1
15	20033151	Spacer Plate	1
16	20032829	Fender Shield	2
17	20032839	Skid	2
18	20032840	Shoe	2
19	20033327	Bar	1
20	20021540	Tube Shield Mounting	2
21	20030801	UBolt, 1/2 NC x 2 x 3 Long	4
22	90001115	3/8 NC x 1-3/4 Hex Bolt	2
23	90001698	3/8 NC x 1-3/4 Carriage Bolt	4
24	90001695	3/8 NC x 1 Carriage Bolt	10
25	90001109	3/8 NC x 1 Hex Bolt	4
26	20021543	Offset Bracket	1
27	90001341	5/8 NC x 1-1/2 Hex Bolt	4
28	20032927	Mounting Angle, Rear Nozzle (Left)	1
29	20032929	Mounting Angle, Rear Nozzle (Right)	1
30	20021820	Tube Weldment, Rear Nozzle	1
31	90527379	Clamp	2
32	20021651	Bracket Weldment	1
33	90001221	1/2 NC x 1 Hex Bolt	4
	20021537	Linkage Assembly (Ref. 2,3,4,5,7,8,9,10 and 11)	1
	20021539	Tree Assembly (Ref. 12,13,14,15,32,33)	1

HARDWARE

NUTS

90006194	3/16 NC Hex Nut
90006001	1/4 NC Hex Nut
90006003	5/16 NC Hex Nut
90006005	3/8 NC Hex Nut
90006007	7/16 NC Hex Nut
90006009	1/2 NC Hex Nut
90006010	1/2 NF Hex Nut
90006011	9/16 NC Hex Nut
90006013	5/8 NC Hex Nut
90006015	3/4 NC Hex Nut
90006017	7/8 NC Hex Nut
90006019	1 NC Hex Nut
90006023	1-1/4 NC Hex Nut
90006025	1-3/8 NC Hex Nut
90006027	1-1/2 NC Hex Nut
90006056	5/8 NF Slotted Hex Nut
90006058	3/4 NF Slotted Hex Nut
90006060	7/8 NF Slotted Hex Nut
90006062	1 NF Slotted Hex Nut
90006065	1-1/4 NC Slotted Hex Nut
90006066	1-1/4 NF Slotted Hex Nut
90006070	1-1/2 NF Slotted Hex Nut
90006135	1/4 NC Flanged Whiz Locknut
90006137	5/16 NC Flanged Whiz Locknut
90006139	3/8 NC Flanged Whiz Locknut
90006141	7/16 NC Flanged Whiz Locknut
90006143	1/2 NC Flanged Whiz Locknut
90006145	5/8 NC Flanged Whiz Locknut
90006270	3/8 NC Jam Nut
90006276	1/2 NC Jam Nut
90006280	5/8 NC Jam Nut
90006282	3/4 NC Jam Nut
90006284	7/8 NC Jam Nut
90006286	1 NC Jam Nut
90006288	1-1/8 NC Jam Nut
90006292	1-3/8 NC Jam Nut
90006496	1/4 NC Top Locknut
90006498	5/16 NC Top Locknut
90006500	3/8 NC Top Locknut
90006502	7/16 NC Top Locknut
90006504	1/2 NC Top Locknut
90006508	5/8 NC Top Locknut
90006510	3/4 NC Top Locknut
90006512	7/8 NC Top Locknut
90006514	1 NC Top Locknut
90006518	1-1/4 NC Top Locknut

WASHERS

90011007	3/16 Lockwasher
90011009	1/4 Lockwasher
90011010	5/16 Lockwasher
90011011	3/8 Lockwasher
90011012	7/16 Lockwasher
90011013	1/2 Lockwasher
90011014	9/16 Lockwasher
90011015	5/8 Lockwasher
90011017	3/4 Lockwasher
90011019	7/8 Lockwasher
90011021	1 Lockwasher
90011023	1-1/8 Lockwasher
90011025	1-1/4 Lockwasher
90011029	1-1/2 Lockwasher
90011030	3/16 Flat Washer
90011031	1/4 Flat Washer
90011032	5/16 Flat Washer
90011033	3/8 Flat Washer
90011034	7/16 Flat Washer
90011035	1/2 Flat Washer
90011036	9/16 Flat Washer
90011037	5/8 Flat Washer
90011038	3/4 Flat Washer
90011039	7/8 Flat Washer
90011040	1 Flat Washer
90011041	1-1/8 Flat Washer
90011042	1-1/4 Flat Washer
90011044	1-1/2 Flat Washer

INDEX

ASSEMBLY

- Dealer Set-Up Instructions, 26
- Delivery Check List (Dealer's Responsibility), 27
- Pre-Delivery Check List (Dealer's Responsibility), 26

GENERAL

- Abbreviations, 4
- Bolt Size Chart, 10
- Bolt Torque Chart, 11
- General Information, 4
- Introduction, ii
- Specifications, 1–3
 - 3-Point Hitch, 1
 - Model 2040, 2
 - Model 2065, 2
 - Model 2130, 3
 - Model 3030, 3
 - Tool Bar Codes, 1
- Table of Contents, 1
- Warranty, 122
- Warranty, Replacement Parts, 123

OPERATION

- Adjusting
 - Coulter, 21
 - Dual Discs, 22
 - Front Stabilizer Coulter, 21
 - Gang, 20
 - Leveling Toolbar Wings, 20
 - Rear Stabilizer, 22
 - Rear Trip Shank, 21
 - Slide Mount Tunnel Shields, 22
 - Support Wheels, 20
 - Sweep Adapter, 21
 - Sweeps, 22

OPERATION (Continued)

- Attaching & Removing Cultivator, 13
 - Attaching to Tractor with Quick Hitch, 13
 - Attaching to Tractor without Quick Hitch, 14
 - Electrical System, 17
 - Front Parking Stands, 17
 - Rear Parking Stands, 18
 - Removing from Tractor, 15
 - Rigid or Wing Cultivators in Operating Position (Wings Unfolded), 15
 - Wing Cultivators Equipped with Lift Assist Wheels, 16
 - Wing Cultivators in Transport Position (Wings Folded), 15
- Field Operation, 19
- Folding Cultivator, 18
- Lift Assist, 19
 - 3-Point Hitch Semi-Mounted Cultivator, 19
- Pre-Operation Check List (Owner's Responsibility), 13
- Storage, 20
- Transporting, 19
- Unfolding Cultivator, 18

PARTS,

- Index to Parts Lists, 65

SAFETY

- Check Lists
 - Delivery (Dealer's Responsibility), 27
 - Pre-Delivery (Dealer's Responsibility), 26
 - Pre-Operation (Owner's Responsibility), 13
- Safety Decals, 8
- Safety Rules, 5–7
- Safety Symbol (explanation), ii

SERVICE

- Greasing, 23
 - Storing Lubricants, 23
- Servicing Intervals, 24

WARRANTY

Please Enter Information Below and Save For Future Reference.

Date Purchased: _____ From (Dealer): _____

Model Number: _____ Serial Number: _____

ALLOWAY STANDARD, d/b/a ALLOWAY, warrants this product to be free from defect in material and workmanship for TWELVE (12) MONTHS COMMENCING ON THE DATE OF DELIVERY OF THE PRODUCT TO THE ORIGINAL PURCHASER.

Under no circumstances will this Warranty apply in the event that the product, in the good faith opinion of ALLOWAY, has been subjected to improper operation, improper maintenance, misuse, or an accident. This Warranty does not apply in the event that the product has been materially modified or repaired by someone other than ALLOWAY, a ALLOWAY authorized dealer or distributor, and/or a ALLOWAY authorized service center; This Warranty does not cover normal wear or tear, or normal maintenance items. This Warranty also does not cover repairs made with parts other than those obtainable through ALLOWAY.

This Warranty is extended solely to the original purchaser of the product. Should the original purchaser sell or otherwise transfer this product to a third party, this Warranty does not transfer to the third party purchaser in any way. There are no third party beneficiaries of this Warranty.

ALLOWAY makes no warranty, express or implied, with respect to tires or other parts or accessories not manufactured by ALLOWAY. Their respective manufacturers, if any, provide warranties for these items, separately. ALLOWAYS' obligation under this Warranty is limited to, at ALLOWAYS' option, the repair or replacement, free of charge, of the product if ALLOWAY, in its sole discretion, deems it to be defective or in noncompliance with this Warranty. The product must be returned to ALLOWAY with proof of purchase within thirty (30) days after such defect or noncompliance is discovered or should have been discovered, routed through the dealer and distributor from whom the purchase was made, transportation charges prepaid. ALLOWAY shall complete such repair or replacement within a reasonable time after ALLOWAY receives the product. THERE ARE NO OTHER REMEDIES UNDER THIS WARRANTY. THE REMEDY OF REPAIR OR REPLACEMENT IS THE SOLE AND EXCLUSIVE REMEDY UNDER THIS WARRANTY.

THERE ARE NO WARRANTIES, WHICH EXTEND BEYOND THE DESCRIPTION ON THE FACE OF THIS WARRANTY. ALLOWAY MAKES NO OTHER WARRANTY, EXPRESS OR IMPLIED, AND ALLOWAY SPECIFICALLY DISCLAIMS ANY IMPLIED WARRANTY OF MERCHANTABILITY AND/OR ANY IMPLIED WARRANTY OF FITNESS FOR A PARTICULAR PURPOSE.

ALLOWAY shall not be liable for any incidental or consequential losses, damages or expenses, arising directly or indirectly from the product, whether such claim is based upon breach of contract, breach of warranty, negligence, strict liability in tort or any other legal theory. Without limiting the generality of the foregoing. Alloway specifically disclaims any damages relating to (i) lost profits, business, revenues or goodwill; (ii) loss of crops; (iii) loss because of delay in harvesting; (iv) any expense or loss Incurred for labor, supplies, substitute machinery or rental; or (v) any other type of damage to property or economic loss.

This Warranty is subject to any existing conditions of supply, which may directly affect ALLOWAYS' ability to obtain materials or manufacture replacement parts.

No agent, representative, dealer, distributor, serviceperson, salesperson, or employee of any company; including without limitation, ALLOWAY, its authorized dealers, distributors, and service centers, is authorized to alter, modify, or enlarge this Warranty.

This Warranty is effective only if the warranty registration card is returned within ten (10) days.

Answers to any questions regarding warranty service and locations may be obtained by contacting:

Alloway
4230 14th Ave. NW
Fargo, North Dakota 58102
701-356-4983

WARRANTY

ALLOWAY STANDARD, d/b/a ALLOWAY, warrants this product to be free from defect in material and workmanship for a period of ninety (90) days from the date of delivery of the product to the original purchaser.

Under no circumstances will this Warranty apply in the event that the product, in the good faith opinion of ALLOWAY, has been subjected to improper operation, improper maintenance, misuse, or an accident. This Warranty does not cover normal wear or tear, or normal maintenance items.

This Warranty is extended solely to the original purchaser of the product. Should the original purchaser sell or otherwise transfer this product to a third party, this Warranty does not transfer to the third party purchaser in any way. There are no third party beneficiaries of this Warranty.

ALLOWAYS' obligation under this Warranty is limited to, at ALLOWAYS option, the repair or replacement, free of charge, of the product If ALLOWAY, in its sole discretion, deems it, to be defective or in noncompliance with this Warranty. The product must be returned to ALLOWAY with proof of purchase within thirty (30) days after such defect or noncompliance is discovered or should have been discovered, routed through the dealer and distributor from whom the purchase was made, transportation charges prepaid. ALLOWAY shall complete such repair or replacement within a reasonable time after ALLOWAY receives the product. THERE ARE NO OTHER REMEDIES UNDER THIS WARRANTY. THE REMEDY OF REPAIR OR REPLACEMENT IS THE SOLE AND EXCLUSIVE REMEDY UNDER THIS WARRANTY.

THERE ARE NO WARRANTIES WHICH EXTEND BEYOND THE DESCRIPTION ON THE FACE OF THIS WARRANTY. ALLOWAY MAKES NO OTHER WARRANTY, EXPRESS OR IMPLIED, AND ALLOWAY SPECIFICALLY DISCLAIMS ANY IMPLIED WARRANTY OF MERCHANTABILITY AND/OR ANY IMPLIED WARRANTY OF FITNESS FOR A PARTICULAR PURPOSE.

ALLOWAY shall not be liable for any incidental or consequential losses, damages or expenses, arising directly or indirectly from the product, whether such claim is based upon breach of contract, breach, of warranty, negligence, strict liability in tort or any other legal theory. Without limiting the generality of the foregoing, Alloway specifically disclaims any damages relating to (i) lost profits, business, revenues or goodwill; (ii) loss of crops; (iii) loss because of delay in harvesting; (iv) any expense or loss incurred for labor, supplies, substitute machinery or rental; or (v) any other type of damage to property or economic loss.

This Warranty is subject to any existing conditions of supply, which may directly affect ALLOWAYS' ability to obtain materials or manufacture replacement parts.

No agent, representative, dealer, distributor, service person, salesperson, or employee of any company, including without limitation, ALLOWAY, Its authorized dealers, distributors, and service centers, IS authorized to alter, modify, or enlarge this Warranty.

Answers to any questions regarding warranty service and locations may be obtained by contacting:

Alloway
4230 14th Ave. NW
Fargo, North Dakota 58102
701-356-4983





PART NO.

20032546

Alloway
4230 14th Ave. NW
Fargo, North Dakota 58102
701-356-4983

REVISED 12/03

