

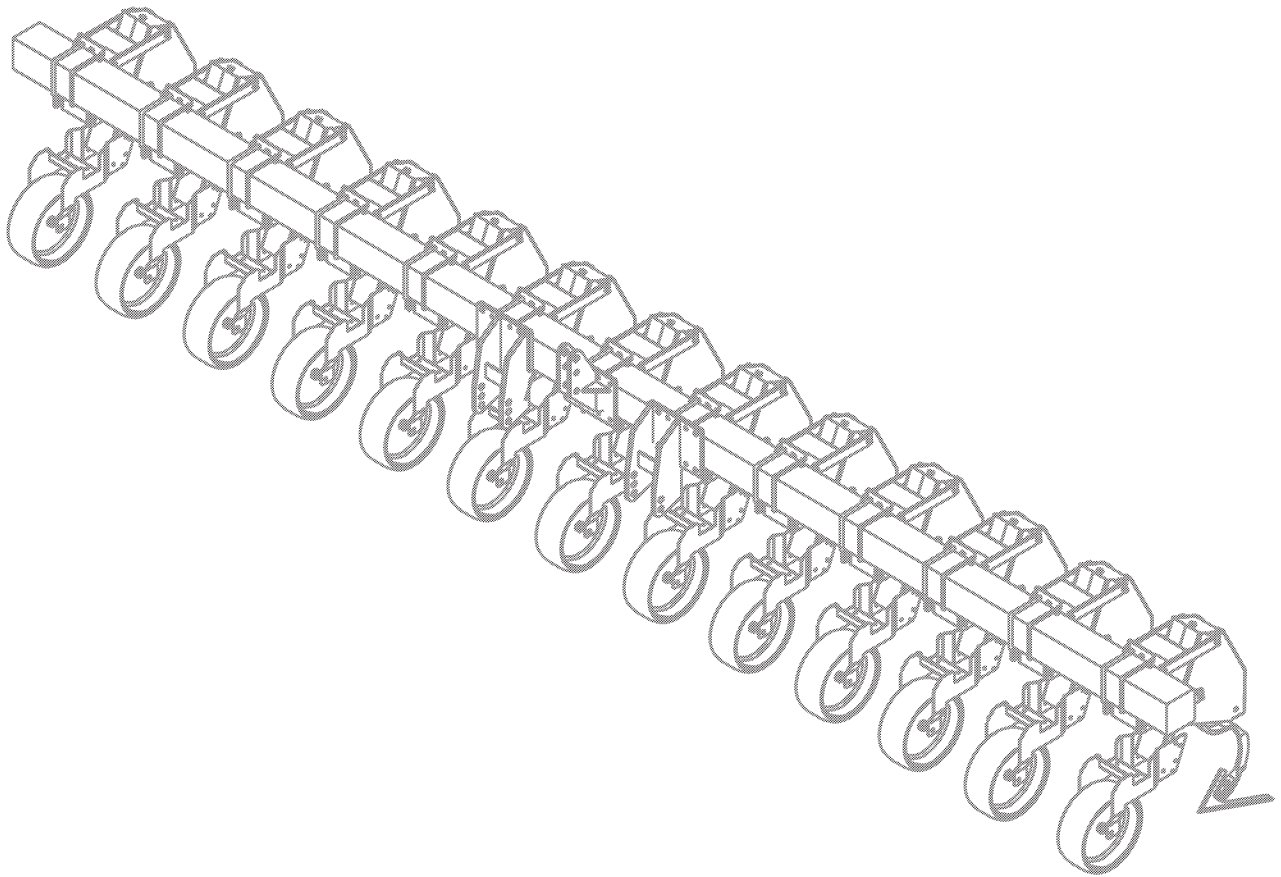

ROW CROP CULTIVATOR MODEL 3130



OPERATOR'S MANUAL

PN-20033738 (Rev. 4/08)



TO THE DEALER:

Assembly and proper installation of this product is the responsibility of the Alloway dealer. Read manual instructions and safety rules. Make sure all items on the Dealer's Pre-Delivery and Delivery Check Lists in the Operator's Manual are completed before releasing equipment to the owner.

The dealer must complete the Warranty Registration included in this manual. Both dealer and customer must sign the registration which certifies that all Dealer Check List items have been completed. The dealer is to return the prepaid postage portion to Alloway, give one copy to the customer, and retain one copy. **Note: Warranty credit is subject to this form being completed and returned.**

TO THE OWNER:

Read this manual before operating your Alloway equipment. The information presented will prepare you to do a better and safer job. Keep this manual handy for ready reference. Require all operators to read this manual carefully and become acquainted with all the adjustment and operating procedures before attempting to operate. Replacement manuals can be obtained from your dealer or, in the United States and Canada, by calling 1-877-275-8714.

The equipment you have purchased has been carefully engineered and manufactured to provide dependable and satisfactory use. Like all mechanical products, it will require cleaning and upkeep. Lubricate the unit as specified. Observe all safety information in this manual and safety decals on the equipment.

For service, your authorized Alloway dealer has trained mechanics, genuine Alloway service parts, and the necessary tools and equipment to handle all your needs.

Use only genuine Alloway service parts. Substitute parts will void the warranty and may not meet standards required for safe and satisfactory operation. Record the model number and serial number of your equipment in the spaces provided:

Model: _____ **Date of Purchase:** _____

Serial Number: (see Safety Decal section for location) _____

Provide this information to your dealer to obtain correct repair parts.

Throughout this manual, the term **IMPORTANT** is used to indicate that failure to observe can cause damage to equipment. The terms **CAUTION**, **WARNING** and **DANGER** are used in conjunction with the Safety-Alert Symbol, (a triangle with an exclamation mark), to indicate the degree of hazard for items of personal safety.



This Safety-Alert Symbol indicates a hazard and means **ATTENTION! BECOME ALERT! YOUR SAFETY IS INVOLVED!**



Indicates an imminently hazardous situation that, if not avoided, will result in death or serious injury.



Indicates a potentially hazardous situation that, if not avoided, could result in death or serious injury, and includes hazards that are exposed when guards are removed.



Indicates a potentially hazardous situation that, if not avoided, may result in minor or moderate injury.

IMPORTANT

Indicates that failure to observe can cause damage to equipment.

NOTE

Indicates helpful information.

STANDARD
alloway

TABLE OF CONTENTS

INTRODUCTION	ii
GENERAL INFORMATION	1
SPECIFICATIONS	2
SAFETY RULES	3-5
SAFETY DECALS	7-9
OPERATION	10
SERVICE	30
ASSEMBLY	33
INDEX TO PARTS LISTS	65
BOLT TORQUE CHART	94
BOLT SIZE CHART & ABBREVIATIONS	95
INDEX	96
PRODUCT WARRANTY	INSIDE BACK COVER
REPLACEMENT PARTS WARRANTY	BACK COVER

GENERAL INFORMATION

The purpose of this manual is to assist you in operating and maintaining your row crop cultivator. Read it carefully. It furnishes information and instructions that will help you achieve years of dependable performance. These instructions have been compiled from extensive field experience and engineering data. Some information may be general in nature due to unknown and varying operating conditions. However, through experience and these instructions, you should be able to develop procedures suitable to your particular situation.

The illustrations and data used in this manual were current at the time of printing but, due to possible inline production changes, your machine may vary slightly in detail. We reserve the right to redesign and change the machines as may be necessary without notification.

Throughout this manual, references are made to right and left direction. These are determined by standing behind the equipment facing the direction of forward travel.

SPECIFICATIONS

The Alloway Row Crop Cultivator has several toolbar types and a variety of optional equipment for row crop applications. Optional equipment may change these specifications. Cultivator weights do not include optional equipment.

3-POINT HITCHES

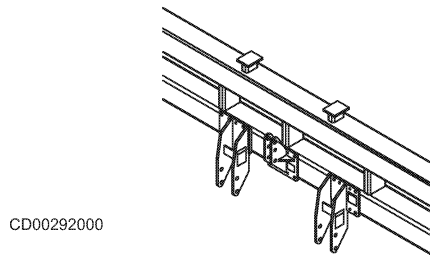

TYPE "D"

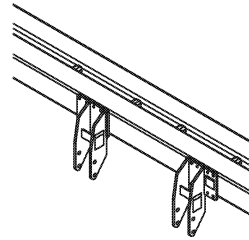

TYPE "E" (USE WITH LIFT ASSIST)

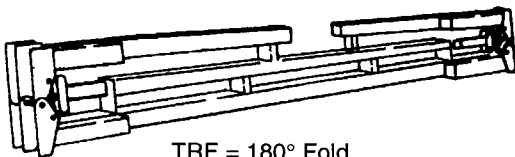

TRF = 180° Fold
Reinforced Hinges

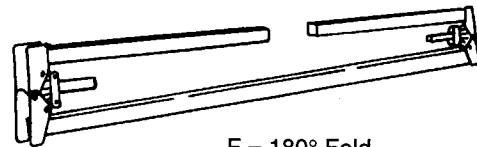

F = 180° Fold



TRR = Rigid

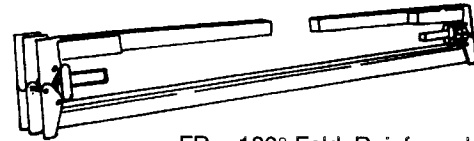

FR = 180° Fold Reinforced
Double Bar

MODEL 3130 SPRING TINE SHANK CULTIVATORS

Size	Toolbar	3-Pt. Hitch	Trans. Width	Weight
6 Row 22"	R	D	152"	1955 lbs.
6 Row 30"	R	D	200"	2215 lbs.
8 Row 22"	R	D	200"	2475 lbs.
8 Row 30"	R	D	252"	2875 lbs.
8 Row 30"	F	D	145"	3305 lbs.
12 Row 22"	R	D	288"	3505 lbs.
12 Row 22"	F	D	157"	4000 lbs.
12 row 24"	TRR	D	300"	3530 lbs.
12 Row 24"	F	D	171"	4010 lbs.
12 Row 30"	TRF	D	213"	5175 lbs.
16 Row 30"	TRF	D	267"	6220 lbs.
18 Row 22"	TRF	D	246"	6405 lbs.
24 Row 22"	FR	E	288"	8375 lbs.

Weights are without optional equipment.

**MODEL 3130
RIGID SHANK CULTIVATORS**

Size	Toolbar	3-Pt. Hitch	Trans. Width	Weight
6 Row 30"	R	D	200"	2215 lbs.
6 Row 36/40"	R	D	252"	2475 lbs.
8 Row 30"	R	D	252"	2875 lbs.
8 Row 30"	F	D	145"	3305 lbs.
8 Row 40"	TRR	D	328"	3305 lbs.
8 Row 36"	TRF	D	200"	4000 lbs.
12 Row 30"	TRF	D	213"	5175 lbs.
16 row 30"	TRF	D	267"	6220 lbs.
12 Row 38"	TRF	D	267"	6000 lbs.
8 Row 40"	TRF	D	210"	5000 lbs.

Weights are without optional equipment.

OPTIONAL EQUIPMENT

Description	Part No.	Weight
Guide & Support Wheels		
Adjustable guide wheel	20013666	312 lbs./pair
Semi-pneumatic guide wheels	20013699	175 lbs./pair
Steel guide wheels	20013668	220 lbs./pair
King guide strut	20013639	777 lbs./pair
Shields		
24" Rolling shields	20013636	57 lbs./row
24" Rolling end shield	20013637	84 lbs./pair
Open top shields 22" row	20013691	102 lbs./row
Open top shields 30" row	20013642	104 lbs./row
Open top shields 36-40" row	20013692	105 lbs./row
Flip-up 14" disc with knife mounts and knives	20013645	78 lbs./row
Row Weeder Attachment		
Row weeder disc with clamp	20013655	115 lbs./row

SAFETY RULES



ATTENTION! BECOME ALERT! YOUR SAFETY IS INVOLVED!



Safety is a primary concern in the design and manufacture of our products. Unfortunately, our efforts to provide safe equipment can be wiped out by an operator's single careless act.

In addition to the design and configuration of equipment, hazard control and accident prevention are dependent upon the awareness, concern, judgement, and proper training of personnel involved in the operation, transport, maintenance and storage of equipment.

It has been said "The best safety device is an informed, careful operator." We ask you to be that kind of operator.

TRAINING

- **Safety instructions are important! Read all attachment and power unit manuals; follow all safety rules and safety decal information. (Replacement manuals are available from dealer or, in the United States and Canada, call 1-877-275-8714.) Failure to follow instructions or safety rules can result in serious injury or death.**
- **If you do not understand any part of this manual and need assistance, see your dealer.**
- **Know your controls and how to stop engine and attachment quickly in an emergency.**
- **Operators must be instructed in and be capable of the safe operation of the equipment, its attachments, and all controls. Do not allow anyone to operate this equipment without proper instructions.**
- **Keep hands and body away from pressurized lines. Use paper or cardboard, not hands or other body parts to check for leaks. Wear safety goggles. Hydraulic fluid under pressure can easily penetrate skin and will cause serious injury or death.**
- **Make sure that all operating and service personnel know that if hydraulic fluid penetrates skin, it must be surgically removed as soon as possible by a doctor familiar with this form of injury or gangrene, serious injury, or death will result. CONTACT A PHYSICIAN IMMEDIATELY IF FLUID ENTERS SKIN OR EYES. DO NOT DELAY.**
- **Never allow children or untrained persons to operate equipment.**

PREPARATION

- **Check that all hardware is properly installed. Always tighten to torque chart specifications unless instructed otherwise in this manual.**
- **Air in hydraulic systems can cause erratic operation and allow loads or equipment components to drop unexpectedly. When connecting equipment or hoses or performing any hydraulic maintenance, purge any air in hydraulic system by operating all hydraulic functions several times. Do this before putting into service or allowing anyone to approach the equipment.**
- **Make sure all hydraulic hoses, fittings, and valves are in good condition and not leaking before starting power unit or using equipment. Check and route hoses carefully to prevent damage. Hoses must not be twisted, bent sharply, kinked, frayed, pinched, or come into contact with any moving parts. Operate moveable components through full operational range to check clearances. Replace any damaged hoses immediately.**
- **Always wear relatively tight and belted clothing to avoid entanglement in moving parts. Wear sturdy, rough-soled work shoes and protective equipment for eyes, hair, hands, hearing, and head.**
- **When attaching a pull-type unit to the tractor drawbar, always use a high-strength drawbar pin. The drawbar pin must have a device that will lock it into position.**
- **Make sure attachment is properly secured, adjusted, and in good operating condition.**
- **Power unit must be equipped with ROPS or ROPS cab and seat belt. Keep seat belt securely fastened. Falling off power unit can result in death from being run over or crushed. Keep foldable ROPS systems in "locked up" position at all times.**
- **Make sure all safety decals are installed. Replace if damaged. (See Safety Decals section for location.)**
- **A minimum 20% of tractor and equipment weight must be on the tractor front wheels when attachments are in transport position. Without this weight, tractor could tip over, causing personal injury or death. The weight may be attained with a loader, front wheel weights, ballast in tires or front tractor weights. Weigh the tractor and equipment. Do not estimate.**



SAFETY RULES

ATTENTION! BECOME ALERT! YOUR SAFETY IS INVOLVED!



OPERATION

- Do not allow bystanders in the area when operating, attaching, removing, assembling, or servicing equipment.
- Never walk, stand, or place yourself or others under a raised wing or in the path of a lowering wing. Hydraulic system leak-down, hydraulic system failures, mechanical failures, or movement of control levers can cause wings to drop unexpectedly and cause severe injury or death.
- Keep bystanders away from equipment.
- Do not operate equipment while under the influence of alcohol or drugs.
- Operate only in daylight or good artificial light.
- Keep hands, feet, hair, and clothing away from equipment while engine is running. Stay clear of all moving parts.
- Always comply with all state and local lighting and marking requirements.
- Never allow riders on power unit or attachment.
- Power unit must be equipped with ROPS or ROPS cab and seat belt. Keep seat belt securely fastened. Falling off power unit can result in death from being run over or crushed. Keep foldable ROPS systems in “locked up” position at all times.
- Always sit in tractor seat when operating controls or starting engine. Securely fasten seat belt, place transmission in neutral, engage brake, and ensure all other controls are disengaged before starting tractor engine.
- Look down and to the rear and make sure area is clear before operating in reverse.
- Do not operate on steep slopes.
- Do not stop, start, or change directions suddenly on slopes.
- Use extreme care and reduce ground speed on slopes and rough terrain.
- Watch for hidden hazards on the terrain during operation.
- Stop tractor and implement immediately upon striking an obstruction. Turn off engine, remove key, inspect, and repair any damage before resuming operation.
- **AVOID INJURY OR DEATH FROM POWER LINES:**
 - Stay away from power lines.
 - Electrocutation can occur without direct con-

tact.

- Check clearances before raising implement.
- Do not leave the operator's seat if any part of the tractor or implement contacts electric lines.
- Before folding or unfolding cultivator:
 - Make sure you have adequate clearance on each side and overhead.
 - Make sure wing cylinder restrictor fittings are properly installed.
 - Make sure wing-mounted gauge wheels and guide coulters will not contact tractor cab or tires.
- Implement can tip over and crush if attached, removed, or stored improperly.
 - Read and follow instructions and safety rules for procedures and use of parking stands.
 - Front parking stands must be on all cultivators.
 - Rear parking stands must be on all folding cultivators unless cultivator has rear lift assist.
 - Parking stands must be kept in good condition and replaced if damaged.
 - Remove on solid, level ground.
 - Before removing from tractor, cultivator must be level and stable with parking stands properly positioned and rear lift assist (when equipped) lowered to rest on cylinder stops.
 - Keep all bystanders away.
- Before dismounting power unit or performing any service or maintenance, follow these steps: disengage power to implement, lower the 3-point hitch and all raised components to the ground, operate valve levers to release any hydraulic pressure, set parking brake, stop engine, remove key, and unfasten seat belt.
- **NEVER GO UNDERNEATH EQUIPMENT.** Never place any part of the body underneath equipment or between moveable parts even when the engine has been turned off. Hydraulic system leak down, hydraulic system failures, mechanical failures, or movement of control levers can cause equipment to drop or rotate unexpectedly and cause severe injury or death.
 - Service work does not require going underneath.
 - Read Operator's Manual for service instructions or have service performed by a qualified dealer.

(Safety Rules continued on next page)

SAFETY RULES



ATTENTION! BECOME ALERT! YOUR SAFETY IS INVOLVED!



(Safety Rules continued from previous page)

- Before servicing, unfold completely to operating position. Do not service with wings in any other position.

MAINTENANCE

- Before dismounting power unit or performing any service or maintenance, follow these steps: disengage power to implement, lower the 3-point hitch and all raised components to the ground, operate valve levers to release any hydraulic pressure, set parking brake, stop engine, remove key, and unfasten seat belt.

- Before servicing, unfold completely to operating position. Do not service with wings in any other position.

- **NEVER GO UNDERNEATH EQUIPMENT.** Never place any part of the body underneath equipment or between moveable parts even when the engine has been turned off. Hydraulic system leak down, hydraulic system failures, mechanical failures, or movement of control levers can cause equipment to drop or rotate unexpectedly and cause severe injury or death.

- Service work does not require going underneath.
- Read Operator's Manual for service instructions or have service performed by a qualified dealer.

- Do not modify or alter or permit anyone else to modify or alter the equipment or any of its components in any way.

- Your dealer can supply original equipment hydraulic accessories and repair parts. Substitute parts may not meet original equipment specifications and may be dangerous.

- Always wear relatively tight and belted clothing to avoid entanglement in moving parts. Wear sturdy, rough-soled work shoes and protective equipment for eyes, hair, hands, hearing, and head.

- Do not allow bystanders in the area when operating, attaching, removing, assembling, or servicing equipment.

- Make sure attachment is properly secured, adjusted, and in good operating condition.

- Make sure hydraulic hoses and cylinders are fully purged of air before putting into service. Keep all persons away. Fill the system by raising and lowering all functions several times. Air in the system can allow components to fall unexpectedly.

- Keep all persons away from operator control area while performing adjustments, service, or maintenance.

- Do not handle blades with bare hands. Careless or improper handling may result in serious injury.

- Tighten all bolts, nuts and screws to torque chart specifications. Check that all cotter pins are installed securely to ensure equipment is in a safe condition before putting unit into service.

- Make sure all safety decals are installed. Replace if damaged. (See Safety Decals section for location.)

- Do not disconnect hydraulic lines until machine is securely blocked or placed in lowest position and system pressure is released by operating valve levers.

STORAGE

- Block equipment securely for storage.

- Keep children and bystanders away from storage area.





SAFETY & INSTRUCTIONAL DECALS

ATTENTION! BECOME ALERT! YOUR SAFETY IS INVOLVED!
Replace Immediately If Damaged!



TYPE TRR RIGID BAR

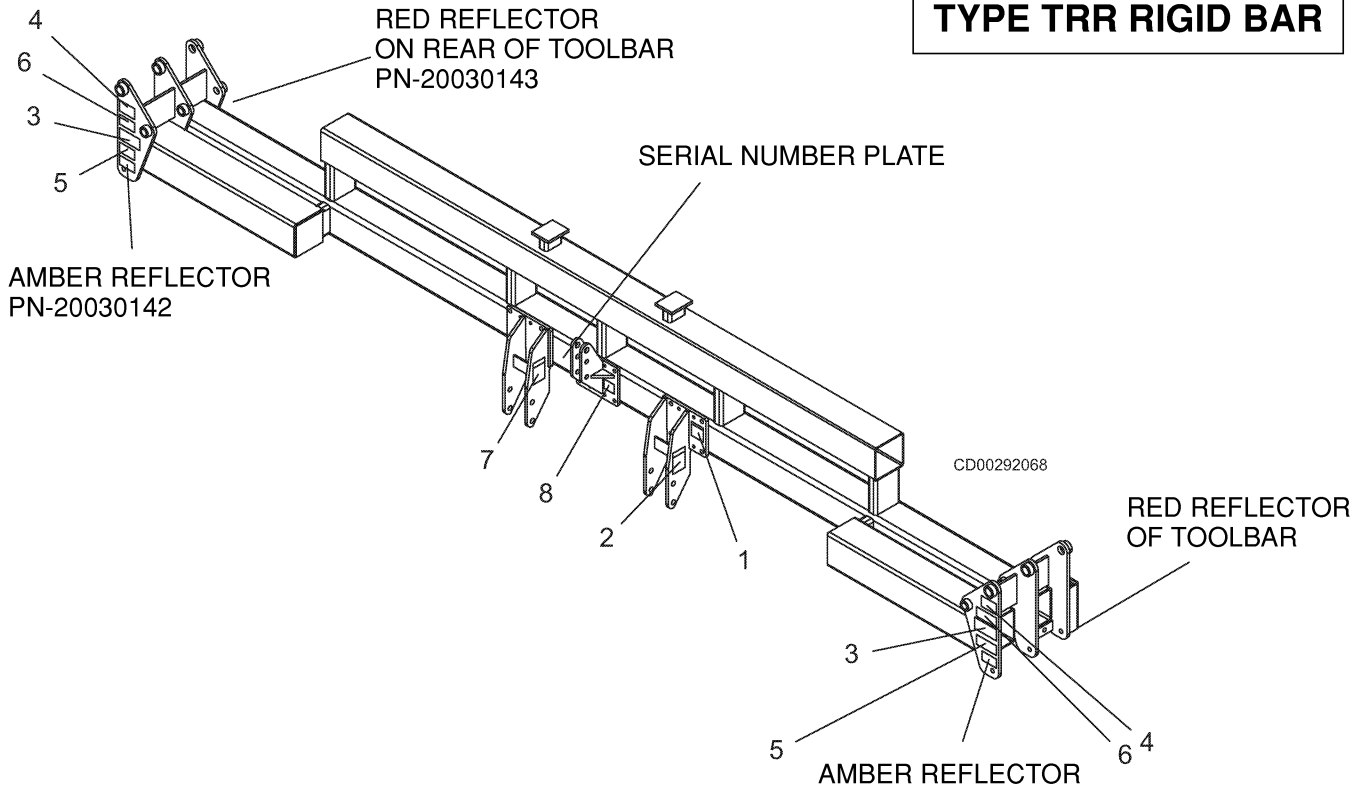

TYPE F & TRF FOLDING BARS

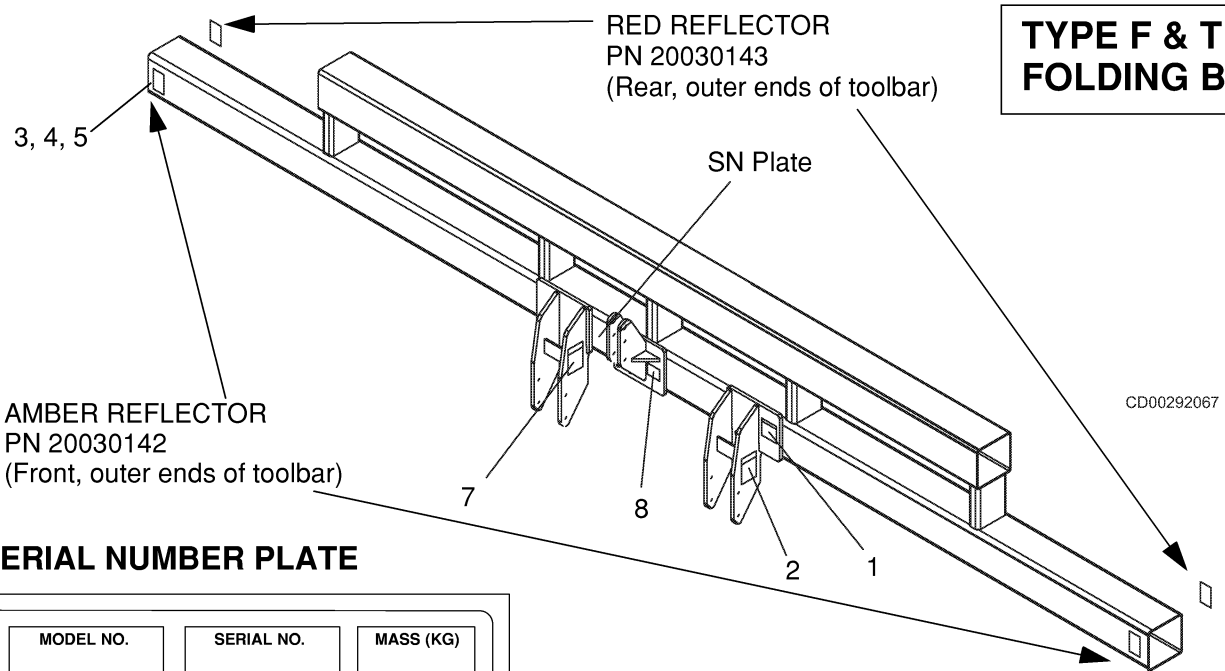

SERIAL NUMBER PLATE

MODEL NO.	SERIAL NO.	MASS (KG)
ID NO.		YR OF MFG.

(Safety Decals continued on next page)

SAFETY & INSTRUCTIONAL DECALS



ATTENTION! BECOME ALERT! YOUR SAFETY IS INVOLVED!
Replace Immediately If Damaged!



(Safety Decals continued from previous page)

7 - PN 20033891

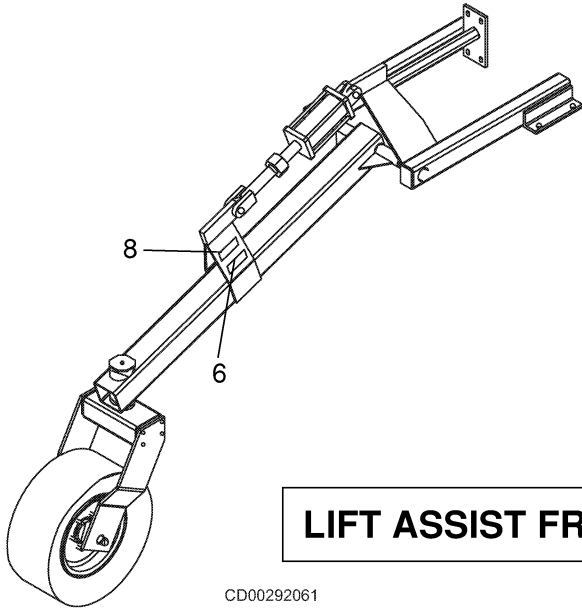

LIFT ASSIST FRAME

CD00292061

WARNING

IMPLEMENT CAN TIP OVER AND CRUSH IF ATTACHED, REMOVED OR STORED IMPROPERLY.

- Read and follow Operator's Manual instructions and safety rules for procedures and use of parking stands.
- Front parking stands must be on all cultivators.
- Rear parking stands must be on all folding cultivators unless cultivator has rear lift assist.
- Parking stands must be kept in good condition or replaced if damaged.
- Remove on solid, level ground.
- Cultivator must be level and stable with parking stands properly positioned and rear lift assist (when equipped) lowered to rest on cylinder stops before removing from tractor.
- Keep all bystanders away.

Failure to follow these instructions can result in serious injury or death.

20033891

1 - PN 20033911

WARNING

TO AVOID SERIOUS INJURY OR DEATH:

- Read Operator's Manual before operating, servicing or repairing equipment. Follow all safety rules and instructions. (Manuals are available from dealer or, in the United States and Canada, call 1-877-275-8714.)
- Operate from tractor seat only.
- Lower equipment to ground, stop engine, remove key and set brake before dismantling tractor.
- Allow no children or untrained persons to operate equipment.

FAILURE TO FOLLOW THESE INSTRUCTIONS CAN RESULT IN INJURY OR DEATH.

2- PN 20033887

WARNING



FALLING OFF CAN RESULT IN BEING RUN OVER.

- Tractor must be equipped with ROPS (or ROPS CAB) and seat belt. Keep foldable ROPS systems in "locked up" position at all times.
- Buckle Up! Keep seat belt securely fastened.
- Allow no riders.

RAISED IMPLEMENT CAN DROP AND CRUSH.

- Never go underneath raised implement which can drop from equipment or tractor 3-point hitch hydraulic leak down, hydraulic system failures, movement of control levers or mechanical linkage failures.
- Service work does not require going underneath implement. Read manual instructions.

FALLING OFF OR GOING UNDERNEATH IMPLEMENT CAN RESULT IN SERIOUS INJURY OR DEATH.

20033887

3 - PN 20033890

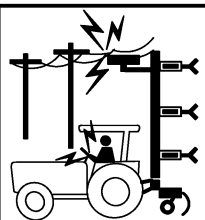

DANGER

To avoid injury or death, do not contact electric lines.

20033890

SAFETY & INSTRUCTIONAL DECALS
ATTENTION! BECOME ALERT! YOUR SAFETY IS INVOLVED!
Replace Immediately If Damaged!

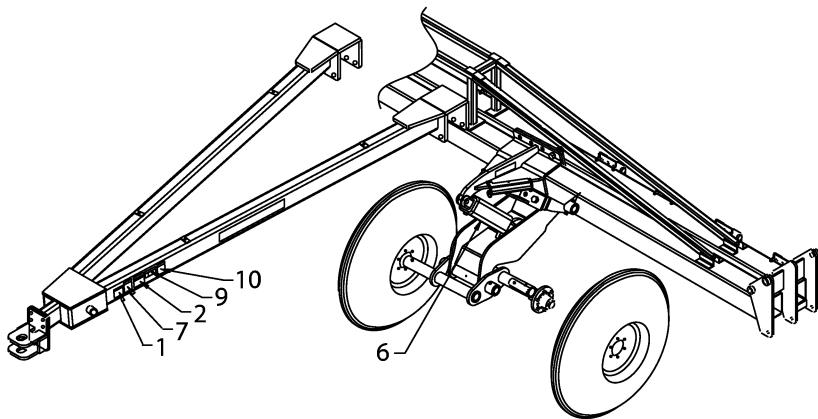

4 - PN 20033889

⚠ WARNING
Air in hydraulic systems can allow wings or other components to fall rapidly when being raised or lowered. Before operating or allowing anyone to approach the equipment, purge all air from the system by operating all hydraulic functions several times.
20033889

8 - PN 20033893

IMPORTANT
Do not use upper 3-point top link when cultivator is equipped with rear lift assist. Damage will occur to equipment.
20033893

6 - PN 50630195

<p>19924-B</p>	⚠ WARNING
	<p>Check for leaks with cardboard; never use hand. Before loosening fittings: lower load, release pressure, and be sure oil is cool. Consult physician immediately if skin penetration occurs.</p>

5 - PN 20033888

	⚠ WARNING
	<p>To avoid injury or death, stand clear of machine when wings are being folded or unfolded. Mechanical failure, hydraulic system failure, or air in hydraulic system can allow wings to fall rapidly.</p> <p align="right">20033888</p>

10 - PN 20034030

⚠ WARNING	
RAISED EQUIPMENT CAN-DROP AND CRUSH	<p align="center">CYLINDER LOCKS</p> <p align="right">20034030</p>
<p>Install locks before transporting or working underneath raised implement. Locks must be installed correctly, kept in good condition, and stored on implement. Read and follow manual instructions. FAILURE TO FOLLOW INSTRUCTIONS CAN RESULT IN SERIOUS INJURY OR DEATH.</p>	

9 - PN 20034028

⚠ WARNING		⚠ ADVERTENCIA
<p>TIPPING HAZARD Weight of attachments on rear can cause hitch to raise rapidly during unhitching. SUPPORT TOOLBAR AND TONGUE ON PARKING STANDS BEFORE LOWERING UNIT.</p>		<p>PELIGRO DE VOLCADURA El peso de los accesorios en la parte trasera puede provocar que el mecanismo de enganche suba con rapidez durante el desenganche. APOYE LA BARRA Y LA LENGÜETA SOBRE SOPORTES ANTES DE BAJAR LA UNIDAD.</p> <p align="right">20034028</p>

NOTES

OPERATION

Safety is a primary concern in the design and manufacture of our products. Unfortunately, our efforts to provide safe equipment can be wiped out by an operator's single careless act.

In addition to the design and configuration of equipment, hazard control and accident prevention are dependent upon the awareness, concern, judgement, and proper training of personnel involved in the operation, transport, maintenance and storage of equipment.

It has been said "The best safety device is an informed, careful operator." We ask you to be that kind of operator.

WARNING

■ **Safety instructions are important! Read all attachment and power unit manuals; follow all safety rules and safety decal information. (Replacement manuals are available from dealer or, in the United States and Canada, call 1-877-275-8714.) Failure to follow instructions or safety rules can result in serious injury or death.**

■ **Know your controls and how to stop engine and attachment quickly in an emergency.**

■ **Make sure that all operating and service personnel know that if hydraulic fluid penetrates skin, it must be surgically removed as soon as possible by a doctor familiar with this form of injury or gangrene, serious injury, or death will result. CONTACT A PHYSICIAN IMMEDIATELY IF FLUID ENTERS SKIN OR EYES. DO NOT DELAY.**

■ **Never allow children or untrained persons to operate equipment.**

■ **Keep bystanders away from equipment.**

■ **A minimum 20% of tractor and equipment weight must be on the tractor front wheels when attachments are in transport position. Without this weight, tractor could tip over, causing personal injury or death. The weight may be attained with a loader, front wheel weights, ballast in tires or front tractor weights. Weigh the tractor and equipment. Do not estimate.**

WARNING

■ **Before dismounting power unit or performing any service or maintenance, follow these steps: disengage power to implement, lower the 3-point hitch and all raised components to the ground, operate valve levers to release any hydraulic pressure, set parking brake, stop engine, remove key, and unfasten seat belt.**

■ **Implement can tip over and crush if attached, removed, or stored improperly.**

- **Read and follow instructions and safety rules for procedures and use of parking stands.**
- **Front parking stands must be on all cultivators.**
- **Rear parking stands must be on all folding cultivators unless cultivator has rear lift assist.**
- **Parking stands must be kept in good condition and replaced if damaged.**
- **Remove on solid, level ground.**
- **Before removing from tractor, cultivator must be level and stable with parking stands properly positioned and rear lift assist (when equipped) lowered to rest on cylinder stops.**
- **Keep all bystanders away.**

■ **NEVER GO UNDERNEATH EQUIPMENT. Never place any part of the body underneath equipment or between moveable parts even when the engine has been turned off. Hydraulic system leak down, hydraulic system failures, mechanical failures, or movement of control levers can cause equipment to drop or rotate unexpectedly and cause severe injury or death.**

- **Service work does not require going underneath.**
- **Read Operator's Manual for service instructions or have service performed by a qualified dealer.**

■ **Before folding or unfolding cultivator:**

- **Make sure you have adequate clearance on each side and overhead.**
- **Make sure wing cylinder restrictor fittings are properly installed.**
- **Make sure wing-mounted gauge wheels and guide coulters will not contact tractor cab or tires.**

CAUTION

- Always wear relatively tight and belted clothing to avoid entanglement in moving parts. Wear sturdy, rough-soled work shoes and protective equipment for eyes, hair, hands, hearing, and head.
- Always sit in tractor seat when operating controls or starting engine. Securely fasten seat belt, place transmission in neutral, engage brake, and ensure all other controls are disengaged before starting tractor engine.
- Always comply with all state and local lighting and marking requirements.

DANGER

- AVOID INJURY OR DEATH FROM POWER LINES:
 - Stay away from power lines.
 - Electrocutation can occur without direct contact.
 - Check clearances before raising implement.
 - Do not leave the operator's seat if any part of the tractor or implement contacts electric lines.

PRE-OPERATION CHECK LIST (OWNER'S RESPONSIBILITY)

IMPORTANT

■ This Pre-Operation Check List is provided for the operator. It is important to follow for both personal safety and maintenance of the row crop cultivator.

- ___ Review and follow all safety rules and safety decal instructions on page 4 through page 9.
- ___ Check that all safety decals are installed and in good condition. Replace if damaged.
- ___ Check that all hardware and cotter pins are properly installed and secured.
- ___ Check that equipment is properly and securely attached to tractor.
- ___ Check all lubrication points and grease as instructed in "Service, lubrication information."
- ___ Check hydraulic reservoir level.
- ___ Check that all hydraulic hoses and fittings are in good condition and not leaking before starting tractor. Check that hoses are not twisted, bent sharply, kinked, frayed or pulled tight. Replace any damaged hoses immediately.
- ___ Raise and lower equipment and wings to make sure air is purged from hydraulic cylinder and hose.
- ___ Make sure tractor 3-point lift links do not interfere with hydraulic hoses.
- ___ Make sure tractor ROPS or ROPS cab and seat belt are in good condition. Keep seat belt securely fastened during operation.
- ___ Before starting engine, operator must be in tractor seat with seat belt fastened. Place transmission in neutral or park, engage brake and disengage tractor PTO.

Attaching Cultivator (Pull-Type Hitch)

1. Park cultivator on a solid, level, dry area that is free from debris and other foreign objects.

NOTE: Before attaching cultivator, be sure the tractor has a clevis type hitch that can handle drawbar loads in both the downward and upward direction. Be sure to use a hardened drawbar pin that allows for a mechanical retainer, such as a klik pin.

2. Clear the area of bystanders, especially children.

 **WARNING**

■ **Keep bystanders away from equipment.**

3. Set cultivator hitch height to match tractor drawbar height.

4. Carefully back up the tractor to align with hitch.

5. Pin cultivator to tractor drawbar, using hardened drawbar pin. Attach a mechanical retainer, such as a klik pin.

6. Attach safety chain to tractor.

7. Clean the hydraulic couplers and fittings to avoid oil contamination.

 **WARNING**

■ **Air in hydraulic systems can cause erratic operation and allow loads or equipment components to drop unexpectedly. When connecting equipment or hoses or performing any hydraulic maintenance, purge any air in hydraulic system by operating all hydraulic functions several times. Do this before putting into service or allowing anyone to approach the equipment.**

8. Connect wing fold hydraulic lines to the tractor #1 hydraulic couplers. Couplers must be connected so that pushing the control lever forward moves (unfolds) the wings to operating position and pulling the lever rearward moves (folds) the wings to transport position.

9. Connect lift wheel hydraulic lines to the tractor #2 hydraulic couplers. Couplers must be connected so that pushing the control lever forward lowers the cultivator and pulling the lever rearward raises the cultivator.

10. Connect 7-pin electrical connector to the tractor.

11. Raise the tool bar slightly so that rear parking stands are off the ground.

12. Stop engine, set parking brake, wait for all moving parts to stop. Remove the ignition key before dismounting.

13. Raise all parking stands to upper position. Install pin through parking stands and bracket.

IMPORTANT

■ **To prevent damage, raise parking stands to upper position before moving cultivator. parking stands must be replaced if bent or damaged.**

■ **To prevent damage to cultivator, do not drop. Lower slowly. Dropping cultivator could result in damage to gauge wheel.**

Operation *Cont'd*

Attaching Cultivator (Quick Hitch)

1. Park cultivator on a solid, level, dry area that is free from debris and other foreign objects.

NOTE: Before attaching tractor to cultivator, be sure hitch pins and spacers are completely assembled to match the hitch configuration of your tractor as shown in Figure 1.

2. Set the height of the 3-point hitch so that quick hitch coupler is lower than the mounting pins.

3. Make sure the lower links on the tractor are set in the free-float position (see tractor manual for details).

4. Make sure 3-point hitch is set in the sway position (see tractor manual for details).

5. Align the couplers under the mounting pins while backing up.

NOTE: Use the proper size bushings for lower link mounting pins and the correct upper link pin location for Category II, III, or III N operation.

6. Clear the area of bystanders, especially children.

WARNING

■ Keep bystanders away from equipment.

7. Carefully back up the tractor until the coupler hooks align with the cultivator hitch pins.

8. When the coupler is under the pins, slowly raise the 3-point hitch. Be sure each of the mounting pins seat in their respective coupler hook.

9. Stop engine, set parking brake, wait for all moving parts to stop. Remove the ignition key before dismounting.

10. Release the coupler retainer locks to secure the mounting pins in the coupler.

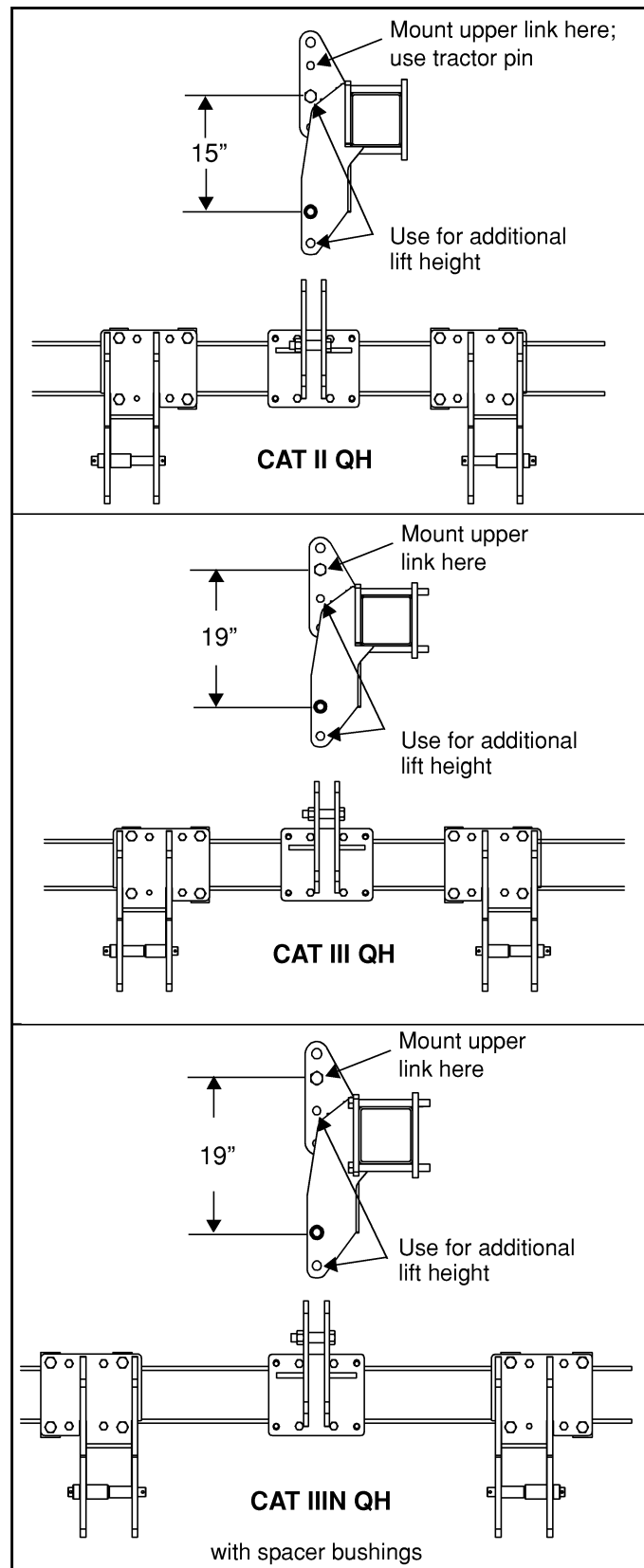

Figure 1 Quick Hitch Configurations

Attaching Cultivator (Quick Hitch) *Cont'd*

11. Clean the hydraulic couplers and fittings to avoid oil contamination.

 **WARNING**

■ **Air in hydraulic systems can cause erratic operation and allow loads or equipment components to drop unexpectedly. When connecting equipment or hoses or performing any hydraulic maintenance, purge any air in hydraulic system by operating all hydraulic functions several times. Do this before putting into service or allowing anyone to approach the equipment.**

12. Connect hydraulic couplings. Couplings must be completely engaged.

13. Connect wing fold hydraulic lines to the tractor #1 hydraulic couplers. Couplers must be connected so that pushing the control lever forward moves (unfolds) the wings to operating position and pulling the lever rearward moves (folds) the wings to transport position.

14. Connect lift assist hydraulic lines to the tractor #2 hydraulic couplers. Couplers must be connected so that pushing the control lever forward lowers the cultivator and pulling the lever rearward raises the cultivator.

15. Connect 7-pin electrical connector to the tractor.

16. Raise the tool bar slightly.

17. Stop engine, set parking brake, wait for all moving parts to stop. Remove the ignition key before dismounting.

18. Raise all parking stands to upper position. Install pin through parking stands and bracket.

IMPORTANT

■ **To prevent damage, raise parking stands to upper position before moving cultivator. parking stands must be replaced if bent or damaged.**

■ **To prevent damage to cultivator, do not drop. Lower slowly. Dropping cultivator could result in damage to gauge wheel.**

Operation *Cont'd*

Attaching Cultivator to Tractor (Standard Hitch)

1. Park cultivator on a solid, level, dry area that is free from debris and other foreign objects.
2. Clear the area of bystanders, especially children.

WARNING

■ **Keep bystanders away from equipment.**

3. Make sure hitch pins and spacers are completely assembled to match the hitch configuration of your tractor. See Figure 2.

4. Remove 3-point hitch lower pins and upper link bolt. Back tractor and align lower links with hitch pins.

5. Stop engine, set parking brake, and wait for all moving parts to stop. Remove ignition key before dismounting.

6. Install pins with correct bushings and secure quick-lock pins. Align upper link and fasten with bolt and spacer bushing (or upper link pin for CAT II hitches).

7. Clean the hydraulic couplers and fittings to avoid oil contamination.

8. Connect hydraulic couplings. Couplings must be completely engaged.

WARNING

■ **Air in hydraulic systems can cause erratic operation and allow loads or equipment components to drop unexpectedly. When connecting equipment or hoses or performing any hydraulic maintenance, purge any air in hydraulic system by operating all hydraulic functions several times. Do this before putting into service or allowing anyone to approach the equipment.**

9. Connect wing fold hydraulic lines to the tractor #1 hydraulic couplers. Couplers must be connected so that pushing the control lever forward moves (unfolds) the wings to operating position and pulling the lever rearward moves (folds) the wings to transport position.

10. Connect lift assist hydraulic lines to the tractor #2 hydraulic couplers. Couplers must be connected so that pushing the control lever forward lowers the cultivator and pulling the lever rearward raises the cultivator.

11. Connect 7-pin electrical connector to the tractor.

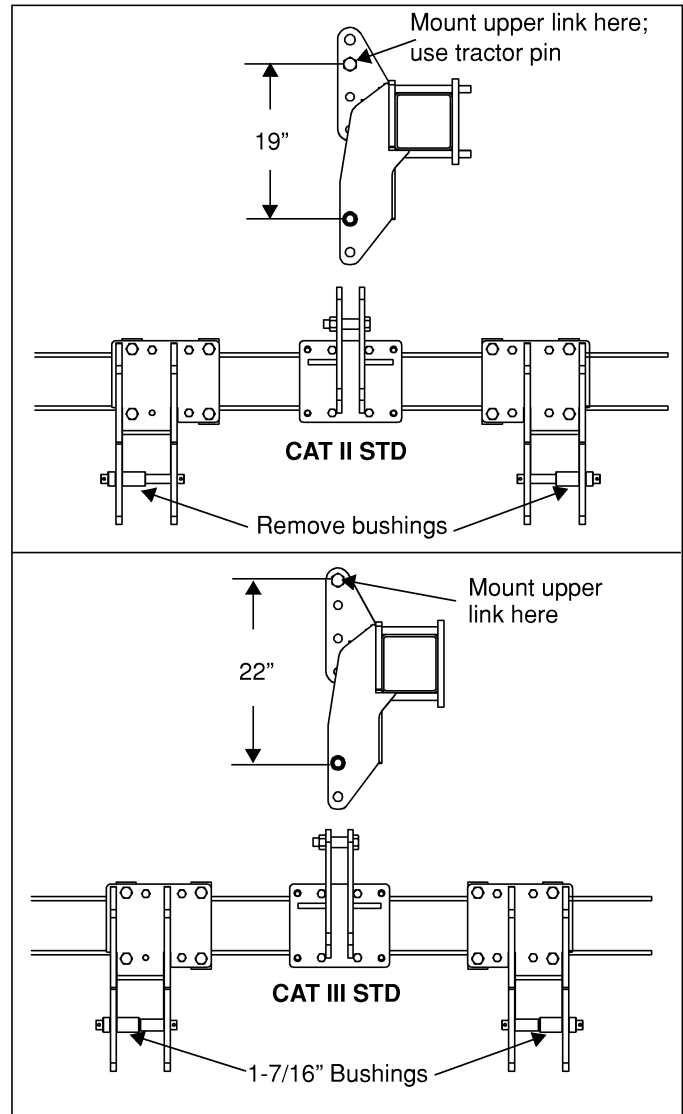

Figure 2 Standard Hitch Configuration

12. Raise the tool bar slightly.

13. Stop engine, set parking brake, and wait for all moving parts to stop. Remove ignition key before dismounting.

14. Raise all parking stands into upper position. Install pin through parking stand and bracket as shown in Figure 4.

IMPORTANT

■ **To prevent damage, raise parking stands to upper position before moving cultivator.**

■ **To prevent damage to cultivator, do not drop. Lower slowly. Dropping cultivator could result in damage to gauge wheel.**

Removing Cultivator from Tractor

Pull-Type Hitch

1. Park cultivator on a solid, level, dry area that is free from debris and other foreign objects.
2. Clear the area of bystanders, especially children.



Keep bystanders away from equipment.

3. Stop engine, set parking brake, wait for all moving parts to stop. Remove ignition key before dismounting.
4. Lower rear parking stands. Pin in position so the tool bar will be level with the hitch stored at drawbar height. See Figure 4.
5. Lower tongue jack into position.
6. From tractor cab, start engine and raise cultivator.
7. Remove transport locks. Store transport locks as shown in Figure 3.
8. Lower cultivator until weight is carried on the rear parking stands and parking jack.
9. Stop engine, set parking brake, wait for all moving parts to stop. Remove ignition key before dismounting.
10. Relieve hydraulic pressure on fold and lift cylinders.

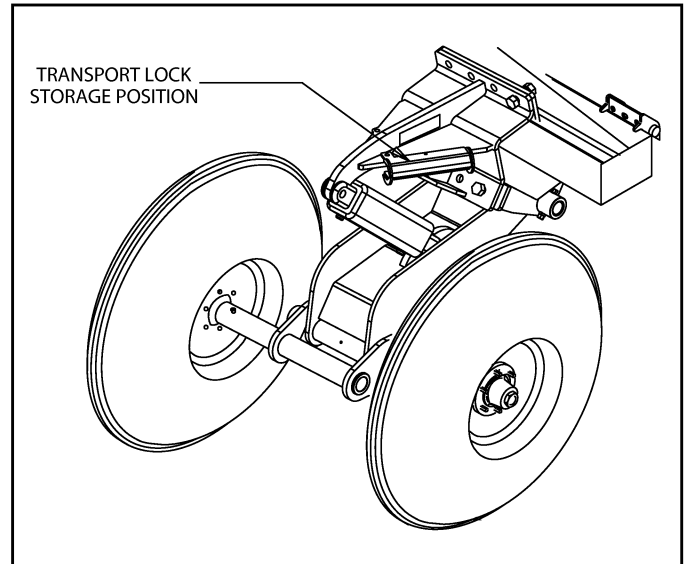

Figure 3 Storage Position

11. Unhook hydraulic lines.
12. Unhook safety chain from tractor.
13. Unhook electrical connector.
14. Remove hitch pin.
15. Start engine and slowly drive away from cultivator.
16. Stop engine, set parking brake, and remove key.

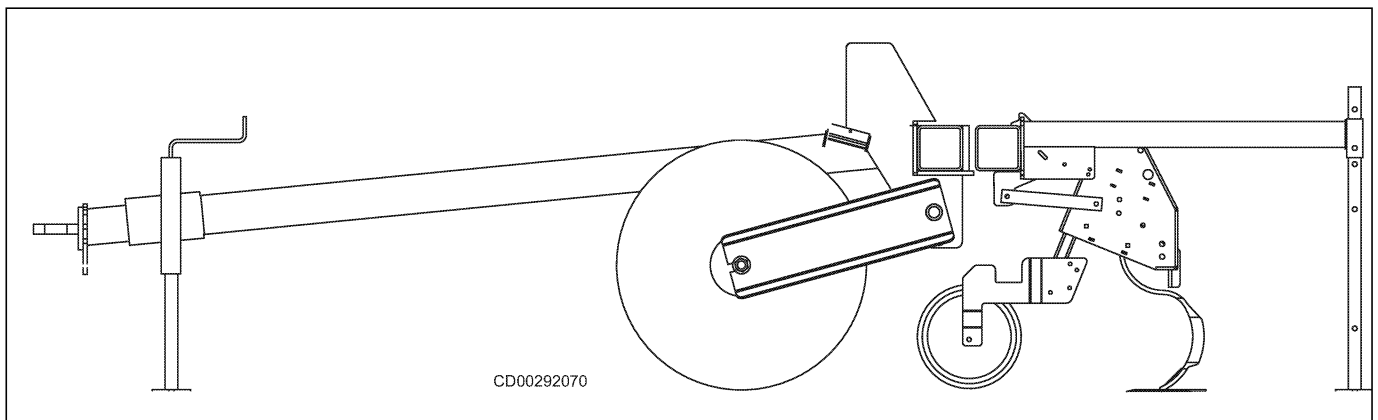

Figure 4 Rear parking stand lowered and pinned
Tongue jack in correct position for storing cultivator

Removing Cultivator from Tractor

Rigid Cultivators or Wing Cultivators Removed in Operating Position (WINGS UNFOLDED)

WARNING

■ Implement can tip over and crush if attached, removed, or stored improperly.

- Read and follow instructions and safety rules for procedures and use of parking stands.
- Front parking stands must be on all cultivators.
- Rear parking stands must be on all folding cultivators unless cultivator has rear lift assist.
- Parking stands must be kept in good condition and replaced if damaged.
- Remove on solid, level ground.
- Before removing from tractor, cultivator must be level and stable with parking stands properly positioned and rear lift assist (when equipped) lowered to rest on cylinder stops.
- Keep all bystanders away.

■ Keep bystanders away from equipment.

1. Park cultivator on a solid, level, dry area that is free from debris and other foreign objects.
2. Make sure bystanders are clear from working area.
3. Lower lift assist wheels (if equipped) to rest on cylinder stops.
4. Lower cultivator so that sweeps and gauge or guide wheels rest on the ground. Position toolbar in the operating position so that cultivator linkage is nearly horizontal. See Figure 5.
5. Stop engine, set parking brake, and wait for all moving parts to stop. Remove ignition key before dismounting.
6. Lower front parking stands to the ground and pin in position so that parking stands will be vertical when the tractor is removed. See Figure 6.
7. Relieve hydraulic pressure in wing fold and lift assist cylinders (if equipped).
8. Adjust center link as necessary to remove load from hitch.
9. With Quick-Hitch: Release coupler latches and lower hitch to release hitch pins.
10. Without Quick-Hitch: Remove hitch pins from upper and lower hitch links.

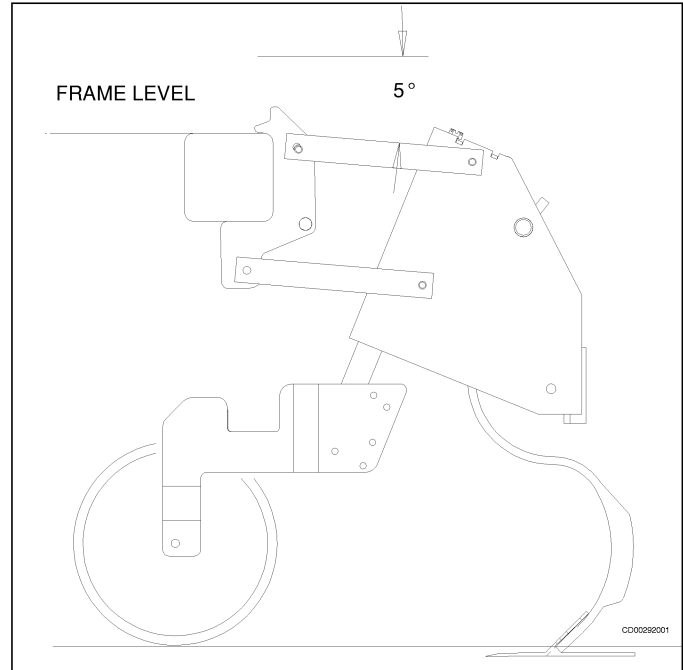

Figure 5 Operating Position

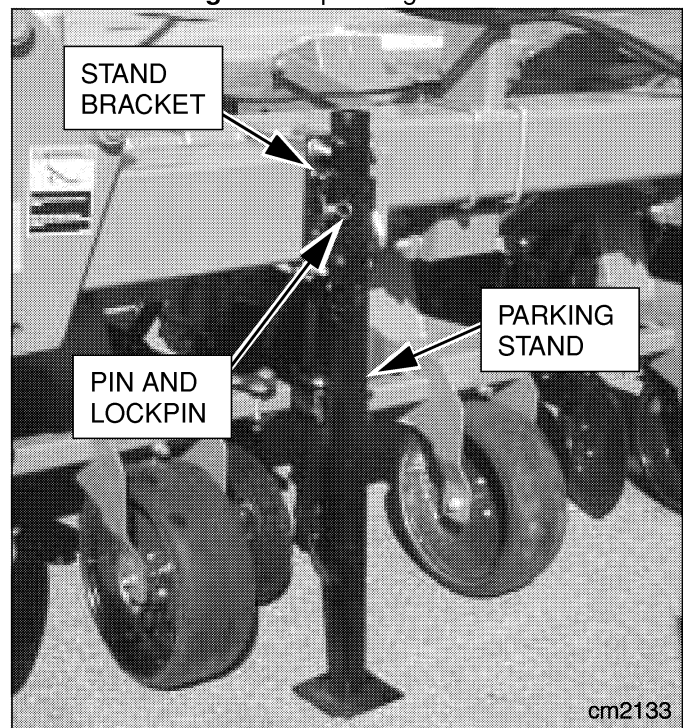

Figure 6 Front Parking Stand Lowered and Pinned

11. Disconnect hydraulic couplers and electrical connector from tractor.

12. Start engine and slowly drive away from cultivator.

Operation *Cont'd*

Removing Cultivator from Tractor

Wing Cultivators Removed in Transport Position (WINGS FOLDED)

WARNING

■ Implement can tip over and crush if attached, removed, or stored improperly.

- Read and follow instructions and safety rules for procedures and use of parking stands.
- Front parking stands must be on all cultivators.
- Rear parking stands must be on all folding cultivators unless cultivator has rear lift assist.
- Parking stands must be kept in good condition and replaced if damaged.
- Remove on solid, level ground.
- Before removing from tractor, cultivator must be level and stable with parking stands properly positioned and rear lift assist (when equipped) lowered to rest on cylinder stops.
- Keep all bystanders away.

■ Keep bystanders away from equipment.

1. Park cultivator on a solid, level, dry area that is free from debris and other foreign objects.

2. Clear the area of bystanders, especially children.

3. Lower lift assist wheels (if equipped) to rest on cylinder stops.

4. Lower cultivator so that sweeps and gauge or guide wheels rest on the ground. Position toolbar in the operating position so that cultivator linkage is nearly horizontal. See Figure 7.

5. Stop engine, set parking brake, and wait for all moving parts to stop. Remove ignition key before dismantling.

6. Lower front parking stands to the ground and pin in position so that parking stands will be vertical when the tractor is removed.

7. Lower rear parking stands (folding cultivators without lift assist) to the ground and pin in position so that parking stands will be vertical when tractor is removed. Front and rear stands should be pinned in the same hole position. See Figure 8.

8. Relieve hydraulic pressure in wing fold and lift assist cylinders.

9. Adjust center link as necessary to remove load from hitch.

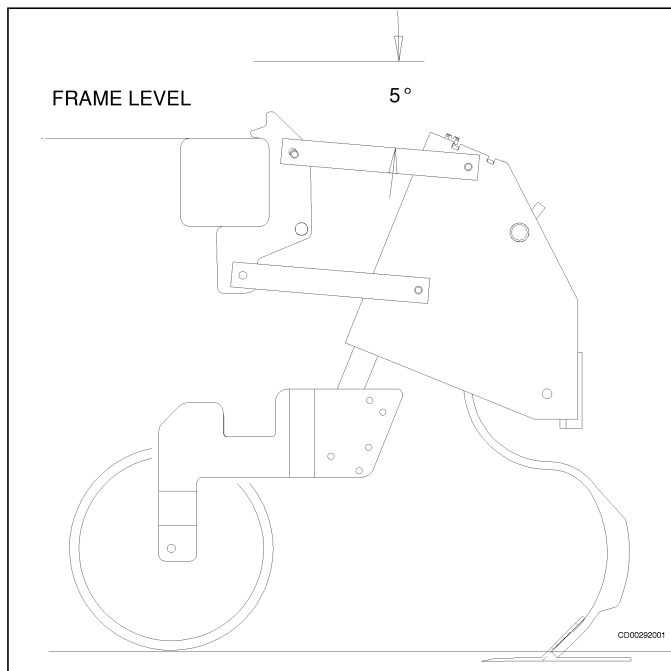

Figure 7 Operating Position

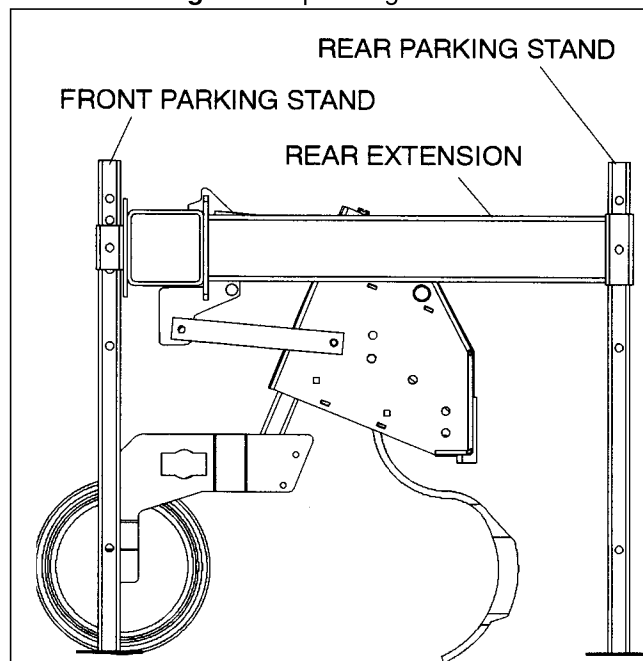

Figure 8 Front & Rear Parking Stands (Type F Toolbar)

10. With Quick-Hitch: Release coupler latches and lower hitch to release hitch pins.

11. Without Quick-Hitch: Remove hitch pins from upper and lower hitch links.

12. Disconnect hydraulic couplers and electrical connector from tractor.

13. Start engine and slowly drive away from cultivator.

Removing Cultivator from Tractor

Wing Cultivators Equipped with Lift Assist Wheels

WARNING

■ Implement can tip over and crush if attached, removed, or stored improperly.

- Read and follow instructions and safety rules for procedures and use of parking stands.
- Front parking stands must be on all cultivators.
- Rear parking stands must be on all folding cultivators unless cultivator has rear lift assist.
- Parking stands must be kept in good condition and replaced if damaged.
- Remove on solid, level ground.
- Before removing from tractor, cultivator must be level and stable with parking stands properly positioned and rear lift assist (when equipped) lowered to rest on cylinder stops.
- Keep all bystanders away.

■ Keep bystanders away from equipment.

1. Park cultivator on a solid, level, dry area that is free from debris and other foreign objects.
2. Clear the area of bystanders, especially children.
3. Lower lift assist wheels to rest on cylinder stops.
4. Lower cultivator so that sweeps and gauge or guide wheels rest on the ground. Position toolbar in the operating position so that cultivator linkage is nearly horizontal. See Figure 9.
5. Stop engine, set parking brake, and wait for all moving parts to stop. Remove ignition key before dismounting.
6. Lower front parking stands to the ground and pin in position so that parking stands will be vertical when the tractor is removed. See Figure 10.
7. Relieve hydraulic pressure in wing fold and lift assist cylinders.
8. Adjust center link as necessary to remove load from hitch.
9. With Quick-Hitch: Release coupler latches and lower hitch to release hitch pins.
10. Without Quick-Hitch: Remove hitch pins from upper and lower hitch links.

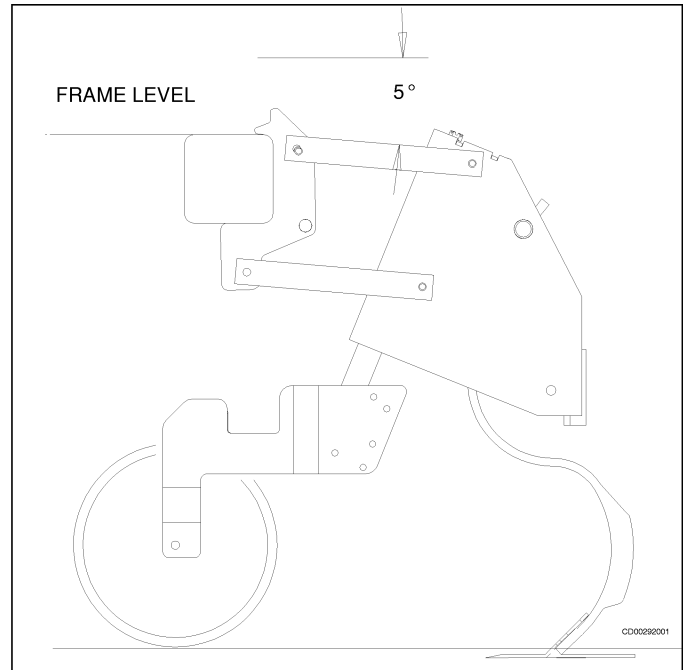

Figure 9 Operating Position

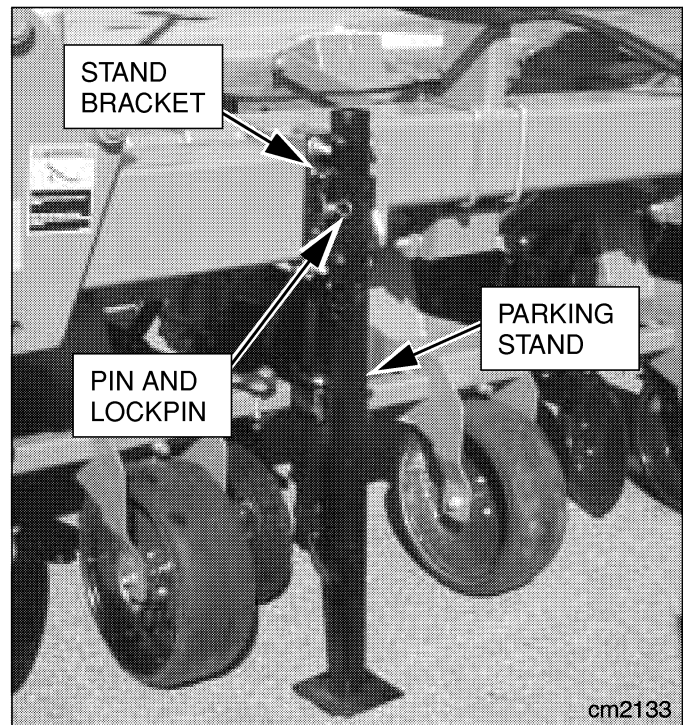

Figure 10 Front Parking Stand Lowered and Pinned

11. Disconnect hydraulic couplers and electrical connector from tractor.

12. Start engine and slowly drive away from cultivator.

Operation *Cont'd*

Electrical System

The tractor must be equipped with an SAE J560a 7-pin electrical connector. This will provide power for turn signals, warning flashers, and tail lights.

The cultivator is equipped with warning flashers and turn signals, located on each end of the main tool bar. Warning lights must be functional whenever transporting on public highways.

See your tractor operator's manual for instructions on warning light and turn signal operation.

If warning lights, turn signals, and tail lights do not function correctly, see your Alloway dealer.

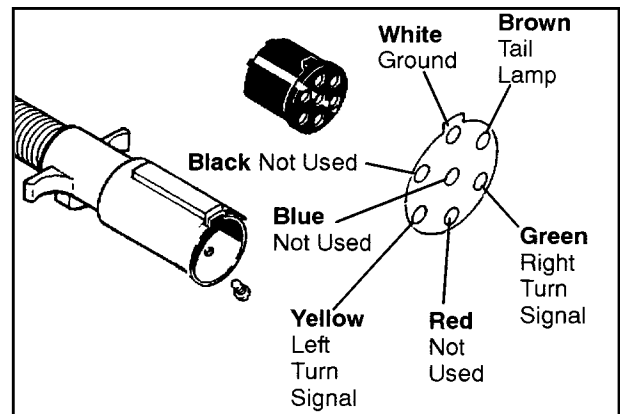

Figure 11 7-Pin Electrical Connector

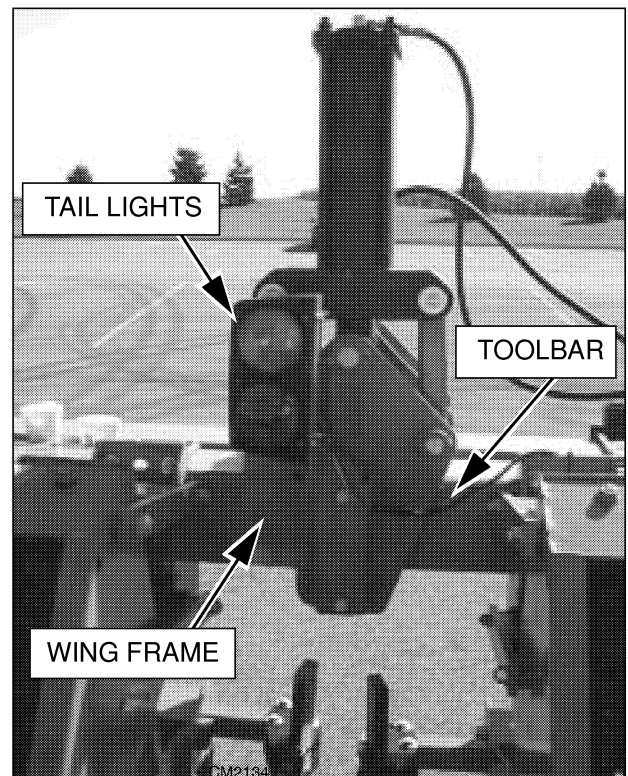

Figure 12 Tail Light (Folding Bar, left side shown)

Operation *Cont'd*

Front Parking Stands

Front parking stands are supplied with all 3130 cultivators. Front stands must be installed to support the cultivator whenever it is removed from the tractor.

1. Lower front parking stands to the ground and pin in position so that parking stands will be vertical when the tractor is removed. See Figure 13.

Rear Parking Stands

Rear parking stands are supplied with all folding toolbar 3130 cultivators without rear lift assist wheels. Either rear parking stands or lift assist wheels must be installed to support the cultivator whenever it is removed in the folded transport position.

1. Lower rear parking stands (folding cultivators without lift assist) to the ground and pin in position so that parking stands will be vertical when tractor is removed. Front and rear stands should be pinned in the same hole position as shown in Figure 13.

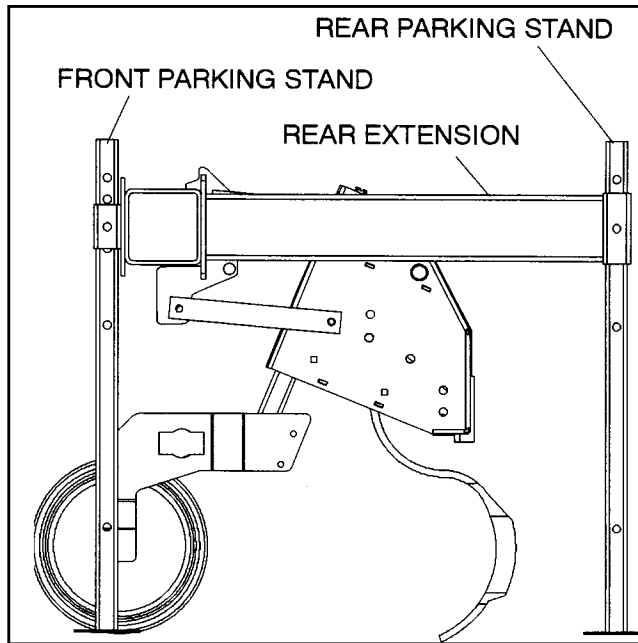

Figure 13 Front & Rear Parking Stands (type F toolbar)

Folding the Cultivator

WARNING

- **Never walk, stand, or place yourself or others under a raised wing or in the path of a lowering wing. Hydraulic system leak-down, hydraulic system failures, mechanical failures, or movement of control levers can cause wings to drop unexpectedly and cause severe injury or death.**
 - **Before folding or unfolding cultivator:**
 - **Make sure you have adequate clearance on each side and overhead.**
 - **Make sure wing cylinder restrictor fittings are properly installed.**
 - **Make sure wing-mounted gauge wheels and guide coulters will not contact tractor cab or tires.**
1. Connect wing fold hydraulic lines to the tractor #1 hydraulic couplers. Couplers must be connected so that pushing the control lever forward moves (unfolds) the wings to operating position and pulling the lever rearward moves (folds) the wings to transport position.

DANGER

- **AVOID INJURY OR DEATH FROM POWER LINES:**
 - **Stay away from power lines.**
 - **Electrocution can occur without direct contact.**
 - **Check clearances before raising implement.**
 - **Do not leave the operator's seat if any part of the tractor or implement contacts electric lines.**
2. Position the tractor and cultivator in a level area, free of overhead obstacles.
 3. Use the tractor 3-point hitch and lift assist wheels (if equipped) or pull-type hitch to raise the cultivator to a level position off the ground.
 4. Activate fold control lever rearward and move the cultivator wings until they contact the wing rests that are attached to the main frame. Raise the cultivator into transport position.

Unfolding the Cultivator

WARNING

■ Never walk, stand, or place yourself or others under a raised wing or in the path of a lowering wing. Hydraulic system leak-down, hydraulic system failures, mechanical failures, or movement of control levers can cause wings to drop unexpectedly and cause severe injury or death.

■ Before folding or unfolding cultivator:

- Make sure you have adequate clearance on each side and overhead.
- Make sure wing cylinder restrictor fittings are properly installed.
- Make sure wing-mounted gauge wheels and guide coulters will not contact tractor cab or tires.

1. Connect wing fold hydraulic lines to the tractor #1 hydraulic couplers. Couplers must be connected so that pushing the control lever forward moves (unfolds) the wings to operating position and pulling the lever rearward moves (folds) the wings to transport position.

2. Position the tractor and cultivator in a level area, free of overhead obstacles and with enough clear area to permit the cultivator to unfold.

DANGER

■ **AVOID INJURY OR DEATH FROM POWER LINES:**

- Stay away from power lines.
- Electrocutation can occur without direct contact.
- Check clearances before raising implement.
- Do not leave the operator's seat if any part of the tractor or implement contacts electric lines.

3. Use the tractor 3-point hitch and lift assist wheels (if equipped) or pull-type hitch to raise the cultivator to a level position off the ground.

4. Activate fold control lever forward and move the cultivator wings off wing rests into operating position.

5. Move tractor into position for cultivating.

Connecting Lift Assist

3-Point Hitch Semi-Mounted Cultivator

IMPORTANT

■ If the cultivator is used with lift assist wheels, it must be operated as a semi-mounted unit to prevent damage to the 3-point hitch components. Remove the upper link mast and attach the cultivator to the lower 3-point hitch links only. Lift assist wheels will always carry part of the cultivator weight.

1. Connect lift assist hydraulic lines to the tractor #2 hydraulic couplers. Couplers must be connected so that pushing the control lever forward lowers the cultivator and pulling the lever rearward raises the cultivator.

2. Use the adjustment nuts on the lift assist cylinders to level and control the operating position of the rear of the cultivator.

3. When storing the folding cultivator in the transport position, lower lift assist wheels to rest on the cylinder stops and front parking stands installed as described in Removing Cultivator from Tractor, page 18.

FIELD OPERATION

WARNING

■ A minimum 20% of tractor and equipment weight must be on the tractor front wheels when attachments are in transport position. Without this weight, tractor could tip over, causing personal injury or death. The weight may be attained with a loader, front wheel weights, ballast in tires or front tractor weights. Weigh the tractor and equipment. Do not estimate.

IMPORTANT

- Raise cultivator out of the ground when making sharp turns.
- Do not back up with sweeps or tools in the ground.

1. Enter the field and straddle rows in the same direction of planter travel.
2. Make sure no one is near the cultivator when raising or lowering wings.
3. Unfold into operating position.
4. Lower cultivator slowly and move forward approximately 20 feet.

IMPORTANT

■ To prevent damage to cultivator, do not drop. Lower slowly. Dropping cultivator could result in damage to gauge wheel.

5. Check shovel working depth by brushing worked soil aside to determine the amount of ground penetration. Shovel depth is adjusted by raising or lowering the gauge wheel on each gang. Gangs behind tractor wheels are often adjusted deeper to loosen compacted soil.

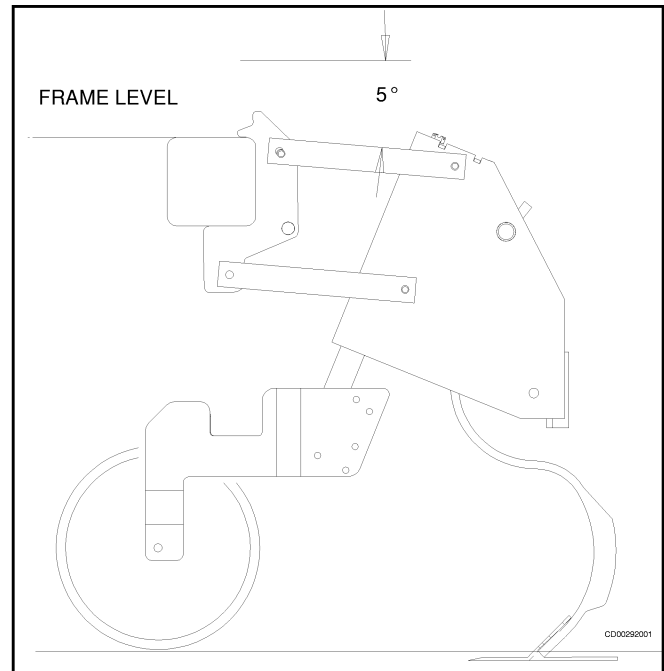

Figure 14 Operating Position

6. If necessary, readjust tine placement for proper coverage.
7. After establishing working depth, it may be necessary to reset the 3-point lever stop and adjust the support wheels or to adjust the stops on pull-type wheel cylinders to maintain operating position as shown in Figure 14.
8. To adjust individual attachments, refer to MAKING ADJUSTMENTS, page 26 to page 29.

STORAGE



- **Block equipment securely for storage.**
- **Keep children and bystanders away from storage area.**

At the end of the season, the cultivator should be thoroughly inspected and prepared for storage. Repair or replace any worn or damage components to prevent unnecessary down time at the beginning of the next season.

To ensure a long, trouble-free life, prepare the unit for storage by carrying out the following procedure:

1. Clear the area of bystanders, especially children.
2. On solid, level ground, lower unit to rest in a stable level position with parking stands properly positioned.
3. Stop engine, set parking brake, and wait for all moving parts to stop. Remove ignition key before dismounting.
4. Thoroughly wash the unit, using a pressure washer to remove all dirt, mud, debris, and residue.
5. Repair or replace damaged parts. Remove any entangled material.
6. Inspect all hydraulic hoses, lines, couplers, and fittings. Tighten all loose fittings. Replace any hose that is badly cut, nicked, abraded, or separating from the crimped end of a fitting.
7. Lubricate all grease fittings. Make sure all grease cavities have been filled with grease to remove any water residue from pressure washing. Touch up all paint nicks and scratches to prevent rust.
8. Move to storage area. Select a dry area free of debris. Store in an area away from human activity.
9. Unhook from tractor (see Removing Cultivator from Tractor, page 17).

NOTE: Do not deflate tires.

10. Store the unit away from human activity
11. Do not allow children to play on or around the stored unit.

TRANSPORTING



■ Always comply with all state and local lighting and marking requirements.

1. Make sure all bystanders are clear of the unit.
2. Make sure the unit is securely attached to the tractor and all retainer pins are installed.
3. Make sure safety chain is installed on pull-type model.
4. Raise the unit.
5. Check the tire pressure. Be sure tires are at specified pressure.
6. Install transport locks on pull-type cultivator.
7. Make sure you are in compliance with all applicable lighting and marking regulations when transporting. Check with your local authorities.
8. Never transport the unit faster than 10 mph (16 kmph).
9. Know the transport height and width of your unit.
10. Stay clear of overhead power lines when folding and unfolding unit. Electrocution can occur without direct contact.

MAKING ADJUSTMENTS

Leveling Toolbar Wings

1. Level wings to center toolbar, using leveling bolts.
2. Tighten jam nuts when wings are level.

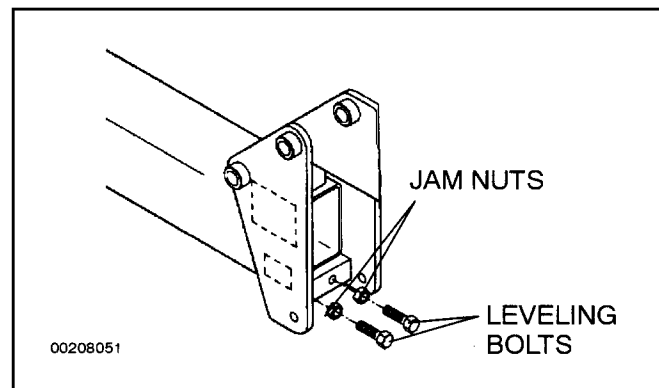

Figure 15 Toolbar Wings

Operation *Cont'd*

Adjusting Gangs

1. Keep cultivator frame level with ground by adjusting upper link on tractor to maintain consistent ground penetration of each tine.
2. Adjust tractor 3-point hitch and frame gauge wheels so that cultivator linkage operates approximately 5 degrees from level as shown in Figure 16.
3. Set working depth by adjusting gauge wheel. Turn adjusting nut clockwise to increase working depth and counterclockwise to decrease working depth.
4. Set tine pitch by adjusting tine pitch adjustment screw as shown in Figure 17.

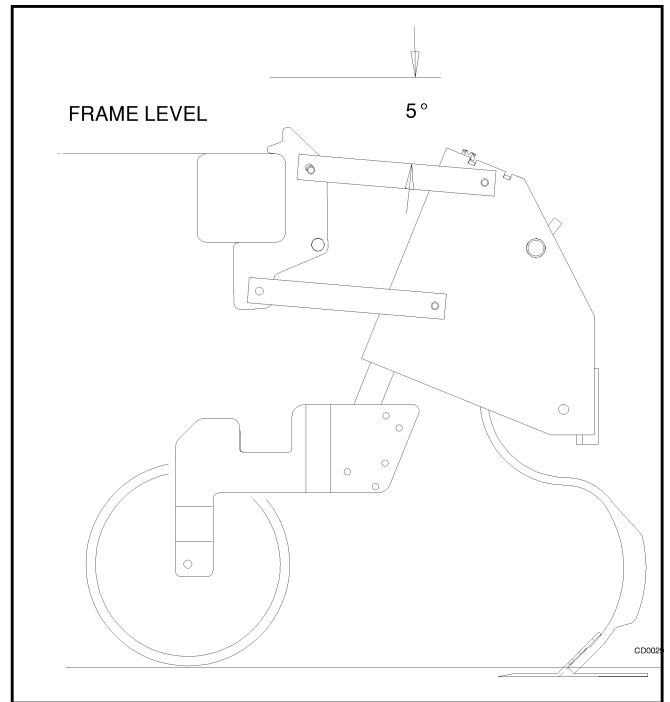

Figure 16 Operating Position

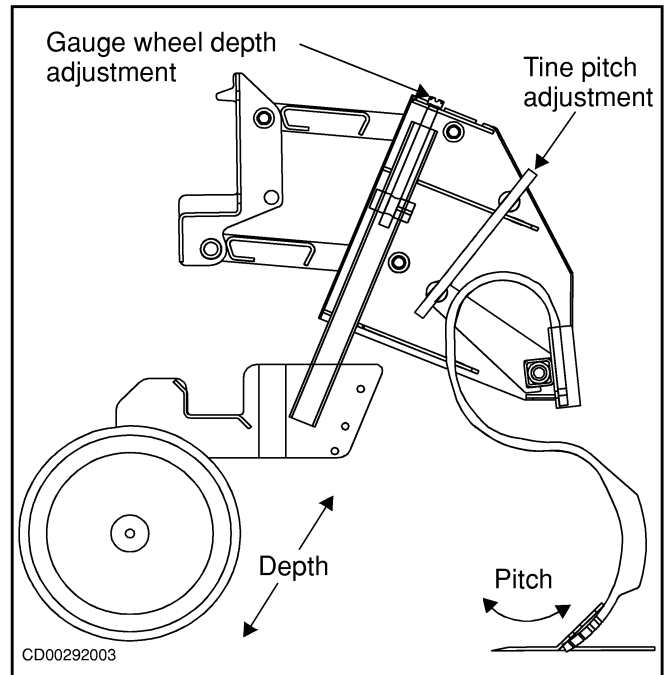

Figure 17 Gang Adjustment

Adjusting Support Wheels

Center Frame Support Wheels

The toolbar weight should be split between the tractor 3-point and the support wheels. To provide level operation of the toolbar, adjust the support wheels mounted on rigid toolbars or on the center section of folding toolbars.

Use field conditions and desired cultivator performance to set support wheel operating height.

1. Shorten the screwjack to lower to toolbar. Lengthen the screwjack to raise the toolbar. See Figure 18.

Wing Support Wheels

To maintain a proper working height at the outer end of the toolbar's wings, position and adjust the support wheels. Re-adjust the wing support wheels if the center frame operating position is changed.

1. Shorten the screwjack to lower to toolbar. Lengthen the screwjack to raise the toolbar. See Figure 18.

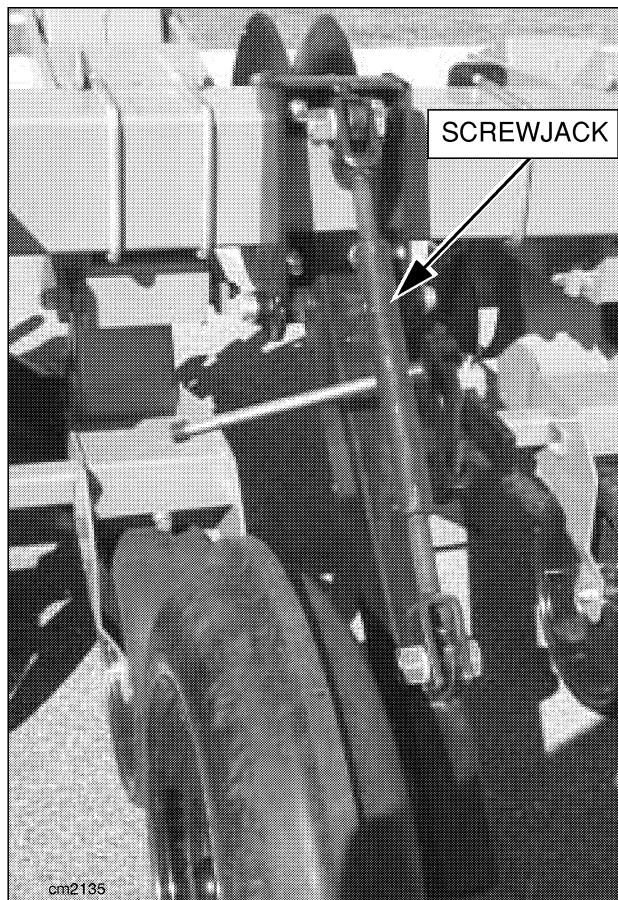

Figure 18 Adjusting Support Wheels

Operation *Cont'd*

Adjusting Dual Discs

1. Adjust disc width by loosening bolts and jam nuts on top of the disc clamp.
2. Slide discs on rails until reaching desired width.
3. Tighten bolts and jam nuts.

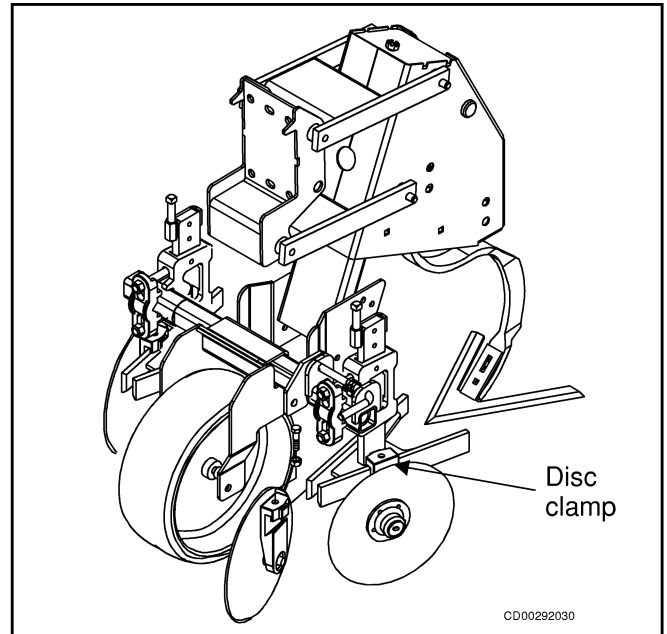

Figure 19 Adjusting Dual Discs

Adjusting Sweeps

1. Adjust pitch by selecting a different hole on the tine (straight edge tine). Use pitch adjusting screw. See Figure 20.

Adjusting Optional Equipment

Refer to ASSEMBLY section for instructions on adjusting additional optional attachments.

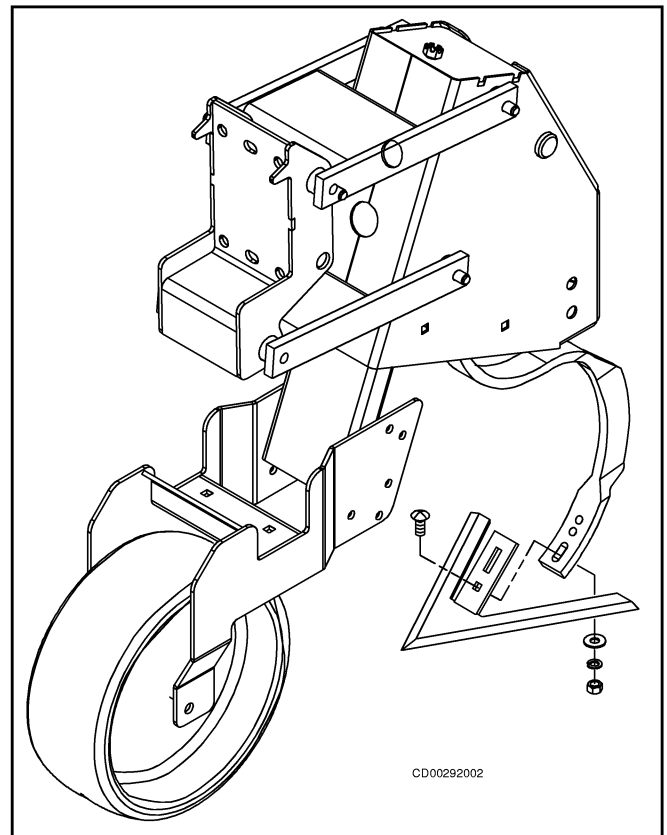

Figure 20 Adjusting Sweep Pitch

SERVICE

WARNING

■ **NEVER GO UNDERNEATH EQUIPMENT.** Never place any part of the body underneath equipment or between moveable parts even when the engine has been turned off. Hydraulic system leak down, hydraulic system failures, mechanical failures, or movement of control levers can cause equipment to drop or rotate unexpectedly and cause severe injury or death.

- Service work does not require going underneath.
- Read Operator's Manual for service instructions or have service performed by a qualified dealer.

■ **Know your controls and how to stop engine and attachment quickly in an emergency.**

■ **Keep hands and body away from pressurized lines.** Use paper or cardboard, not hands or other body parts to check for leaks. Wear safety goggles. Hydraulic fluid under pressure can easily penetrate skin and will cause serious injury or death.

■ **Make sure that all operating and service personnel know that if hydraulic fluid penetrates skin, it must be surgically removed as soon as possible by a doctor familiar with this form of injury or gangrene, serious injury, or death will result. CON-**

TACT A PHYSICIAN IMMEDIATELY IF FLUID ENTERS SKIN OR EYES. DO NOT DELAY.

■ **Never allow children or untrained persons to operate equipment.**

■ **Do not allow bystanders in the area when operating, attaching, removing, assembling, or servicing equipment.**

■ **Before dismounting power unit or performing any service or maintenance, follow these steps: disengage power to implement, lower the 3-point hitch and all raised components to the ground, operate valve levers to release any hydraulic pressure, set parking brake, stop engine, remove key, and unfasten seat belt.**

■ **Before servicing, unfold completely to operating position. Do not service with wings in any other position.**

CAUTION

■ **If you do not understand any part of this manual and need assistance, see your dealer.**

■ **Always wear relatively tight and belted clothing to avoid entanglement in moving parts. Wear sturdy, rough-soled work shoes and protective equipment for eyes, hair, hands, hearing, and head.**

Greasing

Use an SAE multi-purpose high temperature grease with extreme pressure (EP) performance. An SAE multi-purpose lithium-based grease is also acceptable.

1. Use a hand-held grease gun for all greasing.
2. Wipe grease fitting with a clean cloth before greasing to avoid injecting dirt and grit.
3. Replace and repair broken fittings immediately.
4. If fittings will not take grease, remove and clean thoroughly. Also clean lubricant passageway. Replace fitting if necessary.

Storing Lubricants

Your unit can operate at top efficiency only if clean lubricants are used. Use clean containers to handle all lubricants. Store them in an area protected from dust, moisture, and other contaminants.

The recommended lubrication intervals are based on normal operating conditions. Severe or unusual conditions may require more frequent lubrication.

Service & Maintenance *Cont'd*

Servicing Intervals

10 Hours

Lubricate 180-degree folding toolbar (Figure 21).

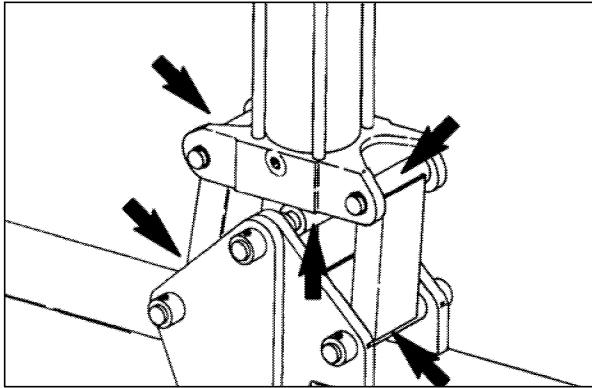

Figure 21

25 Hours

Lubricate guide wheel screw jacks (Figure 22 & Figure 24).

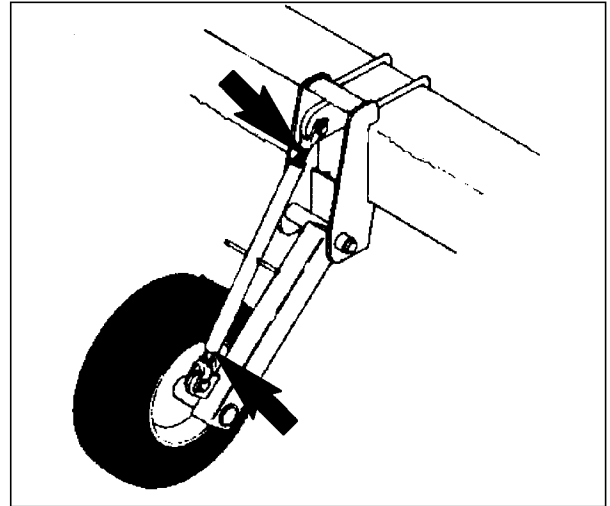

Figure 22

25 Hours

Lubricate lift assist assemblies (Figure 23)

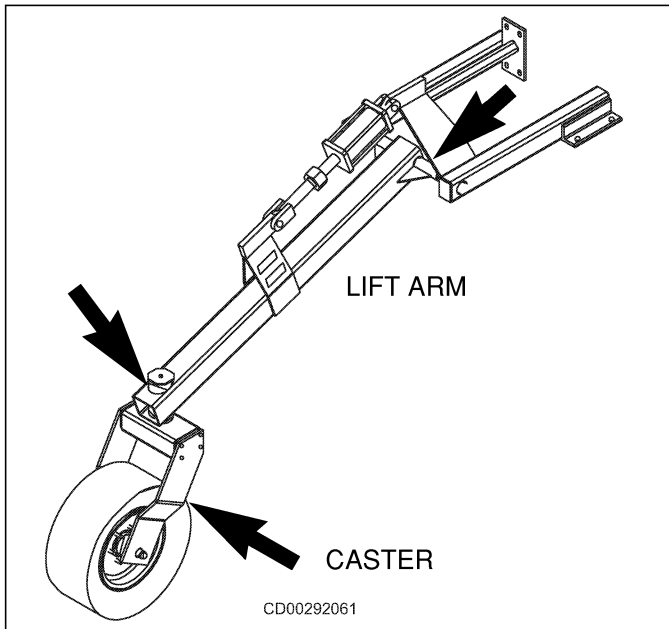

Figure 23

25 Hours

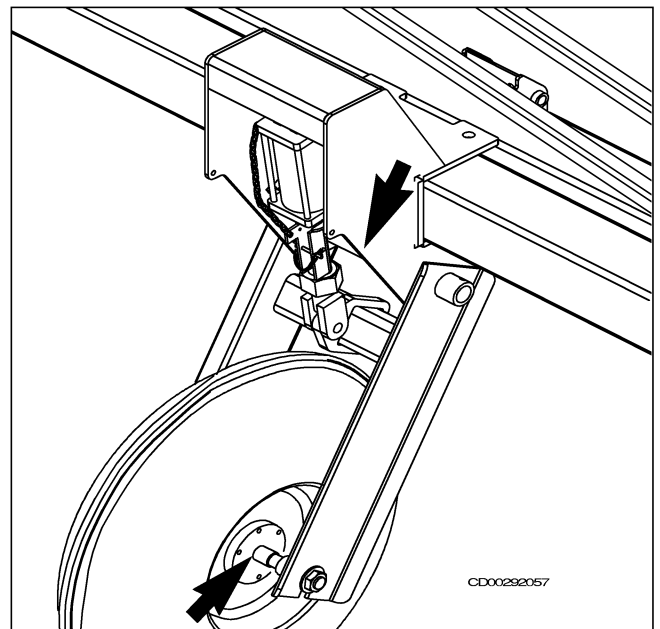

Figure 24 Pull-type Hitch

Service & Maintenance *Cont'd*

Servicing Intervals (Cont'd)

Annually

Repack all wheel bearings.

Lubricate dual knife disc mounting tubes (Figure 25).

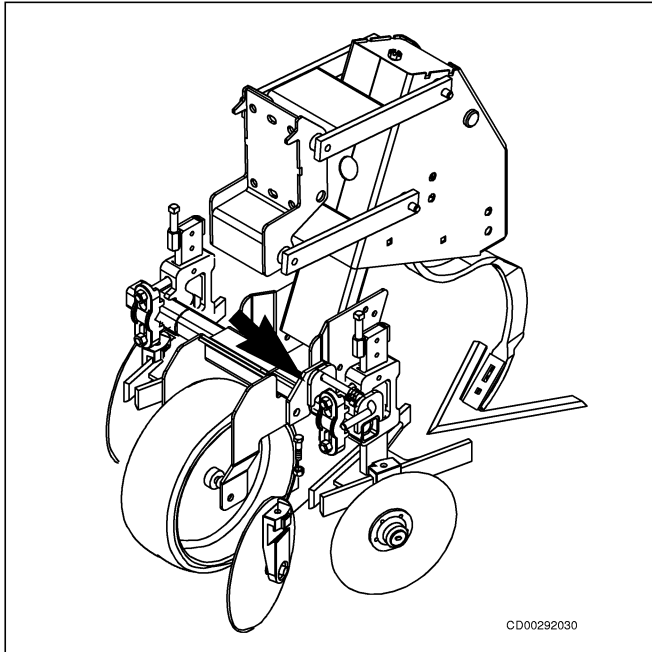

Figure 25

ASSEMBLY

DEALER SET-UP INSTRUCTIONS

WARNING

■ Keep hands and body away from pressurized lines. Use paper or cardboard, not hands or other body parts to check for leaks. Wear safety goggles. Hydraulic fluid under pressure can easily penetrate skin and will cause serious injury or death.

■ Make sure that all operating and service personnel know that if hydraulic fluid penetrates skin, it must be surgically removed as soon as possible by a doctor familiar with this form of injury or gangrene, serious injury, or death will result. **CONTACT A PHYSICIAN IMMEDIATELY IF FLUID ENTERS SKIN OR EYES. DO NOT DELAY.**

■ Air in hydraulic systems can cause erratic operation and allow loads or equipment components to drop unexpectedly. When connecting equipment or hoses or performing any hydraulic maintenance, purge any air in hydraulic system by operating all hydraulic functions several times. Do this before putting into service or allowing anyone to approach the equipment.

■ Before folding or unfolding cultivator:

- Make sure you have adequate clearance on each side and overhead.
- Make sure wing cylinder restrictor fittings are properly installed.
- Make sure wing-mounted gauge wheels and guide coulters will not contact tractor cab or tires.

■ Never allow children or untrained persons to operate equipment.

■ Do not allow bystanders in the area when operating, attaching, removing, assembling, or servicing equipment.

■ Before dismounting power unit or performing any service or maintenance, follow these steps: disengage power to implement, lower the 3-point hitch and all raised components to the ground, operate valve levers to release any hydraulic pressure, set parking brake, stop engine, remove key, and unfasten seat belt.

WARNING

■ Do not handle blades with bare hands. Careless or improper handling may result in serious injury.

CAUTION

■ Always wear relatively tight and belted clothing to avoid entanglement in moving parts. Wear sturdy, rough-soled work shoes and protective equipment for eyes, hair, hands, hearing, and head.

Assembly of this cultivator is the responsibility of the Alloway dealer. The cultivator should be delivered to the owner completely assembled, lubricated, and adjusted for normal conditions.

Set up cultivator as received from the factory with these instructions. Complete the check lists on page 34 when set-up is completed.

Cultivators are shipped disassembled. When you receive shipment, examine the unit carefully for any hidden damage during shipment. Before assembling the unit, check and compare the parts, bundles, and cartons against the packing list to identify any shortages. If any parts shortages are noted, contact Alloway immediately.

1. Select an assembly location that is clean and level with a firm, dry surface. The area must not have any overhead power lines or obstructions and must be large enough to work safely around the unit and to accommodate the unit when fully assembled.

2. Remove cultivator from the carton. Open the parts box and lay parts out for easy identification. Refer to the parts lists and exploded view drawings in this manual.

NOTE: Recommended torque values are given in the Bolt Torque Chart, page 94.

PRE-DELIVERY CHECK LIST (DEALER'S RESPONSIBILITY)

Inspect the equipment thoroughly after assembly to make sure that it is set up properly before delivering it to the customer.

The following check lists are a reminder of points to inspect. Check off each item as it is found satisfactory or after proper adjustment is made.

- ___ Check that all safety decals are installed and in good condition. Replace if damaged.
- ___ Properly attach implement to tractor and make all necessary adjustments.
- ___ Check all bolts to be sure they are properly torqued.
- ___ Check wheel bolts for proper torque.
- ___ Check that all cotter pins and safety pins are properly installed. Replace if damaged.
- ___ Check and grease all lubrication points as identified in Servicing Intervals, page 31 and page 32.
- ___ Check that hydraulic reservoir has been serviced and that hydraulic system and all functions have been operated through full cylinder stroke to purge air from system.

DELIVERY CHECK LIST (DEALER'S RESPONSIBILITY)

- ___ Show customer how to make adjustments.
- ___ Instruct customer how to lubricate and explain the importance of lubrication.
- ___ Point out the safety decals. Explain their meaning and the need to keep them in place and in good condition. Emphasize the increased safety hazards when instructions are not followed.
- ___ Present Operator's Manual and request that customer and all operators read it before operating equipment. Point out the manual safety rules, explain their meanings and emphasize the increased safety hazards that exist when safety rules are not followed.
- ___ Explain to customer the potential crushing hazards of going underneath raised equipment. Instruct customer that service work does not require going underneath unit and never to do so.
- ___ Show customer the safe, proper procedures to be used when mounting, dismounting, and storing equipment.
- ___ For mounted units, add wheel weights, ballast in front tires, and/or front tractor weight to enhance front end stability. A minimum 20% of tractor and equipment gross weight must be on front tractor wheels. When adding weight to attain 20% of tractor and equipment weight on front tractor wheels, you must not exceed the ROPS weight certification. Weigh the tractor and equipment. Do not estimate!
- ___ Explain to customer that when equipment is transported on a road or highway, a Slow Moving Vehicle (SMV) sign should be used to provide adequate warning to operators of other vehicles.
- ___ Make customer aware of optional equipment available so that customer can make proper choices as required.

Assembly Cont'd

ORDER OF ASSEMBLY

Completely assemble two rows of the cultivator, including all options and accessories, before assembling the entire cultivator. Once you have assembled two rows and approve the configuration, continue assembling the balance of the cultivator. **NOTE:** Application and conditions will determine the exact assembly.

Assemble the cultivator in the following order:

1. Apply Alloway decal, page 35.
2. Mount either 3-point or pull-type hitch, page 36 - 38.
3. Assemble toolbar (folding units only), page 39.
4. Install lights, page 42.
5. Mount row units to toolbar, page 42.
6. Mount shovels or sweeps, page 44.
7. Mount King guide row units, page 45.
8. Install down pressure springs (optional), page 46.
9. Attach rear shanks, page 47.
10. Attach rear extension brackets and shanks (optional) page 47.
11. Mount coulter discs (optional), page 48.
12. Mount semi-pneumatic or steel guide wheels, page 50.
13. Mount front and rear parking stands, page 51.
14. Mount adjustable support wheels, page 52.
15. Install shields, page 53 to 56.
16. Install flip-up tubes and dual discs/dual knives, page 57 to page 60.
17. Install row weeder discs or other options, page 59 to 61.
18. Mount lift assist (optional), page 62.
19. Mount rear stabilizer coulter, page 64.
20. Tighten all bolts to specifications in the Bolt Torque Chart, page 94.
21. Check that all tire pressures are 28-32 psi (38-42 psi for pull-type transport wheels).

Apply Alloway Decal

All safety and reflector decals are applied at the factory. All model decals are to be applied by the dealer.

NOTE: To avoid interference with the cultivator components, apply all other decals after assembling cultivator. On row spacings 36" and above, the Alloway decal can be applied after assembling cultivator.

1. Be sure installation area is clean and dry.
2. Decide on exact position before removing backing paper. The Alloway decal will be placed on the front right side of the toolbar as shown in Figure 1.
3. Remove the smallest portion of the split backing paper.
4. Align decal and carefully press the small portion with the exposed sticky backing in place.
5. Slowly peel back the remaining paper and carefully smooth the remaining portion of the decal in place.
6. Small air pockets can be pierced with a pin and smoothed out, using the decal backing paper.

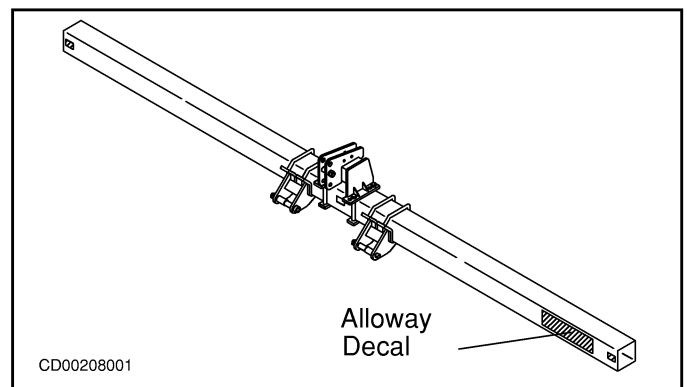

Figure 1 Alloway Decal Position

MOUNT HITCHES

Identify Toolbar Type

1. Support the toolbar on suitable stands.
2. Identify toolbar type according to Figure 2. Locate center point and mark for reference during assembly.

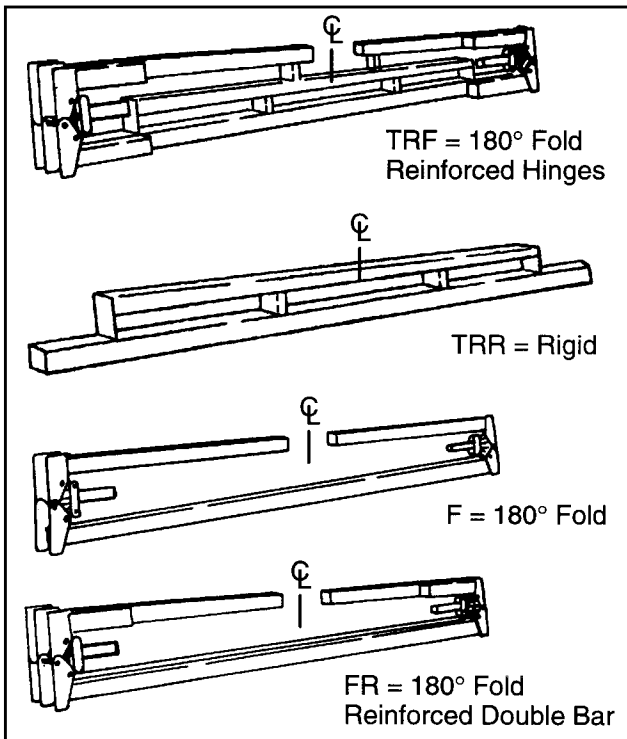

Figure 2 Toolbar Identification

3. Identify hitch mounting positions according to Figure 3.

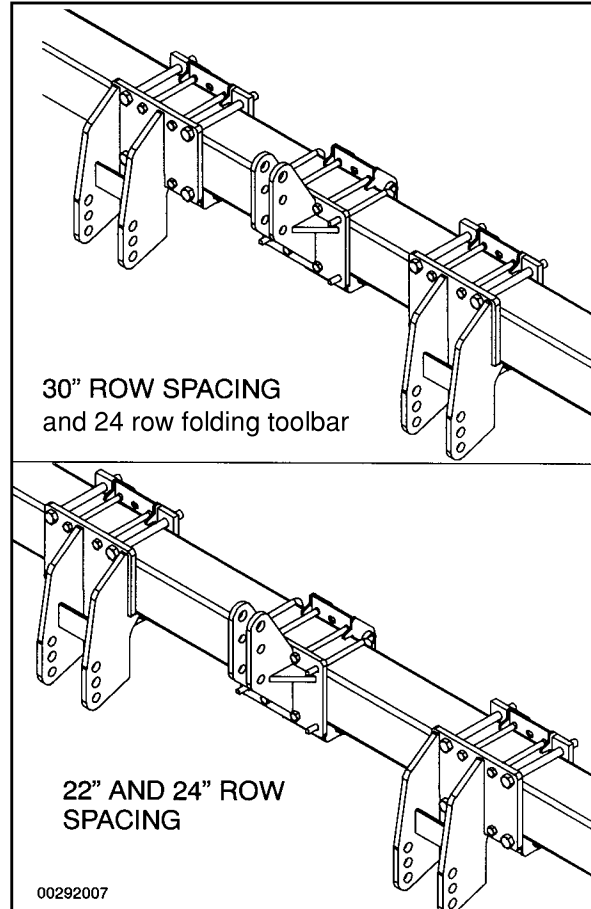

Figure 3 Hitch Mounting Positions

MOUNT HITCH (CONT'D)

Install 3-Piece Mast

1. Install upper mast, using U-bolts, lock washers, and nuts.
2. Attach center hitch to toolbar and upper mast, using 7/8 NC x 10" hex bolts, lock washers, and nuts.
3. Fasten the 1-1/4" OD bushings between the plates, using 1 x 5" hex bolts, lock washers, and nuts.
4. See Figure 4, Figure 5, or Figure 6 for the correct bushing location to fit the hitch that will be used. Be sure upper mast is centered on the toolbar.

NOTE: The short side of the wings must be on the tractor side toolbar.

IMPORTANT

■ If the cultivator is used with lift assist wheels, it must be operated as a semi-mounted unit to prevent damage to the 3-point hitch components. Remove the upper link mast and attach the cultivator to the lower 3-point hitch links only. Lift assist wheels will always carry part of the cultivator weight.

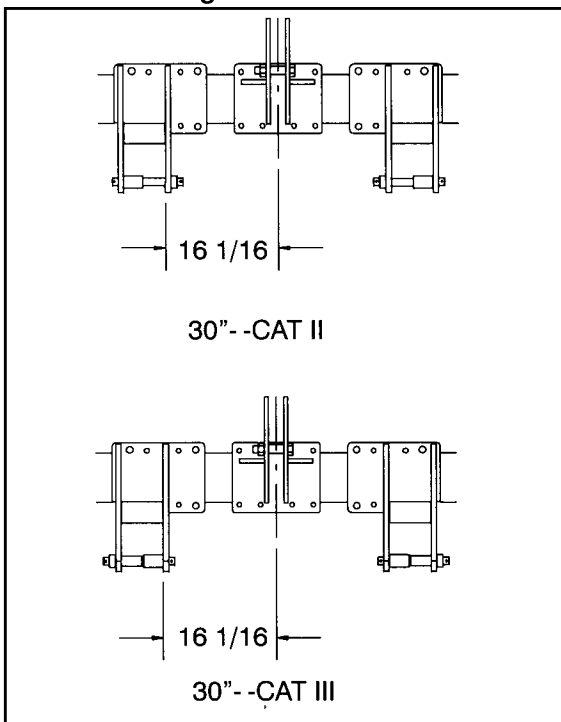

Figure 4 Hitch Position 30" Row & 22"-24" Row

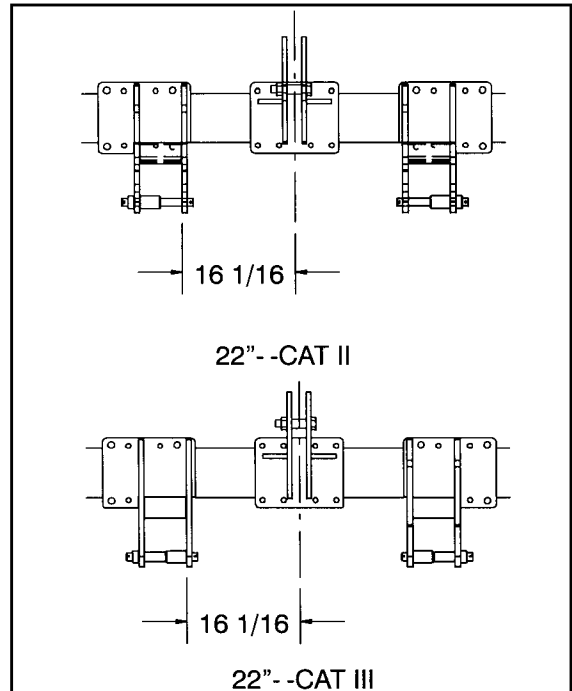

Figure 5 Hitch Position 22" Row

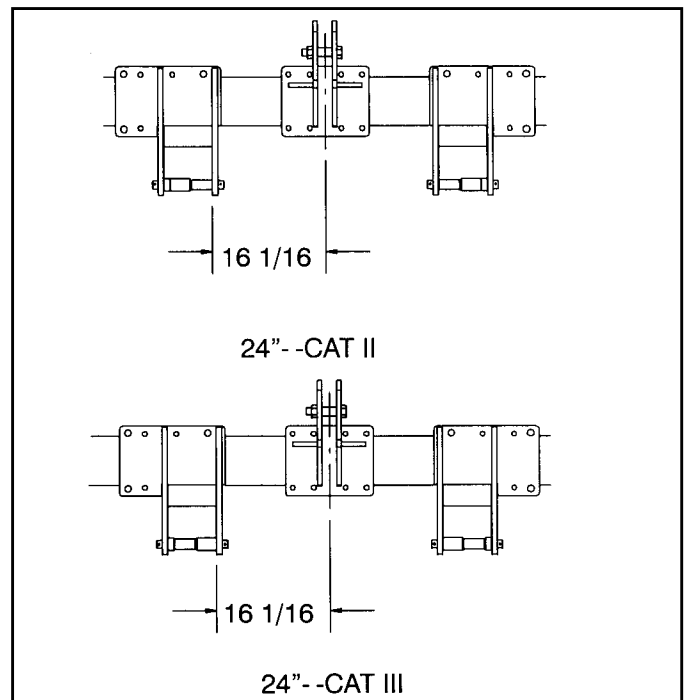

Figure 6 Hitch Position 24" Row

MOUNT HITCH (CONT'D)

Install 3-Piece Mast (Cont'd)

1. Support toolbar and fasten each lower 3-point bracket to toolbar. Install 7/8" hex bolts, lock washers, and nuts through row linkage and lower bracket.
2. Position lower 3-point brackets and spacers to match tractor hitch (Figure 4, Figure 5, or Figure 6). 24" row units use different lower 3-point brackets.

NOTE: Linkages attached to the 3-point brackets use 7/8 NC bolts and backstraps to attach the toolbar.

3. Mount spacer to lower 3-point brackets, using 1-1/8" OD x 9-5/16" pins and 7/16 x 2" Klik pin.

NOTE: Do not tighten bolts until entire cultivator is assembled.

Pull-Type Hitch

1. Wheel masts and tongue are assembled at the factory. Install wheel masts in the guide rows, usually at 44" and 88" inches from the center row unit.

2. Attach wheel mast assemblies to the front 7 x 7 tube, using 1" NC x 4.5/3" bolts, lock washer and nut.

3. Center tongue on front 7 x 7 toolbar and attach with 1" NC x 10 bolts and lock nuts.

4. Tighten bolts to specifications in the Bolt Torque Chart, page 94.

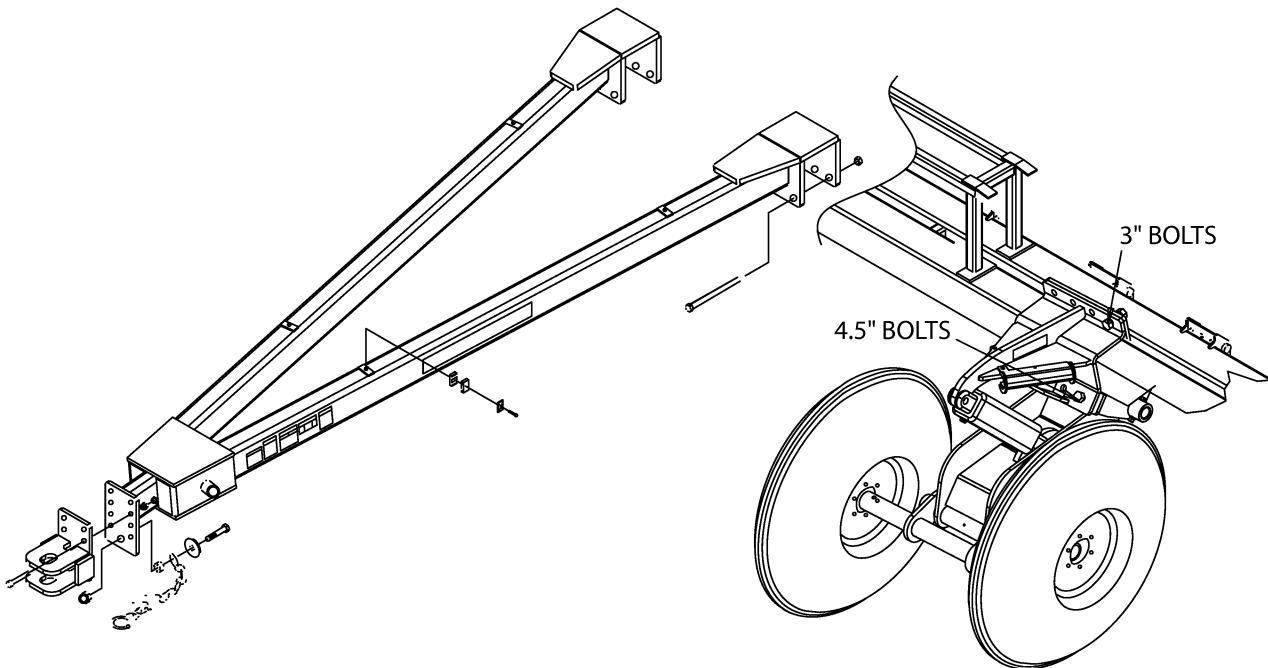

Figure 7 Pull-Type Hitch and Wheel Mast Assembly

Assembly *Cont'd*

Assemble Toolbar

1. On toolbars with 180-degree folding wings, assemble the cylinder yoke assembly when mounting the wings.

2. Use the longest pins on 7" x 7" toolbars. The ports on the cylinder should face toward the tractor side of the cultivator.

3. Secure the hinge pins with 5/16 x 2-1/2" bolts and lock nuts.

4. Assemble 3/4" jam nuts onto the 3/4" x 2-1/2" bolts and turn them into the hinge plates, located at the underside of the hinge. The bolt head faces the wings.

NOTE: On double toolbars, make sure the short side of wings are on the tractor side of the toolbar or the bolts used to level the wings will not be in the proper place.

5. Assemble grease zerks in cylinder linkage bars.

6. Mount the linkage bars to the wings, using medium-length pins. The grease zerks should point outward from the hinge.

7. Secure the linkage bar pins with 5/16" x 2-1/2" bolts and lock nuts.

8. Assemble the linkage bars to the cylinder casting, using welded head pins and snap ring pins as shown in Figure 9. The snap ring pins go through the pin on the tractor side of the cylinder.

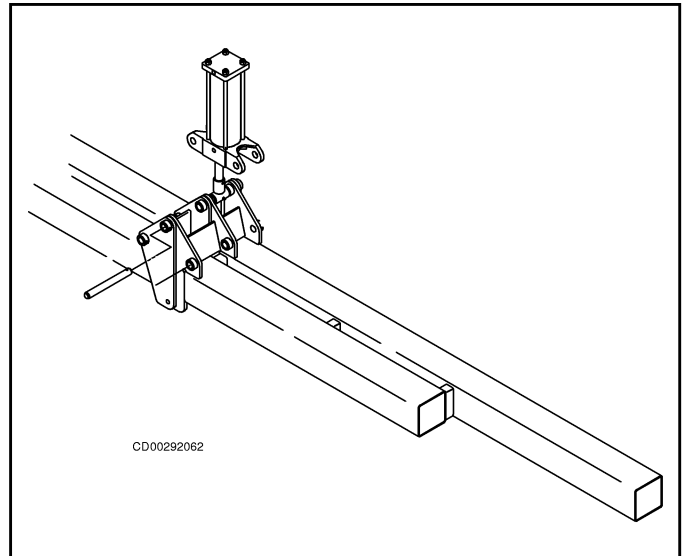

Figure 8 Mounting Wings

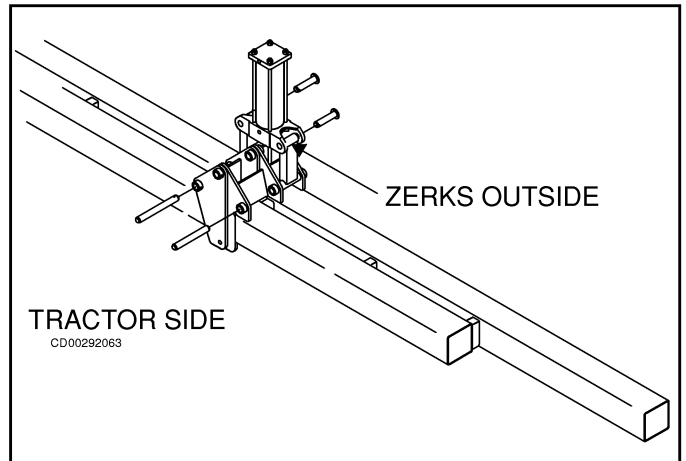

Figure 9 Mounting Cylinder Linkage Bars

Assembly *Cont'd*

Mount Hydraulics

WARNING

■ Air in hydraulic systems can cause erratic operation and allow loads or equipment components to drop unexpectedly. When connecting equipment or hoses or performing any hydraulic maintenance, purge any air in hydraulic system by operating all hydraulic functions several times. Do this before putting into service or allowing anyone to approach the equipment.

■ Make sure all hydraulic hoses, fittings, and valves are in good condition and not leaking before starting power unit or using equipment. Check and route hoses carefully to prevent damage. Hoses must not be twisted, bent sharply, kinked, frayed, pinched, or come into contact with any moving parts. Operate moveable components through full operational range to check clearances. Replace any damaged hoses immediately.

1. Fasten adapters to the cylinders.
2. Attach 90-degree elbows to adapters. Point elbows downwards and toward the center of the cultivator.
3. Fasten the long hoses to the upper ports on cylinders and medium hoses to the lower ports on cylinders.
4. Run the hoses to the center of the toolbar and fasten the two long hoses and two shorter hoses together.
5. After cultivator is completely assembled, fasten two 60" hoses to the toolbar, using the plastic cable ties.
6. Fasten the wing rests to the center section, using 5/8" U-bolts, nuts, and lock washers (not required on TRF) as shown in Figure 11. Locate wing rests by measuring from the hinge pin. Make sure there is no interference with gang assemblies when folded.
7. Install hydraulic tips and attach 3-point hitch to front of toolbar.

NOTE: Do not tighten wing rests until entire cultivator has been assembled. They may need to be moved to avoid other components bolted to the center toolbar or wings.

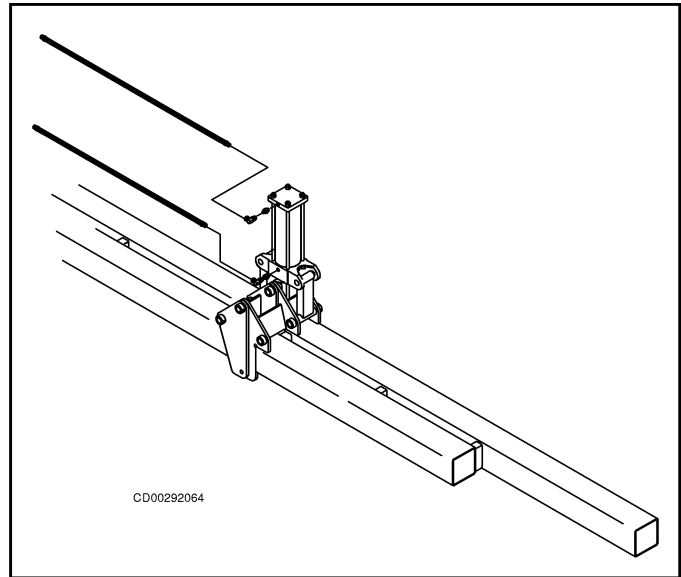

Figure 10 Installing Hydraulic Fittings

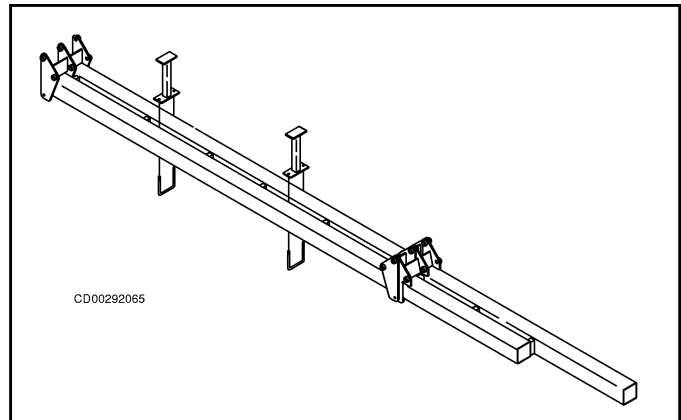

Figure 11 Wing Rest

8. Torque hydraulic fittings according to specifications given below.

TORQUE SPECIFICATIONS

Fitting	Required Torque
3/8 Flare JIC	17 - 19 lbs.-ft.
3/8 O-Ring Boss	24 - 26 lbs.-ft.
1/2 O-Ring Boss	50 - 60 lbs.-ft.

Assembly *Cont'd*

Make Final Adjustments

1. Attach to tractor and slowly fold and unfold; then make final adjustments.
2. On folding toolbars, charge the hydraulic cylinders by raising the wings 1 foot and unfolding several times to make sure hydraulic cylinders are completely filled with oil.

IMPORTANT

■ **Failure to charge hydraulic cylinders will cause damage to the cultivator and possible personal injury as wings will “free fall” into transport position. Stay clear of folding toolbars when folding.**

3. Level wings to the center toolbar, using $3/4$ x $2-1/2$ ” hex bolts and jam nuts. These may need to be readjusted after cultivator is completely assembled.

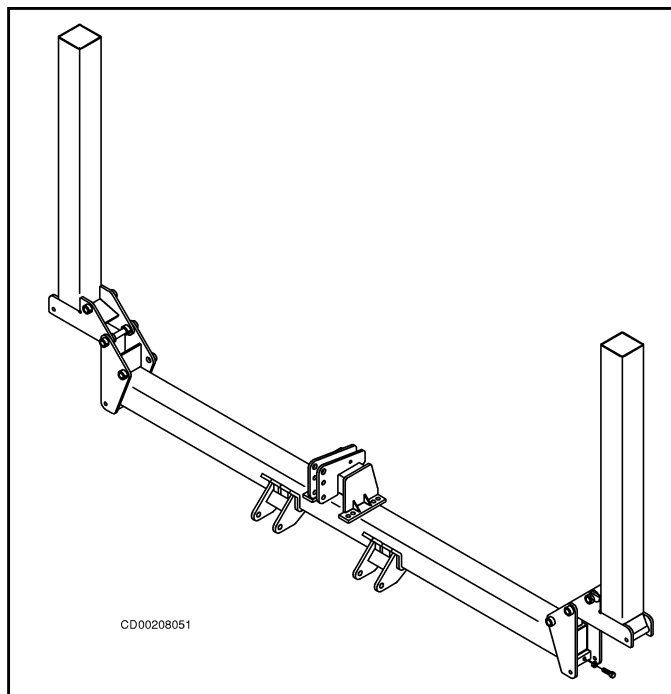

Figure 12 Leveling Wings

Assembly *Cont'd*

Install Lights

1. Rigid Bar (TRR): Install light brackets to ends of toolbar, using U-bolts and nuts as shown in Figure 13.

1. Folding Bar (TRR and TRF): Install light brackets to wing support plates, using 5/8" bolts and nuts.

2. Attach tail light assemblies to brackets. Tail lights should be mounted toward the outside of the cultivator with red lens visible to the rear and towards the bottom.

3. Connect the light harness to the tail lights and secure to top side of toolbar, using plastic ties. When cultivator is completely assembled, use additional tie straps to secure harness in place.

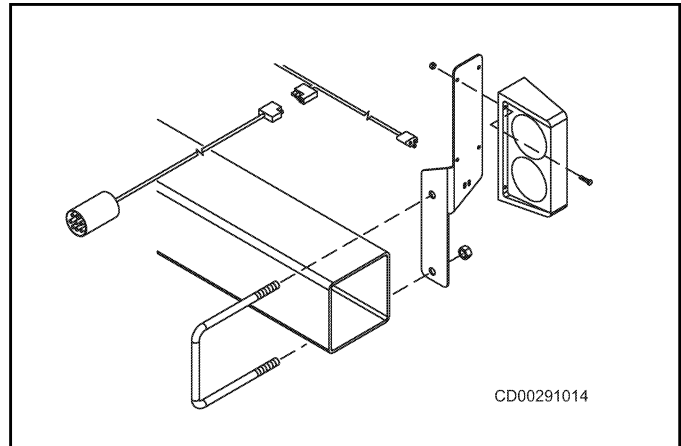

Figure 13 Installing Lights
(Rigid bar shown)

IMPORTANT

■ **Tail light harness must be installed so that it is not pinched or damaged during operation of the cultivator.**

4. Connect tractor harness to tail light harness and secure out of the way during rest of assembly.

5. Fasten end cap, using screw provided.

Mount Row Units

1. Locate the center of the toolbar and mark it. Mark off the row spacings on both sides of the center mark.

Example: On even row units (8 or 12 rows), if the cultivator will be used for 30-inch rows, mark off every 30 inches on both sides of the center mark.

2. Center the linkage assemblies over the marks made on the toolbar and fasten them, using 5/8" U-bolts and flanged nuts.

NOTE: Linkages attached to the 3-point brackets use 5/8 NC bolts and the linkage.

3. Install row units with 6 x 12. Set back gauge wheel at 44" or 88" from center if using steel or semi-pneumatic guide wheels.

Assembly *Cont'd*

Mount Tines

Straight Edge Tine

1. Fasten tine to tine pitch bracket, using 1/2 x 1-1/2" hex bolt and flange nut.

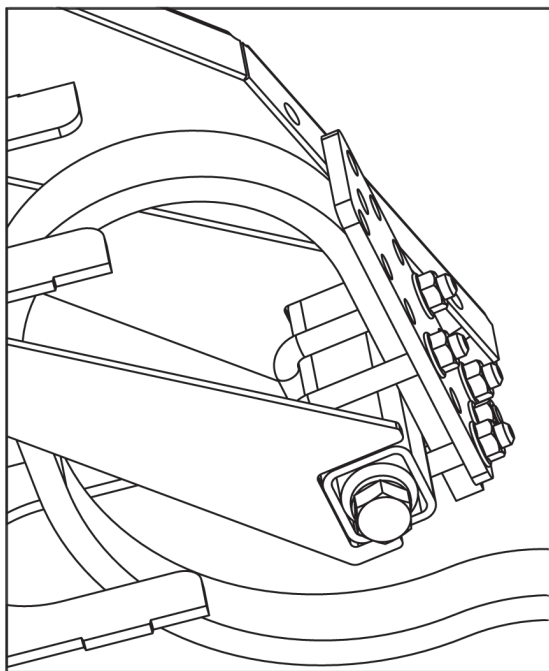

Detail

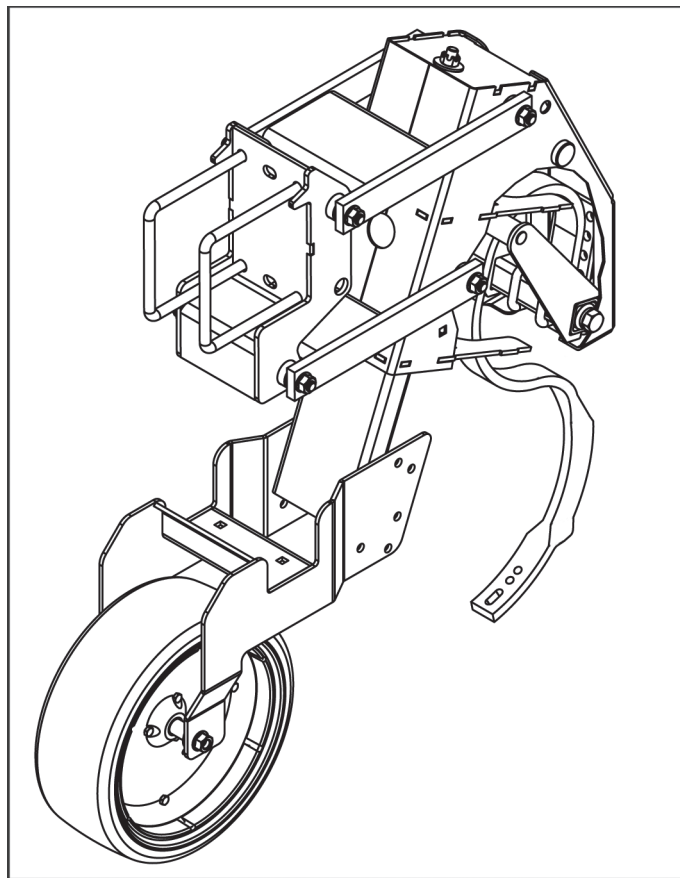

Figure 14 Mounting Straight Edge Tine

Assembly *Cont'd*

Mount Shovels & Sweeps

Heavy Duty Adjustable Tine

1. Fasten shovels to tine, using two 7/16 x 2" plow bolts with 1/2" heads, flat washers, lock washers, and hex nuts as shown in Figure 15.
2. Adjust shovel pitch by selecting top or bottom holes in tine.

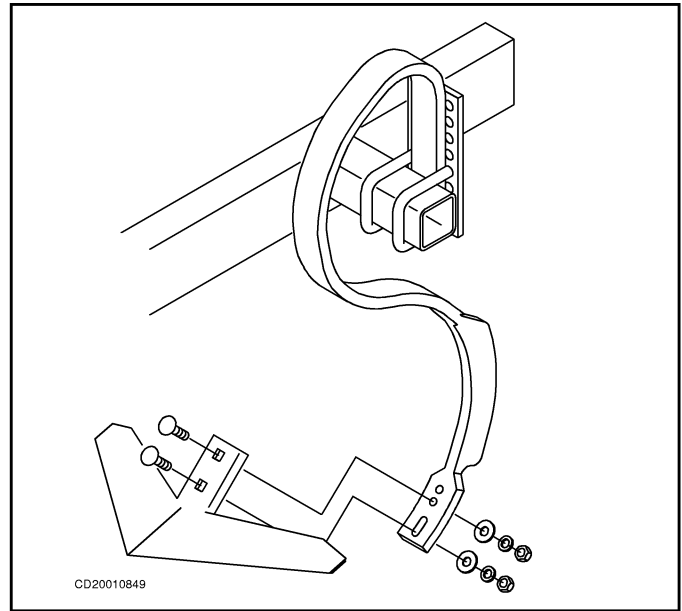

Figure 15 Straight Edge Tine

Rear Shank

1. Fasten shovels to shank, using two 1/2 x 3" plow bolts, flat washers, lock washers, and hex nuts.

Large sweeps use 1/2 x 3-1/2" plow bolts and spacer plates as shown in Figure 16.

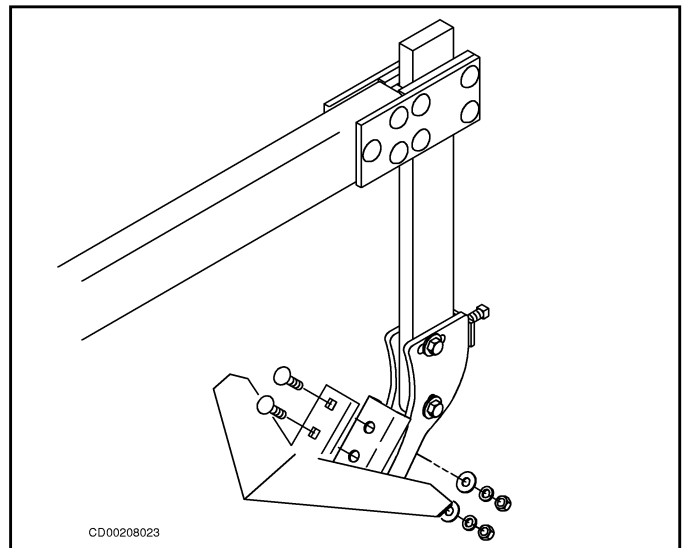

Figure 16 Rear Shank

Assembly *Cont'd*

Mount King Guide Struts, Shanks, & Extensions

1. Fasten king guide strut to the toolbar, using 7/8" A-bolts, lock washers, and hex nuts as shown in Figure 17.
2. Attach shanks to king guide strut, using 1/2 NC x 1-1/2 bolt and flanged lock nut (Figure 18).
3. Attach extensions to the king guide struts (Figure 19).

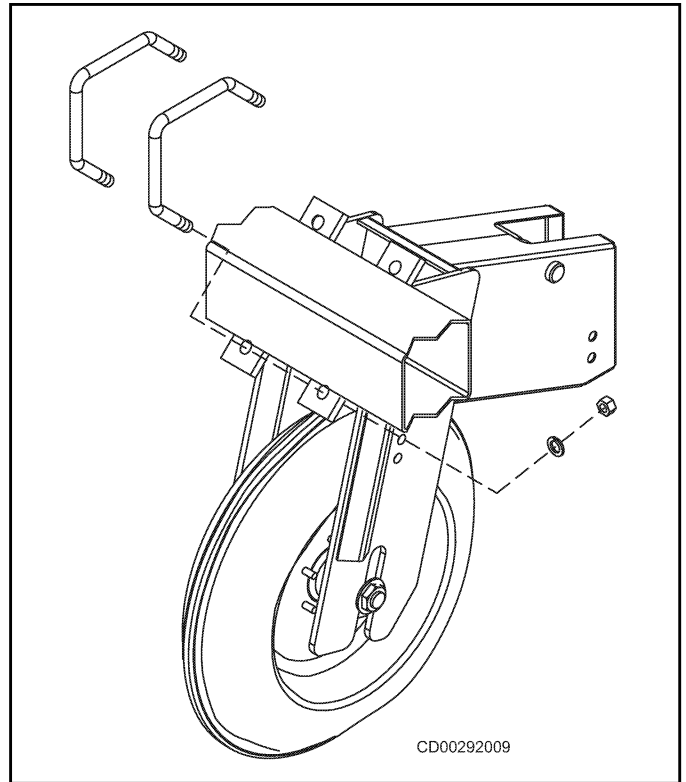

Figure 17 Mounting King Guide Strut

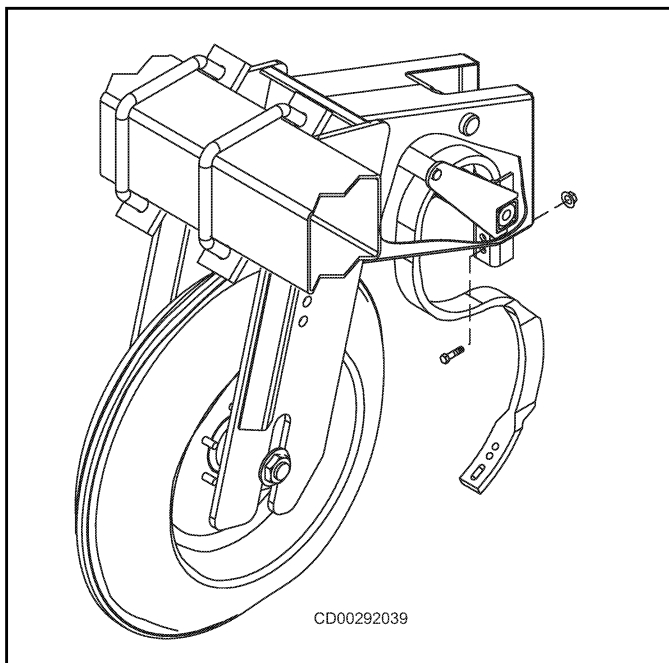

Figure 18 King Guide Adjustable Shank

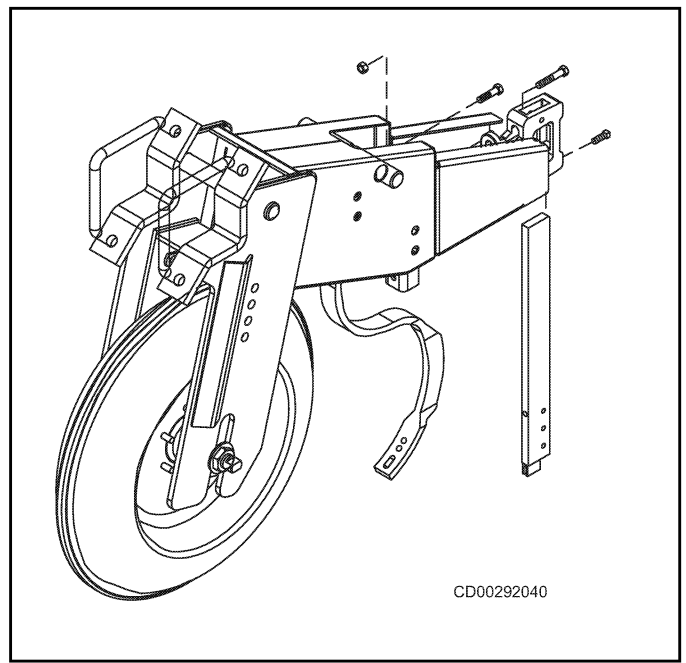

Figure 19 King Guide Shank Extension

Assembly *Cont'd*

Install Down Pressure Springs

1. Insert spring rod in mounting bracket and install cotter pins.
2. Replace picot bolt retaining nut with new shoulder nut provided.
3. Slide spring into place over spring rod and fasten into place with spring retainers. Use flat washers on each side of spring hook as shown in Figure 20.

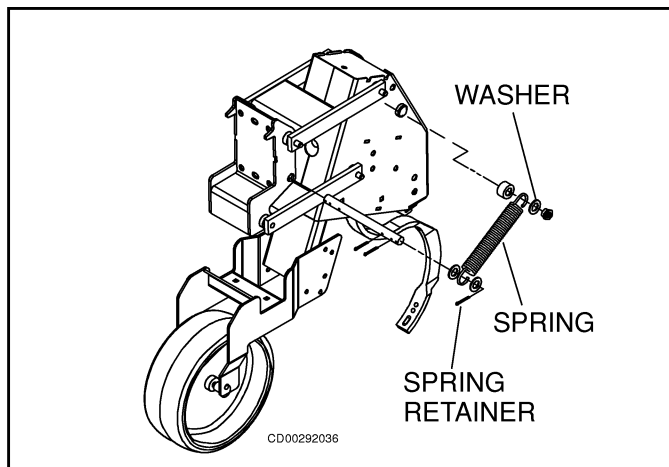

Figure 20 Down Pressure Springs

Assembly *Cont'd*

Rear Extension with Hiller or Rigid Shank

1. Attach rear extension to linkage, using four cap screws, lock washers, and nuts on each unit.

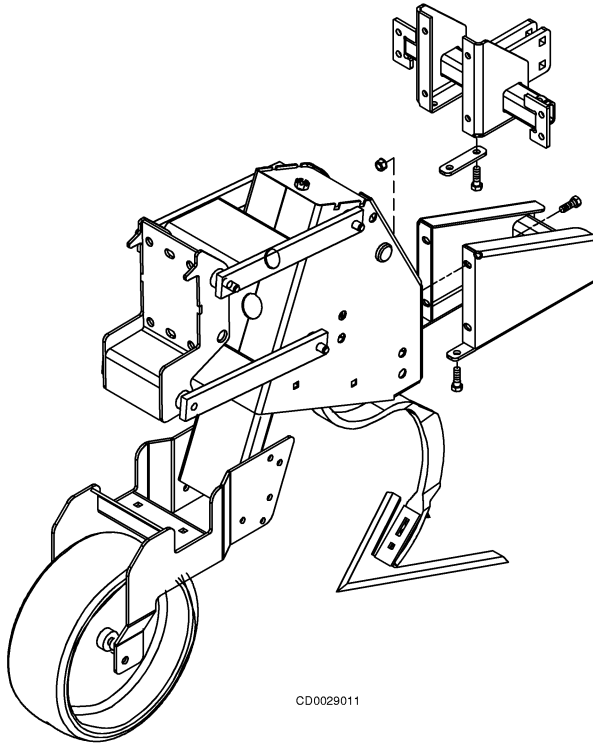

Figure 21

Rear Extension with Cast Clamp

1. Attach cast clamp body to rear extension and attach shank to clamp.

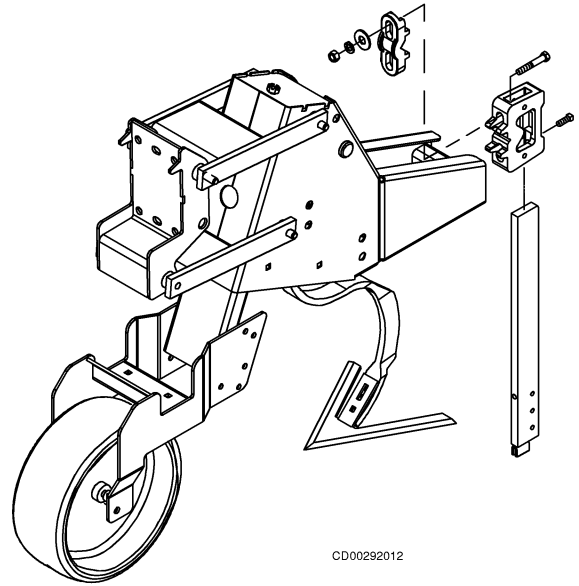

Figure 22

Rigid Rear Extension with Shank

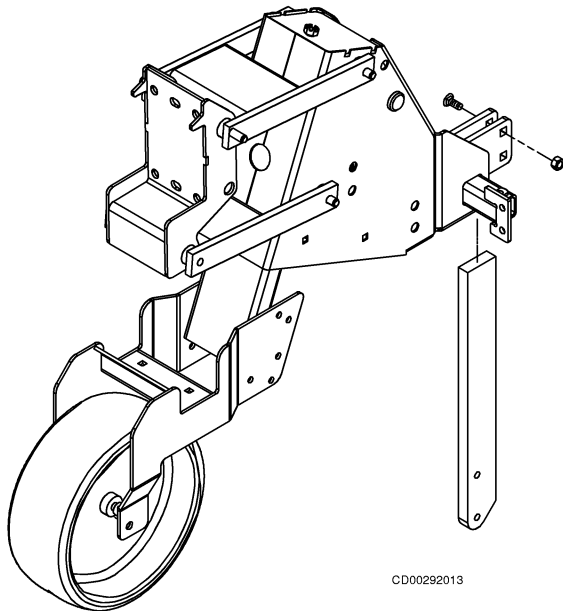

Figure 23

Rigid Rear Extensions with Tine Adapter

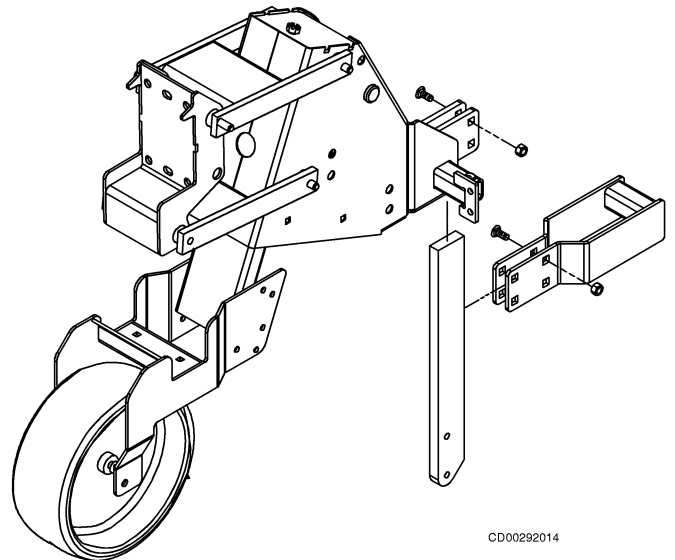

Figure 24

Assembly Cont'd

Mount Coultter Discs

Straight Edge Tines

1. Fasten hub assembly to disc, using 3/8 x 1-1/4" hex bolts, lock washers, and hex nuts as shown in Figure 26.
2. Mount disc/hub assembly to disc mount arms, using 3/8 NC x 1-1/2 hex head cap screw as shown in Figure 27.
3. Attach disc arms with 1/2 NC carriage bolts, spacer, washer, and adjustment pin.
4. Lock bearing lock collars in direction of wheel travel (see Figure 25).

Rigid Tines

1. Fasten hub assembly to disc, using 3/8 x 1-1/4" hex bolts, lock washers, and hex nuts as shown in Figure 26.
2. Mount disc/hub assembly to disc mount weldment, using 3/8 NC x 1-1/2 hex head cap screw as shown in Figure 25.
3. Attach disc arms with 1/2 x 1-1/2 bolts, spacer, washer, and adjustment pin.
4. Lock bearing lock collars in direction of wheel travel (see Figure 25).

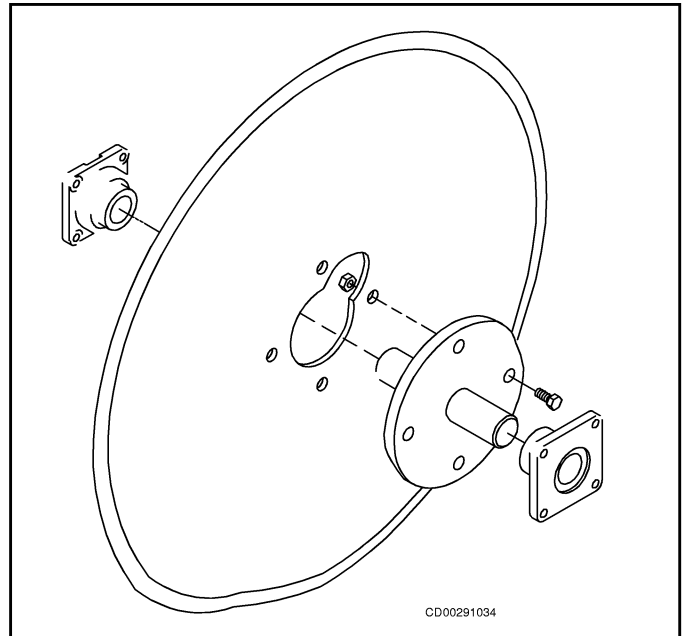

Figure 26 Mounting Coultter Disc

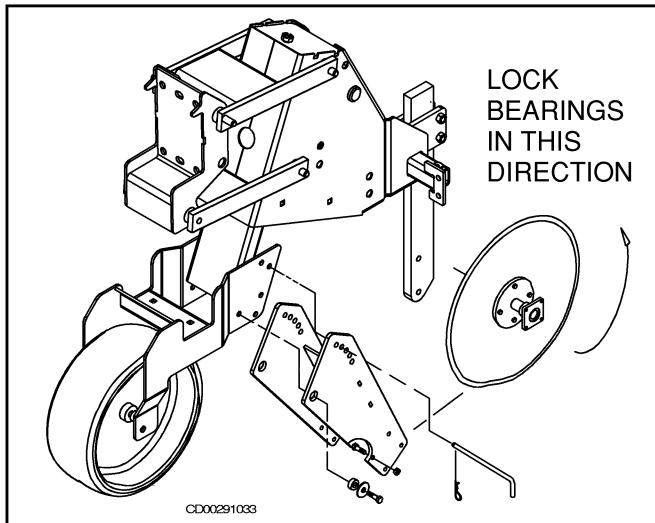

Figure 25 Disc Mount Assembly
(Rigid shank tine)

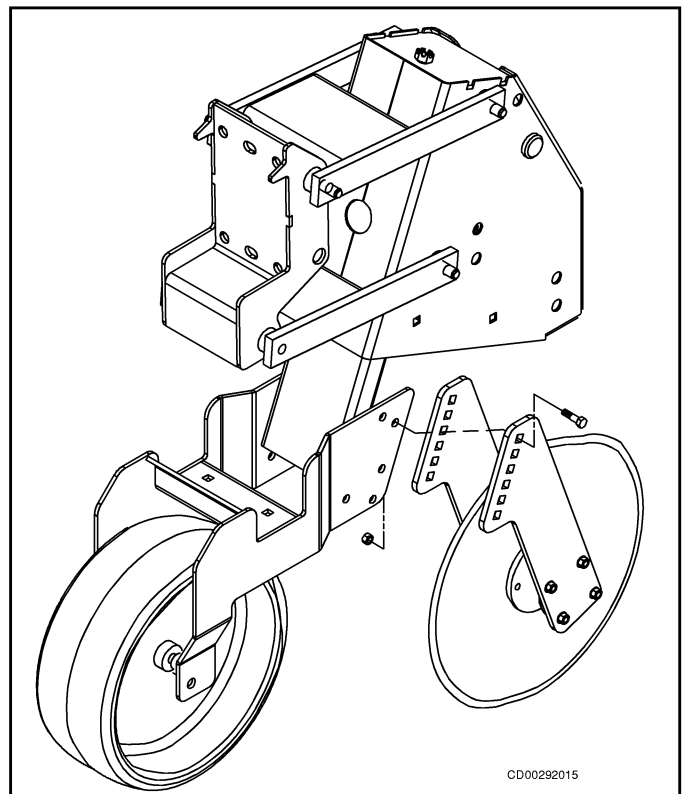

Figure 27 Disc Mount Assembly
(Straight edge tine)

Assembly *Cont'd*

Attaching Adjustable Support Wheels

Mount Pivot Arm

1. Attach pivot arm, using pin and two 5/16 x 1-5/8" roll pins as shown in Figure 28.

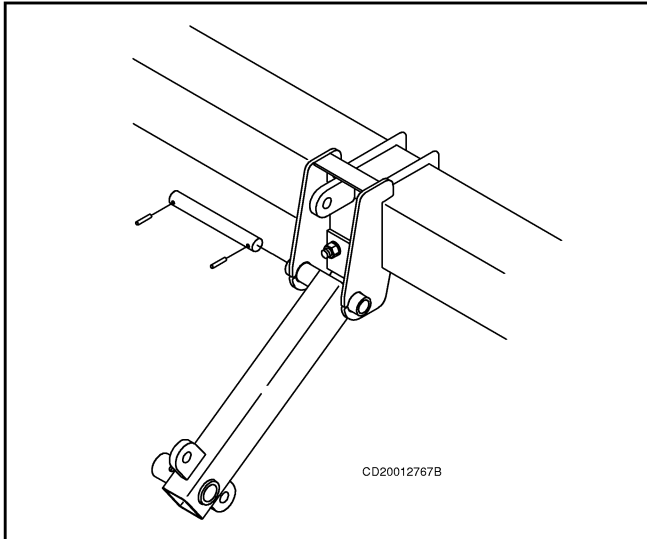

Figure 28 Mounting Pivot Arm

Attach Screwjack

2. Attach screwjack, using two 1 x 3" hex bolts, lock washers, and hex nuts as shown in Figure 29.

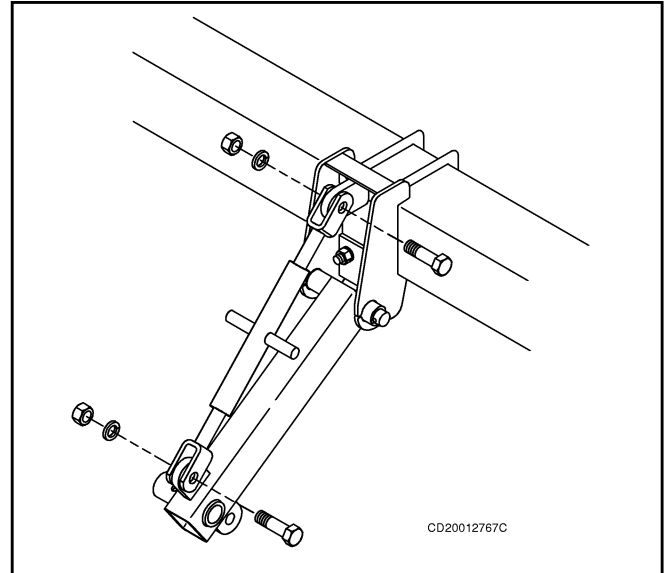

Figure 29 Attaching Screwjack

Fasten Hub & Spindle Assembly

3. Fasten hub and spindle assembly, using 1/2 x 3" hex bolt, lock washer, and hex nut as shown in Figure 30.

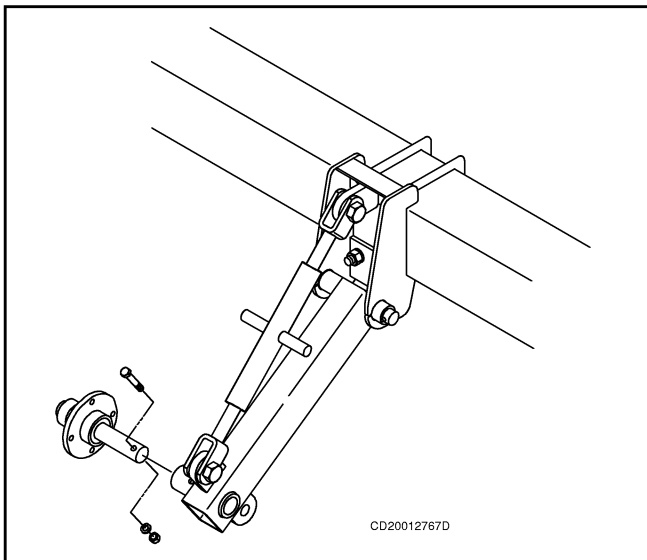

Figure 30 Fastening Hub & Spindle Assembly

Fasten Tire & Rim Assembly

4. Fasten tire and rim assembly, using bolts provided in hub as shown in Figure 31.

5. If you have a support wheel, be sure tire is centered over the guide marks; then tighten U-bolts on mount.

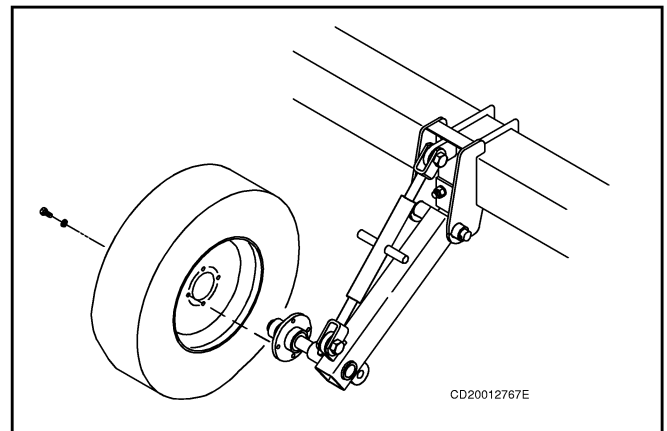

Figure 31 Fastening Tire & Rim Assembly

Mounting Semi-Pneumatic & Steel Guide Wheels

Mount Guide Wheels

1. Mount guide wheels centered over guide marks, using U-bolts provided as shown in Figure 32.

NOTE: For some applications, these wheels may need to be mounted behind the tractor tires.

IMPORTANT

- When using semi-pneumatic or steel guide wheels, measure tractor and cultivator carefully. Position wheels so that they will not hit tractor cab when toolbar is folded.
- When placing behind tractor tires, carefully check the clearance in all positions. Some tractors without quick hitch may not have adequate clearance when the cultivator is raised.
- Adjustable gauge wheels will interfere with semi-pneumatic or steel guide wheels and may not be used together.

2. Adjust wheels by removing bolt in angle and turning adjustment plate as shown in Figure 33.

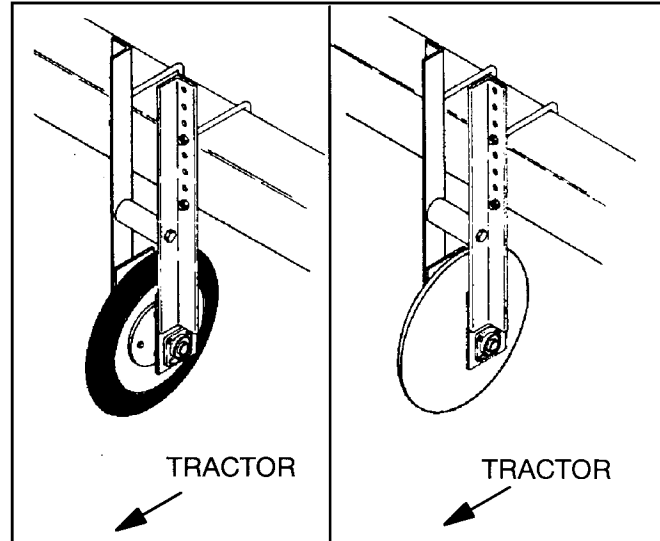

Figure 32 Semi-Pneumatic Wheels (left) & Steel Guide Wheels (right)

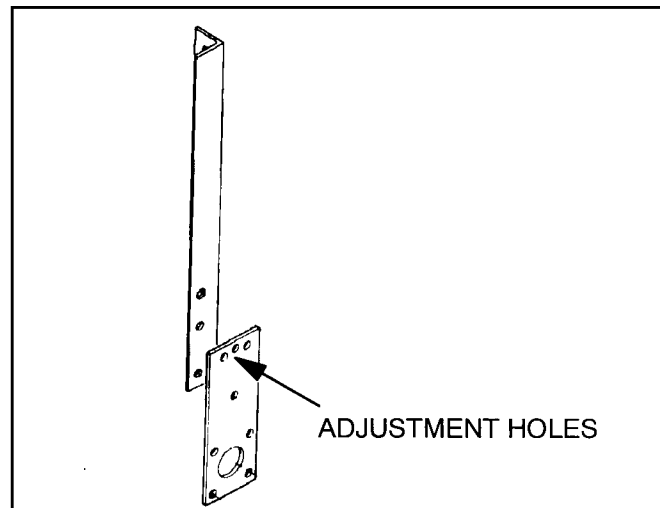

Figure 33 Adjustment Plate

Mount Front Parking Stands

Two front parking stands are included with all 3130 cultivators.

1. Install front parking stands at each end of the toolbar center section as shown in Figure 34.

2. **TRR and F toolbars:** Position parking stand assembly between row units and fasten to front side of toolbar as shown in Figure 35, using 5/8" U-bolts and flanged nuts.

2. **TRF toolbars:** Attach front parking stands to short hinge tubes of reinforced folding toolbars as shown in Figure 35, using 5/8" U-bolts and flanged nuts.

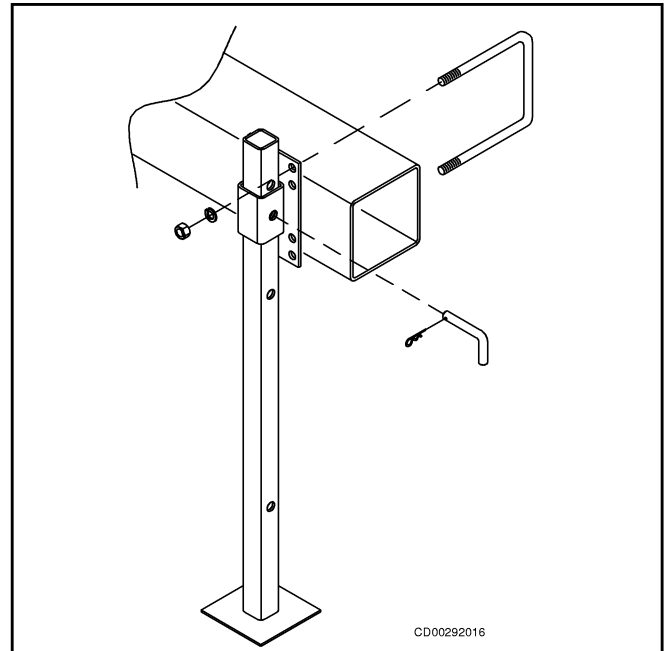

Figure 34 Mounting Parking Stand

Rear Parking Stands

Rear parking stands are included with all folding toolbar cultivators (TRF and F). Rear parking stands must be used for all folding toolbar cultivators not equipped with lift assist wheels.

1. Install parking stands at each end of the toolbar center section as shown in Figure 35.

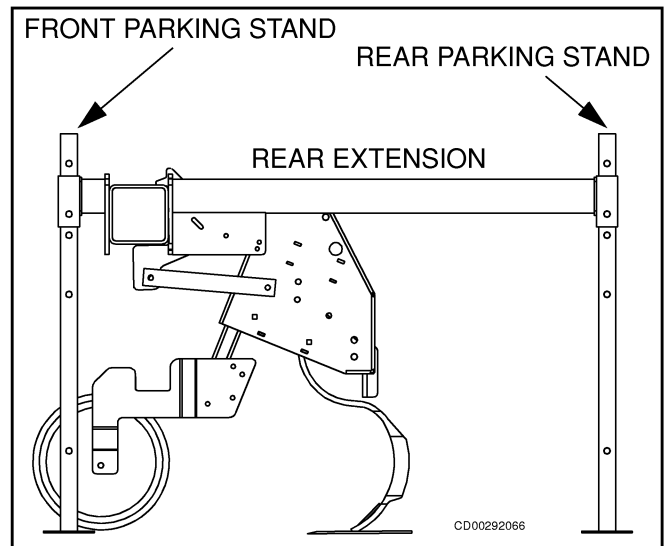

Figure 35 Front and Rear Parking Stands
(Type F toolbar)

Mounting Adjustable Support Wheels

WARNING

- Before folding or unfolding cultivator:
 - Make sure you have adequate clearance on each side and overhead.
 - Make sure wing cylinder restrictor fittings are properly installed.
 - Make sure wing-mounted gauge wheels and guide coulters will not contact tractor cab or tires.

Measure Support Wheel Location (Figure 36)

Support wheels may need to be adjusted to prevent interference with some tractor cabs or accessories when folding and unfolding the cultivator.

Reposition support wheels following these steps:

1. Measure and record distance **A** from wing hinge pin to the tractor obstruction (operator cab, etc.).
2. Measure and mark the same distance from hinge pin to a point on wing **B**. Support wheels may be positioned on cultivator wings inside that point.
3. DO NOT position support wheels beyond this point, as shown in shaded area in Figure 36.

Fasten Strut Mount

1. Fasten strut mount, using two 3/4" U-bolts, lock washers, and hex nuts as shown in Figure 37.
2. **NOTE:** Mount support wheels over a linkage facing towards the tractor. DO NOT tighten the U-bolts until assembly is complete.

IMPORTANT

- These wheels may not be used behind tractor tires.
- When using adjustable support wheels, measure tractor and cultivator carefully. Position support wheels so that they will not hit tractor cab when toolbar is folded.

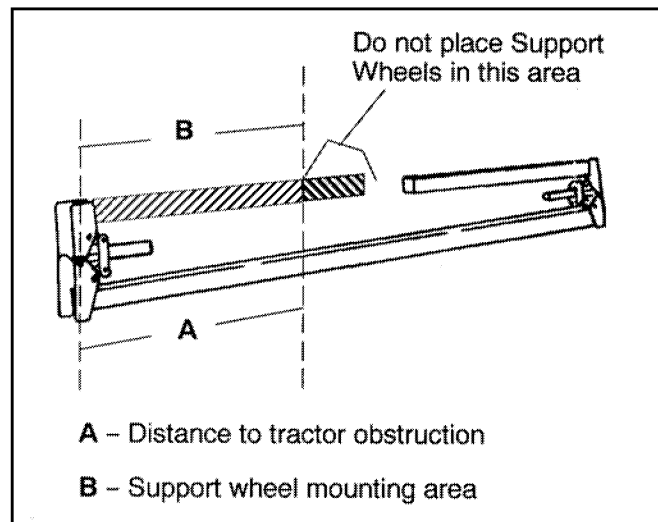

Figure 36 Measuring for Support Wheels

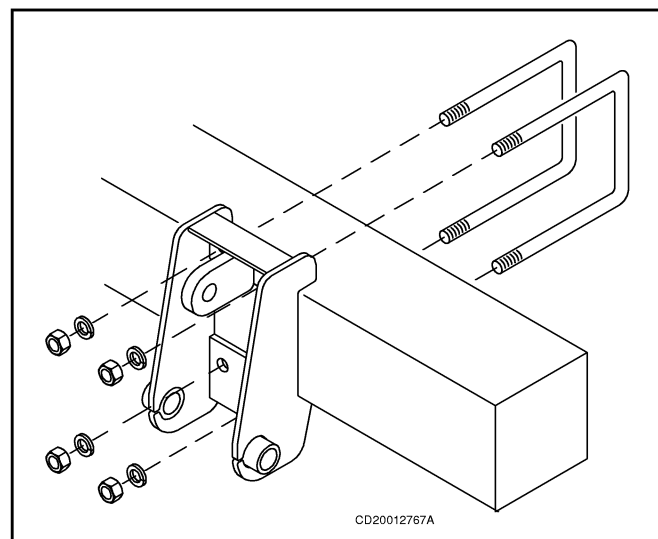

Figure 37 Fastening Strut Mount

Assembly *Cont'd*

Install Rolling Shields

Toolbar Mounted

1. Fasten mount to toolbar, using 5/8" U-bolt and flanged nuts as shown in Figure 38. Be sure mounts are centered over the row.

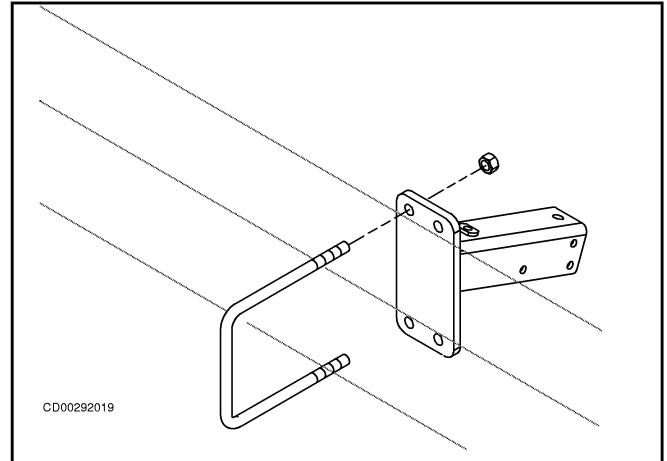

Figure 38 Toolbar Mounted Rolling Shield

Row Unit Mounted

1. Fasten mounting tubes to each side of row unit, using one 5/8 x 1-1/4 hex bolt and two 1/2 x 1 carriage bolts per side as shown in Figure 39.

2. Assemble pivot bracket on tube, set to match row spacing, and tighten set screw.

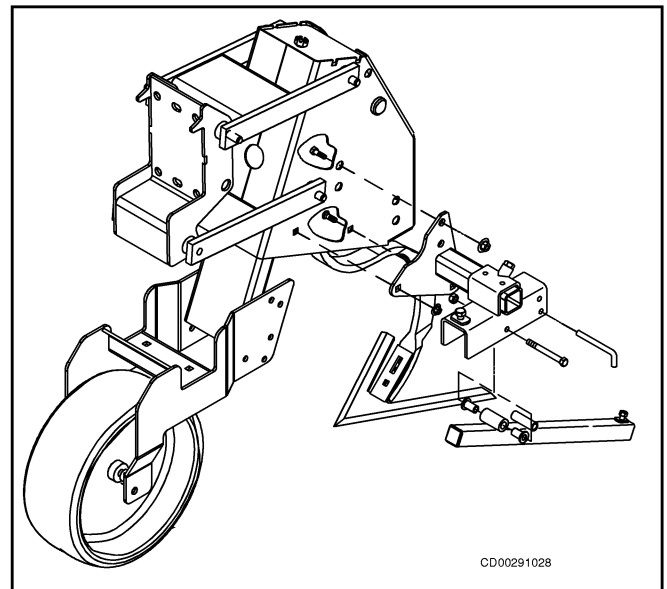

Figure 39 Row Unit Mounted Rolling Shield

Assembly *Cont'd*

Install Rolling Shields (Cont'd)

Attach Lower Tubes & Shield

1. Slide lower tube into upper tube and fasten, using bolt on upper tube.
2. Remove nut and lock washer from spindle bolt assembly.
3. Slide spacer plates and shields onto spindle assembly and fasten, using lock washers and nuts.
4. For narrow shields, place spacers on spindle assembly to outside of support plates.

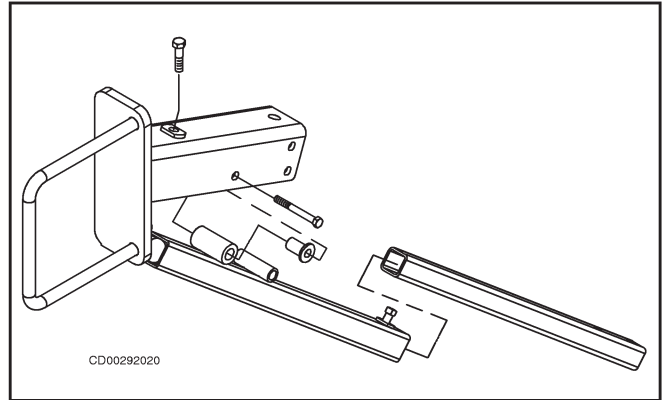
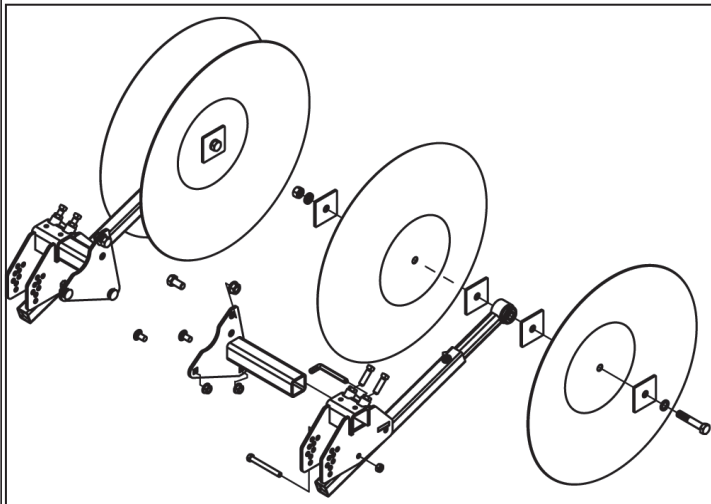
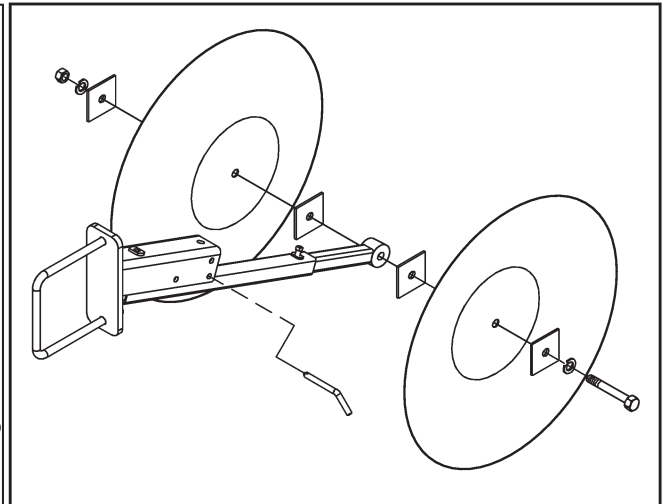

Figure 40 Fastening Tubes



Gang Mount



Toolbar Mount

Figure 41 Fastening Tubes & Shields

Assembly *Cont'd*

Open Top Shield

Fasten Mount Assembly

Shield must be used with set-back brackets as follows:

BRACKET	ROW
20022012	40"
20021950	30"
20022011	22"

NOTE: Long side of shield must point away from tractor.

1. Slide pivot bracket into set-back.
2. Install lock pin and U-bolt as shown in Figure 42.
3. Fasten end shields as shown in Figure 43.

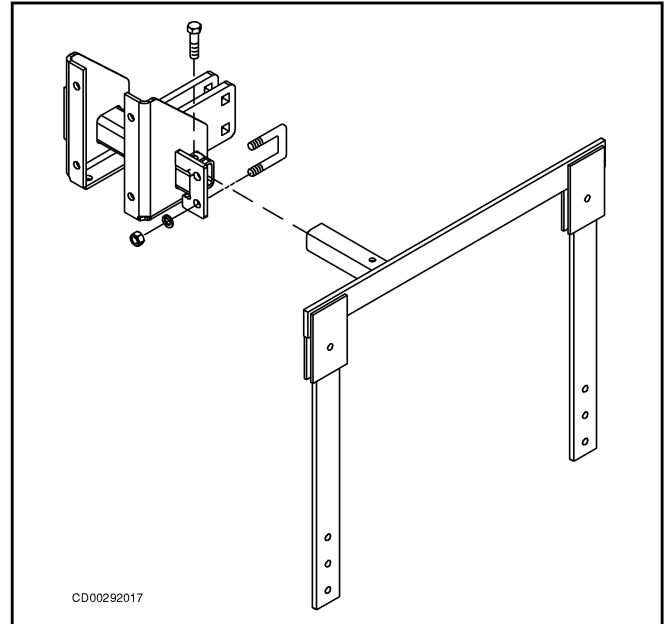

Figure 42 Fastening Mount Assembly

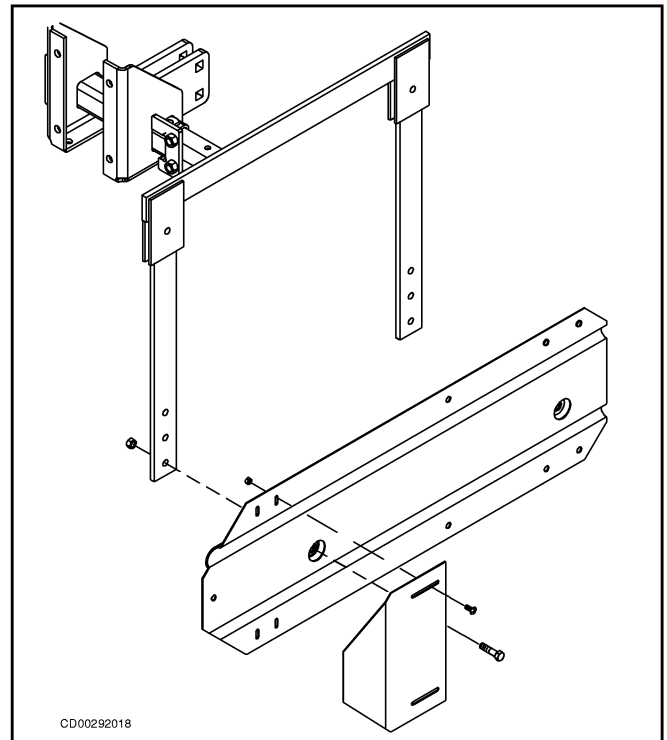

Figure 43 Fastening End Shields

Assembly Cont'd

Open Top Shield (Cont'd)

Assemble Shields

1. Fasten parallel arms to shields, using 7/16 x 1-1/4" hex bolts on back arm and 7/16 x 2" hex bolts on front arm with flat washers and lock nuts.
2. Fasten pivot bracket to parallel arms, using 7/16 x 1-1/4" hex bolts and lock nuts.
3. Attach chain to 7/16 x 2" hex bolt on front parallel arm, using lock nut.
4. Run chain to pivot bracket, fastening with 3/8 x 2-3/4" clevis pin, 5/16" flat washer, and hair pin cotter.

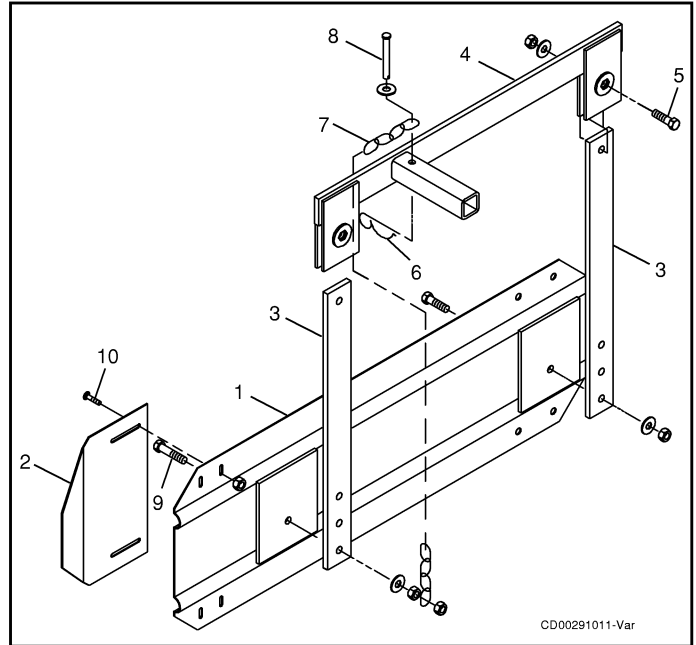

Figure 44 Assembling Shields

Attach Shield Guides

1. Attach shield guides, using 1/4 NC x 1" carriage bolts and hex nuts as shown in Figure 45.

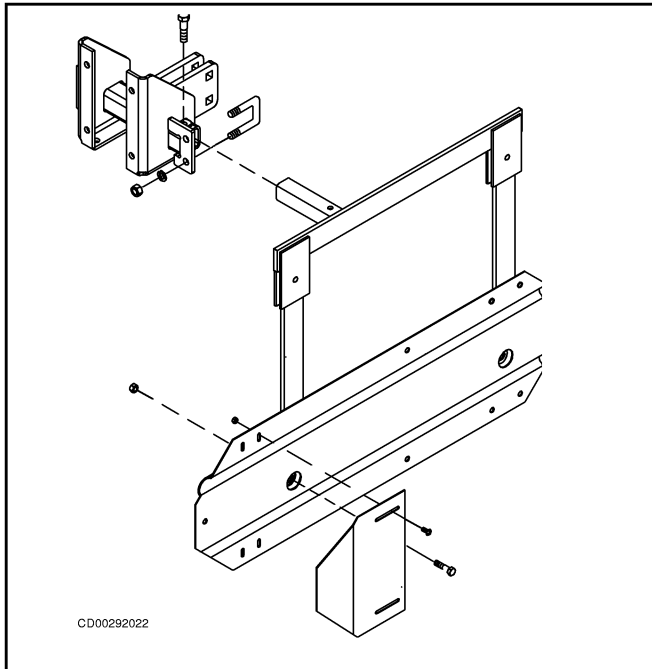

Figure 45 Attaching Shields

Attach Rear Extension

1. Fasten rear extension to shield, using 3/8 x 1" hex bolts, flat washers, and flanged nuts.

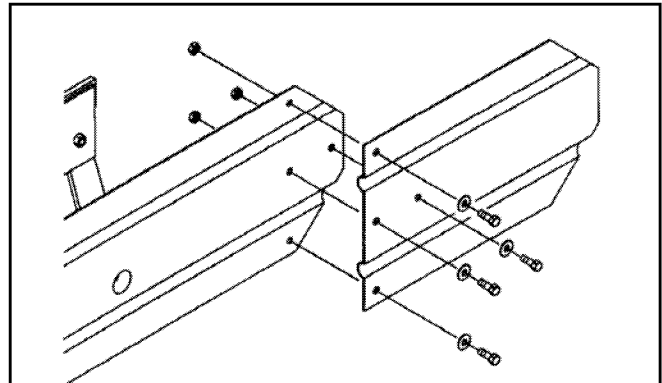

Figure 46 Attaching Rear Extension

Assembly Cont'd

Dual Disc / Dual Knife

Fasten Flip-Up Disc Tube

1. Fasten tube assembly to front tube bracket, using front tube clamp, 7/16 x 1-1/2" carriage bolts, lock washers, and hex nuts.

NOTE: Make sure tube is centered and spring assembly is on top. Spring assembly should always be on left side of tree as shown in Figure 47.

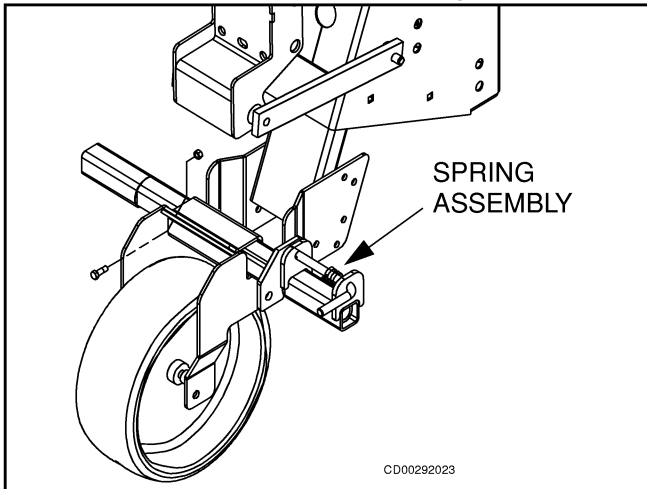

Figure 47 Flip-up Disc Tube

Fasten Clamp Assembly

1. Fasten clamp assembly to front tube, using the hardware provided with clamp assembly.

2. Mount clamps on the back side of front tube as shown in Figure 48.

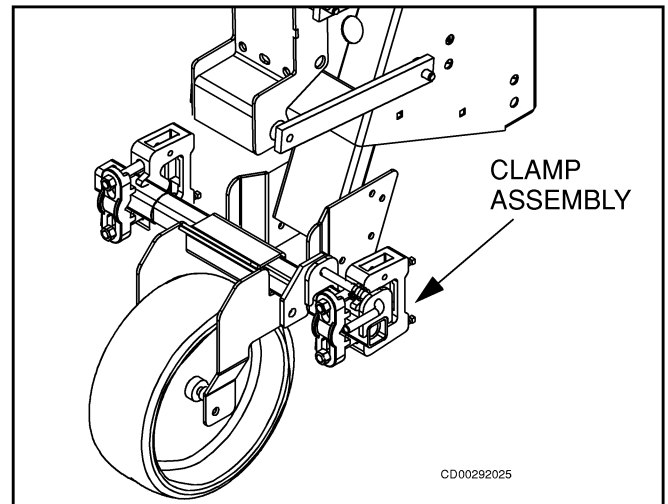

Figure 48 Fastening Clamp

Attach Shank Weldment

1. Slide shank weldment into clamp assembly, as shown in Figure 49.

2. Adjust shank to proper height and tighten set screws in clamp assembly.

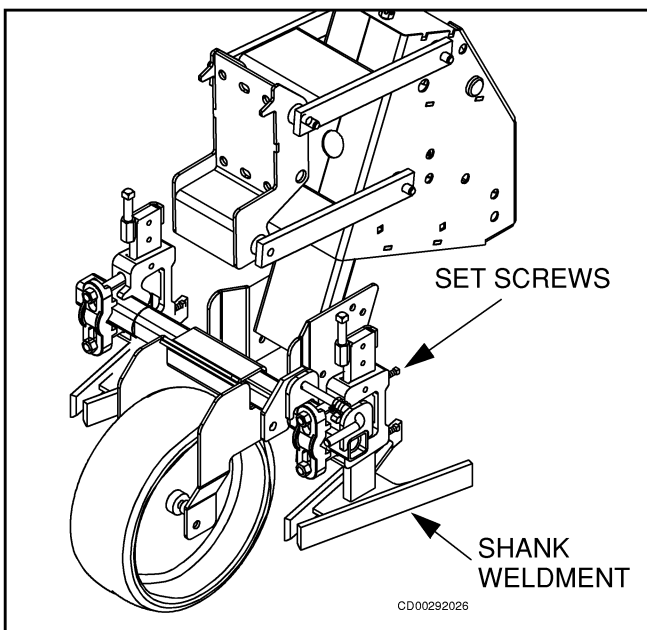

Figure 49 Attaching Shank Weldment

Fasten Dual-Disc Assembly

1. Slide dual disc assemblies over the rail on the shank weldment as shown in Figure 50.

2. Adjust to proper width and tighten hex bolt and jam nut on top of disc assembly.

NOTE: There are right and left disc assemblies. When mounted, the back of the disc should be farther away from the rail than the front to throw dirt away from the row.

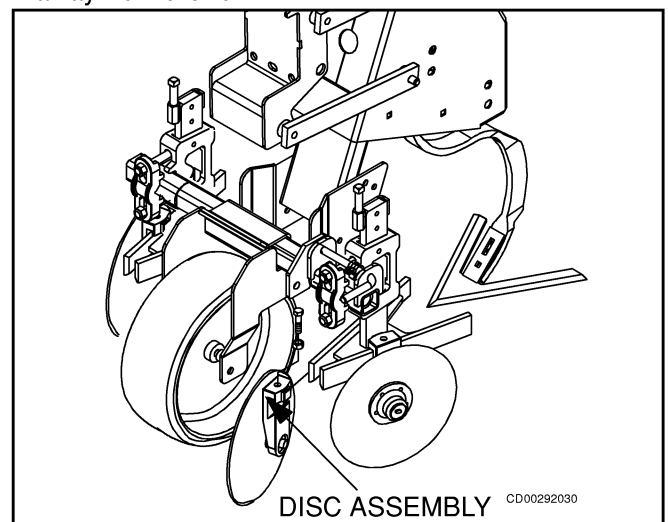

Figure 50 Fastening Disc Assembly

Assembly *Cont'd*

Dual Disc / Dual Knife (Cont'd)

Attach Dual Knife

1. Fasten the knife to the adapter, using two 3/8 x 1-1/2" carriage bolts, flat washers, lock washers, and hex nuts as shown in Figure 51. Knife must go on inside of adapter.

2. Slide dual knife assemblies over the rail on shank weldment and fasten with 1/2" hex bolt and jam nut.

NOTE: The mounting surface on the left and right knife adapters must be parallel to the row.

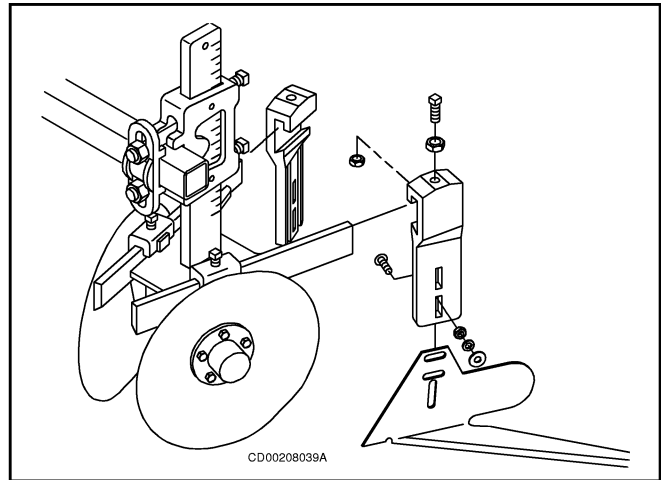

Figure 51 Dual Knife Assembly

Attach Adjustable Screw Kit

1. Fasten adjustment nut to the shank weldment, using a 3/8 x 1-1/2" hex bolt and flanged nut.

2. Thread the 5/8 x 4-1/2" square head set screw or crank into the adjustment nut as shown in Figure 52.

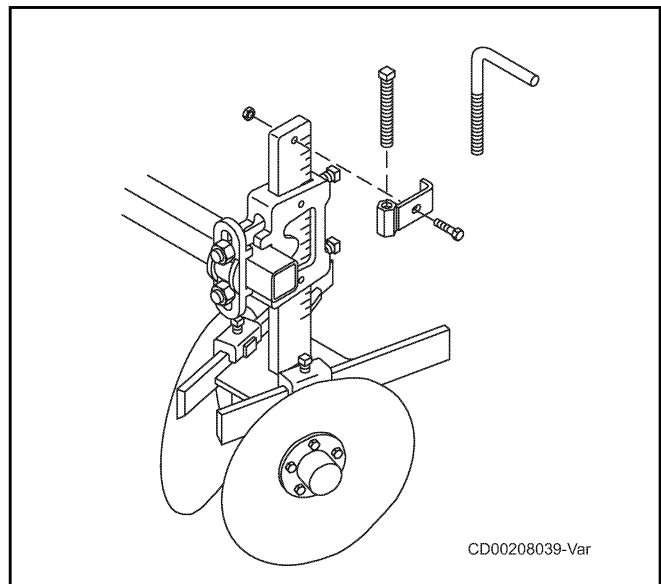

Figure 52 Adjustable Screw Kit

Assembly *Cont'd*

Row Weeder Discs

Row weeder discs are typically used to remove weeds next to the row. They can be reversed to move direct to the row.

Fasten Clamps to Tubes

1. Place front tubes in the mast as shown in Figure 53.

Assemble clamps and attach loosely to tubes as shown in Figure 54. Fasten with 1/2 NC x 3-1/2" bolts and flanged nuts.

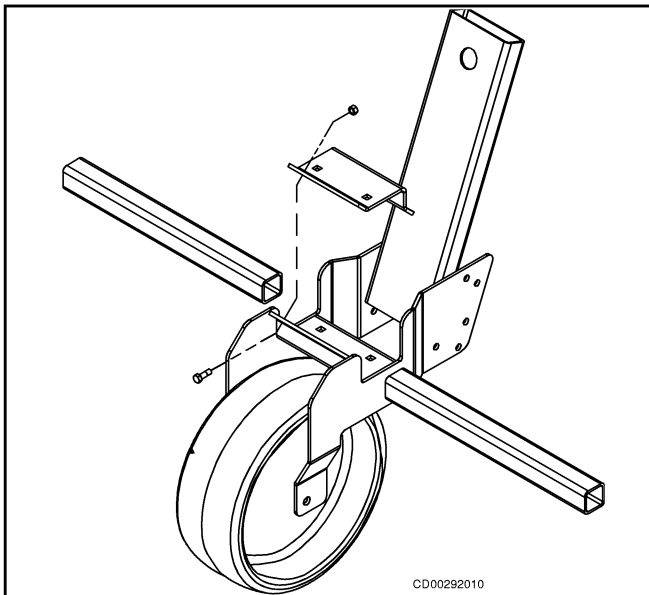

Figure 53 Front Tubes in Mast

Fasten Disc Assemblies to Tubes

1. Fasten shank and disc assembly to clamps.
2. Install set screw and jam nut as shown in Figure 55.

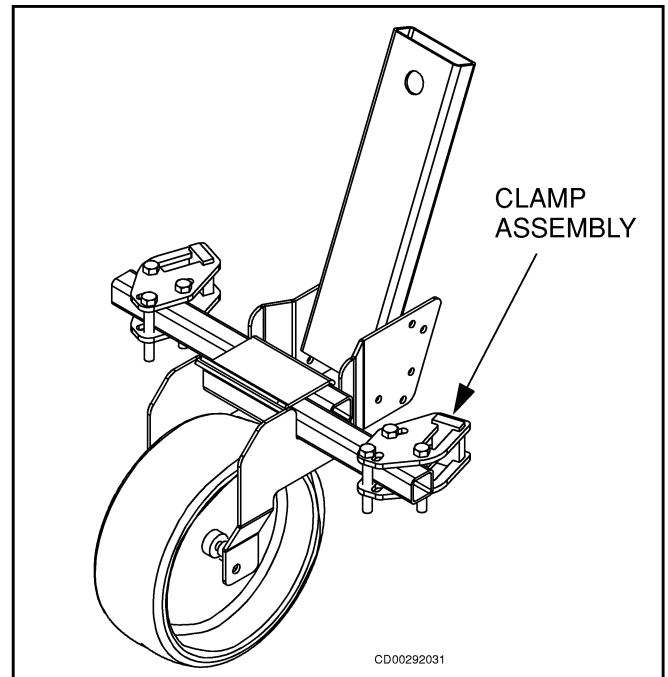

Figure 54 Fastening Clamps to Tubes

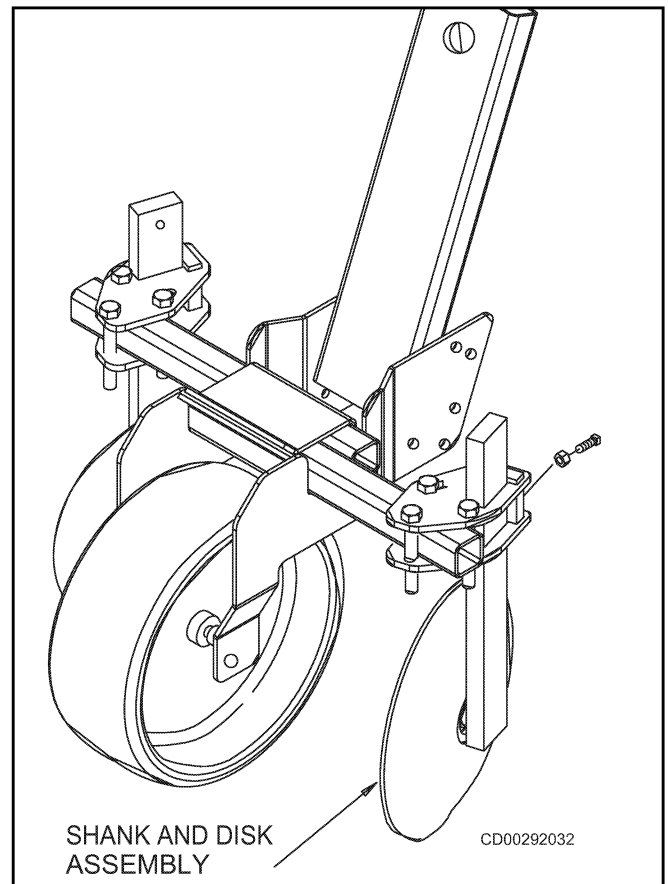

Figure 55 Mounting Discs

Assembly *Cont'd*

Row Weeder Disc Crank

Assemble Crank

1. Thread crank through adjustment nut and secure with 5/8" jam nut and 5/8" flanged nut as shown in Figure 56.
2. Make sure the nuts are jammed together.

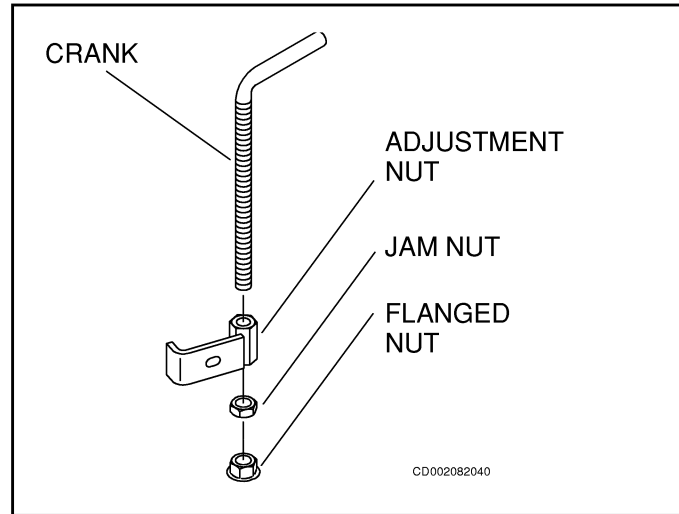

Figure 56 Disc Crank Assembly

Mount Crank Assembly

1. Mount crank assembly to shank, using 3/8 x 1-3/4" hex bolt and flanged nut as shown in Figure 57.
2. Adjust row weeder unit to initial desired setting and tighten all bolts to specifications given in the Bolt Torque Chart.

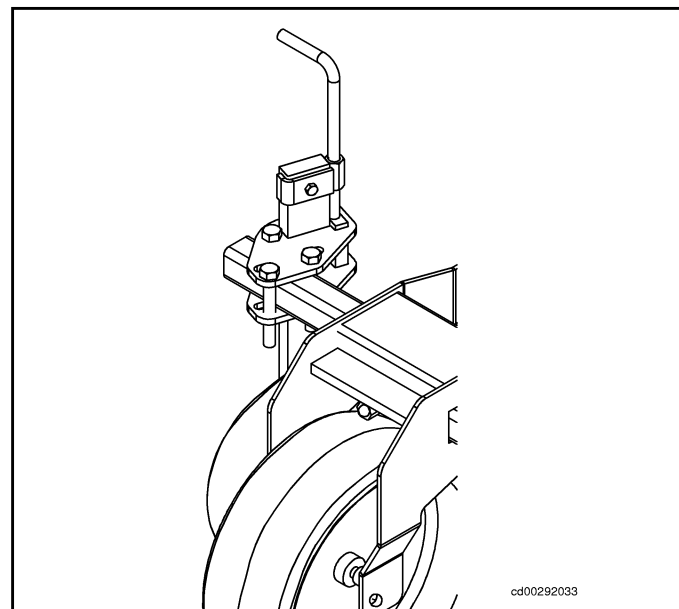

Figure 57 Mounting Crank Assembly

Assembly *Cont'd*

Hiller Attachment

Assemble Hiller

1. Assemble as shown in Figure 58.
2. Install hinge bolt, but do not install nut.

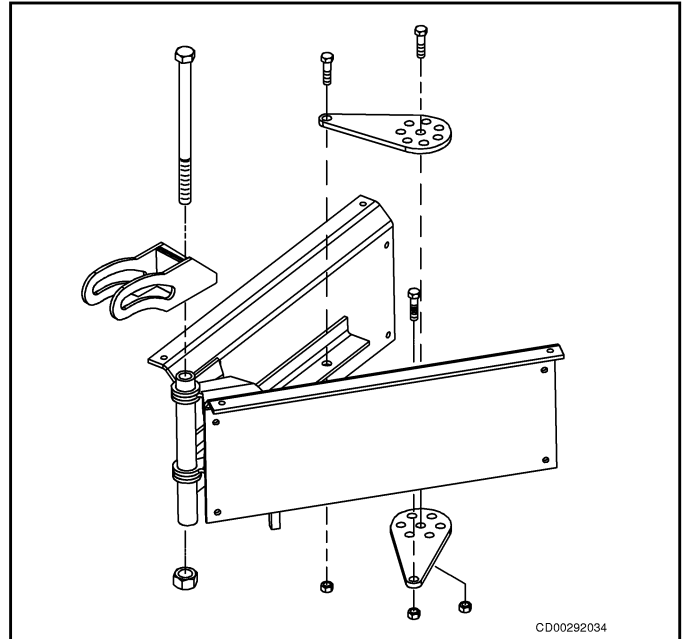

Figure 58 Assembling Hiller

Fasten to Shank

1. Fasten hiller to shank. Use 1/2 NC x 2-1/2" hex bolt and flanged nut through pitch adjustment bracket as shown in Figure 59.
2. Place hinge bolt through sweep shoe and install nut.
3. Adjust hiller assembly to desired setting and tighten nuts to specifications in Bolt Torque Chart.

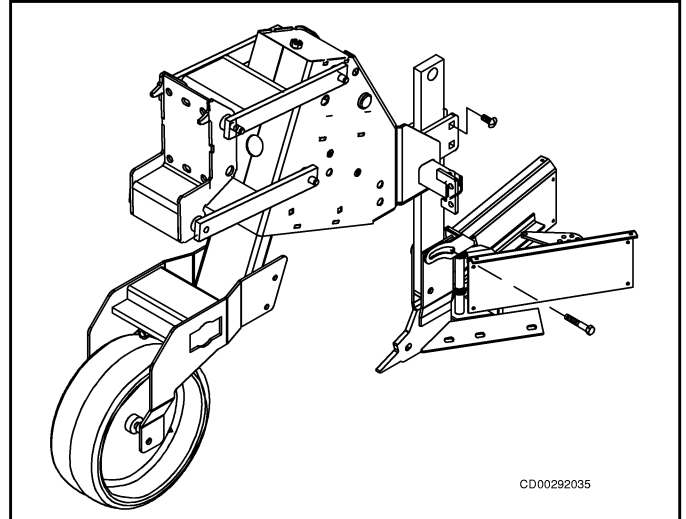

Figure 59 Fastening Hiller to Shank

Assembly *Cont'd*

Lift Assist (TRF or TRR bars only)

Fasten Assembly to Toolbar

1. Fasten frame assembly to toolbar, using 7/8" bolts, lock washers, and hex nuts as shown in Figure 60.
2. Fasten top support to TRF bars with 3/4" U-bolts.

Fasten Hydraulic Cylinder

3. Remove clevis from rod end of hydraulic cylinder and attach depth stop nut as shown in Figure 60.
4. Replace clevis.
5. Fasten hydraulic cylinder to ears on frame and fasten, using pins provided with cylinder.

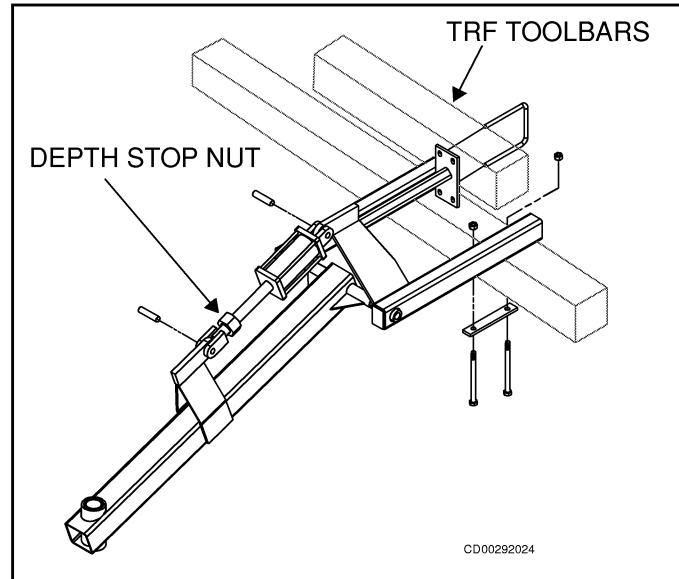

Figure 60 Fastening Lift Assist to Toolbar

Fasten Caster Assembly

1. Remove cap, 1/2 x 1" hex bolt, and lock washer from top of caster assembly as shown in Figure 61.
2. Slide assembly through bushings in frame assembly and fasten, using cap, bolt, and lock washer.
3. Tighten all lift assist bolts to specifications in the Bolt Torque Chart.

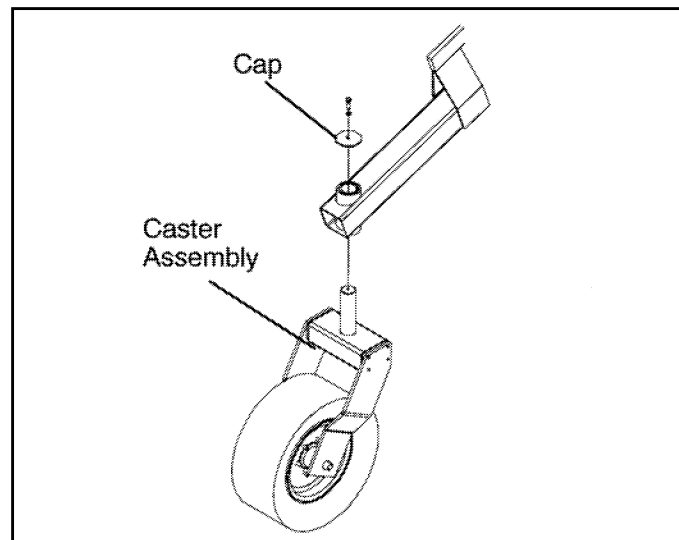

Figure 61 Caster Assembly

Assembly *Cont'd*

Lift Assist (Cont'd)

Mount Hydraulics

1. Attach 6FJIC x 8MORB to hydraulic cylinder.
2. Attach 6FJIC x 6MJIC elbow.
3. Attach hoses to 6FJIC x 6MJIC elbow as shown in Figure 62.
4. When using double lift assist, run 115" hose and 100" hose up to cylinder. Longer hoses go to rod end ports.
5. Run hoses to center of toolbar and fasten tees to hoses as shown in Figure 63.

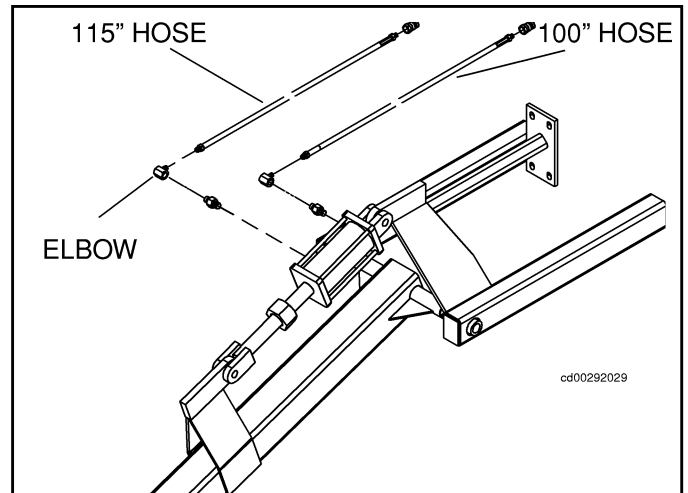

Figure 62 Mounting Hydraulics

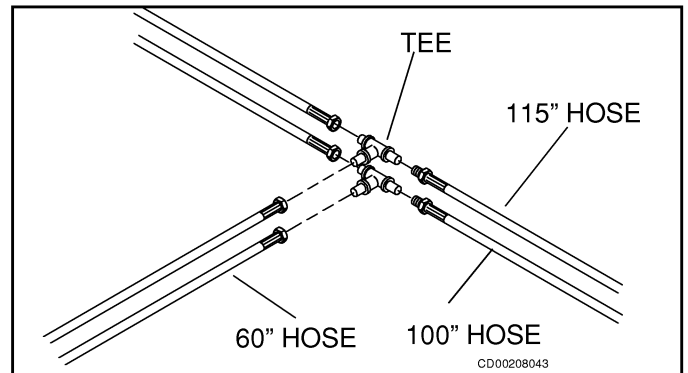

Figure 63 Fastening Tees

Assembly Cont'd

Rear Stabilizer Coultter

Fasten Mounting Frame

1. Fasten mounting frame to toolbar, using backing plate and 7/8" bolt, lock washers, and hex nuts.
2. Make sure frame is centered over cultivator gang.

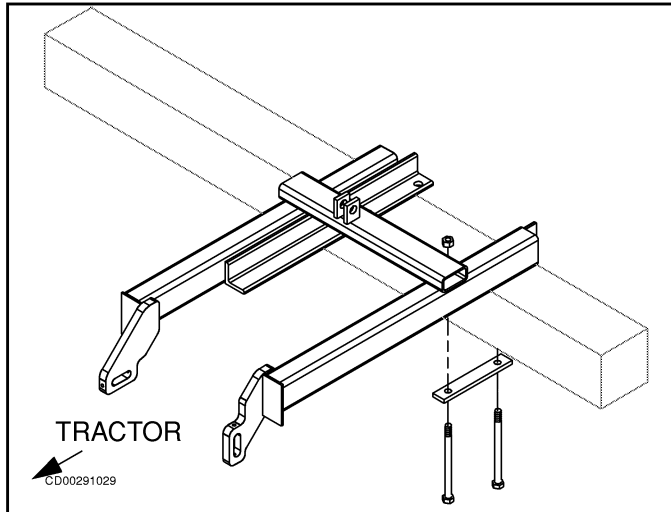

Figure 64 Fastening Mounting Frame

Mounting Rear Frame

1. Fasten rear frame to mounting frame, using two 1 x 5" hex bolts, flat washers, lock washers, and hex nuts.
2. Make sure to place flat washers as shown.
3. Center rear frame, using four 3/8 x 3-1/2" square head set screws with jam nuts.

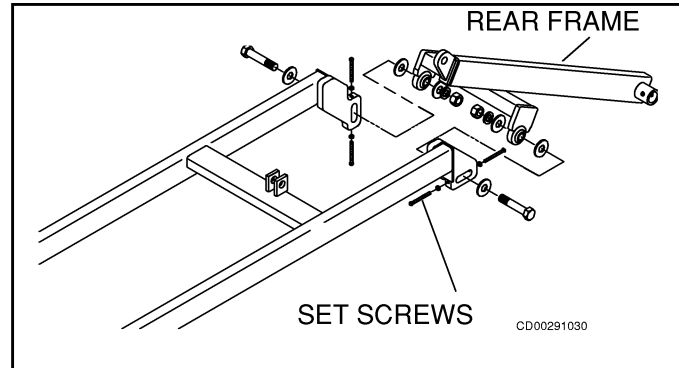

Figure 65 Mounting Rear Frame

Mounting Screw Jack

1. Place rubber bushing into arm weldment and fasten to mounting frame, using 1 x 3-1/2" hex bolt, lock washer, and hex nut.
2. Fasten screw jack to arm weldment and rear frame, using pins provided with screw jack.

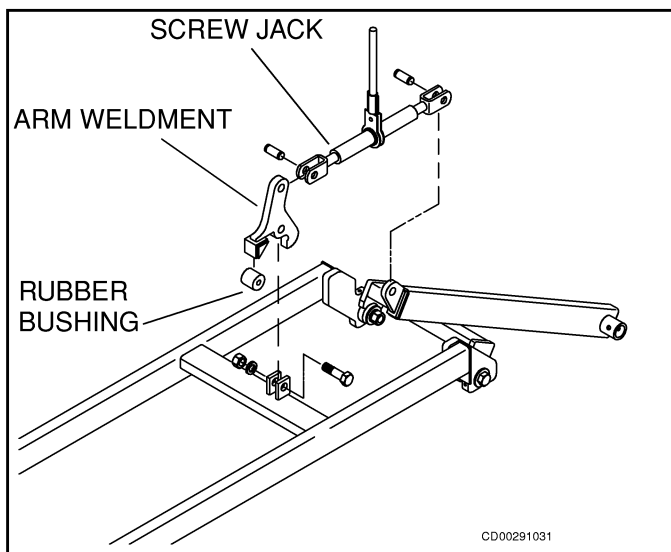

Figure 66 Mounting Screw Jack

Mounting Disc

1. Fasten hub assembly to rear frame, using 1/2 x 3" hex bolt and hex nut.
2. Fasten disc to hub, using 1/2" lock washers and hex nut.

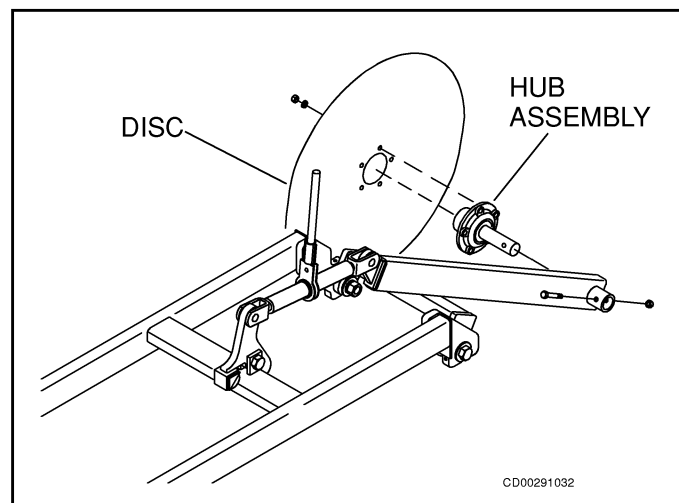
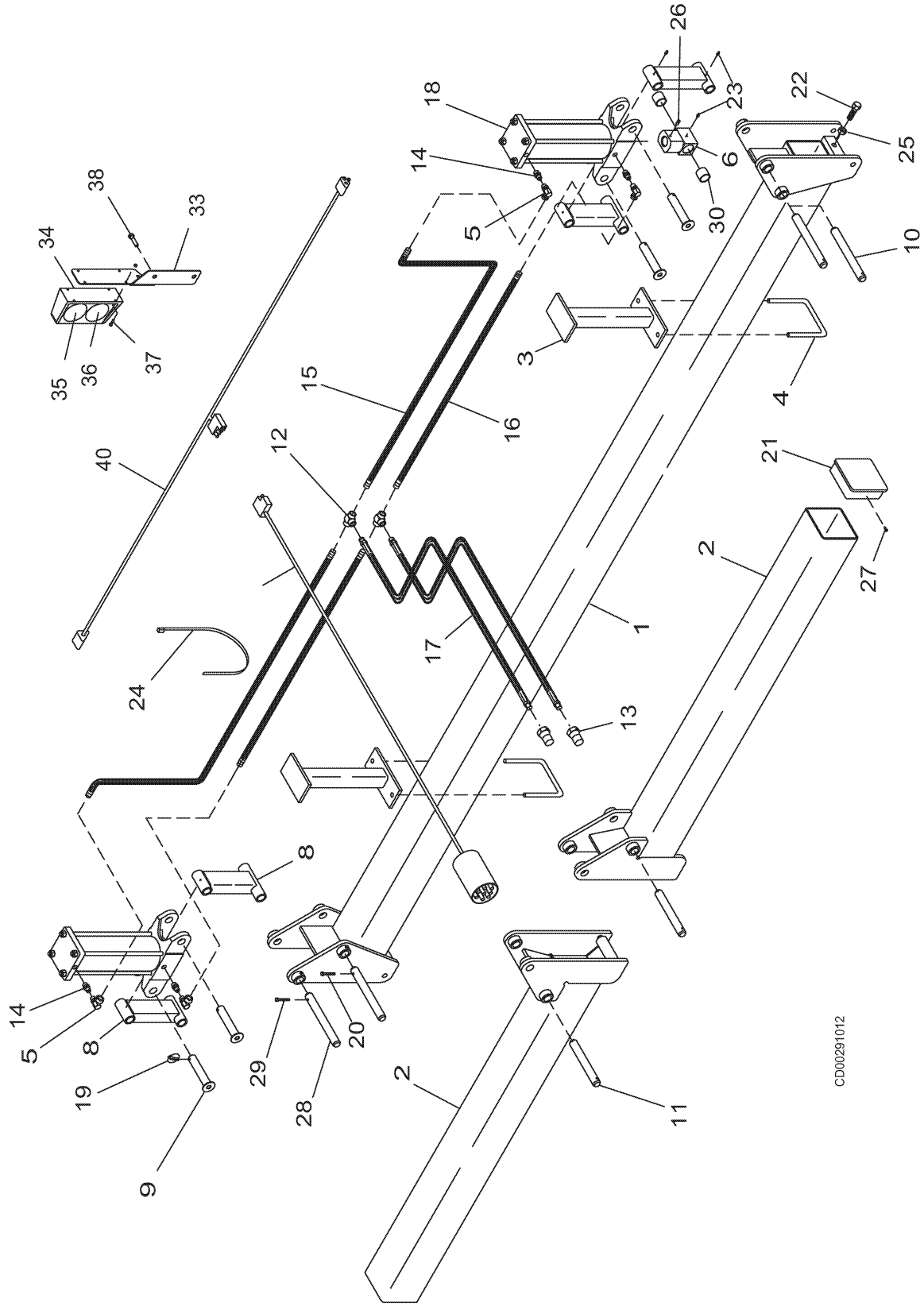

Figure 67 Mounting Disc

Row Crop Cultivator Model 3130

180° FOLD TOOLBAR (F)	66-67
PULL-TYPE HITCH	68
RIGID TOOLBARS (TRR).....	69
HYDRAULICS.....	70
3-POINT HITCH	71
180° SINGLE REINFORCED TOOLBAR (TRF).....	72-74
TOGGLE TRIP ASSEMBLY	74
KING GUIDE STRUT	75
LINKAGE COMPONENTS	76-77
ROW UNIT	78-79
HILLER COMPONENTS.....	80
TINE AND ROW GUIDE COMPONENTS	81
DUAL DISC & DUAL KNIFE ASSEMBLY.....	82
ADJUSTABLE GUIDE AND SUPPORT WHEELS	83
SEMI-PNEUMATIC GUIDE WHEEL & STEEL GUIDE WHEEL.....	84
ROW WEEDER DISCS	85
COULTER DISC COMPONENTS.....	86-89
LIFT ASSIST.....	90-91
OPEN TOP SHIELDS	91
ROLLING SHIELDS	92
PARKING STANDS.....	93

180° FOLD TOOLBAR (F)



CD000291012

66 PARTS

PN-20033738 (Rev. 3/13/03)

180° FOLD TOOLBAR (F) PARTS LIST

REF	PART	QTY	DESCRIPTION	REF	PART	QTY	DESCRIPTION
1	20022042	1	Center section (830)	17	90519146	2	3/8" Hose x 6 FJIC x 8 MORB x 60"
1	20022031	1	Center section (1222)	18	20020503	2	5 x 12 Cylinder complete with clevis
1	20022032	1	Center section (1224)	18	20020500	2	5 x 12 Cylinder less clevis
2	20022018	2	Wing weld (830)	18	90521263	1	Seal kit, 5 x 12 cylinder
2	20022017	2	Wing weld (1222 & 1224)	19	90025010	4	1/4 x 1-1/4 Klik pin
3	20020321	2	Wing rest	20	90001071	4	5/16 x 2-1/2 Hex bolt GR5
4	20030344	2	5/8" U-Bolt for 7 x 7 beam	21	20032636	2	Rubber tube cap, 7 x 7
5	90503163	4	Elbow, 6 MJIC x 6 FJIC x 90°	22	90003024	4	3/4 NC x 2-1/2 Hex bolt GR5 full thread
6	20033324	2	Clevis	23	90515024	10	Zerk, 1/4-28 UNF Straight
6	20021776	2	Clevis assy., 1-1/2" I.D.	24	90507086	6	32" Plastic cable tie
7	20020317	2	Cylinder linkage, wing	25	90006282	4	3/4 NC Jam nut
8	20020316	2	Cylinder linkage, center	26	90016033	2	3/4 NC x 1 Sq. head set screw
9	20021371	4	Cylinder pin	27	90016897	4	#6 x 3/4 Pan head sheet metal screw
10	20030513	4	Cylinder pin 1-1/4" x 11-1/4" long	28	20033431	2	Hinge pin, 1-1/2 x 11-1/4
11	20030526	2	Pin 1-1/4 x 9-5/8" long	29	90001125	2	3/8 x 3 Hex bolt GR5
12	90503112	2	Tee, 6 MJIC	30	20033285	4	Garmax bushing, 1-1/2" I.D.
13	90519126	2	Quick coupler, male tip	33	20033870	1	Light bracket, RH
14	90503162	4	6 MJIC x 8 MORB Restrictor, 1/16"	NS	20033869	1	Light bracket, LH
15	90519119	2	3/8" Hose x 6 FJIC x 6 FJIC x 100"	34	90401150	1	Dual tail light, RH
15	90519147	2	3/8" Hose x 6 FJIC x 6 FJIC x 111"	NS	90401149	1	Dual tail light, LH
15	90519121	2	3/8" Hose x 6 FJIC x 6 FJIC x 120"	35	90401142	4	Amber tail light
15	90519148	2	3/8" Hose x 6 FJIC x 6 FJIC x 142"	36	90401146	2	Red tail light
16	90519152	2	3/8" Hose x 6 FJIC x 6 FJIC x 82"	37	90001009	8	1/4 NC x 1 Hex bolt GR5
16	90519119	2	3/8" Hose x 6 FJIC x 6 FJIC x 100"	38	90001341	4	5/8 NC x 1-1/2 Hex bolt GR5
16	90519147	2	3/8" Hose x 6 FJIC x 6 FJIC x 111"	39			
16	90519151	2	3/8" Hose x 6 FJIC x 6 FJIC x 134"	40	90401152	1	Wire harness
				NS	20013731	1	Safety decal
				NS	90401147	4	Tail light bulb

NS = Not Shown

PULL-TYPE HITCH COMPONENTS

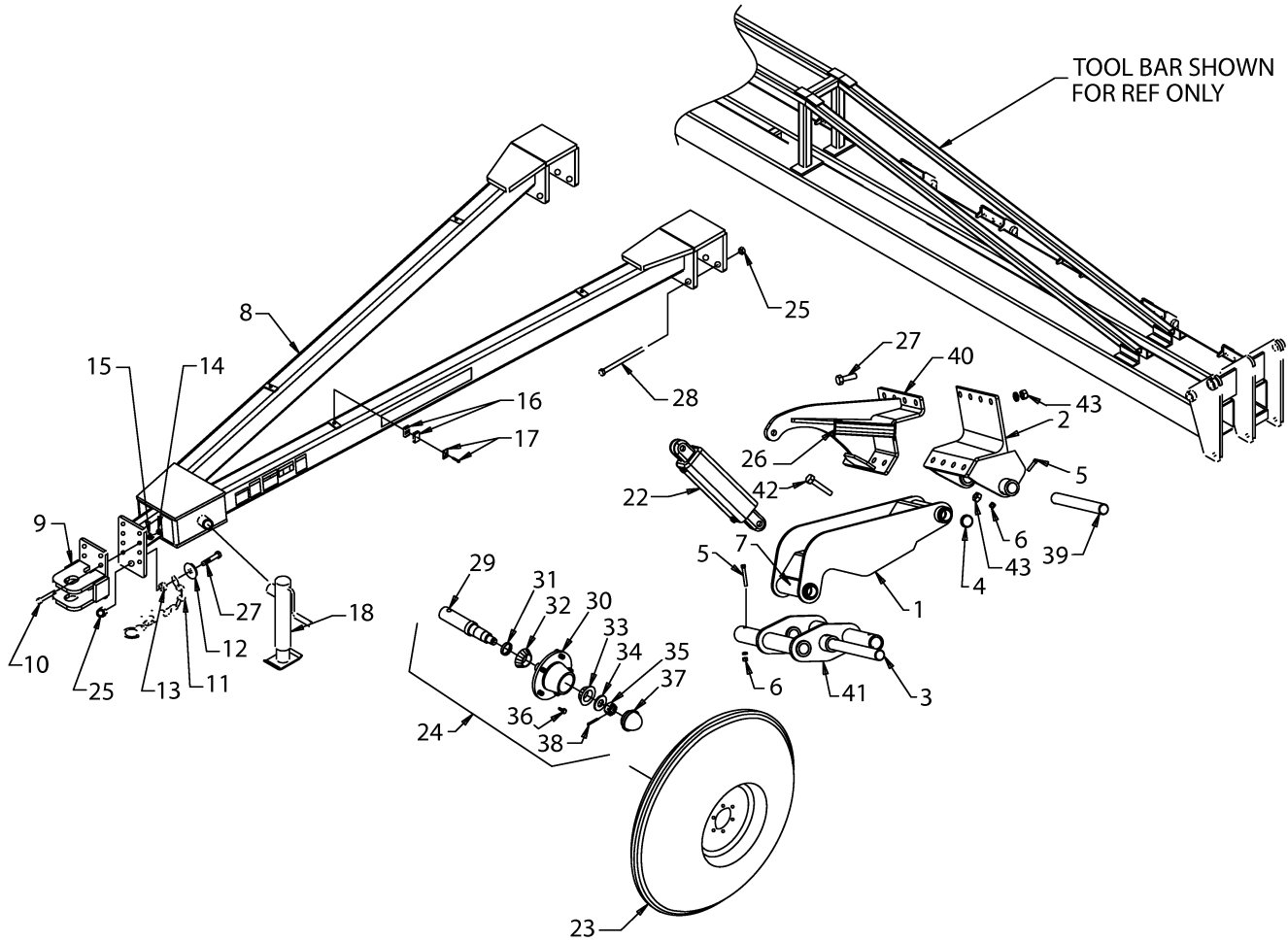

REF	PART	QTY	DESCRIPTION	REF	PART	QTY	DESCRIPTION
1	20022131	2	Strut weld	17	90031068	4	Top plate
2	20022133	2	Lower mount weld	18	90523004	1	Jack
3	20034085	2	Pivot pin, short	19	90042055	4	Lock pin
4	20034081	4	Bushing	20	50031678	2	Chain
5	90001241	4	1/2 NC x 3.5 Hex bolt	21	90023043	16	3-16 x 1-1/2 Cotter
6	90006143	4	1/2 NC Spiral lock nut	22	90521414	2	4 x 12 Hydraulic cylinder
7	90515001	4	1/8 NPT Straight zerk	22	90521415	1	SEAL-KIT, 4 x 12 Hyd Cyl
8	20022107	1	Hitch	23	90509145	4	11 x 24 Wheel/tire assembly
9	20022129	1	Clevis Weld	23	90509143	4	Tire, 11.0 x 16 single rib
10	90003051	4	5/8 x 2-1/2 Hex head cap screw GR8	23	90509146	4	Wheel rim, 16 x 10, 8 bolt
11	90507113	1	Tow chain	24	70020165	4	Hub assembly / pt. hitch (Includes items 29-38, page 69)
12	50031631	1	1.03 x 3.25 Washer	25	90006514	7	1 NC Top lock nut
13	50530713	1	Bushing spacer	26	20022160	2	Transport lock
14	90006281	4	5/8 NC Jam nut ZP	27	90001519	8	1 NC x 3 Hex bolt
15	90006014	4	5/8 NC Hex nut ZP	28	90001551	6	1 NC x 10 Hex bolt GR5
16	90031069	4	3/8 Hose clamp				Continued on next page

PULL-TYPE HITCH COMPONENTS (CONT'D)

Continued from previous page

REF	PART	QTY	DESCRIPTION	REF	PART	QTY	DESCRIPTION
29	700-3-0143	1	Spindle	37	90109135	1	Dust cap
30	90509136	1	Hub with cups	38	90023064	1	1/4 x 2 Cotter pin
31	90109215	1	Seal	39	20034043	1	Pivot Pin
32	90101325	1	Bearing cone	40	20022132		Ear weld PTH
33	90101326	1	Bearing cone	41	20022130		Pivot weld 22"
34	90509067	1	Washer		20022160		Pivot weld 30"
35	90006060	1	7/8 Slotted nut	42	90001529		1" x 4.5 HHCS
36	90509039	8	9/16 Wheel bolt	43	90006019		1" NC nut

RIGID TOOLBARS (TRR)

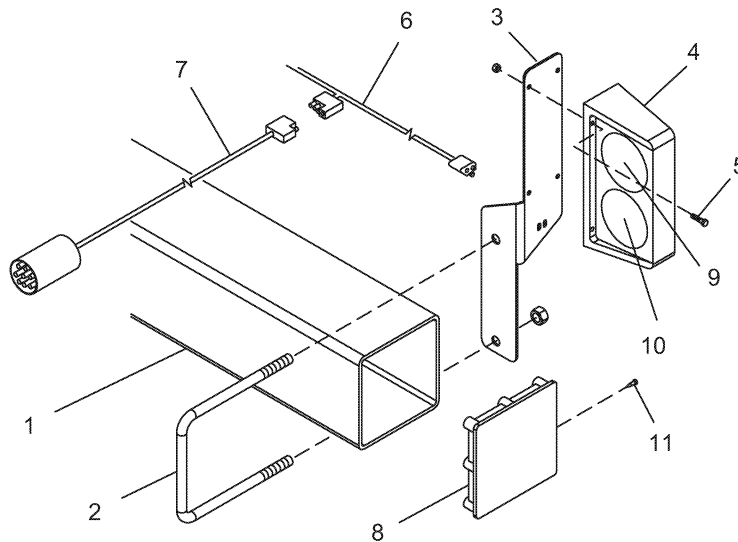

CD00291014

REF	PART	QTY	DESCRIPTION	REF	PART	QTY	DESCRIPTION
1	20022126	1	Toolbar, 7 x 7 x 157.5" 6-22	5	90001009	4	1/4 NC x 1 Hex bolt GR5
1	20022124	1	Toolbar, 7 x 7 x 1/4 x 213.5" 6-30/8-22	6	90401152	1	Wire harness,
1	20022125	1	Toolbar, 7 x 7 x 1/4 x 273.5" 8-30	7	XXXXXXX	1	Order Item #6
1	20022063	1	Toolbar, 7 x 7 x 1/4 x 288" 12-22	8	20032636	2	Rubber tube cap
2	20030344	2	U-Bolt, 5/8 NC x 7 x 8.5 long	9	90401145	2	Amber tail light
3	20033869	1	Light bracket, LH	10	90401146	2	Red tail light
NS	20033870	1	Light bracket, RH	11	90016897	2	#6 x 3/4 Pan head sheet metal screw
4	90401149	1	Dual tail light, LH	NS	20013730	1	Safety decal set
NS	90401150	1	Dual tail light, RH	NS	90401147	AR	Tail light bulb

NS = Not Shown
AR = As Required

HYDRAULICS

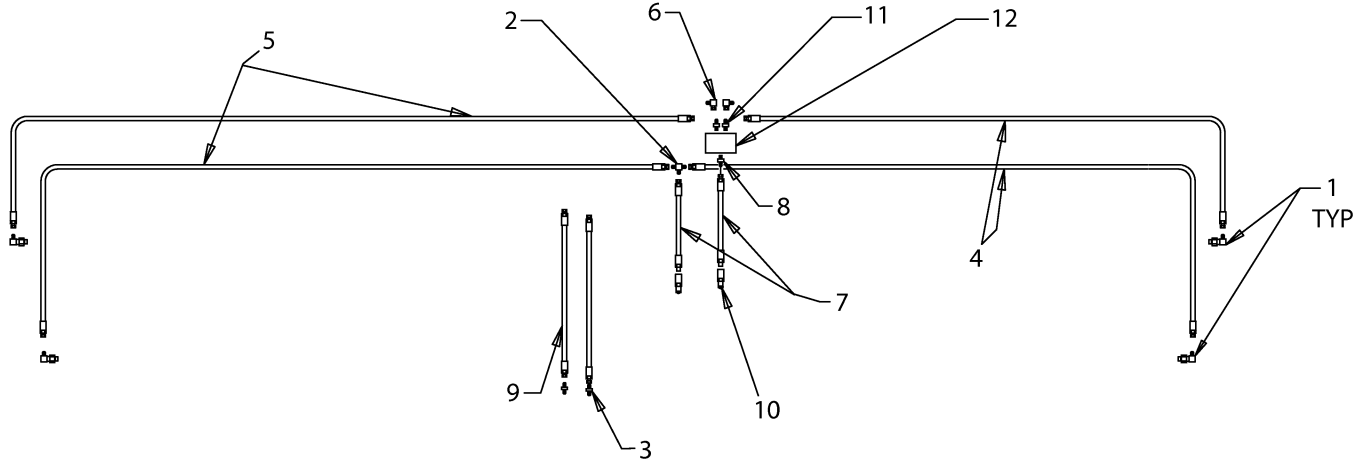

REF	PART	QTY	DESCRIPTION	REF	PART	QTY	DESCRIPTION
1	905-03114	4	90° Elbow, 6MJIC x 3/4-16 MORB	7	905-19157	2	3/8 Hose 166", 6FJ svl x 8 MORB
2	905-03112	1	Tee, 6 MJIC 3-way	8	905-03115	1	Adapter, 6MJIC x 3/4-16 MORB
3	905-03111	2	Nipple, 6 MJIC	9	905-19155	2	3/8 Hose 120", 6FJ svl x 6FJ svl
4	905-19125	4	3/8 Hose 62", 6FJ svl x 6FJ svl	10	901-19126	2	Quick coupler, pioneer end
5	905-19151	2	3/8 Hose 134", 6FJ svl x 6FJ svl	11	905-03120	2	Adapter, 6MJIC x 6MORB
6	905-03163	2	90° Elbow, 6-MJIC x 6 FJIC	12	905-03175	1	Hydraulic flow divider

70 PARTS

PN-20033738 (Rev. 12/03)

3-POINT HITCH

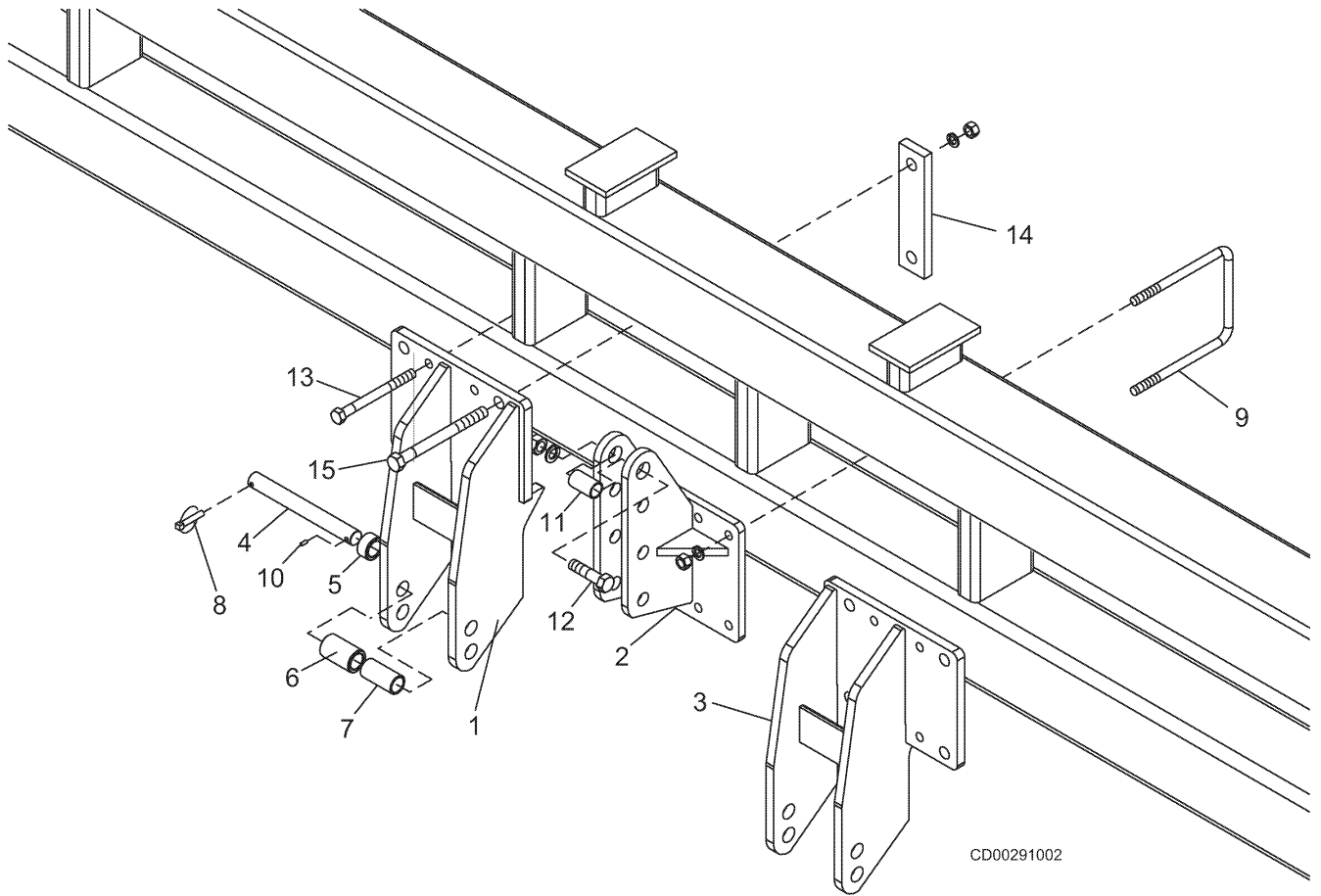

REF	PART	QTY	DESCRIPTION	REF	PART	QTY	DESCRIPTION
1	20022043	1	Lower 3-point hitch weld (RH 22" and LH 30" & 24 row units)	6	20030959	2	Spacer, 1-3/4 O.D.
1	20022046	1	Lower 3-point hitch weld (RH, 24" row spacing)	7	20030961	2	Bushing, 1-7/16 O.D. x 3 long
2	20022045	1	Upper mast weld	8	90025012	2	7/16 x 2 Klik pin
3	20022041	1	Lower 3-point hitch weld (LH 22" and RH 30" & 24 row units)	9	20030345	2	U-Bolt, 3/4 NC x 7 x 9/12 long
3	20022047	1	Lower 3-point hitch weld (LH, 24" row spacing)	10	90029204	2	Roll pin, 5/16 x 1-5/8 long
4	20030962	2	Pin	11	20030151	1	Mast spacer bushing, 1" I.D.
4	20020553	2	Pin assembly (Ref 4, 10)	12	90001531	1	1" NC x 5 Hex bolt GR5
5	20030960	2	Spacer, 1-3/4 O.D. x 1 long	13	90001381	8	5/8 NC x 9 Hex bolt GR5
				14	20030970	4	Strap
				15	90003039	4	7/8 NC x 10 Hex bolt GR5

180° SINGLE REINFORCED TOOLBAR (TRF)

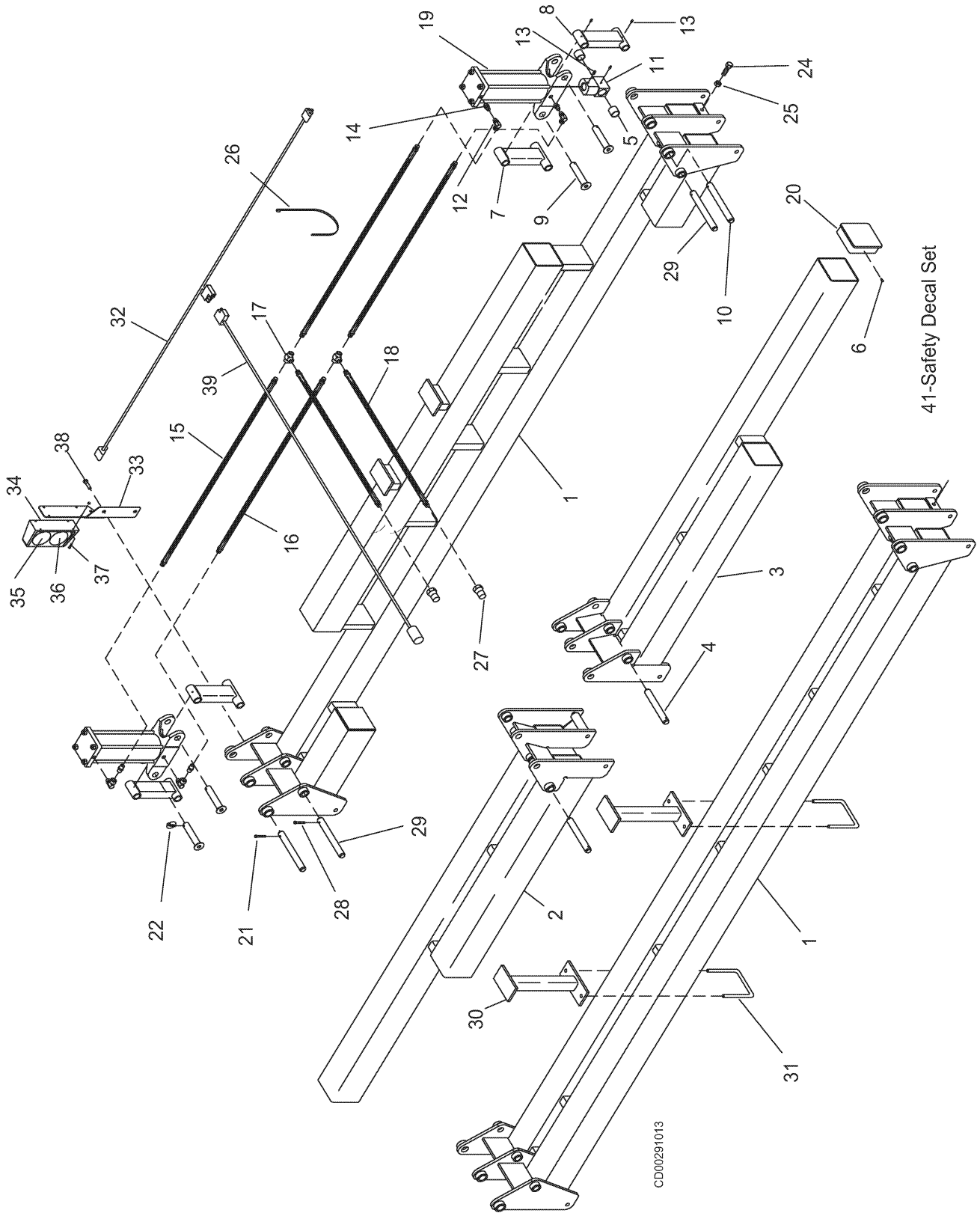

41 - Safety Decal Set

CD00291013

72 PARTS

PN-20033738 (Rev. 12/03)

180° FOLD TOOLBAR (TRF) PARTS LIST

REF	PART	QTY	DESCRIPTION	REF	PART	QTY	DESCRIPTION
1	20022036	1	Center section 180" (8-36)	15	90519147	2	3/8" Hose x 6 FJIC x 6 FJIC x 111" (184" center)
1	20022037	1	Center section 200" (840)	15	90519121	2	3/8" Hose x 6 FJIC x 6 FJIC x 120" (202" center, 198" center)
1	20022038	1	Center section 196" (1228)	15	90519148	2	3/8" Hose x 6 FJIC x 6 FJIC x 142" (242" center)
1	20022034	1	Center section 210" (1230)	15	90519149	2	3/8" Hose x 6 FJIC x 6 FJIC x 152" (264" center)
1	20022039	1	Center section 224" (12-38)	15	90519150	2	3/8" Hose x 6 FJIC x 6 FJIC x 160" (286" center)
1	20022035	1	Center section 198" (1622)	16	90519119	2	3/8" Hose x 6 FJIC x 6 FJIC x 100"
1	20022044	1	Center section 270" (1630)	16	90519147	2	3/8" Hose x 6 FJIC x 6 FJIC x 111"
2	20021987	1	Left wing 74" (836)	16	90519151	2	3/8" Hose x 6 FJIC x 6 FJIC x 134"
2	20021990	1	Left wing 82" (840)	16	90519148	2	3/8" Hose x 6 FJIC x 6 FJIC x 142"
2	20021993	1	Left wing 86" (1228)	16	90519149	2	3/8" Hose x 6 FJIC x 6 FJIC x 152"
2	20021312	1	Left wing 92" (1230)	17	90503112	2	Tee, 6 MJIC
2	20021996	1	Left wing 98" (1232)	18	90519146	2	3/8" Hose x 6 FJIC x 60"
2	20021984	1	Left wing 90" (1622)	19	20020503	2	5 x 12 Cyl complete w/clevis
2	20022002	1	Left wing 122" (1630)	19	905-21258	4	Tie Rod Bolt, 5x12
2	20021999	1	Left wing 92" (1822)	19	20020500	2	5 x 12 Cylinder less clevis
2	20021388	1	Left wing 134" (2422)	19	90521263	1	Seal kit, 5 x 12 cylinder
3	20021988	1	Right wing 74" (836)	19	90521382	1	5 x 12 Cylinder rod
3	20021991	1	Right wing 82" (840)	19	90521383	1	5 x 12 Cylinder rod cap
3	20021994	1	Right wing 86" (1228)	19	90521384	1	5 x 12 Cylinder cap
3	20021311	1	Right wing 92" (1230)	19	20021564	1	6 x 12 Cyl complete w/clevis
3	20021997	1	Right wing 98" (1232)	19	905-21413	4	Tie Rod Bolt, 6x12
3	20021985	1	Right wing 90" (1622)	19	90521410	4	6 x 12 Cylinder less clevis
3	20022003	1	Right wing 122" (1630)	19	90521411	1	6 x 12 Cylinder rod piston
3	20022000	1	Right wing 92" (1822)	19	90521387	1	6 x 12 Cylinder rod cap
3	20021387	1	Right wing 134" (2422)	19	90521412	1	6 x 12 Cylinder cap
4	20030526	1	Pin, 1-1/4 x 9-5/8" long	19	90521368	1	Seal kit, 6 x 12 cylinder
5	20033285	4	1-1/2" Garmax bushing	19	20021762	1	Clevis assy. (1-1/4 pin)
5	20033355	4	1-1/4" Garmax bushing	19	90521385	1	1-1/4" Nut
6	90016897	4	#6 x 3/4 Pan head sheet metal screw	20	20032636	4	Rubber tube caps, 7 x 7
7	20020316	2	Cylinder linkage, center	21	90001071	6	5/16 x 2-1/2 Hex bolt GR5
8	20020317	2	Cylinder linkage, wings	22	90025010	4	1/4 x 1-1/4 Klik pin
9	20021611	4	Pin, cylinder linkage	24	90003024	4	3/4 NC x 2-1/2 Hex bolt GR5
10	20032450	4	Hinge pin, 1-1/4" x 19-3/4" long	25	90006282	4	3/4 NC Jam nut
11	20033324	2	Clevis	26	90507085	6	15" Plastic cable ties
11	20021776	2	Clevis assembly, 1-1/2" I.D. with bushings (Ref. Figure 5 & Figure 10)	27	90519126	2	Quick coupler
12	90503163	4	Elbow, 6 MJIC x 6 FJIC 90°				
13	90515024	10	Zerk, 1/4-28 UNF, straight				
14	90503162	4	6 MJIC x 8 MORB Restrictor				

180° SINGLE REINFORCED TOOLBAR (TRF) PARTS LIST (CONT'D)

REF	PART	QTY	DESCRIPTION	REF	PART	QTY	DESCRIPTION
28	90001071	2	5/16 NC x 2-1/2 Hex bolt GR5 (1-1/4" Hinge pin)	34	90401150	1	Dual tail light, RH
28	90001125	2	3/8 NC x 3 Hex bolt GR5 (1-1/2" Hinge pin)	NS	90401149	1	Dual tail light, LH
29	20033170	2	Hinge pin, 1-1/2" x 19-3/4" long	35	90401145	2	Amber tail light
30	20020321	2	Stand	36	90401146	2	Red tail light
31	20030344	2	Wing rest U-bolt	NS	90401147	2	Tail light bulb
32	90401152	1	Wire harness,	37	90001009	8	1/4 NC x 1 Hex bolt GR5
33	20033870	1	Light bracket, RH	38	90001341	4	5/8 NC x 1-1/2 Hex bolt GR5
NS	20033869	1	Light bracket, LH	41	20013730	1	Safety decal set

TOGGLE TRIP

REF	PART	QTY	DESCRIPTION
1	20020592	1	Toggle trip
2	20031038	1	Plate, spring attachment, upper
3	20031034	1	Toggle trip bar, no threads
4	20031033	1	Toggle trip bar, threaded holes
5	20031040	1	Ear
6	20020591	1	Toggle Trip Pivot
7	20022099	1	Rear Set Back
8	20031036	1	Plate, Spring Attachment, lower
9	20031745	2	Spring Painted
10	90001792	3	5/8 NC x 3-1/2 Carriage Bolt
11	90001403	2	3/4 NC X 2 Hex bolt
12	90016068	2	1/2 NC X 2-1/2 Sq head socket screw
13	90001407	2	3/4 NC X 2-1/2 Hex bolt
14	90016118	1	3/4 NC X 3-1/2 Sq head socket screw
15	90006619	1	3/4 NC Sqr Nut

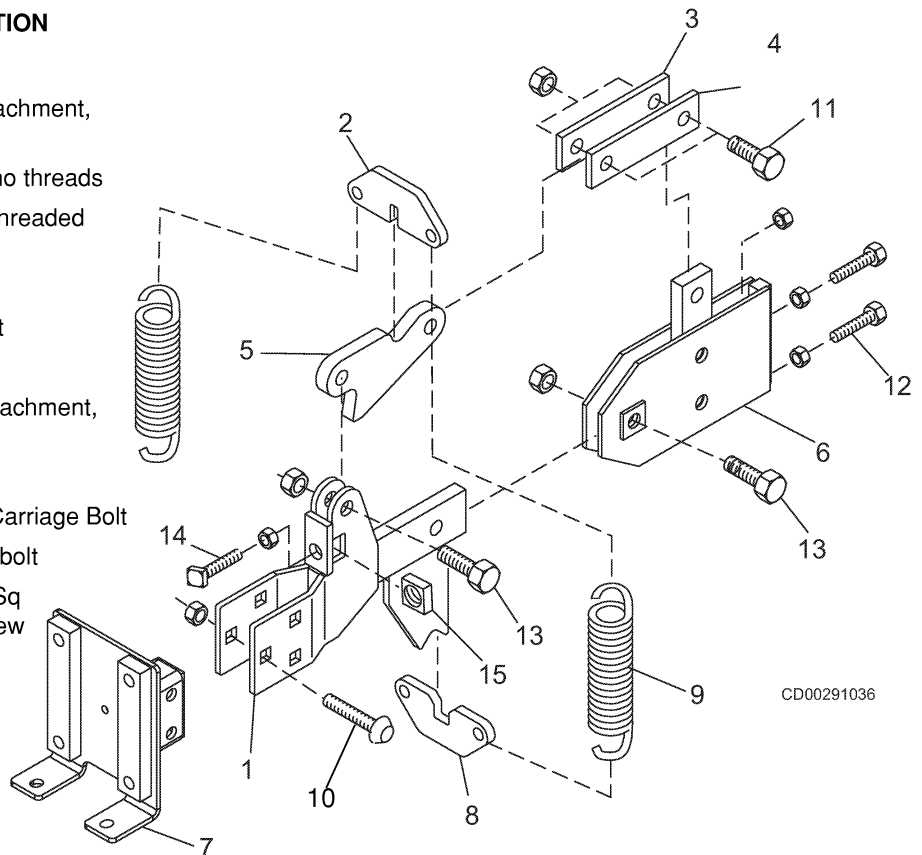

CD00291036

KING GUIDE STRUT ASSEMBLY

REF	PART	QTY	DESCRIPTION	REF	PART	QTY	DESCRIPTION
1	20021948	1	King guide mast weld	21	90001399	2	3/4 NC x 1-1/2" Hex bolt GR5
2	20021947	1	Inner yoke	22	90001341	2	5/8 NC x 1-1/2 Hex bolt
3	20033783	1	Threaded trunion	23	20033438	1	1/4 Rnd x 2-3/8 UHMW
4	20021937	1	Pivot weld	24	90016237	1	5/16 NC X 5/16 Socket head screw
5	20020988	1	Tire and rim assy.	25	90029182	1	1/4 x 2 Roll pin
—	90509014	1	Rim 16 x 6, 6 bolt	26	90023025	1	CotterPin
—	90509019	1	Tire 6.00 x 16 single rib	27	90006052	1	1/2 NF Castle nut
6	20033523	1	Trunion	28	90001225	1	1/2NC X 1-1/2 Hex bolt GR5
7	20033743	1	Pivot bar	29	90006143	1	1/2 NC Flange lock nut
8	20031443	2	"A" Bolt 7/8 x 7 x 7"	30	20021958	1	Hub with spindle assy. (Ref. Figure 9 to Figure 18)
9	20033771	1	Spindle				
10	90509082	1	"Hub with cups				
11	90109127	2	Seal				
12	90101149	2	Bearing cone				
13	20032726	1	Nut, short				
14	20033791	2	Washer, 0.2-3/4 O.D. x 1.63 I.D.				
15	20033754	2	Nut, shoulder				
16	90509011	6	Wheel nuts 1/2 NF				
17	90101148	2	Bearing cup				
18	90006024	1	1-1/4-12 NF Hex nut				
19	20022020	1	Pitch adjustment screw				
20	20033190	1	Adjustment screw				

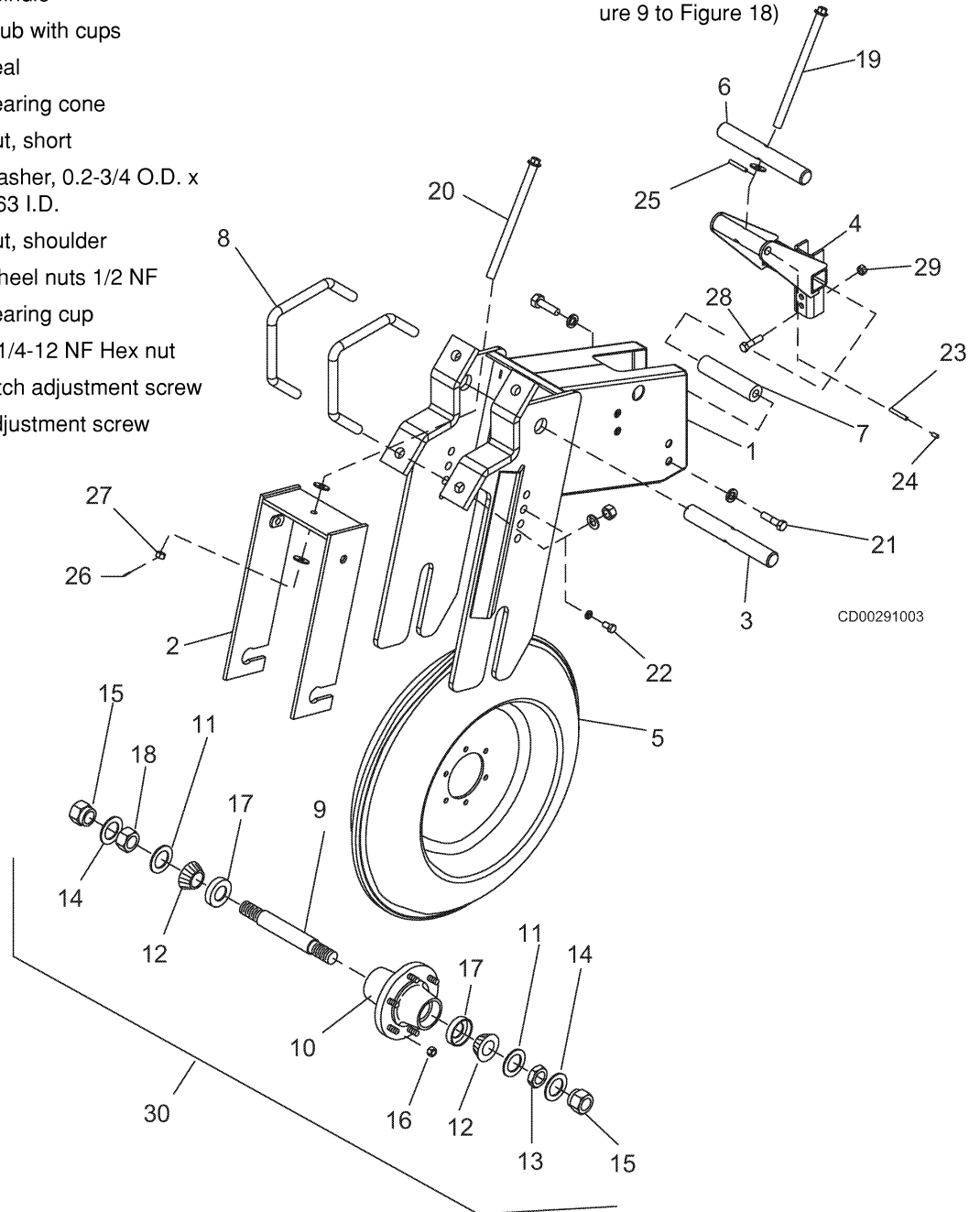

CD00291003

LINKAGE COMPONENTS

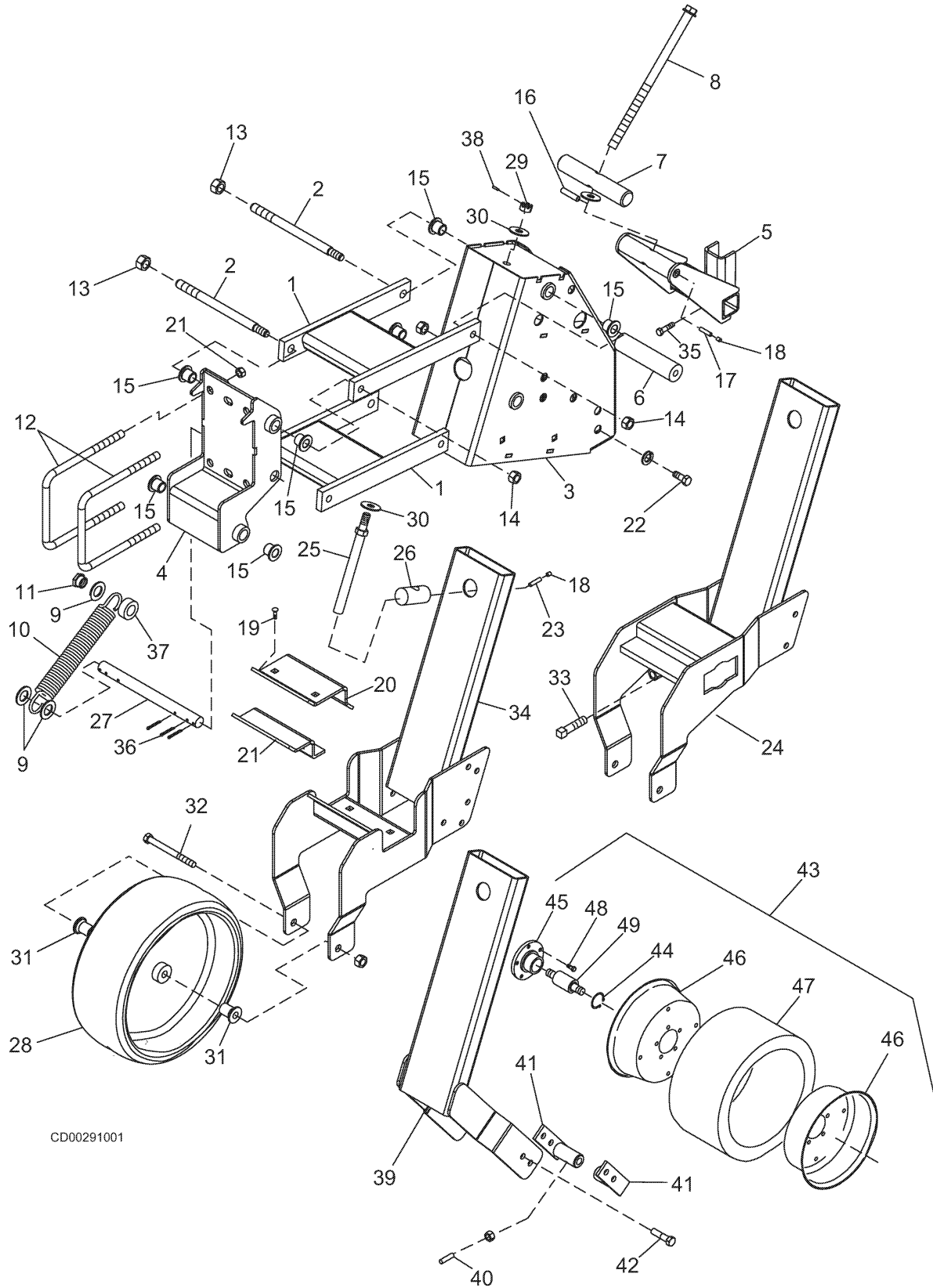

CD00291001

76 PARTS

PN-20033738 (Rev. 12/03)

LINKAGE COMPONENTS PARTS LIST

REF	PART	QTY	DESCRIPTION	REF	PART	QTY	DESCRIPTION
1	20021933	2	H-Linkage weld	28	90501937	1	6 x 16 Wheel assy.
2	20033756	4	Pivot pin 11" long	NS	90509138	AR	Tire for 90501937
3	20021936	1	Mast weld w/o bushings	NS	90509139	AR	Rim 1/2 for 90501937
4	20021932	1	Mounting angle w/o bushings	NS	90509140	AR	Bearing for 90501937
5	20021937	1	Pivot weld	29	90006705	1	5/8 NC Slotted hex nut
6	20033743	1	Pivot bar	30	90011037	2	5/8 Flat washer
7	20033523	1	Trunion	31	90308424	2	Wheel spacer
8	20022020	1	Screw, pitch adj.	32	90001369	1	5/8 NC X 6 Hex bolt GR5
9	90011073	6	10 ga machinery bushing	33	90016097	1	5/8 NC X 2-1/2 Sqr. head set screw
10	20032163	2	Down pressure spring	34	20022095	1	Gage wheel mast, after SN 24230
11	20033873	1	3/4 NC Shoulder nut right	35	90001225	1	1/2 NC x 1-1/2 Hex bolt
NS	20033872	1	5/8 NC Shoulder nut left	36	90023043	6	3/16 x 1-1/2 Cotter pin
12	20030344	2	U-bolt 5/8 NC x 7 x 8.5	37	50530713	2	Spacer bushing
13	90006510	4	3/4 NC Top lock nut	38	90029470	1	3/16 x 7/8 Roll pin
14	90006145	4	5/8 NC Flange lock nut	39	20022058	1	Wheel arm, guide row
15	20030877	8	Bushing Flanged	40	90016031	2	3/8 NC X 3/4 Sqr head set screw
16	90029182	1	1/4 x 2 roll pin	41	20021705	2	Wheel holder
17	20033438	1	1/4 RND X 2-3/8 UHMW	42	90001223	4	1/2 NC x 1-1/4 Hex bolt
18	90016237	2	5/16 X 5/16 Socket set screw	43	20021685	1	6" Gauge tire with fork hub (includes items 44-49)
19	90001726	4	7/16 x 1-1/2 Carriage bolt	44	90039022	1	Retaining ring
20	20032533	1	Double tube clamp	45	20030669	1	Hub
21	20030994	1	Single tube clamp	46	20033106	2	Rim half, 6 x 12 wheel
22	90001399	2	3/4 NC x 1-1/2 Hex bolt GR5	47	20033107	1	Gauge wheel tire 6 x 12
23	20033437	1	1/4 RND X 7/8 UHMW	48	90001055	5	5/16 NC x 3/4 Hex bolt
24	20021938	1	Gauge wheel mast, prior to S/N 24229	49	90101264	1	Fork type wheel bearing
25	20021945	1	Screw, depth adj.				NS = Not Shown
26	20033201	1	Trunion, threaded				AR = As Required
27	20033871	1	Down pressure spring rod				

ROW UNIT (RESET SHANK)

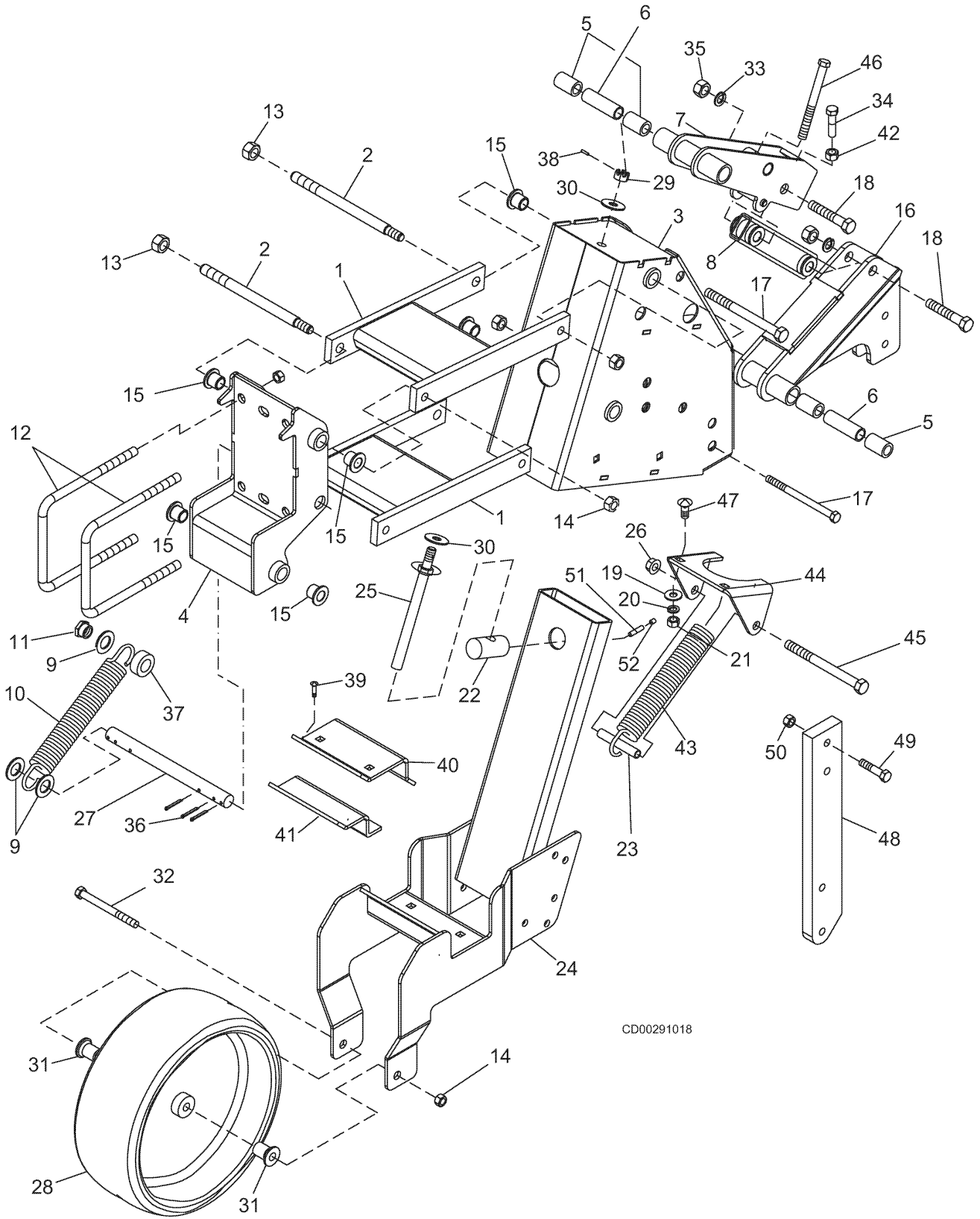

CD00291018

78 PARTS

PN-20033738 (Rev. 12/03)

ROW UNIT (RESET SHANK) PARTS LIST

REF	PART	QTY	DESCRIPTION	REF	PART	QTY	DESCRIPTION
1	20021933	2	H-Linkage weld	28	90501937	1	6 x 16 Wheel assy.
2	20033756	4	Pivot pin	—	90509138	AR	Tire for 90501937
3	20021936	1	Mast weld w/o bushings	—	90509139	AR	Rim half for 90501937
4	20021932	1	Mounting angle w/o bushings	—	90509140	AR	Bearing for 90501937
5	20033910	4	Oilite bushing	29	90006705	1	5/8 NC Slotted hex nut
6	20033902	2	Bushing, center spacer	30	90011037	2	5/8 Flat washer
7	20021935	1	Upper toggle trip arm	31	90308424	2	Wheel spacer
8	20021934	1	Lower pivot arm with bushing	32	90001369	1	5/8 NC X 6 Hex bolt GR5
9	90011073	6	10 ga. Machinery bushing	33	90011017	4	3/4 Lock washer
10	20032163	2	Down pressure spring	34	90002526	1	1/2 NC X 2-3/4 F.T.Tap bolt
11	20033873	1	3/4 NC Shoulder nut right	35	90006015	4	3/4 Hex nut
NS	20033872	1	5/8 NC Shoulder nut left	36	90023043	6	3/16 x 1-1/2 Cotter pin
12	20030344	2	U-bolt 5/8 NC x 7 x 8.5	37	50530713	2	Spacer bushing
13	90006510	4	3/4 NC Top lock nut	38	90029470	1	3/16 x 7/8 Roll pin
14	90006145	4	5/8 NC Flange lock nut	39	90001726	4	7/16 x 1/2-2 Carriage bolt
15	20030877	8	Bushing, flanged	40	20032533	1	Double tube clamp
16	20021940	1	Shank mount weld	41	20030994	1	Single tube clamp
17	90001435	2	3/4 NC X 8 Hex bolt	42	90006276	1	1/2 NC Jam nut
18	90001415	2	3/4 NC X 3-1/2 Hex bolt	43	20022048	1	Spring assy.
19	90011035	2	1/2 Flat washer	44	20033905	1	Formed plate
20	90011013	2	1/2 Lock washer	45	90001373	1	5/8 NC X 7 Hex bolt
21	90006009	2	1/2 Hex nut	46	90001255	1	1/2 NC X 6-1/2 Hex bolt
22	20033201	1	Trunnion, threaded	47	90001750	2	1/2 NC X 1-1/4 Carriage bolt
23	20033928	1	Tube, spring holder	48	20033907	1	Shank
24	20022095	1	Gauge wheel mast	49	90001233	2	1/2 X 2-1/2 Hex bolt
25	20021945	1	Screw, depth adj.	50	90006143	2	1/2 NC Flange lock nut
26	90006508	1	5/8 NC Top lock nut	51	20033437	1	1/4 RND X 7/8 UHMW
27	20033871	1	Down pressure spring rod	52	90016237	1	5/16 X 5/16 Socket set screw

NS = Not Shown
AR = As Required

HILLER COMPONENTS

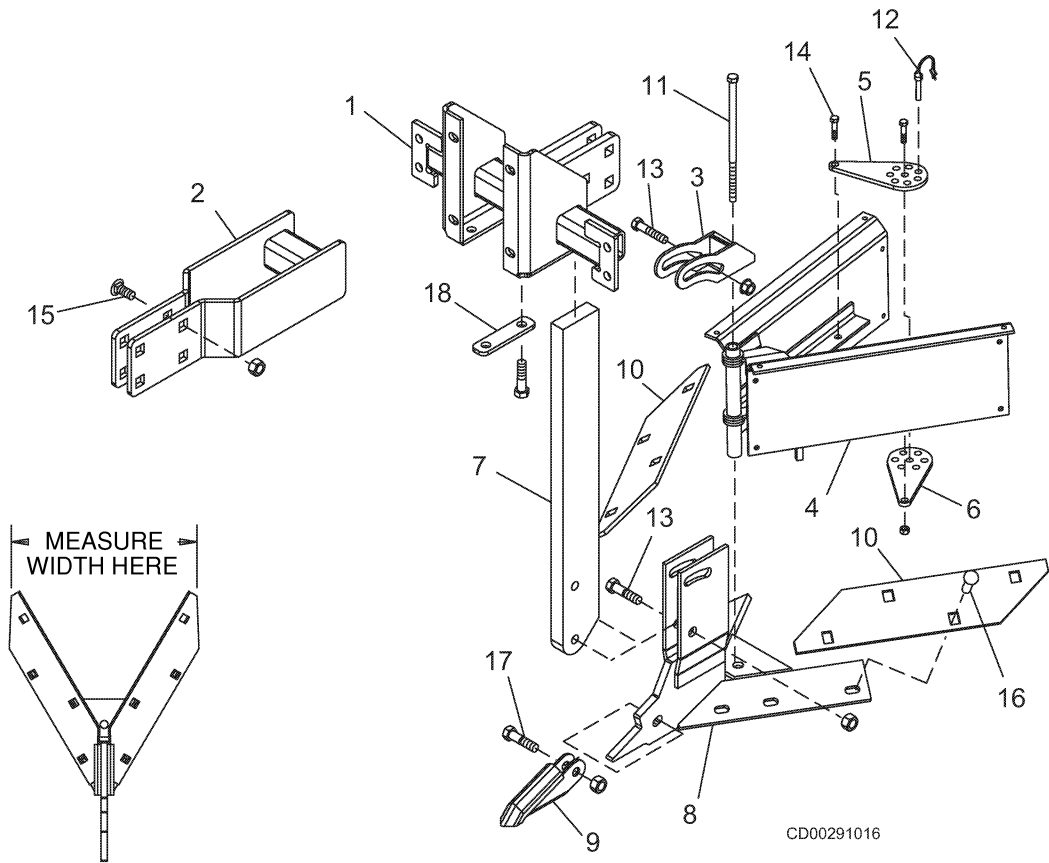

CD00291016

REF	PARTS	QTY	DESCRIPTION	REF	PARTS	QTY	DESCRIPTION
1	20021950	1	Setback weld, 30" rows	10	90510130	2	17" Double edge share
1	20022011	1	Setback weld, 22" rows	10	90510135	2	19" Double edge share
1	20022012	1	Setback weld, 40" rows	10	90510129	2	21" Double edge share
2	20021977	1	Setback weldment	10	90510136	2	25" Double edge share
3	20021982	1	Pivot weldment	11	90001265	1	1/2 NC x 9 Hex bolt GR5
4	20021980	1	Ridger weldment	12	90025028	1	Lock pin
5	20033823	1	Width adjustment plate (7 hole)	13	90001233	1	1/2 NC x 2-1/2 Hex bolt GR5
6	20033817	1	Width adjustment plate (6 hole)	14	90001111	3	3/8 NC x 1-1/4 Hex bolt GR5
7	20031061	1	Ridged shank	15	90006145	4	5/8 NC x 2-1/2 Hex bolt GR5
8	20021917	1	Rigid sweep shoe	16	90001840	4	3/8 NC x 1-1/4 Plow bolt
9	90510128	1	Sweep point	17	90001223	1	1/2 NC x 1-1/2 Hex bolt GR5
				18	20033803	2	Reinforcement plate

80 PARTS

PN-20033738 (Rev. 12/03)

TINE AND ROW GUIDE COMPONENTS

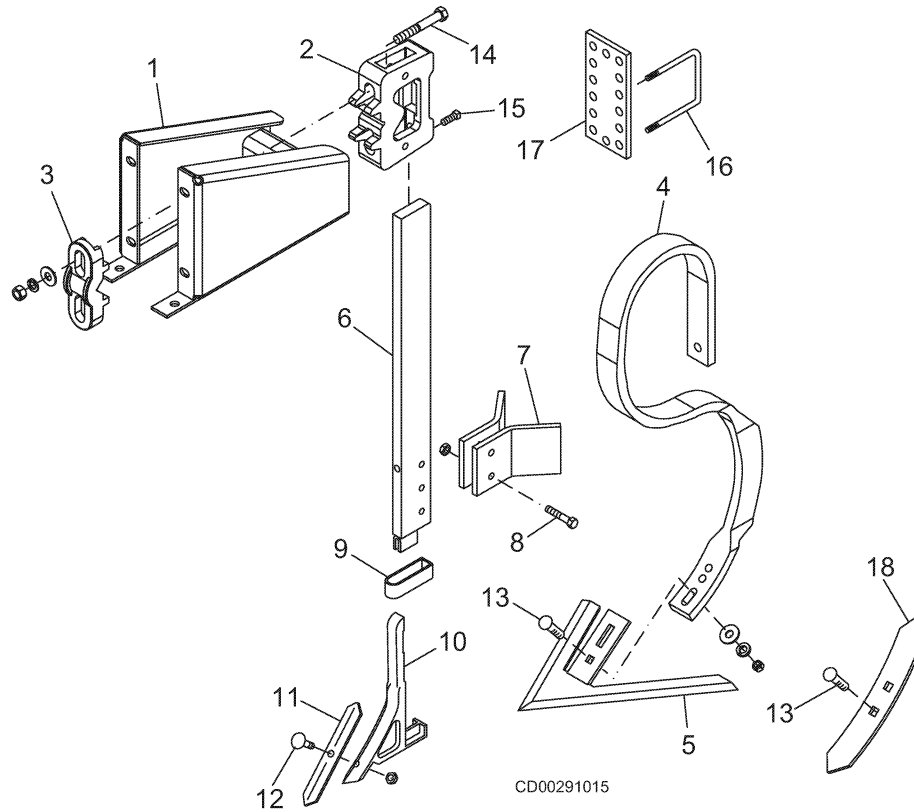

REF	PART	QTY	DESCRIPTION	REF	PART	QTY	DESCRIPTION
1	20021946	1	Setback weld	7	20033294	2	Cleanout wing
2	XXXXXX	1	Clamp body, Order Assy	8	90001117	2	3/8 NC x 2 Hex bolt GR5
3	20031759	1	Clamp back bracket	9	20020607	1	Attachment bracket
3	20021414	1	Clamp assy., 2" square or rectangular, diamond through 2"	10	20031826	1	Row guide point
4	20033524		Tine, heavy duty 20" adj. (5/8)	11	90510088	1	Spike point
4	20033525		Tine, heavy duty 20" adj. (3/4)	12	90001841	1	3/8 NC x 1-1/2 Plow bolt
5	90510114		14" Beet sweep	13	90001902		7/16 NC x 2 Plow bolt
5	90510126		14" Beet sweep, heavy duty	14	90001363	2	5/8 NC x 4-1/2 Hex bolt GR5
5	90510120		20" Beet sweep	15	90016095	2	5/8 NC x 2 Sq. head set screw
6	20020608		Shank, row guide 3/4 x 2-1/2 x 24 long	16	20032856	2	U-Bolt, 1/2 NC x 2-1/2 x 4-1/4
6	20021061		Shank, row guide 3/4 x 2-1/2 x 32 long	17	20032955	2	Plate
				18	905-10018	1	1 3/4" Spike pt
					20020987	1	Assembly Items 10, 11, 12
				NS	20020902		Assembly shank 24"
				NS	20020903		Assembly shank 32"

DUAL DISC & DUAL KNIFE ASSEMBLY

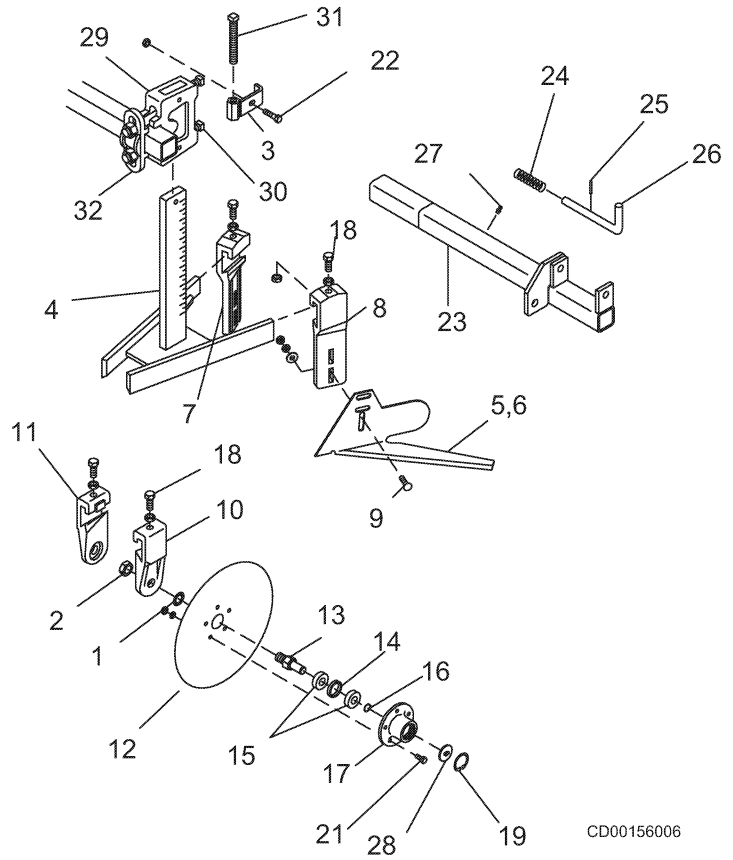

CD00156006

REF	PART	QTY	DESCRIPTION
1	90011190	1	3/4 Internal star washer
2	90006282	1	3/4 NC Jam nut
3	20021418	1	Adjustable nut weld, 3/4 x 2-1/2 shank
4	20021942	1	Shank weld, heavy duty 3/4 x 2-1/2
5	20033684	1	Weeder knife, left short
6	20033685	1	Weeder knife, right short
7	20031251	1	Weeder knife bracket, right
8	20031253	1	Weeder knife bracket, left
9	90001697	2	3/8 x 1-1/2 Carriage bolt
10	20033155		Dual disc bracket, 12° left and right
11	20033155		Dual disc bracket, 12° left and right
12	90510110	2	Disc 14"
13	20031261	1	Axle
14	20031264	1	Spacer
15	90101143	2	Bearing
16	90039029	1	Snap ring 5/8 ID , 3/4 OD x 1/32
17	20033279	1	Hub machined
18	90001225	1	1/2 NC x 1-1/2 Hex bolt GR 5
19	90039048	1	Snap ring
20	90016319	1	5/8NC X 4 Sq. Hex head set screw
21	90001055	1	5/16 NC x 3/4 Hex bolt GR5
22	90001113	1	3/8 NC x 1-1/2 Hex bolt GR5
23	20021695	1	Disc tube weldment 22"-24"
	20021696	1	Disc tube weldment 26"-30"
	20021697	1	Disc tube weldment 36"-40"
24	20032735	1	Spring
25	90029132	1	3/16 x 1-1/4 Roll pin
26	20033184	1	Pin
27	90515013	1	Zerk, 3/16 drive-in

REF	PART	QTY	DESCRIPTION
28	20033278	1	Plastic dust cap
29	20021414	1	Clamp assy. 2" square
30	90016093	2	5/8 NC x 1-1/2 Sq Head set screw
31	90016319	1	3/8 NC x 4-SHSC GR5
32	20031759	1	Clamp bracket back
	20021414	1	Clamp assy. 2" square (Ref 29-32)
	20020694	1	Axle & Bearing assy. (Ref 13-16)
	20020695	1	Hub assy. (Ref 13, 17)
	20021636	1	14" Disc and hub assy.
	20021637	1	14" Disc and adapter assy., 12°
	20021698		Disc mount tube assy. 22"-24" (Ref 23-27)
	20021699		Disc mount tube assy. 26"-30" (Ref 23-27)
	20021700		Disc mount tube assy. 36"-40" (Ref 23-27)
	20021775		Hub assy. (Ref 17, 28, 19)

ADJUSTABLE GUIDE AND SUPPORT WHEELS

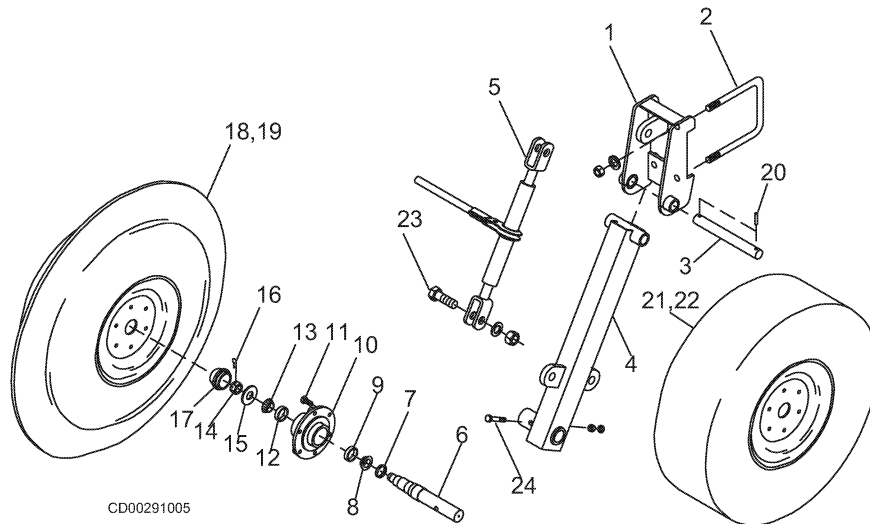

REF	PART	QTY	DESCRIPTION	REF	PART	QTY	DESCRIPTION
1	20020535	1	Mounting bracket	15	90509068	1	1" Washer
2	20030345	2	3/4 U-Bolt	16	90023045	1	Cotter pin, 3/16 x 2"
3	20030896	1	Pin, 1-1/4 x 10-1/8	17	90509009	1	Dust cap
4	20021971	1	Adjustable strut	18	90509019	1	Tire 5.5 x 16 Single rib imp
5	90523009	1	Screw jack	19	90509014	1	Rim 16 x 6LB, 6 bolt
6	20031784	1	Spindle	20	90029204	1	Roll pin, 5/16 x 1-5/8"
7	90109002	1	Seal for 1.750 spindle seal area	21	90509077	1	Rim 15" x 6 x 6 hole
8	90101025	1	Bearing cone, inner	22	90509070	1	Tire 9.5L x 15, 8 ply
9	90101024	1	Bearing cup, inner	23	90001519	2	1 NC x 3 Hex bolt
10	90509004	1	6 Bolt hub	24	90001237	1	1/2 NC x 3 Hex bolt
11	90509010	6	Wheel bolt 1/2 NF x 1-1/16	—	20020931	—	6-Bolt hub assy. (Ref 7-13, 17)
12	90101016	1	Bearing cup, outer	—	20020531	—	7-Bolt hub and spindle assy. (Ref 6-17)
13	90101015	1	Bearing cone, outer	—	20020988	—	Wheel assy., single rib (Ref 18, 19)
14	90006062	1	1" NF Slotted nut				

FLOATING DUAL DISC ASSY

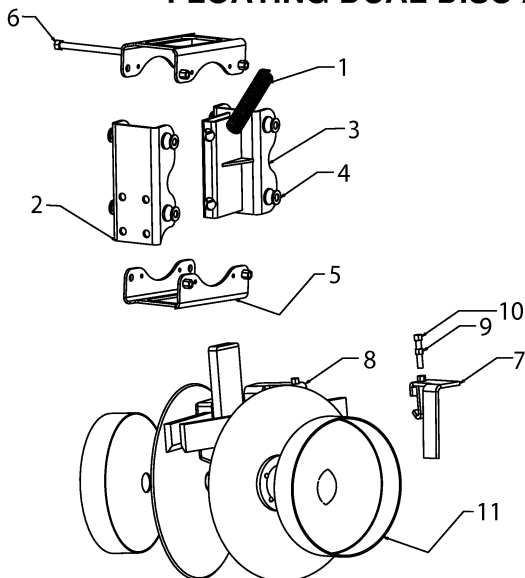

1	20034136	2	Spring
2	20022134	1	Weld, pivot plate
3	20022135	1	Weld, back plate
4	20032913	8	Bushing
5	20022137	2	Weld, link pivot
6	90001201	4	7/16 NC x 5.5" HHCS, ZP
7	20022138	1	Weld, scraper LH
8	20022139	1	Weld, scraper RH
9	90006270	2	3/8 NC jam nut
10	90001111	2	3/8 x 1 1/4 NC HHCS
11	20022140	2	Depth band
NS	90006143	4	1/2 Spiralock nut
NS	90016063	2	1/2 NC x 1-1/4 SQ HD Set screw
NS	90006009	2	1/2 NC Hex nut ZP
NS	90030801	2	1/2 NC Hex nut ZP

SEMI-PNEUMATIC GUIDE WHEEL & STEEL GUIDE WHEEL

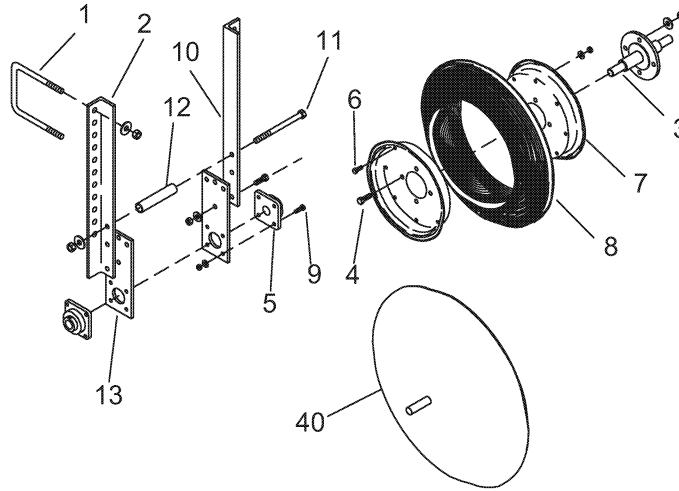

REF	PART	QTY	DESCRIPTION	REF	PARTS	QTY	DESCRIPTION
1	20030344	2	5/8 U-Bolt, 7" inside x 8-1/2 long	9	90001113	8	3/8 NC x 1-1/2 Hex bolt GR5
2	20033858	1	Right angle, 32-1/4 long	10	20033859	1	Left angle, 32-1/4 long
3	20021615	1	Hub	11	90001377	1	5/8 NC x 8 Hex bolt GR5
4	90001225	8	1/2 NC x 1-1/2 Hex bolt GR5	12	20032758	1	Spacer tube
5	90101004	2	1" Bearing, 2-3/4 bolt spacing	13	20032815	2	Bearing plate, 2-3/4 bolt spacing
6	90001109	8	3/8 NC x 1 Hex bolt GR5	—	20020536	1	Wheel and tire assy. (Ref 6, 7, 8)
7	20030891	2	Rim half, 4 x 20	40	20022094	1	Steel Wheel assy., welded (Ref 9-15)
8	90509054	1	V-type tire, 4.5 x 20				

ROW WEEDER DISCS

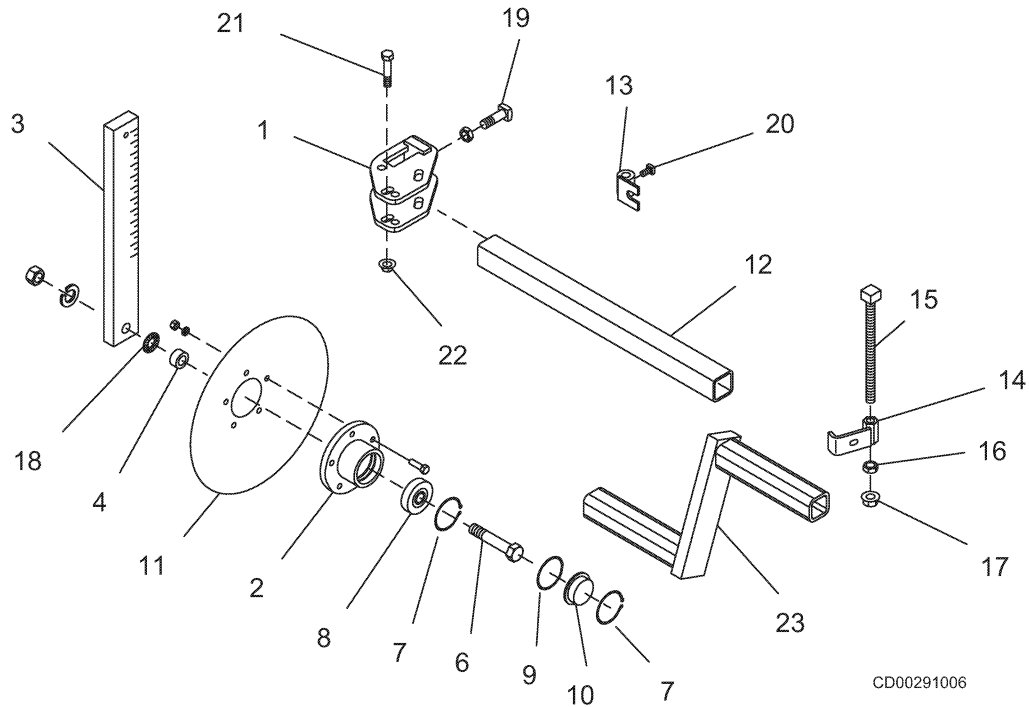

CD00291006

REF	PART	QTY	DESCRIPTION	REF	PARTS	QTY	DESCRIPTION
1	20021876	2	Clamp weldment	13	20021877	1	Nozzle bracket
2	20021466	2	Hub	14	20021418	1	Adjustment nut
3	20032704	2	Shank	15	90016319	2	5/8 NC x 4 Adj. sq. head set screw
4	20032705	2	Spacer	16	90006280	2	5/8 NC Jam nut
5	90001111	10	3/8 NC x 1-1/4 Hex bolt GR5	17	90006145		5/8 NC Whiz nut
6	90001411	2	3/4 NC x 3 Hex Bolts GR5	18	90011190	2	5/8 Internal star washer
7	90039046	2	Snap ring	19	90016095	2	5/8 NC x 2 Sq. head set screw
8	90101254	2	Bearing	20	90016031	2	5/8 NC x 3/4 Sq. head set screw
9	90109206	2	O-Ring	21	90001241	3	1/2 NC x 3-1/2 Hex bolt GR5
10	90509118	2	Dust cap	22	90006143	3	1/2 NC Flange nut
11	90510080	2	Disc	23	20022090	2	Raised bed mount tubes, 30" rows
12	20033576	2	Tube 40" rows, 24" long	23	20022104	2	Raised bed mount tubes, 40" rows
12	20030993	2	Tube 30" rows, 20" long				
12	20033790	2	Tube, dummy, 9" long				

COULTER (STRAIGHT EDGE TINE)

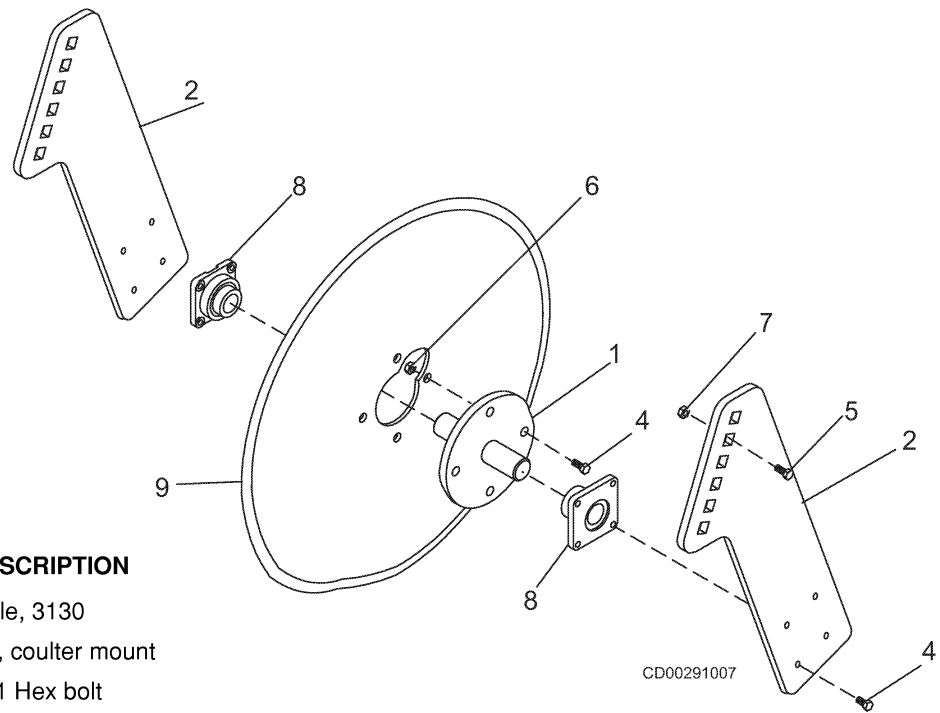

REF	PART	QTY	DESCRIPTION
1	20022097	1	Coultter axle, 3130
2	20033935	2	Side plate, coultter mount
3	90001109	4	3/8 NC X 1 Hex bolt
4	90001113	8	3/8 NC X 1-1/2 Hex bolt
5	90001750	4	1/2 NC X 1-1/4 Carriage bolt
6	90006139	12	3/8 NC Flange whiz lock
7	90006143	4	1/2 NC Spiral lock flange
8	90101004	2	1" 4 Bolt bearing NANF
8	90101003		1" Bearing insert
9	90510079	1	Coultter guide disc

COULTER (RIGID SHANK)

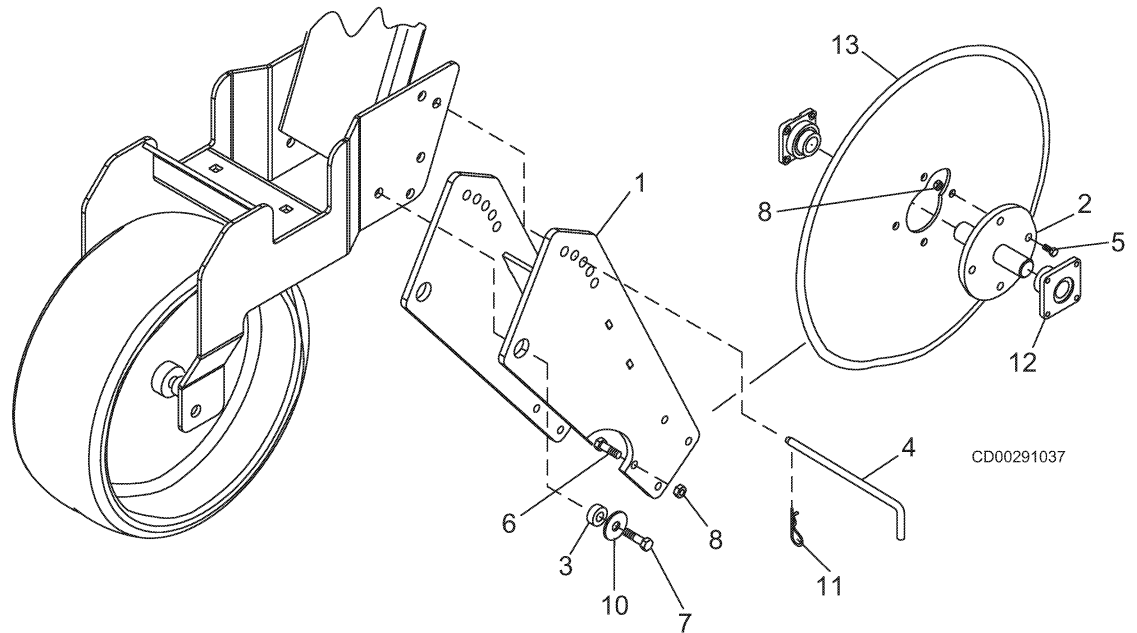

CD00291037

REF	PART	QTY	DESCRIPTION
1	20022096	1	Coulter disc mast
2	20022097	1	Coulter axle
3	20033969	2	Coulter pivot bushing
4	20033970	1	Coulter adjust pin
5	90001109	4	3/8 NC x 1 Hex bolt GR5
6	90001113	8	3/8 NC x 1-1/2 Hex bolt
7	90001225	2	1/2 NC x 1-1/2 Hex bolt
8	90006139	12	3/8 NC Flange whiz lock nut
9	90006143	2	1/2 NC Spirallock flange
10	90011035	2	1/2 Flat washer ZP
11	90025005	1	5/32 Hair pin cotter
12	90101004	2	1" 4-Bolt bearing NANF
NS	90101003	2	1" Bearing insert
13	90510079	1	Disc, guide coulter

COULTER (STABILIZING)

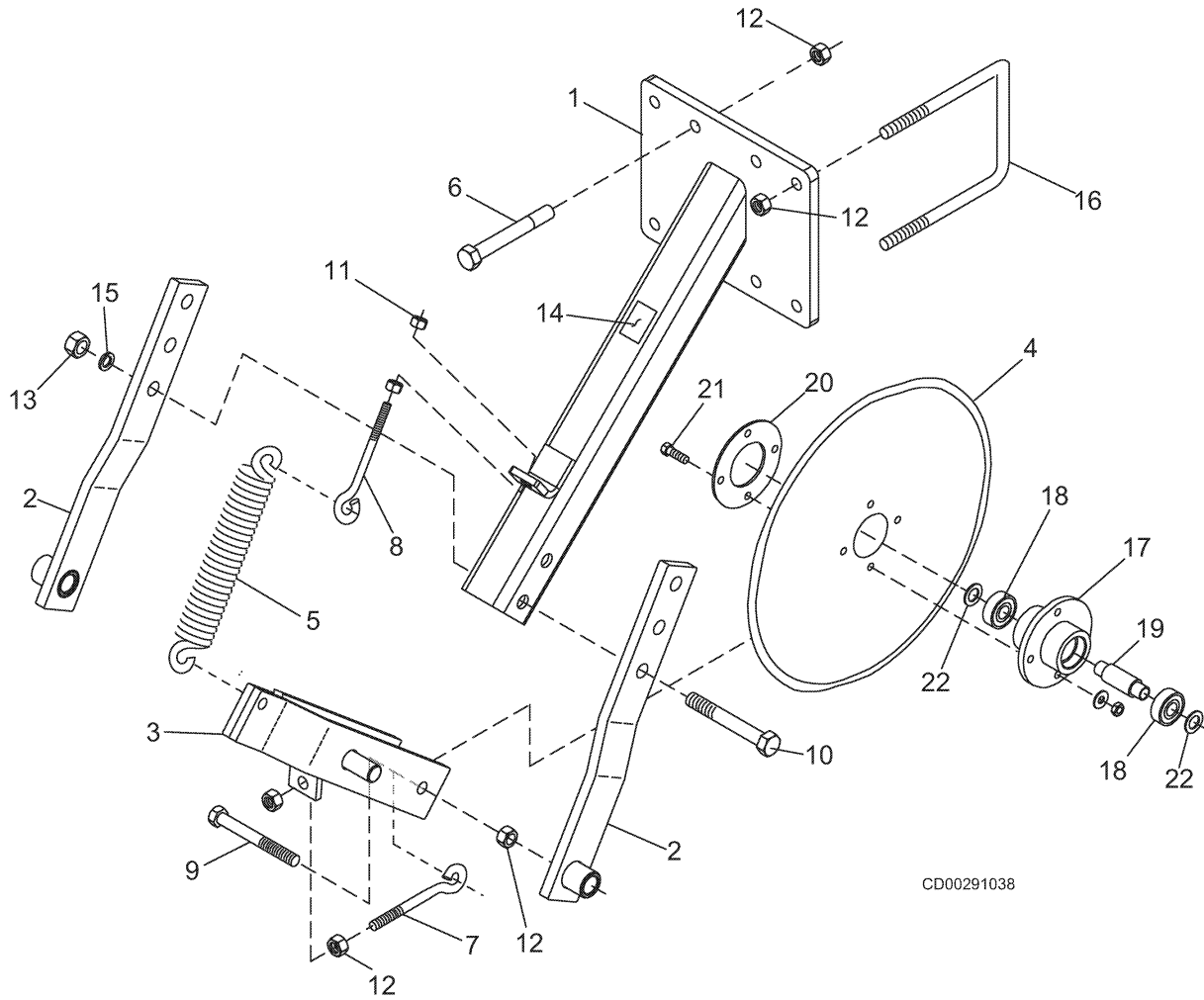

CD00291038

REF	PART	QTY	DESCRIPTION	REF	PART	QTY	DESCRIPTION
1	20022093	1	Stab coultter mast, 3130	12	90006145	7	5/8 NC Hex nut spiral lock
2	20020425	2	Side arm	13	90006015	2	3/4 NC Hex nut
3	20020426	1	Clevis	14	20030193	1	Decal, coultter adjust
4	90510079	1	Disc Blade	15	90011017	2	3/4 Lock washer
5	20033010	1	Spring	16	20030344	2	5/8 NC x 7" U-Bolt
6	90001381	4	5/8 NC x 9 Hex bolt	17	20021772	1	Hub
7	20031285	1	5/8 Eye bolt	18	90101278	2	Bearing
8	10030148	1	1/2 NC Eye bolt	19	20033351	1	Bearing spacer
9	90001369	1	5/8 NC x 6 Hex bolt	20	20030685	1	Back plate
10	90001425	2	3/4 NC x 5-1/2 Hex bolt	21	90001111	4	3/8 NC x 1-1/4 Hex bolt
11	90006009	2	1/2 NC Hex nut ZP	22	90011060	2	3/4 X 14 GA NAR rim machine bushing

COULTER (REAR STABILIZER)

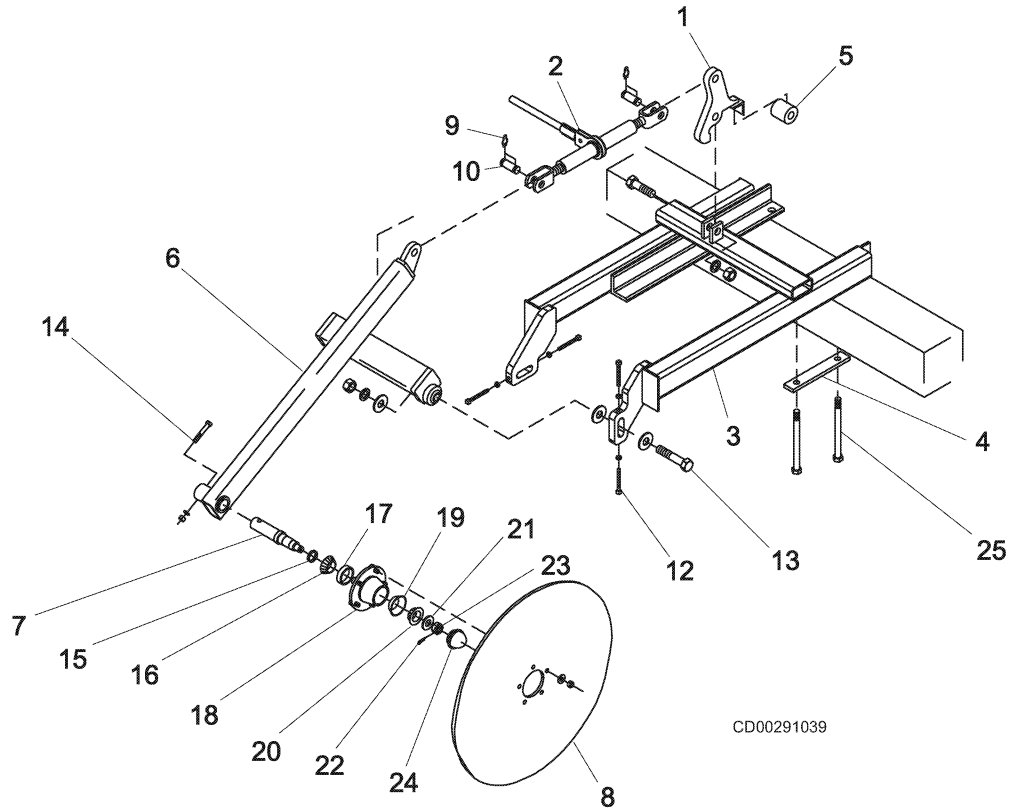

REF	PART	QTY	DESCRIPTION	REF	PART	QTY	DESCRIPTION
1	20020709	1	Arm weldment	16	90101023	1	Bearing cone
2	20020705	1	Ratchet jack	17	90101022	1	Bearing cup, inner
3	20022024	1	Mounting frame, 3130	18	90509003	1	5-Bolt hub with cups
4	20030970	1	Backing strap	19	90101016	1	Bearing cup, outer
5	20031313	1	Rubber bushing	20	90101015	1	Bearing cone
6	20022025	1	Strut, 3130	21	90509067	1	Washer 7/8 x 2
7	20031314	1	Spindle	22	90023043	1	Cotter pin 3/16 x 1-1/2
8	20020707	1	Disc coultter	23	90006060	1	7/8 NF Slotted hex nut
9	90025018	1	3/4 Ext Hair pin clip	24	90509009	1	Dust cap
10	90042048	2	1 x 2-3/4 Clevis pin	25	90006017	4	7/8 NC x 10 Hex bolt GR5
11	90002914	1	1 NC x 3-1/2 Hex bolt GR5	—	20020710	—	Hub and spindle assy. (Ref. 7, 15-24)
12	90016042	4	3/8 x 3-1/2 Sq head set screw	—	10021051	—	Hub assy. (Ref. 15-24)
13	90001531	2	1 NC x 5 Hex bolt GR5				
14	90001237	1	1/2 NC x 3 Hex bolt GR5				
15	90109002	1	Seal for 1.75 spindle seal area, std				
15	90109209	1	Seal for undersized 1.70 seal area				

LIFT ASSIST

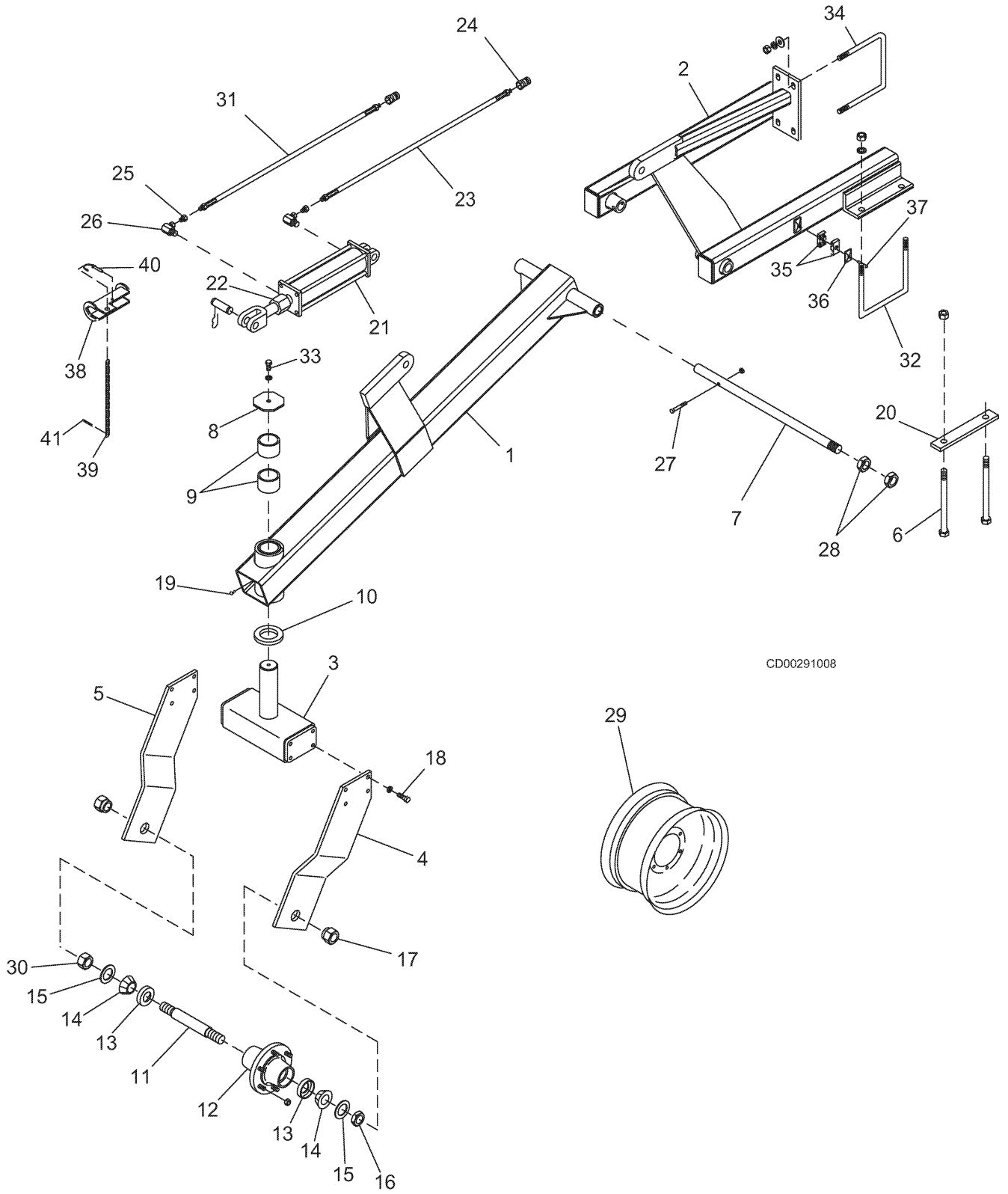

CD00291008

90 PARTS

PN-20033738 (Rev. 12/03)

LIFT ASSIST PARTS LIST

REF	PART	QTY	DESCRIPTION	REF	PART	QTY	DESCRIPTION
1	20021957	1	Tube weldment	20	20033964	2	Strap, Ft reinforced tool bar, 24 row, 3 holes
2	20021955	1	Mount weld, TRF folding toolbars	21	90521391	1	Hydraulic cylinder 3 x 10 stroke
2	20022091	1	Mount weld, flat fold/rigid toolbars	22	90521305	1	Depth stop nut
2	20022101	1	Mount weld, FR folding toolbars, 24 row	23	90519154	1	Hose 6 FJIC x 6 MORB x 115"
3	20020689		Caster pivot weldment	24	90519126	2	Quick coupler, male tip
4	20032622	1	Side plate RH	25	90503162	2	Restrictor 6 MJIC x 8 MORB
5	20032621		Side plate LH	26	90503137	2	Elbow 6 MJIC x 6 FJIC
6	90003039	4	7/8 x 10 Hex bolt	27	90001121	1	3/8 NC x 2-1/2 Hex bolt GR5
7	20032799	1	Pin	28	90006291	2	1-1/4 NF Jam nut
8	20031219	1	Retainer plate	29	90509077	1	6-Hole rim 15" x 6"
9	20031766	2	Bushing	30	90006024	1	1-1/4 NF Hex nut
10	20031233	1	Thrust bearing	31	90519130	1	Hose, 6 FJIC x 6 MORB x 100"
11	20031240	1	Spindle	32	20030345	2	U-Bolt, 3/4 NC x 7" inside x 9-1/8" Ln, Pre '99"
12	90509082	1	Hub with cups	33	90001221	1	1/2 NC x 1 Hex bolt GR5
13	90101148	2	Bearing cup	34	20030344		U-Bolt, 5/8 NC x 7" inside x 8-1/2" long
14	90101149	2	Bearing cone	35	90031069	3	Clamp body
15	90109127	2	Seal	36	90030168	3	Cover plate
16	20032726	1	Nut, short 1-1/4 NF	37	90003459	3	5/16 NC x 1-3/8 Hex bolt GR5
17	20031847	2	1-1/4 NF Shoulder nut	38	20022059	1	Cylinder. stop weld
18	90001225	8	1/2 NC x 1-1/2 Hex bolt GR5	39	12030472	1	Chain
20	20030970	2	Strap	40	90042055	1	Lock pin
19	90515024	1	1/4-28 UNF Straight zer k	41	90023043	4	Cotter pin

OPEN TOP SHIELDS

REF	PART	QTY	DESCRIPTION
1	20021930	1	Shield weldment (LH)
NS	20021929	1	Shield weldment (RH)
2	20033688	1	Guide shield
3	20033519	2	Parallel arm 20-1/2
4	20022013	1	Bracket, 22" rows (RH)
4	20022110	1	Bracket, 30" rows (RH)
4	20022115	1	Bracket, 40" rows (RH)
NS	20022014	1	Bracket Weld, 22 rows (LH)
NS	20022009	1	Bracket, 30" rows (LH)
NS	20022016	1	Bracket, 40" rows (LH)
5	90001173	6	7/16 NC x 1-1/4 Hex bolt
6	90025004	2	1/8 Hair pin cotter
7	20032964	2	Chain
8	90032026	2	3/8 x 2-3/4 Clevis pin
9	90001179	2	7/16 NC x 2 Hex bolt
10	90001647	4	1/4 NC x 3/4 Carriage bolt
11	20033238	2	Shield extension

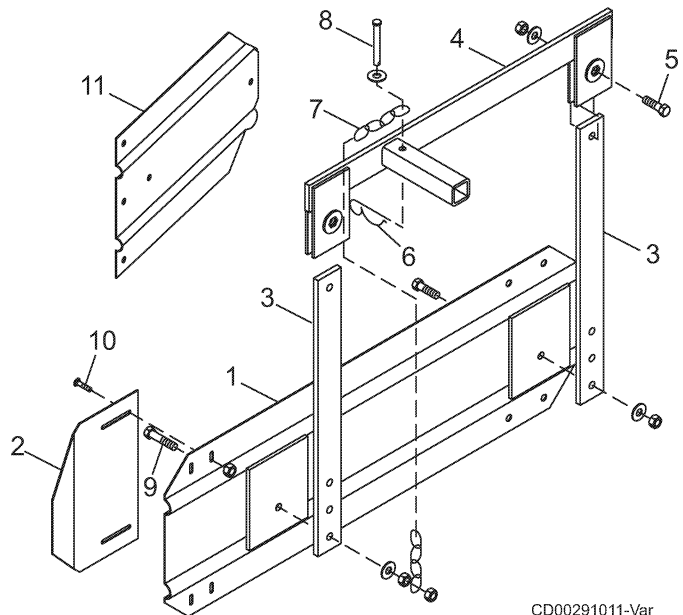

CD00291011-Var

ROLLING SHIELDS

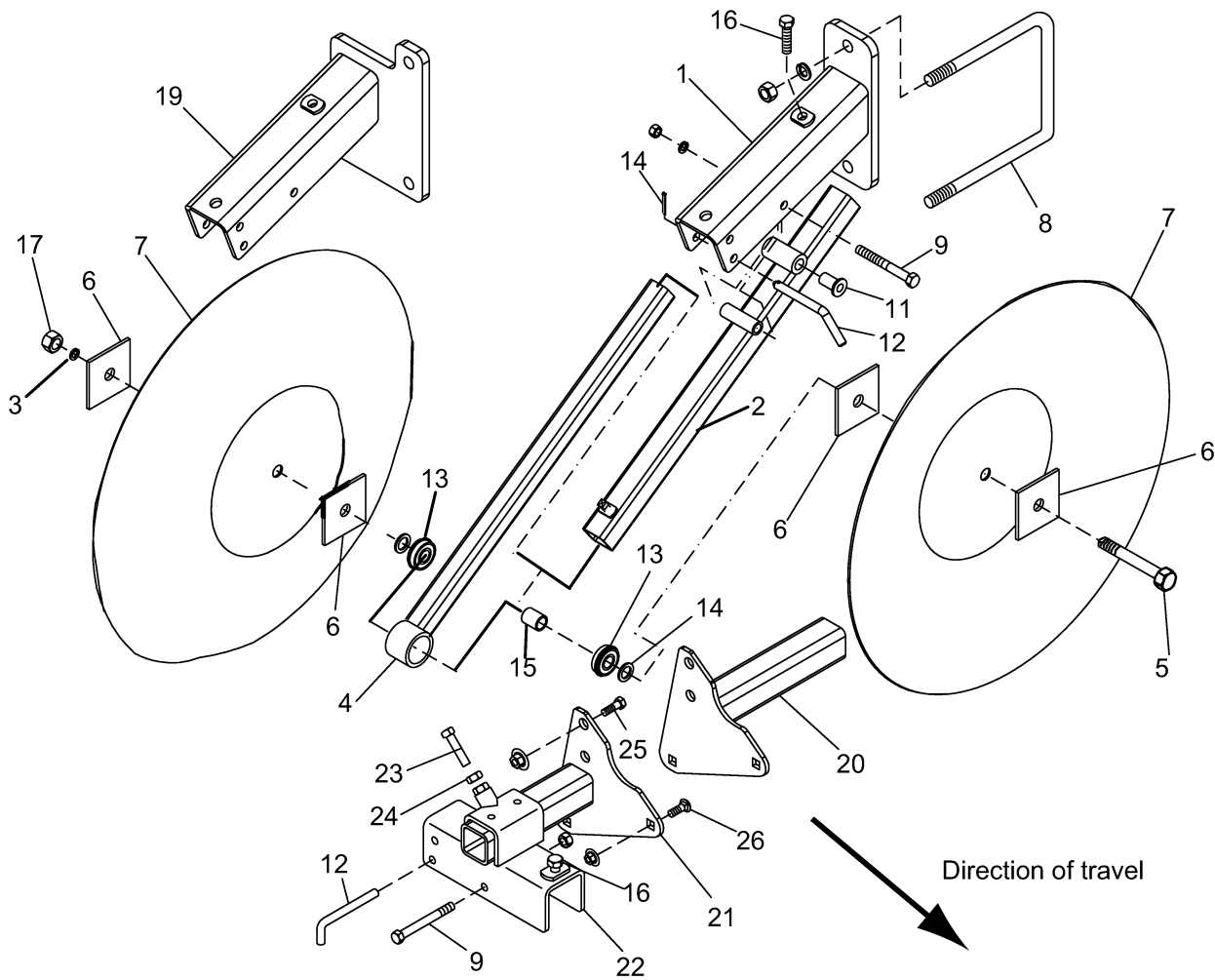

REF	PART	QTY	DESCRIPTION	REF	PART	QTY	DESCRIPTION
1	20021949	1	Rolling shield mount weld	17	90006013	1	5/8 NC Hex nut
2	20021816	1	Rolling shield tube	18			
3	90011015	1	5/8" lock washer	19	20021975	1	Mount offset LH
4	20021714	1	Axle weldment	NS	20021976	1	Mount offset RH
5	90006013	1	Axle (double rolling shield) bolt	20	20022123	1	Mount shield, 3130 LH 22" rows
NS	90001349	1	Axle (single rolling shield) bolt	20	20022026	2	Mount shield, 3130 LH 30" rows
6	20033326	4	Spacer plate	20	20022057	2	Mount shield, 3130 LH 40" rows
7	20033305	2	Disc, 24"	21	20022122	1	Mount shield, 3130 RH 22" rows
8	20030344	1	U-Bolt, 5/8 NC x 7 x 8-1/2" long	21	20022027	1	Mount shield, 3130 RH 30" rows
9	90001195	1	7/16 NC x 4 Hex bolt GR5	21	20022056	1	Mount shield, 3130 RH 40" rows
10				22	20021815	1	Rolling shield bracket
11	20032913	2	Bushing	23	90016064	1	1/2 NC x 1-1/2 Sq. head set screw
12	20033705	1	7/16 x 3 Bent pin	24	90006276	1	1/2 NC Jam nut
13	90101334	2	Bearing	25	90001339	1	5/8 NC x 1-1/4 Hex bolt
14	20033508	2	Washer	26	90001749	2	1/2 NC x 1 Carriage bolt
15	20034138	1	Spacer				
16	90003454	1	1/2 NC x 3 Full thread bolt GR5				

NS = Not Shown

PARKING STANDS

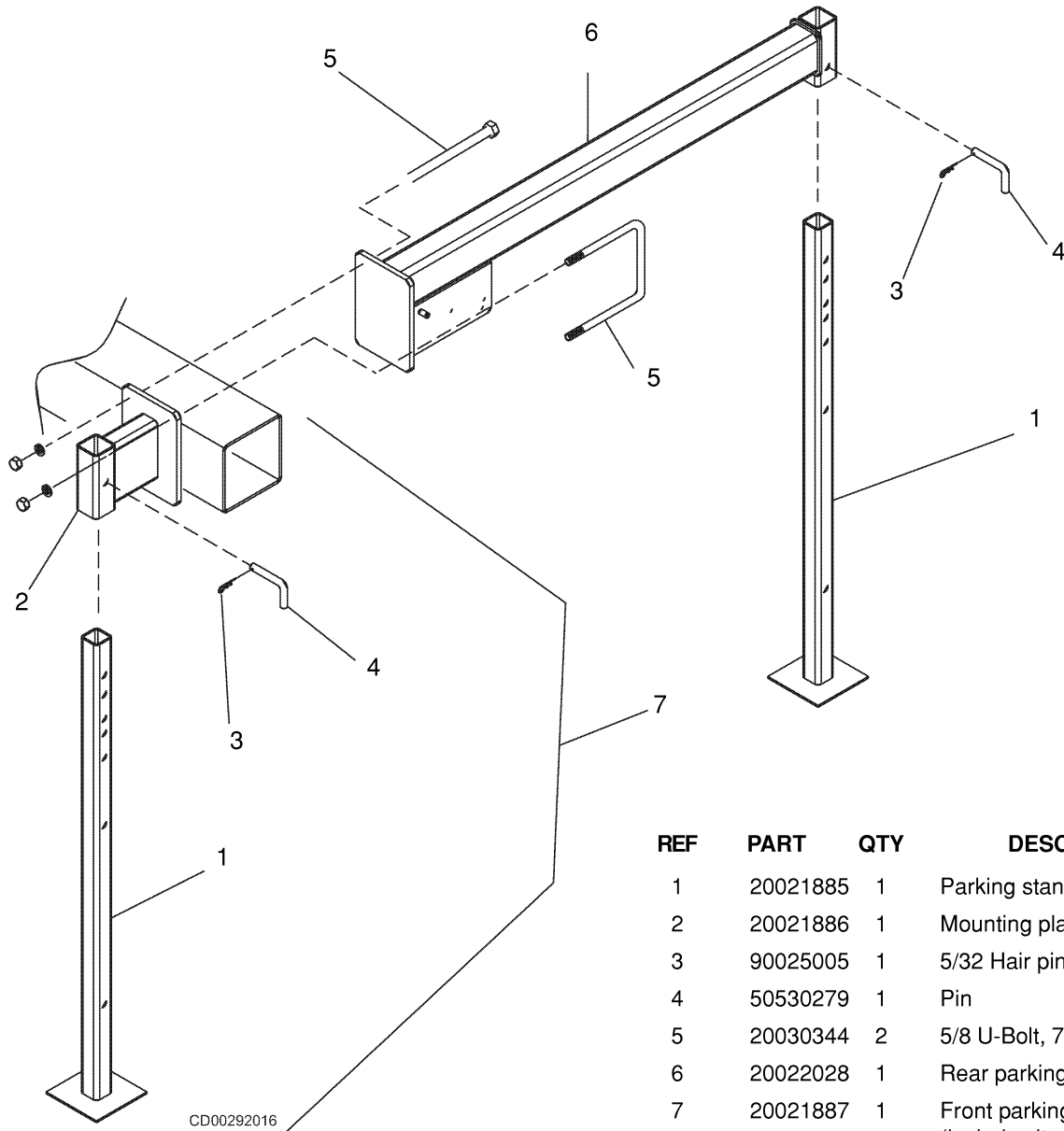

CD00292016

REF	PART	QTY	DESCRIPTION
1	20021885	1	Parking stand
2	20021886	1	Mounting plate
3	90025005	1	5/32 Hair pin cotter
4	50530279	1	Pin
5	20030344	2	5/8 U-Bolt, 7" inside, 8-1/2" long
6	20022028	1	Rear parking stand extension
7	20021887	1	Front parking stand assembly (includes items 1, 2, 3, 4)

BOLT TORQUE CHART

Always tighten hardware to these values unless a different torque value or tightening procedure is listed for a specific application.

Fasteners must always be replaced with the same grade as specified in the manual parts list.

Always use the proper tool for tightening hardware: SAE for SAE hardware and Metric for metric hardware.

Make sure fastener threads are clean and you start thread engagement properly.

All torque values are given to specifications used on hardware defined by SAE J1701 & J1701M JUL96.

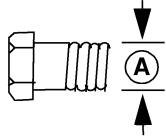

SAE SERIES TORQUE CHART

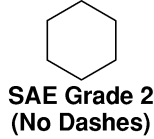

SAE Bolt Head Identification



SAE Grade 5
(3 Radial Dashes)



SAE Grade 8
(6 Radial Dashes)

A Diameter (Inches)	Wrench Size	MARKING ON HEAD					
		SAE 2		SAE 5		SAE 8	
		Lbs.-Ft.	N-m	Lbs.-Ft.	N-m	Lbs.-Ft.	N-m
1/4"	7/16"	6	8	10	13	14	18
5/16"	1/2"	12	17	19	26	27	37
3/8"	9/16"	23	31	35	47	49	67
7/16"	5/8"	36	48	55	75	78	106
1/2"	3/4"	55	75	85	115	120	163
9/16"	13/16"	78	106	121	164	171	232
5/8"	15/16"	110	149	170	230	240	325
3/4"	1-1/8"	192	261	297	403	420	569
7/8"	1-15/16"	306	416	474	642	669	907
1"	1-1/2"	467	634	722	979	1020	1383

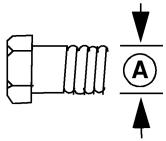

METRIC SERIES TORQUE CHART

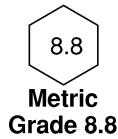

Metric Bolt Head Identification



A Diameter & Thread Pitch (Millimeters)	Wrench Size	COARSE THREAD				FINE THREAD				A Diameter & Thread Pitch (Millimeters)
		MARKING ON HEAD				MARKING ON HEAD				
		Metric 8.8		Metric 10.9		Metric 8.8		Metric 10.9		
		N-m	Lbs.-Ft.	N-m	Lbs.-Ft.	N-m	Lbs.-Ft.	N-m	Lbs.-Ft.	
6 x 1.0	10 mm	8	6	11	8	8	6	11	8	6 x 1.0
8 x 1.25	13 mm	20	15	27	20	21	16	29	22	8 x 1.0
10 x 1.5	16 mm	39	29	54	40	41	30	57	42	10 x 1.25
12 x 1.75	18 mm	68	50	94	70	75	55	103	76	12 x 1.25
14 x 2.0	21 mm	109	80	151	111	118	87	163	120	14 x 1.5
16 x 2.0	24 mm	169	125	234	173	181	133	250	184	16 x 1.5
18 x 2.5	27 mm	234	172	323	239	263	194	363	268	18 x 1.5
20 x 2.5	30 mm	330	244	457	337	367	270	507	374	20 x 1.5
22 x 2.5	34 mm	451	332	623	460	495	365	684	505	22 x 1.5
24 x 3.0	36 mm	571	421	790	583	623	459	861	635	24 x 2.0
30 x 3.0	46 mm	1175	867	1626	1199	1258	928	1740	1283	30 x 2.0

Typical Washer Installations

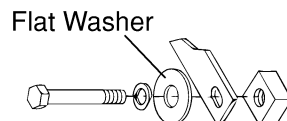
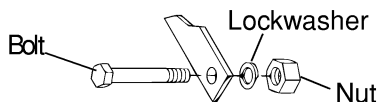

8900

BOLT SIZE CHART

NOTE: Chart shows bolt thread sizes and corresponding head (wrench) sizes for standard SAE and metric bolts.

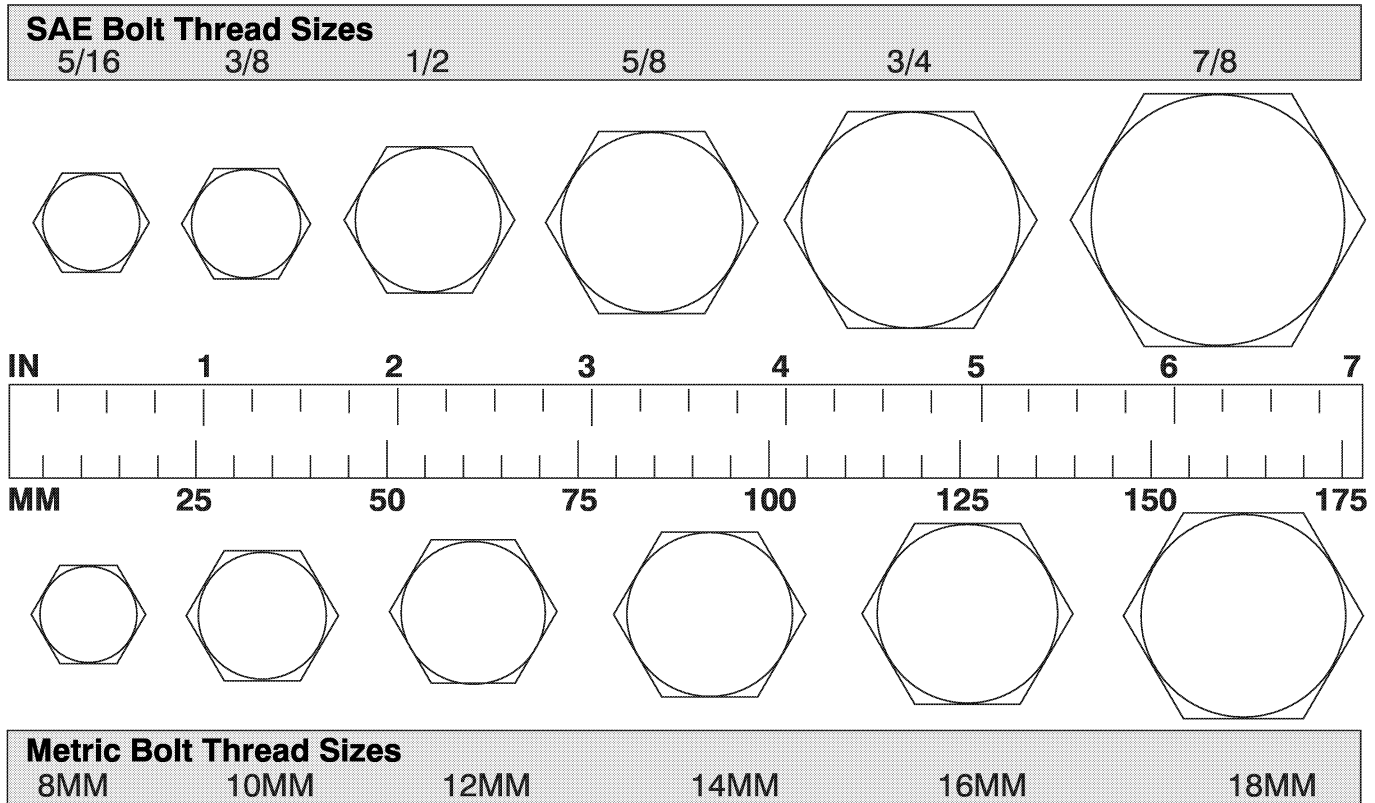

ABBREVIATIONS

AG	Agriculture	NC	National Coarse
ATF	Automatic Transmission Fluid	NF	National Fine
BSPP	British Standard Pipe Parallel	NPSM	National Pipe Straight Mechanical
BSPTM	British Standard Pipe Tapered Male	NPT	National Pipe Tapered
CV	Constant Velocity	NPT SWF	National Pipe Tapered Swivel Female
CCW	Counter-Clockwise	ORBM	O-Ring Boss - Male
CW	Clockwise	P	Pitch
F	Female	PBY	Power Beyond
GA	Gauge	psi	Pounds per Square Inch
GR (5, etc.)	Grade (5, etc.)	PTO	Power Take Off
HHCS	Hex Head Cap Screw	QD	Quick Disconnect
HT	Heat Treated	RH	Right Hand
JIC	Joint Industry Council 37° Degree Flare	ROPS	Roll Over Protective Structure
LH	Left Hand	RPM	Revolutions Per Minute
LT	Left	RT	Right
m	Meter	SAE	Society of Automotive Engineers
mm	Millimeter	UNC	Unified Coarse
M	Male	UNF	Unified Fine
MPa	Mega Pascal	UNS	Unified Special
N	Newton		

INDEX

Assembly

- Adjustable screw kit 58
- Adjustable support wheels
 - Hub and spindle assembly 49
 - Measuring location 52
 - Pivot arm 49
 - Screwjack 49
 - Strut mount 52
 - Tire and rim assembly 49
- Crank 60
- Dealer set-up instructions 33
- Decals 35
- Down pressure springs 46
- Dual disc/Dual knife 57
- Extensions 45
- Final adjustments 41
- Front parking stands 51
- Hiller 61
- Hydraulics 40
- Installing lights 42
- Installing manual storage tube 35
- Installing Pull-type hitch 35
- King guide struts 45
- Lift assist (TRF or TRR bars only) 62
- Mounting hitches 36
 - Identifying toolbar type 36
 - Installing 3-piece mast 37
 - Pull-type hitch 38
- Open top shield 55
- Order of assembly 35
- Preparation 33
- Rear extension with cast clamp 47
- Rear extension with hiller or rigid shank 47
- Rear parking stands 51
- Rear stabilizer coulter 64
- Rolling shields 53
- Row units 42
- Row weeder discs 59
- Semi-pneumatic and steel guide wheels 50
- Shanks 45
- Shovels and sweeps 44
- Tines 43
- Toolbar 39

General

- Abbreviations 95
- Bolt Size Chart 95
- Bolt Torque Chart 94
- General Information 1
- Introduction ii
- Product Warranty *Inside back cover*
- Replacement Parts Warranty *Back cover*
- Safety & Instructional Decals 7
- Specifications 2
- Table of Contents 1

Operation

- Adjustments 27, 28
 - Dual discs 29
 - Gangs 27
 - Leveling toolbar wings 26
 - Optional Equipment (see Assembly)) 29
 - Support wheels 28
 - Center frame support wheels 28
 - Wing support wheels 28
 - Sweeps 29
- Attaching cultivator
 - Pull-type hitch 13
 - Quick hitch 14
 - Standard hitch 17
- Electrical system 21
- Field Operation 24
- Folding the cultivator 22
- Front parking stands 22
- Lift assist 23
- Pre-Operation Check List 12
- Rear parking stands 22
- Removing cultivator 19
 - Pull-type hitch 16
 - Rigid cultivators 18
 - Wing cultivators equipped with lift assist wheels 20
 - Wing cultivators removed in operating position (wings folded) 19
 - Wing cultivators removed in operating position (wings unfolded) 18
- Storage 25
- Transporting cultivator 26
- Unfolding the cultivator 23

Parts

- Index to Parts Lists 65

Safety

- Check Lists
 - Delivery 34
 - Pre-Delivery 34
 - Pre-Operation 12
- Safety Symbols explained ii
- Safety Rules 4
- Transporting cultivator 25

Service & Maintenance

- Greasing 30
 - Storing lubricants 30
- Servicing intervals 31

WARRANTY

Please Enter Information Below and Save For Future Reference.

Date Purchased: _____ From (Dealer): _____

Model Number: _____ Serial Number: _____

ALLOWAY STANDARD, d/b/a ALLOWAY, warrants this product to be free from defect in material and workmanship for TWELVE (12) MONTHS COMMENCING ON THE DATE OF DELIVERY OF THE PRODUCT TO THE ORIGINAL PURCHASER.

Under no circumstances will this Warranty apply in the event that the product, in the good faith opinion of ALLOWAY, has been subjected to improper operation, improper maintenance, misuse, or an accident. This Warranty does not apply in the event that the product has been materially modified or repaired by someone other than ALLOWAY, a ALLOWAY authorized dealer or distributor, and/or a ALLOWAY authorized service center; This Warranty does not cover normal wear or tear, or normal maintenance items. This Warranty also does not cover repairs made with parts other than those obtainable through ALLOWAY.

This Warranty is extended solely to the original purchaser of the product. Should the original purchaser sell or otherwise transfer this product to a third party, this Warranty does not transfer to the third party purchaser in any way. There are no third party beneficiaries of this Warranty.

ALLOWAY makes no warranty, express or implied, with respect to tires or other parts or accessories not manufactured by ALLOWAY. Their respective manufacturers, if any, provide warranties for these items, separately. ALLOWAYS' obligation under this Warranty is limited to, at ALLOWAYS' option, the repair or replacement, free of charge, of the product if ALLOWAY, in its sole discretion, deems it to be defective or in noncompliance with this Warranty. The product must be returned to ALLOWAY with proof of purchase within thirty (30) days after such defect or noncompliance is discovered or should have been discovered, routed through the dealer and distributor from whom the purchase was made, transportation charges prepaid. ALLOWAY shall complete such repair or replacement within a reasonable time after ALLOWAY receives the product. THERE ARE NO OTHER REMEDIES UNDER THIS WARRANTY. THE REMEDY OF REPAIR OR REPLACEMENT IS THE SOLE AND EXCLUSIVE REMEDY UNDER THIS WARRANTY.

THERE ARE NO WARRANTIES, WHICH EXTEND BEYOND THE DESCRIPTION ON THE FACE OF THIS WARRANTY. ALLOWAY MAKES NO OTHER WARRANTY, EXPRESS OR IMPLIED, AND ALLOWAY SPECIFICALLY DISCLAIMS ANY IMPLIED WARRANTY OF MERCHANTABILITY AND/OR ANY IMPLIED WARRANTY OF FITNESS FOR A PARTICULAR PURPOSE.

ALLOWAY shall not be liable for any incidental or consequential losses, damages or expenses, arising directly or indirectly from the product, whether such claim is based upon breach of contract, breach of warranty, negligence, strict liability in tort or any other legal theory. Without limiting the generality of the foregoing. Alloway specifically disclaims any damages relating to (i) lost profits, business, revenues or goodwill; (ii) loss of crops; (iii) loss because of delay in harvesting; (iv) any expense or loss Incurred for labor, supplies, substitute machinery or rental; or (v) any other type of damage to property or economic loss.

This Warranty is subject to any existing conditions of supply, which may directly affect ALLOWAYS' ability to obtain materials or manufacture replacement parts.

No agent, representative, dealer, distributor, serviceperson, salesperson, or employee of any company; including without limitation, ALLOWAY, its authorized dealers, distributors, and service centers, is authorized to alter, modify, or enlarge this Warranty.

This Warranty is effective only if the warranty registration card is returned within ten (10) days.

Answers to any questions regarding warranty service and locations may be obtained by contacting:

Alloway
4230 14th Ave. NW
Fargo, North Dakota 58102
701-356-4983

WARRANTY

ALLOWAY STANDARD, d/b/a ALLOWAY, warrants this product to be free from defect in material and workmanship for a period of ninety (90) days from the date of delivery of the product to the original purchaser.

Under no circumstances will this Warranty apply in the event that the product, in the good faith opinion of ALLOWAY, has been subjected to improper operation, improper maintenance, misuse, or an accident. This Warranty does not cover normal wear or tear, or normal maintenance items.

This Warranty is extended solely to the original purchaser of the product. Should the original purchaser sell or otherwise transfer this product to a third party, this Warranty does not transfer to the third party purchaser in any way. There are no third party beneficiaries of this Warranty.

ALLOWAYS' obligation under this Warranty is limited to, at ALLOWAYS option, the repair or replacement, free of charge, of the product if ALLOWAY, in its sole discretion, deems it, to be defective or in noncompliance with this Warranty. The product must be returned to ALLOWAY with proof of purchase within thirty (30) days after such defect or noncompliance is discovered or should have been discovered, routed through the dealer and distributor from whom the purchase was made, transportation charges prepaid. ALLOWAY shall complete such repair or replacement within a reasonable time after ALLOWAY receives the product. THERE ARE NO OTHER REMEDIES UNDER THIS WARRANTY. THE REMEDY OF REPAIR OR REPLACEMENT IS THE SOLE AND EXCLUSIVE REMEDY UNDER THIS WARRANTY.

THERE ARE NO WARRANTIES WHICH EXTEND BEYOND THE DESCRIPTION ON THE FACE OF THIS WARRANTY. ALLOWAY MAKES NO OTHER WARRANTY, EXPRESS OR IMPLIED, AND ALLOWAY SPECIFICALLY DISCLAIMS ANY IMPLIED WARRANTY OF MERCHANTABILITY AND/OR ANY IMPLIED WARRANTY OF FITNESS FOR A PARTICULAR PURPOSE.

ALLOWAY shall not be liable for any incidental or consequential losses, damages or expenses, arising directly or indirectly from the product, whether such claim is based upon breach of contract, breach, of warranty, negligence, strict liability in tort or any other legal theory. Without limiting the generality of the foregoing, Alloway specifically disclaims any damages relating to (i) lost profits, business, revenues or goodwill; (ii) loss of crops; (iii) loss because of delay in harvesting; (iv) any expense or loss incurred for labor, supplies, substitute machinery or rental; or (v) any other type of damage to property or economic loss.

This Warranty is subject to any existing conditions of supply, which may directly affect ALLOWAYS' ability to obtain materials or manufacture replacement parts.

No agent, representative, dealer, distributor, service person, salesperson, or employee of any company, including without limitation, ALLOWAY, Its authorized dealers, distributors, and service centers, IS authorized to alter, modify, or enlarge this Warranty.

Answers to any questions regarding warranty service and locations may be obtained by contacting:

Alloway
4230 14th Ave. NW
 Fargo, North Dakota 58102
701-356-4983

PART NO.
20033738

ALLOWAY
STANDARD
alloway