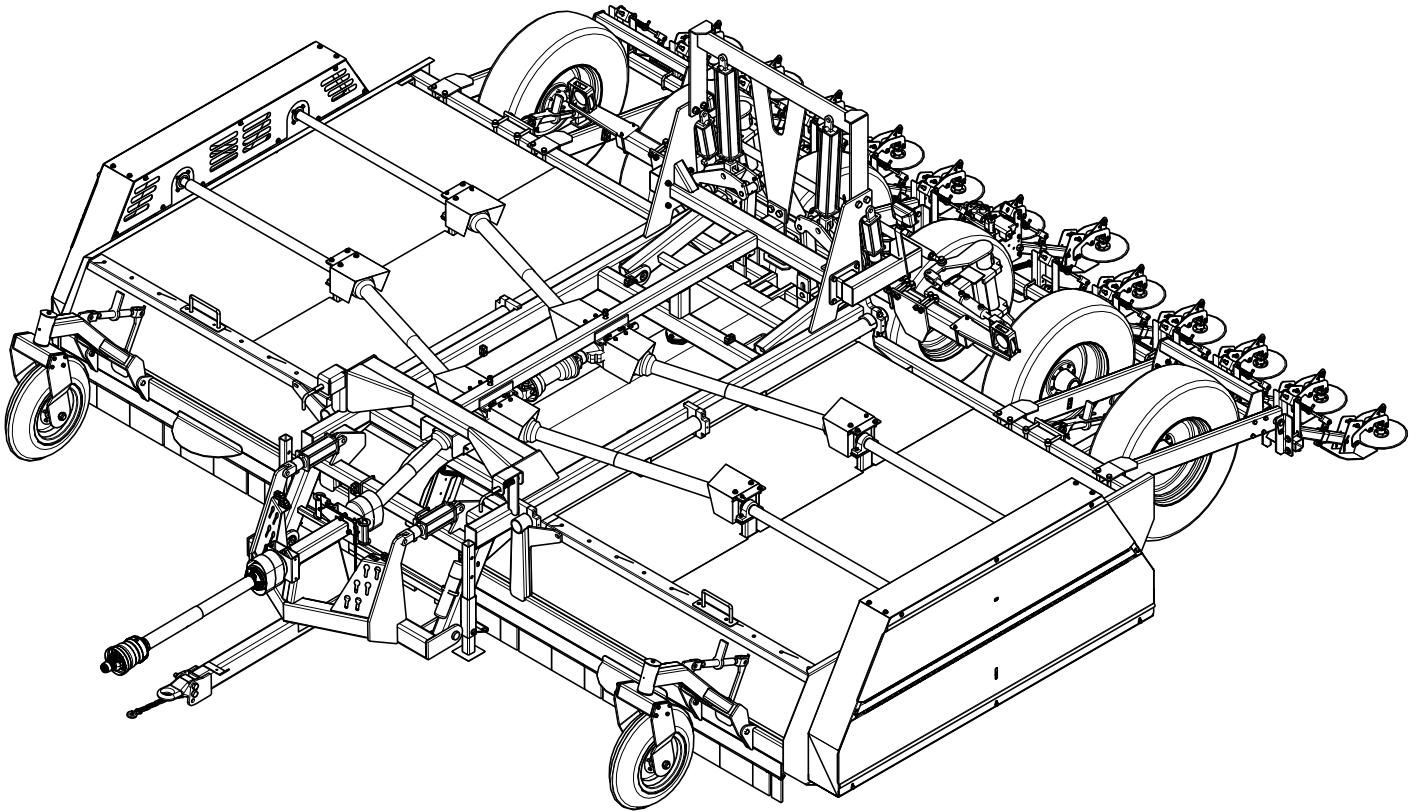


# FOLDING DEFOLIATOR

2013 - 2014

FD 243 (830, 1220)

FD 267 (1222)



SERIAL NUMBER : 3527 - 3672

# OPERATOR'S MANUAL

**TO THE DEALER:**

Assembly and proper installation of this product is the responsibility of the Alloway dealer. Read manual instructions and safety rules. Make sure all items on the Dealer's Pre-Delivery and Delivery Check Lists in the Operator's Manual are completed before releasing equipment to the owner.

The dealer must complete the Warranty Registration included in this manual. Both dealer and customer must sign the registration which certifies that all Dealer Check List items have been completed. The dealer is to return the prepaid postage portion to Alloway, give one copy to the customer, and retain one copy.

**Note: Warranty credit is subject to this form being completed and returned.**

**TO THE OWNER:**

Read this manual before operating your Alloway equipment. The information presented will prepare you to do a better and safer job. Keep this manual handy for ready reference. Require all operators to read this manual carefully and become acquainted with all the adjustment and operating procedures before attempting to operate. Replacement manuals can be obtained from your dealer.

The equipment you have purchased has been carefully engineered and manufactured to provide dependable and satisfactory use. Like all mechanical products, it will require cleaning and upkeep. Lubricate the unit as specified. Observe all safety information in this manual and safety decals on the equipment.

For service, your authorized Alloway dealer has trained mechanics, genuine Alloway service parts, and the necessary tools and equipment to handle all your needs.

Use only genuine Alloway service parts. Substitute parts will void the warranty and may not meet standards required for safe and satisfactory operation. Record the model number and serial number of your equipment in the spaces provided:

**Model:** \_\_\_\_\_ **Date of Purchase** \_\_\_\_\_

**Serial Number: (see Safety Decal section for location)** \_\_\_\_\_

Provide this information to your dealer to obtain correct repair parts.

Throughout this manual, the term **IMPORTANT** is used to indicate that failure to observe can cause damage to equipment. The terms **CAUTION**, **WARNING** and **DANGER** are used in conjunction with the Safety-Alert Symbol, (a triangle with an exclamation mark), to indicate the degree of hazard for items of personal safety.



This Safety-Alert Symbol indicates a hazard and means **ATTENTION! BECOME ALERT! YOUR SAFETY IS INVOLVED!**



Indicates an imminently hazardous situation that, if not avoided, will result in death or serious injury.



**WARNING**

Indicates a potentially hazardous situation that, if not avoided, could result in death or serious injury, and includes hazards that are exposed when guards are removed



**CAUTION**

Indicates a potentially hazardous situation that, if not avoided, may result in minor or moderate injury.

**IMPORTANT**

Indicates that failure to observe can cause damage to equipment.

**NOTE**

Indicates helpful information.



# TABLE OF CONTENTS

INTRODUCTION .....	Inside Front Cover
GENERAL INFORMATION .....	1
SAFETY RULES .....	3 - 7
CHECK LISTS (DEALER'S RESPONSIBILITY) .....	8
OPERATOR SIGN-OFF RECORD .....	9
SAFETY DECALS .....	10 - 13
OPERATION .....	15 - 28
OWNER SERVICE .....	29 - 33
TROUBLE SHOOTING .....	34
INDEX TO PARTS LISTS .....	35
BOLT TORQUE CHART .....	85
ABBREVIATIONS .....	86
INDEX .....	87
REPLACEMENT PARTS WARRANTY .....	88
PRODUCT WARRANTY .....	Inside Back Cover

---

## GENERAL INFORMATION

The purpose of this manual is to assist you in operating and maintaining your Beet Defoliator. Read it carefully. It furnishes information and instructions that will help you achieve years of dependable performance. These instructions have been compiled from extensive field experience and engineering data. Some information may be general in nature due to unknown and varying operating conditions. However, through experience and these instructions, you should be able to develop procedures suitable to your particular situation.

The illustrations and data used in this manual were current at the time of printing, but due to possible inline production changes, your machine may vary slightly in detail. We reserve the right to redesign and change the machines as may be necessary without notification.



### WARNING

- **Some illustrations in this manual show the Beet Defoliator with safety shields removed to provide a better view. The Beet Defoliator should never be operated with any safety shielding removed.**

Throughout this manual, references are made to right and left direction. These are determined by standing behind the equipment facing the direction of forward travel.

# SPECIFICATIONS

Number of Rows: ..... 8 - 12  
Row Spacing: ..... 20 - 30 in (51 - 76 cm)  
Transport Width (Folded): ..... 14' 4" (4.4 m)  
Overall Width (Operation): ..... 25' 6" (7.8 m)  
Transport Height (Folded): ..... 13' 4" (4.1 m)  
Tractor PTO Speed: ..... 1000 RPM  
Tire Size: ..... (Traction Tire) 11.2 X 24  
Tire Pressure: ..... 20 PSI (137.9 kPa)  
Flail Types: ..... Steel (Cup-knife / L-Knife) or Rubber  
Scalper (Rotating Disc Type): ..... Optional  
Weight (Cup-Knife): ..... 14,400 lbs (6530 kg)  
Weight (L-Knife): ..... 13,800 lbs (6260 kg)  
Weight (Rubber Flail): ..... 13,200 lbs (5990 kg)  
Weight (Scalper Attachment): ..... 2,800 lbs (1270 kg)





# SAFETY RULES

## ATTENTION! BECOME ALERT! YOUR SAFETY IS INVOLVED!



Safety is a primary concern in the design and manufacture of our products. Unfortunately, our efforts to provide safe equipment can be wiped out by a single careless act of an operator.

In addition to the design and configuration of equipment, hazard control and accident prevention are dependent upon the awareness, concern, prudence and proper training of personnel involved in the operation, transport, maintenance and storage of equipment.

It has been said "The best safety device is an informed, careful operator." We ask you to be that kind of an operator.

The designed and tested safety of this equipment depends on it being operated within the limitations as explained in this manual.

### TRAINING

- **Safety instructions are important! Read all attachment and power unit manuals; follow all safety rules and safety decal information. (Replacement manuals are available from dealer). Failure to follow instructions or safety rules can result in serious injury or death.**
- **If you do not understand any part of this manual and need assistance, see your dealer.**
- **Know your controls and how to stop engine and attachment quickly in an emergency.**
- **Operators must be instructed in and be capable of the safe operation of the equipment, its attachments and all controls. Do not allow anyone to operate this equipment without proper instructions.**
- **Keep hands and body away from pressurized lines. Use paper or cardboard, not body parts to check for leaks. Wear safety goggles. Hydraulic fluid under pressure can easily penetrate skin and will cause serious injury or death.**
- **Make sure that all operating and service personnel know that in the event hydraulic fluid penetrates skin, it must be surgically removed as soon as possible by a doctor familiar with this form of injury, or gangrene, serious injury or death will result. CONTACT A PHYSICIAN IMMEDIATELY IF FLUID ENTERS SKIN OR EYES. DO NOT DELAY.**

- **Never allow children or untrained persons to operate equipment.**

### PREPARATION

- **Check that all hardware is tight and properly installed. Always tighten to torque chart specifications unless instructed otherwise in this manual.**
- **Air in hydraulic systems can cause erratic operation and allows loads or equipment components to drop unexpectedly. Before operating or allowing anyone to approach the equipment, purge any air in the system by operating all hydraulic functions several times after connecting equipment, connecting hoses, or doing any hydraulic maintenance.**
- **Make sure all hydraulic hoses, fittings and valves are in good condition and not leaking before starting power unit or using equipment. Check and route hoses carefully to prevent damage. Hoses must not be twisted, bent sharply, kinked, frayed, pinched, or come into contact with any moving parts. Operate moveable components through full operational range to check clearances. Replace any damaged hoses immediately.**
- **Always wear relatively tight and belted clothing to avoid entanglement in moving parts. Wear sturdy, rough-soled work shoes and protective equipment for eyes, hair, hands, hearing and head; and respirator or filter mask where appropriate.**
- **Ensure implement is properly attached, adjusted and in good operating condition.**
- **Make sure spring-activated locking pin or collar slides freely and is seated firmly in tractor PTO spline groove.**
- **Before starting power unit, check all equipment driveline guards for damage and make sure they rotate freely on all drivelines. Replace any damaged guards. If guards do not rotate freely on drivelines, repair and replace bearings before operating.**

*(Safety Rules continued on next page)*



# SAFETY RULES

## ATTENTION! BECOME ALERT! YOUR SAFETY IS INVOLVED!



*(Safety Rules continued from previous page)*

■ Power unit must be equipped with ROPS or ROPS CAB and seat belt. Keep seat belt securely fastened. Falling off power unit can result in death from being run over or crushed. Keep foldable ROPS systems in “locked up” position at all times.

■ Connect PTO driveline directly to power unit PTO shaft. Never use adapter sleeves or adapter shafts. Adapters can cause driveline failures due to incorrect spline or incorrect operating length and can result in personal injury or death. ■ Inspect rubber flaps and swing rod before each use. Replace if damaged or missing. Flaps must pivot and hang freely so there are no gaps. Do not put equipment into service until repaired.

■ Remove accumulated debris from this equipment, tractor and engine to avoid fire hazard.

■ Ensure all safety decals are installed. Replace if damaged. (See Safety Decals section for location.)

■ Ensure shields and guards are properly installed and in good condition. Replace if damaged.

■ A minimum 20% of tractor and equipment weight must be on tractor front wheels when attachments are in transport position. Without this weight, tractor could tip over, causing personal injury or death. The weight may be attained with a loader, front wheel weights, ballast in tires or front tractor weights. When attaining the minimum 20% weight on the front wheels, you must not exceed the Roll Over Protection Structure (ROPS) weight certification. Weigh the tractor and equipment. Do not estimate.

■ Make sure hydraulic hoses and cylinders are fully purged of air before operating. Keep all persons away and fill the system by raising and lowering all functions several times. Air in the system can allow components to fall unexpectedly.

■ Inspect and clear area of stones, branches, or other hard objects that might be thrown, causing injury or damage.

## TRANSPORTING

■ Power unit must be equipped with ROPS or ROPS cab and seat belt. Keep seat belt securely fastened. Falling off power unit can result in death from being run over or crushed. Keep foldable ROPS systems in “locked up” position at all times.

■ Always sit in power unit seat when operating controls or starting engine. Securely fasten seat belt, place transmission in neutral, engage brake, and ensure all other controls are disengaged before starting power unit engine.

■ A minimum 20% of tractor and equipment weight must be on the tractor front wheels when attachments are in transport position. Without this weight, tractor could tip over, causing personal injury or death. The weight may be attained with a loader, front wheel weights, ballast in tires or front tractor weights. Weigh the tractor and equipment. Do not estimate.

■ Always attach safety chain to tractor drawbar when transporting unit.

■ Always raise unit and install transport locks before transporting. Leak down or failure of mechanical or hydraulic system can cause equipment to drop.

■ Never exceed 20 MPH during transport. See the Speed vs. Weight Ratio Table in "Field Operation, Transporting the Unit" for proper tow vehicle to machine weight ratios.

■ Watch for hidden hazards on the terrain.

■ Always comply with all state and local lighting and marking requirements.

■ Never allow riders on power unit or attachment.

■ Do not operate PTO during transport.

■ Look down and to the rear and make sure area is clear before operating in reverse.

*(Safety Rules continued on next page)*



# SAFETY RULES

## ATTENTION! BECOME ALERT! YOUR SAFETY IS INVOLVED!



*(Safety Rules continued from previous page)*

- Do not operate or transport on steep slopes.
- Use extreme care and reduce ground speed on slopes and rough terrain.
- Do not operate or transport equipment while under the influence of alcohol or drugs.

---

### OPERATION

- Do not operate or transport equipment while under the influence of alcohol or drugs.
- Equipment may be pictured with covers open for instructional purposes. Never operate equipment with covers open.
- Do not allow bystanders in the area when operating, attaching, removing, assembling, or servicing equipment.
- Do not allow anyone to stand between tractor and unit when backing up to unit.
- Never go underneath equipment (lowered to the ground or raised) unless it is properly blocked and secured. Never place any part of the body underneath equipment or between moveable parts even when the engine has been turned off. Hydraulic system leak down, hydraulic system failures, mechanical failures, or movement of control levers can cause equipment to drop or rotate unexpectedly and cause severe injury or death. Follow Operator's Manual instructions for working underneath and blocking requirements or have work done by a qualified dealer.
- Keep bystanders away from equipment.
- Do not operate or transport equipment while under the influence of alcohol or drugs.
- Operate only in daylight or good artificial light.
- Avoid contact with electrical wires.
- Keep hands, feet, hair, and clothing away from equipment while engine is running. Stay clear of all moving parts.

- Always comply with all state and local lighting and marking requirements.
- Never allow riders on power unit or attachment.
- Power unit must be equipped with ROPS or ROPS cab and seat belt. Keep seat belt securely fastened. Falling off power unit can result in death from being run over or crushed. Keep foldable ROPS systems in "locked up" position at all times.
- Always sit in power unit seat when operating controls or starting engine. Securely fasten seat belt, place transmission in neutral, engage brake, and ensure all other controls are disengaged before starting power unit engine.
- Operate tractor PTO at the RPM speed stated in "Specifications" section.
- Do not operate PTO during transport.
- Look down and to the rear and make sure area is clear before operating in reverse.
- Do not operate or transport on steep slopes.
- Do not stop, start, or change directions suddenly on slopes.
- Use extreme care and reduce ground speed on slopes and rough terrain.
- Watch for hidden hazards on the terrain during operation.
- Stop power unit and equipment immediately upon striking an obstruction. Turn off engine, remove key, inspect, and repair any damage before resuming operation.
- Never work on scalper attachment in the raised position. Lower scalpings to the ground and service each unit individually.
- Always raise scalper arms before going in reverse.
- Always connect safety chain from equipment to towing vehicle when transporting.

*(Safety Rules continued on next page)*



# SAFETY RULES

## ATTENTION! BECOME ALERT! YOUR SAFETY IS INVOLVED!



*(Safety Rules continued from previous page)*

### ■ AVOID INJURY OR DEATH FROM POWER LINES:

- Stay away from power lines.
- Electrocutation can occur without direct contact.
- Check clearances before raising implement.
- Do not leave the operator's seat if any part of the tractor or implement contacts electric lines.

■ Before servicing, adjusting, repairing or unplugging, stop tractor engine, place all controls in neutral, set park brake, remove ignition key, and wait for all moving parts to stop.

■ Before working underneath a raised implement, read and follow all Operator's Manual instructions and safety rules. Implement must be attached to tractor. Lift cylinder locks must be installed and lift cylinders lowered against locks. Hydraulic system leak down, hydraulic system failures, or movement of control levers can cause equipment to drop unexpectedly and cause severe injury or death.

---

## MAINTENANCE

■ Before servicing, adjusting, repairing or unplugging, stop tractor engine, place all controls in neutral, set park brake, remove ignition key, and wait for all moving parts to stop.

■ Before working underneath a raised implement, read and follow all Operator's Manual instructions and safety rules. Implement must be attached to tractor. Lift cylinder locks must be installed and lift cylinders lowered against locks. Hydraulic system leak down, hydraulic system failures, or movement of control levers can cause equipment to drop unexpectedly and cause severe injury or death.

■ Service and maintenance work not covered in OWNER SERVICE must be done by a qualified dealership. Special skills, tools, and safety procedures may be required. Failure to follow these instructions can result in serious injury or death.

■ Do not modify or alter or permit anyone else to modify or alter the equipment or any of its components in any way.

■ Your dealer can supply original equipment hydraulic accessories and repair parts. Substitute parts may not meet original equipment specifications and may be dangerous.

■ Always wear relatively tight and belted clothing to avoid entanglement in moving parts. Wear sturdy, rough-soled work shoes and protective equipment for eyes, hair, hands, hearing and head; and respirator or filter mask where appropriate.

■ Do not allow other people in the area when operating, attaching, removing, assembling or servicing equipment.

■ Never go underneath equipment lowered to the ground or raised, unless it is properly blocked and secured. Never place any part of the body underneath equipment or between moveable parts even when the engine has been turned off. Hydraulic system leak down, hydraulic system failures, mechanical failures or movement of control levers can cause equipment to drop or rotate unexpectedly and cause severe injury or death. Follow Operator's Manual instructions for working underneath and blocking requirements, or have work done by a qualified dealer.

■ Ensure implement is properly attached, adjusted and in good operating condition.

■ Never perform service or maintenance with engine running.

■ Make sure hydraulic hoses and cylinders are fully purged of air before operating. Keep all persons away and fill the system by raising and lowering all functions several times. Air in the system can allow components to fall unexpectedly.

■ Keep all persons away from operator control area while performing adjustments, service or maintenance.

*(Safety Rules continued on next page)*



# SAFETY RULES

## ATTENTION! BECOME ALERT! YOUR SAFETY IS INVOLVED!



*(Safety Rules continued from previous page)*

- **Make certain all movement of implement components has stopped before approaching for service.**
- **Do not handle blades with bare hands. Careless or improper handling may result in serious injury.**
- **Tighten all bolts, nuts and screws to torque chart specifications. Check that all cotter pins are installed securely to ensure equipment is in a safe condition before operating.**
- **Ensure all safety decals are installed. Replace if damaged. (See Safety Decals section for location.)**

- **Ensure shields and guards are properly installed and in good condition. Replace if damaged.**
- **Do not disconnect hydraulic lines until machine is securely blocked or placed in lowest position and system pressure is released by operating all valve control levers.**

---

## STORAGE

- **Follow manual instructions for storage.**
- **Keep children and bystanders away from storage area.**

*(Safety Rules continued on next page)*

# CHECK LISTS

## PRE-DELIVERY CHECK LIST

(DEALER'S RESPONSIBILITY)

Inspect the equipment thoroughly after assembly to ensure it is set up properly before delivering it to the customer.

The following check lists are a reminder of points to inspect. Check off each item as it is found satisfactory or after proper adjustment is made.

- Check that all safety decals are installed and in good condition. Replace if damaged.
- Check that shields and guards are properly installed and in good condition. Replace if damaged.
- Check that PTO shaft is properly installed.
- Properly attach implement to tractor and make all necessary adjustments.
- Check all bolts to be sure they are tight.
- Check wheel bolts for proper torque.
- Check that all cotter pins and safety pins are properly installed. Replace if damaged.
- Check and grease all lubrication points as identified in "Service, lubrication information."
- Check the level of gearbox fluids before delivery. Service, if required, as specified in the "Service, lubrication information."
- Check that tractor hydraulic reservoir has been serviced and that hydraulic system and all functions have been operated through full cylinder stroke to purge air from system.
- After pressurizing and operating all Defoliator functions, stop tractor and make sure there are no leaks in the hydraulic system. Follow all safety rules when checking for leaks.

## DELIVERY CHECK LIST

(DEALER'S RESPONSIBILITY)

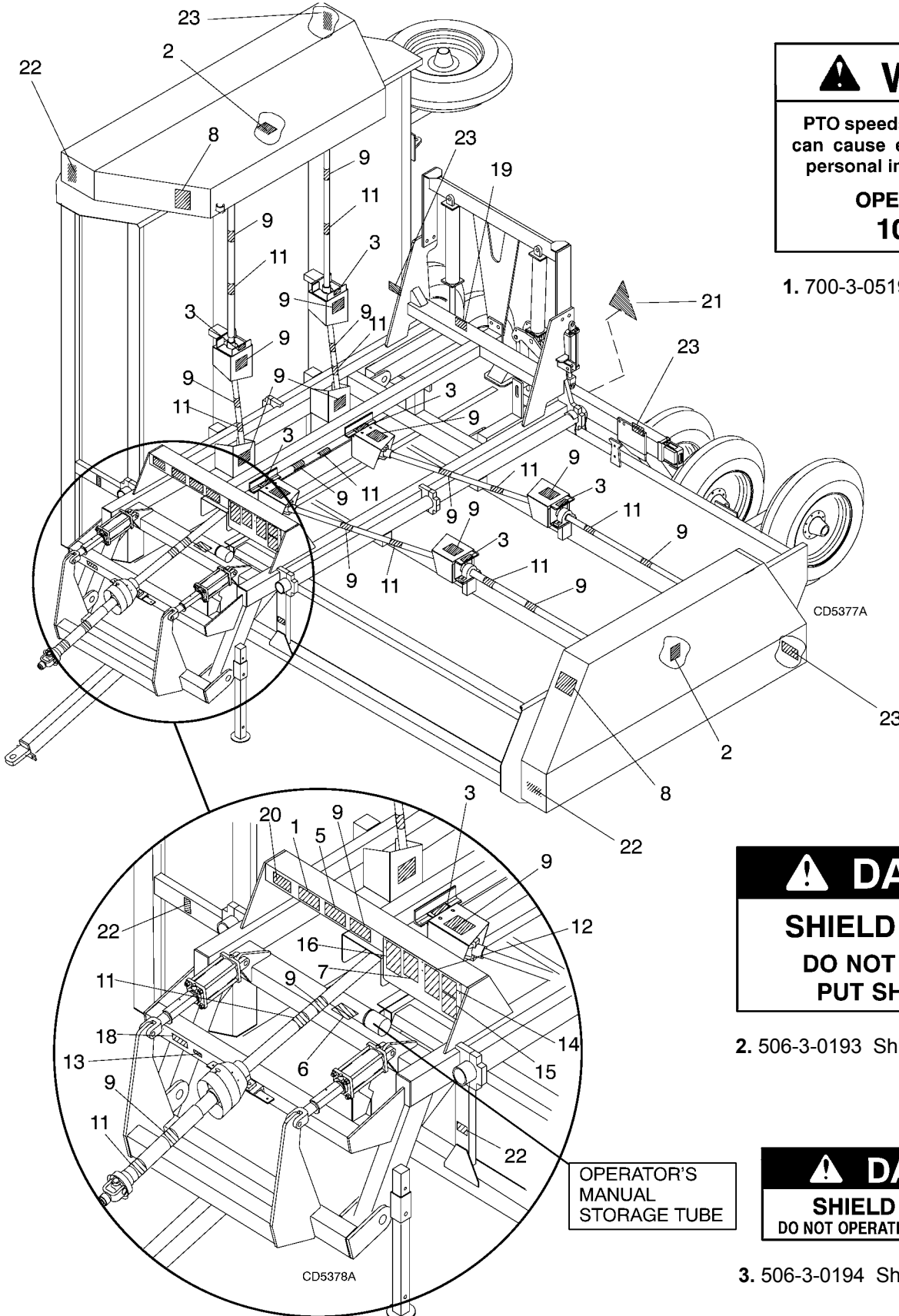
- Show customer how to make adjustments and select proper PTO speed.
- Show customer how to make adjustments.
- Instruct customer how to lubricate and explain importance of lubrication.
- Point out the safety decals. Explain their meaning and the need to keep them in place and in good condition. Emphasize the increased safety hazards when instructions are not followed.
- Present Operator's Manual and request that customer and all operators read it before operating equipment. Point out the manual safety rules, explain their meanings and emphasize the increased safety hazards that exist when safety rules are not followed.
- Show customer how to make sure driveline is properly installed and that spring-activated locking pin or collar slides freely and is seated in groove on tractor PTO shaft.
- Show customer the safe, proper procedures to be used when mounting, dismounting, and storing equipment.
- Explain to customer that when equipment is transported on a road or highway, safety devices should be used to give adequate warning to operators of other vehicles.
- Explain to customer that when equipment is transported on a road or highway, a Slow Moving Vehicle (SMV) sign should be used to provide adequate warning to operators of other vehicles.
- Explain to customer that when towing on a public road to comply with all state and local lighting/marketing laws and to use a safety tow chain.
- Make customer aware of optional equipment available so that customer can make proper choices as required.
- Point out all guards and shields. Explain their importance and the safety hazards that exist when not kept in place and in good condition.





# SAFETY & INSTRUCTIONAL DECALS

**ATTENTION! BECOME ALERT! YOUR SAFETY IS INVOLVED!**  
**Replace Immediately If Damaged!**



**WARNING**

PTO speeds higher than 1000 rpm can cause equipment failure and personal injury.

**OPERATE PTO AT  
1000 RPM**

15922-B

1. 700-3-0519 PTO Speed Warning

**DANGER**

**SHIELD MISSING**

**DO NOT OPERATE**

**PUT SHIELD ON**

18867

2. 506-3-0193 Shield Missing Warning

**DANGER**

**SHIELD MISSING**

**DO NOT OPERATE - PUT SHIELD ON**

18869-B

3. 506-3-0194 Shield Missing Warning

OPERATOR'S  
MANUAL  
STORAGE TUBE

(Safety Decals continued on next page)






# SAFETY & INSTRUCTIONAL DECALS

## ATTENTION! BECOME ALERT! YOUR SAFETY IS INVOLVED!

### Replace Immediately If Damaged!



 <p style="font-size: small;">19924-B</p>	<p><b>⚠ WARNING</b></p> <p><b>HIGH-PRESSURE HYDRAULIC OIL LEAKS CAN PENETRATE SKIN RESULTING IN SERIOUS INJURY, GANGRENE OR DEATH.</b></p> <ul style="list-style-type: none"> <li>■ Check for leaks with cardboard; never use hand.</li> <li>■ Before loosening fittings: lower load, release pressure, and be sure oil is cool.</li> <li>■ Consult physician immediately if skin penetration occurs.</li> </ul>
--	--

5. 506-3-0195 Hydraulic Pressure Warning

<p><b>⚠ DANGER</b></p>

<p><b>GUARD MISSING. DO NOT OPERATE.</b></p>
<p><b>⚠ DANGER</b></p>

<p><b>GUARD MISSING. DO NOT OPERATE.</b></p> <p style="font-size: x-small;">33347E</p>
<p><b>⚠ DANGER</b></p>

11. 903-17456 Driveline Safety Sign

<p><b>⚠ WARNING</b></p>
<p><b>MANUAL CONTAINER AND MANUAL ARE MISSING</b></p> <ul style="list-style-type: none"> <li>■ REPLACE AND READ BEFORE OPERATING.</li> <li>■ KEEP MANUAL CONTAINER AND MANUAL MOUNTED IN THIS LOCATION. (Available from dealer or call 1-800-319-6637.)</li> </ul> <p><b>FAILURE TO FOLLOW MANUAL INSTRUCTIONS AND SAFETY RULES CAN RESULT IN SERIOUS INJURY OR DEATH.</b> <span style="float: right; font-size: x-small;">506-3-0192</span></p>

6. 506-3-0192 Manual Container Warning

<p><b>⚠ DANGER</b></p>

<p style="text-align: center;"><b>ROTATING DRIVELINE CONTACT CAN CAUSE DEATH KEEP AWAY!</b></p> <p><b>DO NOT OPERATE WITHOUT-</b></p> <ul style="list-style-type: none"> <li>■ All driveline guards, tractor and equipment shields in place</li> <li>■ Drivelines securely attached at both ends</li> <li>■ Driveline guards that turn freely on driveline</li> </ul> <p style="text-align: right; font-size: x-small;">18864-C</p>

9. 506-3-0196 Rotating Driveline Warning

<p><b>⚠ WARNING</b></p>
<p><b>TO AVOID SERIOUS INJURY OR DEATH:</b></p> <ul style="list-style-type: none"> <li>■ Read Operator's Manual before operating, servicing or repairing equipment. Follow all safety rules and instructions. (Manuals are available from dealer or, in the United States and Canada, call 1-800-319-6637.)</li> <li>■ Keep all guards in place, properly secured and in good condition. Replace if damaged.</li> <li>■ Operate from tractor seat only.</li> <li>■ Do not allow any other persons in the area when operating.</li> <li>■ Before dismantling tractor:             <ul style="list-style-type: none"> <li>■ Disengage PTO.</li> <li>■ Lower equipment and all raised components.</li> <li>■ Stop engine, remove key and engage brake.</li> <li>■ Operate hydraulic valve levers to release any pressure.</li> <li>■ Allow no children or untrained persons to operate the equipment.</li> </ul> </li> </ul> <p><b>FAILURE TO FOLLOW THESE INSTRUCTIONS CAN RESULT IN SERIOUS INJURY OR DEATH.</b> <span style="float: right; font-size: x-small;">PN 700-3-0493</span></p>

7. 700-3-0493 Read Manual Warning



13. 200-3-1366 Serial Number Tag

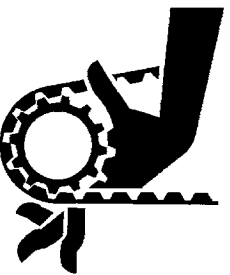


# SAFETY & INSTRUCTIONAL DECALS

## ATTENTION! BECOME ALERT! YOUR SAFETY IS INVOLVED!

### Replace Immediately If Damaged!

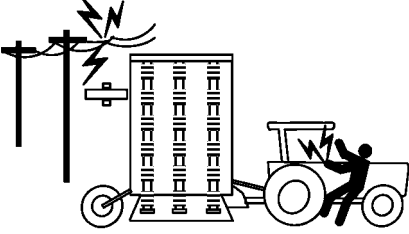


<b>⚠ WARNING</b>	
	<p style="text-align: center;"><b>ROTATING DRIVE HAZARDS</b></p> <ul style="list-style-type: none"> <li>■ Before opening drive guard:           <ul style="list-style-type: none"> <li>■ Disengage PTO drive,</li> <li>■ Lower equipment to ground,</li> <li>■ Stop engine, remove key and engage brake,</li> <li>■ Operate valve levers to release any hydraulic pressure,</li> <li>■ Wait for all rotation to stop,</li> <li>■ Disconnect driveline from tractor PTO.</li> </ul> </li> <li>■ Before starting tractor:           <ul style="list-style-type: none"> <li>■ Close drive cover and secure,</li> <li>■ Keep guard in good condition.</li> </ul> </li> </ul> <p><b>FAILURE TO FOLLOW THESE INSTRUCTIONS CAN RESULT IN SERIOUS INJURY OR DEATH.</b></p> <p style="font-size: small; text-align: left;">PN 700-3-0495</p>

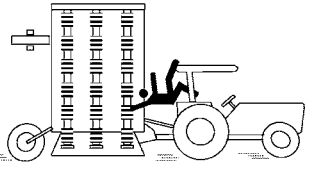
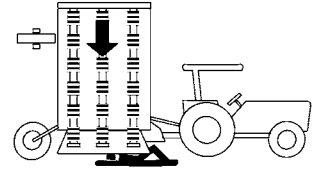
8. 700-3-0495 Rotating Drive Hazard



21. 500-3-1696 SMV Sign

<b>⚠ DANGER</b>	
	
<b>ELECTROCUTION HAZARD</b>	
<ul style="list-style-type: none"> <li>● Keep away from electric lines.</li> <li>● Electrocution can result without direct contact.</li> </ul> <p style="text-align: center;"><b>Power lines can cause serious injury or death.</b></p> <p style="font-size: small; text-align: right;">50031687</p>	

14. 500-3-1687 Electrocution Hazard

<b>⚠ WARNING</b>	
	
<b>FALLING OFF CAN RESULT IN BEING RUN OVER.</b>	
<ul style="list-style-type: none"> <li>■ Buckle Up! Tractor should have ROPS and seat belt.</li> <li>■ Allow no riders on tractor or equipment.</li> </ul>	
<b>RAISED EQUIPMENT OR COMPONENTS CAN DROP AND CRUSH.</b>	
<ul style="list-style-type: none"> <li>■ Before servicing, working on or working underneath equipment, read manual instructions.</li> <li>■ Manual instructions and all safety rules for securing equipment and components must be followed to prevent crushing from hydraulic leak down, hydraulic system failure, movement of control levers or mechanical component failures.</li> </ul>	
<b>FALLING OFF OR GOING UNDER RAISED EQUIPMENT CAN RESULT IN SERIOUS INJURY OR DEATH.</b>	
50031688	

12. 500-3-1688 Raised Equipment Warning

<b>⚠ CAUTION</b>	
<b>AVOID ROTOR DAMAGE FROM RAISING OR LOWERING WINGS.</b>	
<p>Before raising or lowering wings:</p> <ul style="list-style-type: none"> <li>● Follow all manual instructions and safety rules.</li> <li>● Raise equipment to maximum height to provide necessary ground clearance below rotor.</li> <li>● Install cylinder locks on all four lift cylinders.</li> </ul> <p><b>FAILURE TO FOLLOW INSTRUCTIONS CAN RESULT IN ROTOR DAMAGE AND PERSONAL INJURY.</b></p> <p style="font-size: x-small; text-align: right;">50031689-A</p>	

20. 500-3-1689 Rotor Damage Warning

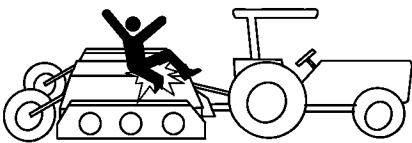


# SAFETY & INSTRUCTIONAL DECALS

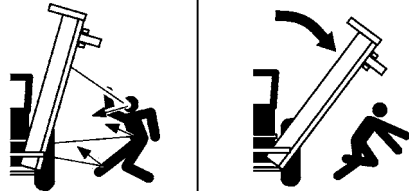
## ATTENTION! BECOME ALERT! YOUR SAFETY IS INVOLVED!

### Replace Immediately If Damaged!

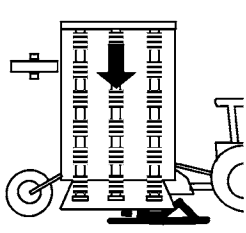
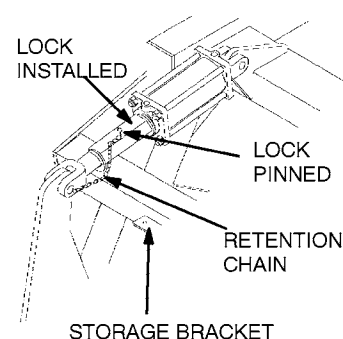


<b>⚠ WARNING</b>

<p><b>STANDING ON DEFOLIATOR CAN RESULT IN FALLING INTO FLAIL ROTORS.</b></p> <ul style="list-style-type: none"> <li>■ Do not stand or walk on defoliator housing.</li> <li>■ Defoliator covering will not support people or animals.</li> </ul> <p><b>FALLING INTO FLAIL ROTORS CAN RESULT IN SERIOUS INJURY OR DEATH.</b></p> <p style="text-align: right; font-size: small;">PN-50031690</p>

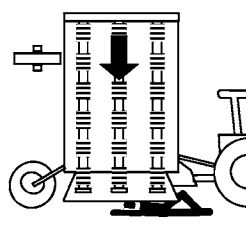
15. 500-3-1690 Stand/Walk on Defoliator Warning

<b>⚠ WARNING</b>

<p><b>RAISED WING EXPOSES FLAIL ROTORS AND INCREASES THROWN OBJECT HAZARDS.</b></p> <ul style="list-style-type: none"> <li>■ Only raise wings for transport.</li> <li>■ Read and follow all manual instructions. Stop equipment and pin wings in "Lock-Up" position before transporting.</li> <li>■ Wings must be completely lowered to the ground when operating.</li> </ul> <p><b>RAISED WING CAN FALL AND CRUSH.</b></p> <ul style="list-style-type: none"> <li>■ Keep away. Never go under a raised wing.</li> <li>■ Raised wing must always be pinned in "Lock-Up" position.</li> <li>■ Lower wings after transport.</li> <li>■ Wings must be lowered before any service work and for storage.</li> </ul> <p><b>FAILURE TO FOLLOW INSTRUCTIONS CAN RESULT IN SERIOUS INJURY OR DEATH.</b></p> <p style="text-align: right; font-size: x-small;">50031691</p>

16. 500-3-1691 Raised Wing Hazard

<b>⚠ WARNING</b>		
	<p><b>RAISED EQUIPMENT CAN DROP AND CRUSH</b></p> <p><b>Before working on or underneath equipment:</b></p> <ul style="list-style-type: none"> <li>■ Read and follow all manual instructions and safety rules.</li> <li>■ Install cylinder locks on both front lift cylinders.</li> <li>■ Cylinder locks must be installed correctly, kept in good condition, and stored on equipment when not in use.</li> <li>■ All four corners of both wings must be securely blocked with jack stands.</li> </ul> <p><b>FAILURE TO FOLLOW INSTRUCTIONS CAN RESULT IN SERIOUS INJURY OR DEATH.</b></p>	

18. 500-3-1693 Front Transport Lock Warning

<b>⚠ WARNING</b>		
	<p><b>RAISED EQUIPMENT CAN DROP AND CRUSH</b></p> <p><b>Before working on or underneath equipment:</b></p> <ul style="list-style-type: none"> <li>■ Read and follow all manual instructions and safety rules.</li> <li>■ Install cylinder locks on both rear lift cylinders.</li> <li>■ Cylinder locks must be installed correctly, kept in good condition, and stored on equipment when not in use.</li> <li>■ All four corners of both wings must be securely blocked with jack stands.</li> </ul> <p><b>FAILURE TO FOLLOW INSTRUCTIONS CAN RESULT IN SERIOUS INJURY OR DEATH.</b></p>	

19. 500-3-1694 Rear Transport Lock Warning



# OPERATION

Safety is a primary concern in the design and manufacture of our products. Unfortunately, our efforts to provide safe equipment can be wiped out by an operator's single careless act.

In addition to the design and configuration of equipment, hazard control and accident prevention are dependent upon the awareness, concern, judgment, and proper training of personnel involved in the operation, transport, maintenance and storage of equipment.

It has been said "The best safety device is an informed, careful operator." We ask you to be that kind of operator.



## WARNING

- Operators must be instructed in and be capable of the safe operation of the equipment, its attachments and all controls. Do not allow anyone to operate this equipment without proper instructions.
- Never allow children or untrained persons to operate equipment.



## CAUTION

- If you do not understand any part of this manual and need assistance, see your dealer.
- Always wear relatively tight and belted clothing to avoid entanglement in moving parts. Wear sturdy, rough-soled work shoes and protective equipment for eyes, hair, hands, hearing and head.



## WARNING

- Make sure spring-activated locking pin or collar slides freely and is seated firmly in tractor PTO spline groove.
- Before starting tractor, check all equipment driveline guards for damage and make sure they rotate freely on all drivelines. Replace any damaged guards. If guards do not rotate freely on drive-lines, repair and replace bearings before operating.

- A minimum 20% of tractor and equipment weight must be on tractor front wheels with attachments in transport position. Without this weight, tractor could tip over causing personal injury or death. The weight may be attained with a loader, front wheel weights, ballast in tires or front tractor weights. Weigh the tractor and equipment. Do not estimate.



## WARNING

- Make sure all safety decals are installed. Replace if damaged. (See Safety Decals section for location.)
- Make sure shields and guards are properly installed and in good condition. Replace if damaged.
- Do not allow bystanders in the area when operating, attaching, removing, assembling, or servicing equipment.
- Never walk, stand or place yourself or others under a raised wing or in the path of a lowering wing. Hydraulic system leak down, hydraulic system failures, mechanical failures or movement of control levers can cause wings to drop unexpectedly and cause severe injury or death.
- Keep bystanders away from equipment.
- Never go underneath equipment lowered to the ground or raised, unless it is properly blocked and secured. Never place any part of the body underneath equipment or between moveable parts even when the engine has been turned off. Hydraulic system leak down, hydraulic system failures, mechanical failures or movement of control levers can cause equipment to drop or rotate unexpectedly and cause severe injury or death. Follow Operator's Manual instructions for working underneath and blocking requirements, or have work done by a qualified dealer.
- Keep hands, feet, hair and clothing away from equipment while engine is running. Stay clear of all moving parts.
- Never allow riders on power unit or attachment.

## Operation Continued

■ Power unit must be equipped with ROPS or ROPS CAB and seat belt. Keep seat belt securely fastened. Falling off power unit can result in death from being run over or crushed. Keep foldable ROPS systems in “locked up” position at all times.

■ Operate only in daylight or good artificial light.

■ Always comply with all state and local lighting and marking requirements.

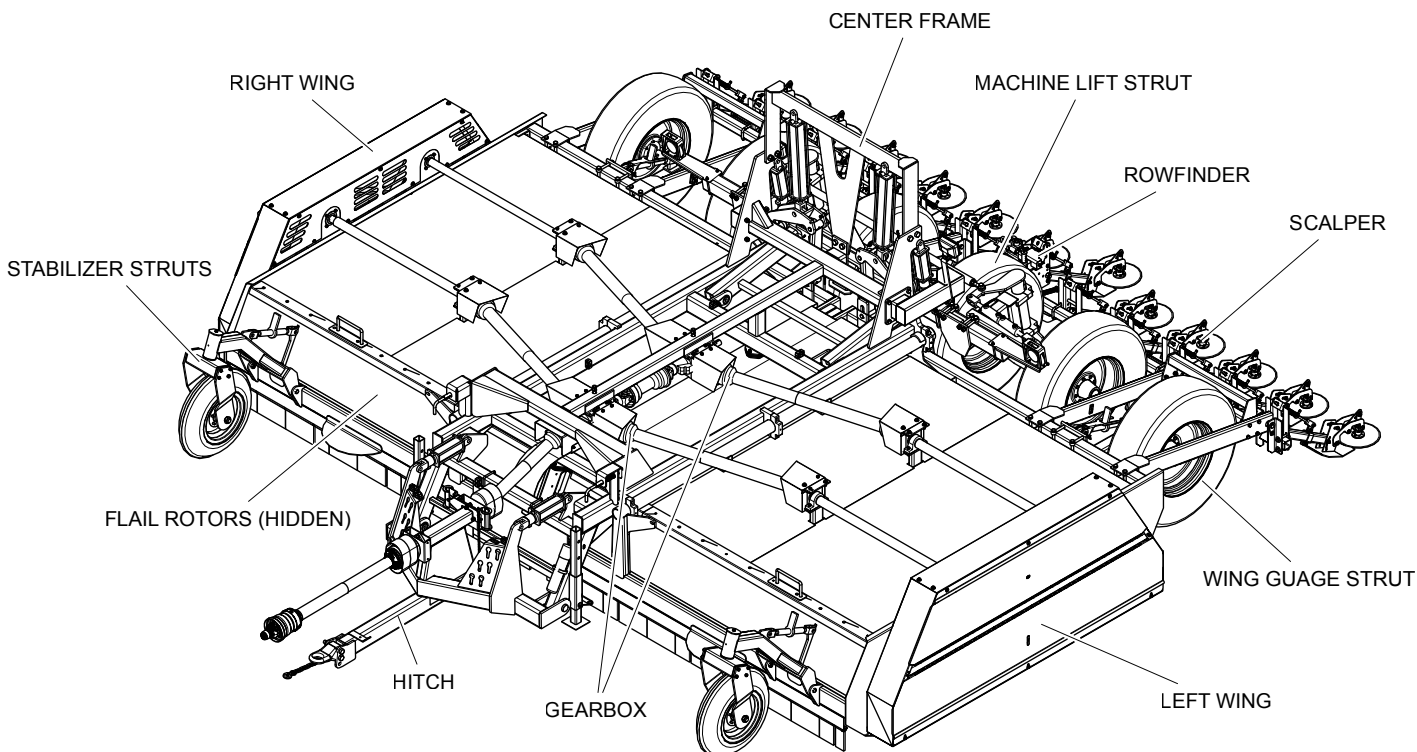


**CAUTION**



**DANGER**

■ Avoid contact with electrical wires.



**Figure 1.** Principal Components

### PRINCIPAL COMPONENTS

The Alloway Folding Defoliator is built as three major components.

- a) Right Wing Assembly
- b) Left Wing Assembly
- c) Center Frame

The center frame is supported by hydraulically adjustable wheel struts and the hydraulically adjustable hitch. The main driveline and two gearboxes are mounted to the center frame.

Each wing assembly holds three flail rotor assemblies, their drive components, and a manually adjustable wing gauge wheel.

Optional scalper attachments can be mounted directly to each wing assembly.

Optional rear wheel steering struts are available.

## Operation *Continued*

### PRE-OPERATION CHECK LIST

(OWNER'S RESPONSIBILITY)

#### IMPORTANT

■ **This Pre-Operation Check List is provided for the operator. It is important to follow for both personal safety and maintenance of the Folding Defoliator.**

To assure safe and efficient operation, it is essential that each machine operator read and understand the operating procedures and related safety requirements outlined in this manual.

Complete the Pre-Operation Check List after the first hour of field operation and before each shift thereafter.

- Show customer how to make adjustments.
- Keep Operator's Manual in storage tube for ready reference and use.
- Review and follow all safety rules and safety decal instructions on pages 5 through 12.
- Check that all safety decals are installed and in good condition. Replace if damaged.
- Check that all shields and guards are properly installed and in good condition. Replace if damaged.
- Check that all hardware and cotter pins are properly installed and secured.
- Check the condition of all flails and check that they swing freely. Replace any damaged or broken flails.
- Check the condition of the scalpers. Adjust or repair as required.
- Check tire pressures. Service as necessary.
- Check that equipment is properly and securely attached to tractor.
- Make sure driveline spring-activated locking collar slides freely and is seated firmly in tractor PTO spline groove.
- Before starting tractor, check all equipment driveline guards for damage and make sure they rotate freely on all drivelines. Replace any damaged guards. If guards do not rotate freely on drivelines, repair and replace bearings before operating.
- Do not allow riders.
- Check and keep all bystanders away from equipment working area.
- Check the condition of all drive belts. Tension or align as required. Replace any that are frayed or broken.
- Check all lubrication points and grease as instructed in "Service, lubrication information" Make sure the PTO slip joint is lubricated and that the gearbox fluid levels are correct.
- Set tractor PTO at correct rpm for your equipment.
- Check that all hydraulic hoses and fittings are in good condition and not leaking before starting tractor. Check that hoses are not twisted, bent sharply, kinked, frayed or pulled tight. Replace any damaged hoses immediately.
- Raise and lower equipment to make sure air is purged from hydraulic cylinders and hoses.
- Make sure tractor 3-point lift links do not interfere with hydraulic hoses or driveline throughout full turning range.
- Make sure tractor ROPS or ROPS CAB and seat belt are in good condition. Keep seat belt securely fastened during operation to prevent falling off.
- Before starting engine, operator must be in tractor seat with seat belt fastened. Place transmission in neutral or park, engage brake and disengage tractor PTO.
- Check that rubber flaps are in good condition, pivot freely, and hang without gaps.

## Operation Continued

### BREAK-IN OF THE FOLDING DEFOLIATOR

The following should be observed when operating the unit for the first time:

1. Attach PTO shaft. Remove grease zerks to gain access to the set screws for tightening on unit.

#### After operating for 1/2 hour or after completing five acres

2. Check all nuts, bolts, and other fasteners. Tighten to specifications given in the Bolt Torque Chart, page 66.
3. Check and re-torque on flail mounting bracket fasteners
4. Tighten wheel bolts to specifications given in the Bolt Torque Chart, page 66.
5. Check that the flails are in good condition and swing freely.
6. Check oil level in the gearbox. Add oil as required.
7. Check that the PTO driveline shield turns freely.
8. Lubricate all grease points.

#### After operating for 5 hours

9. Repeat Steps 1 through 6 above.
10. Check the tension of the drive belts. Refer to the Service and Maintenance section for the procedure. Adjust as required.

#### After operating for 10 hours

11. Repeat steps 1 through 6.
12. Check tension of drive belts. Adjust as required.

#### After operating for 15, and 20 hours

13. Check tension of drive belts. Adjust as required.

### EQUIPMENT MATCHING

Use only a tractor with adequate power and weight to operate this Defoliator. The following specifications are guidelines for a proper match.

#### PTO

Tractor must be equipped with a 1000 RPM PTO, never operate at 540 rpm. The Defoliator driveline can be ordered with a tractor yoke that matches a 1-3/8" 21-spline shaft or a 1-3/4" 20-spline shaft. Carefully measure PTO driveline in operating positions to ensure that there is proper engagement between male and female shaft to prevent the driveline from coming apart or bottoming out. Standard PTO driveline must not be shorter than 40.13" or longer than 56.63" in any position during operation, as shown in Figure 2.



#### WARNING

- Connect PTO driveline directly to tractor PTO shaft. Never use adapter sleeves or adapter shafts. Adapters can cause driveline failures due to incorrect spline or incorrect operating length and result in personal injury or death. The use of adapters will void warranty due to damaged caused to the tractor PTO, PTO driveshaft or implement.

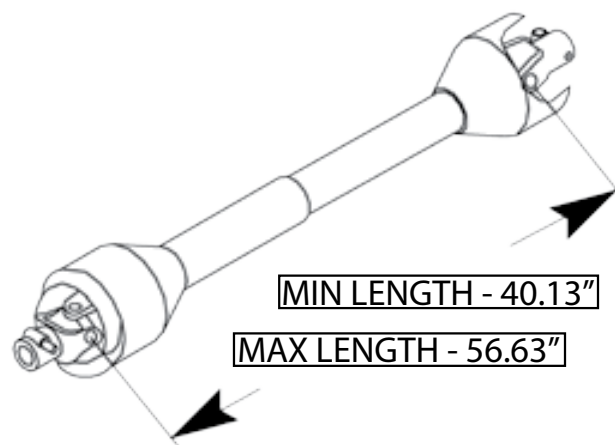


Figure 2a. PTO Driveline Operating Length



# Operation Continued

## CV DRIVELINE TURNING LIMITS

You must not exceed a turning angle of 80 degrees at the head of the Constant Velocity driveline or damage will occur.

### IMPORTANT

■ The CV PTO shaft allows the operator to make relatively short turns at the end of the field, without disengaging the PTO drive. However do not make turns tighter than 80 degrees off the straight position. If turning radius exceeds 80 degrees, disengage tractor PTO before starting the turn.

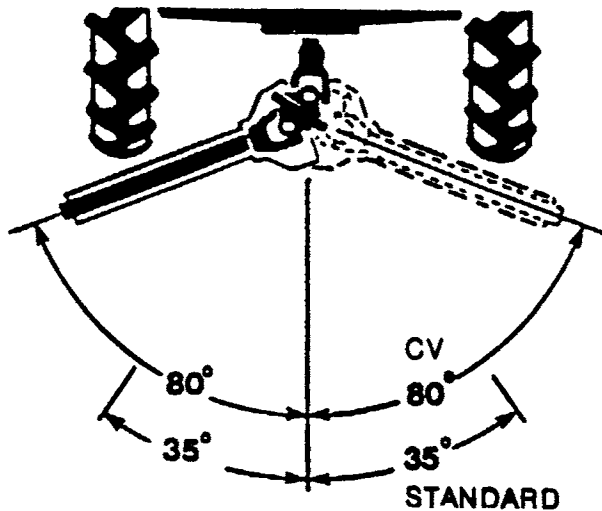


Figure 2b. Driveline Angles

## HYDRAULIC SYSTEM

The tractor hydraulic system must be capable of supplying 8 gpm (22 lpm) at 2000 psi (13,900 kPa). The tractor must be equipped with a minimum of three operator controlled hydraulic remote valves (one additional valve is required if optional rear steering is used).

Use #1 tractor remote valve to supply hydraulic power for the rear lift cylinders.

Use #2 tractor remote to supply hydraulic power for the front lift cylinders.

Use #3 remote valve to supply hydraulic power for the wing lift cylinders.

Use #4 remote valve to supply hydraulic power for the optional rear steering cylinder.

## DRAWBAR WITH CLEVIS

The tractor drawbar must be set to provide 16 - 20" (406 mm - 508 mm) between the end of the PTO shaft and the center of the drawbar pin. A tractor manufacturer's clevis hitch (hammer strap and hitch pin) must be installed.

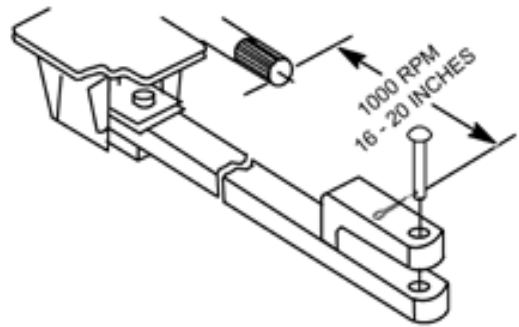


Figure 3. Drawbar Dimensions

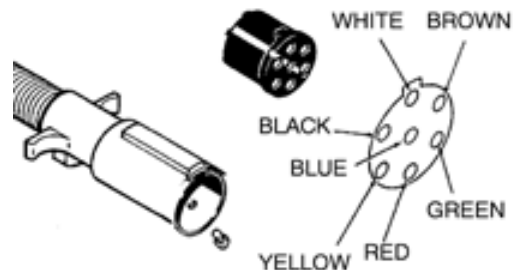
## ELECTRICAL SYSTEM (Figure 5)

The tractor must be equipped with a SAE J560a 7-pin electrical connector. When connected to the Defoliator, turn signals and warning flashers will operate with the tractor lighting system.

The Defoliator is equipped with warning flashers and turn signals located on each rear corner of the center frame. Warning lights must be functional whenever the Defoliator is transported on public highways.

See your tractor operator manual for instructions on warning light and turn signal operation.

If warning lights and turn signals do not function correctly, see your Alloway dealer.



- White - Ground
- Black - Field Lights (not used)
- Blue - Auxiliary Power (not used)
- Red - Auxiliary Power (not used)
- Yellow - Left Turn Signal
- Green - Right Turn Signal
- Brown - Tail Light

Figure 5. 7-Pin Electrical Connector

## Operation Continued

### TRACTOR BALLAST

The tractor should be equipped with manufacturer's maximum allowable front end ballast for operational and transport stability.

### PROPERLY MOUNT AND DISMOUNT TRACTOR

Proper safety procedures should be followed when mounting tractor. The operator should be in the tractor seat with the seat belt securely fastened and any foldable ROPS system should be in the "locked-up" position before starting the engine or operating any controls.

Whenever the operator is required to leave the tractor seat, follow proper safety procedures. The "proper dismounting procedure" is to stop the engine, set brakes, remove the ignition key, and wait for all moving parts to stop before removing seat belt to dismount. After dismounting the tractor, secure wheels with chocks.

### ATTACHING DEFOLIATOR TO TRACTOR

**Note:** The following procedure presumes that the Defoliator is in "STORED POSITION" as described on page 23, with rear wheel/lift cylinder locks installed.

Make sure there are no bystanders between tractor and Defoliator or in the area.

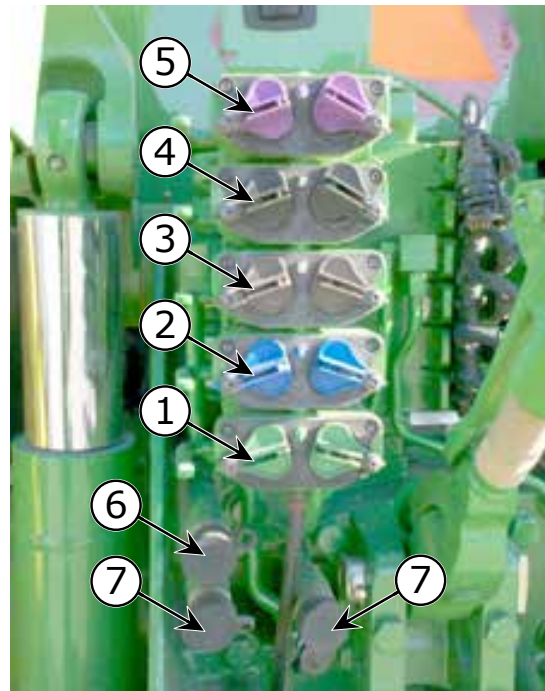
Carefully back up until the tractor drawbar aligns with the Defoliator hitch.

Stop engine, set parking brake, wait for all moving parts to stop, and remove ignition key before dismounting.

Clean the hydraulic couplers and fittings to avoid oil contamination.

Connect the hydraulic hoses which control the front hitch/lift cylinders to remote valve #2 hydraulic couplers on the tractor. Connect these hoses so that moving the operator control lever forward lowers the Defoliator (raises the hitch tongue) and moving the operator control lever rearward raises the Defoliator (lowers the hitch tongue).

From the tractor seat, hydraulically position the height of Defoliator hitch and back up the tractor to allow the tractor clevis to align with the Defoliator hitch.



1. Hydraulic valve #1 (Rear Wheel/lift cylinders)
2. Hydraulic valve #2 (Front hitch/lift cylinders)
3. Hydraulic valve #3 (Wing lift cylinders)
4. Hydraulic valve #4 (Rear Steer Override)
5. Hydraulic valve #5 (Rear Steer Self-Centering System  
*if Power Beyond is not available*)
6. Power Beyond Pressure (Rear Steer Self-Centering System)
7. Power Beyond Return (Rear Steer Self-Centering System)

**Figure 6.** Tractor Connection (Typical)

Stop engine, set parking brake, wait for all moving parts to stop, place all controls in neutral, and remove key before dismounting the tractor.

Install tractor manufacturer's clevis hitch pin and secure with tractor manufacturer's lock mechanism.

Attach the safety chain to the drawbar support of the tractor.

Insert the 7-pin male Defoliator electrical cable into the tractor female connector. Route electrical wires to prevent chafing, abrasion, or contact with rotating components.

Connect hydraulic hoses to tractor hydraulic couplers as shown in Figure 6.

Hydraulically raise the Defoliator, stop engine, set park brake, and wait for all moving parts to stop, and remove ignition key before dismounting.

Install cylinder locks on front hitch/lift cylinders.

# Operation Continued



**Figure 7.** Front Hitch/Lift Cylinder Locks (Installed)

Raise parking stands and secure in raised position, Figure 8. Make sure all cylinder locks are in place.

Check that all PTO driveline guards are in place and that driveshaft telescopes correctly. Attach PTO driveshaft to tractor and make sure locking pin or collar is fully engaged.

Verify that all tractor hydraulic control lever movements are correct before operating or transporting the Defoliator.



**Figure 8.** Parking Stand in Raised Position

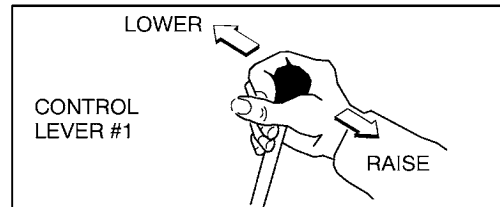
## VERIFICATION OF CONTROL MOVEMENTS

Comply with all Safety Rules and start the tractor. Check that all tractor hydraulic control lever movements operate the Defoliator correctly as shown in Figure 10.

Defoliator movements must be correct before proceeding with field operation. If movements are not correct, recheck all hydraulic coupler connections.

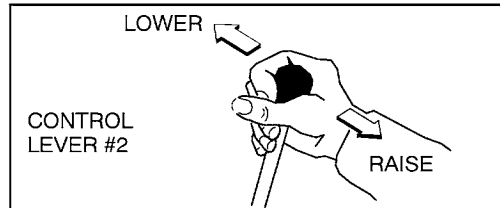


**Figure 9.** Hose Labeling Diagram



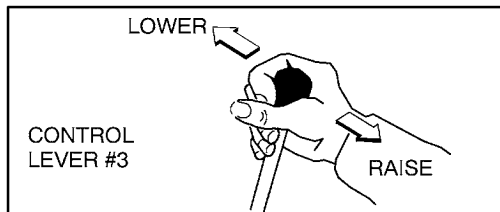
- Handle forward - Lower Rear of Defoliator
- Handle back - Raise Rear of Defoliator

**Figure 10a.** Rear Wheel/Lift Cylinders



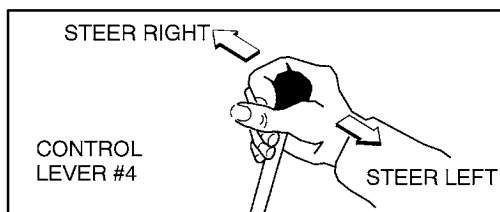
- Handle forward - Lower Front of Defoliator
- Handle back - Raise Front of Defoliator

**Figure 10b.** Front Hitch/Lift Cylinders



- Handle forward - Lower Wings to Operating Position
- Handle back - Raise Wings to Transport Position

**Figure 10c.** Wing Raise/Lower Cylinders



- Handle forward - Defoliator Steers to Right
- Handle back - Defoliator Steers to Left

**Figure 10d.** Rear Steering Cylinders (Optional)



## Operation Continued

### DISCONNECTING DEFOLIATOR FROM TRACTOR

After following the instructions for “Disconnecting Defoliator from Tractor” the Defoliator will be in “STORED POSITION.” In “STORED POSITION,” Defoliator wings must be lowered to rest on wing gauge wheels, rear wheel/lift cylinder locks installed, both parking stands lowered, front hitch in lowered position, PTO driveline in storage bracket, and unit parked on a hard level surface.

Always be aware of hydraulic system leak-down. Never place any part of your body underneath equipment or between moveable parts.

Check that park stands, park stand brackets, park lockpins, and lockpin retaining chains are in good condition. Replace any missing or damaged park stand component immediately.

Park Defoliator on a hard level surface.

If Defoliator wings are in the raised transport position, carefully lower wings as instructed in “**LOWERING WINGS to OPERATING POSITION**”

Stop the engine, set brakes, remove ignition key, and wait for all moving parts to stop before dismounting.

Set and secure parking stands in lowered position (Figure 13).



**Figure 13.** Parking Stand in Lowered Position (Right Side Shown)

Insure that rear cylinder locks are installed as shown in Figure 14.



**Figure 14.** Rear Wheel/Lift Cylinder Lock

Front cylinder locks should be in storage position as shown in Figure 15.



**Figure 15.** Front Hitch/Lift Cylinder Lock Storage

Lower Defoliator to rest on rear cylinder locks and parking stands. Raise hitch slightly from tractor drawbar so that drawbar pin can be removed.

Stop engine, set parking brake, remove ignition key, and wait for all moving parts to stop before dismounting.

## Operation Continued

Remove drawbar pin.

Disconnect PTO from tractor shaft and place PTO on PTO storage rest, Figure 16. Carefully drive tractor ahead far enough to disengage hitch from tractor drawbar.

Disconnect hydraulic lines and electrical connector.



Figure 16. PTO Rest

### RAISING WINGS TO TRANSPORT POSITION



#### WARNING

■ Never walk, stand or place yourself or others under a raised wing or in the path of a lowering wing. Hydraulic system leak down, hydraulic system failures, mechanical failures or movement of control levers can cause wings to drop unexpectedly and cause severe injury or death.



#### CAUTION

■ Before raising or lowering wings, front hitch/lift and rear wheel/lift cylinders must be fully extended and all four cylinder locks installed. This prevents rotor and bearing support damage that can result from ground contact.

When raising wings to transport position, the Defoliator must be securely attached to the tractor with front hitch/lift and rear wheel/lift cylinder locks installed as shown in Figure 7 and Figure 14.

Make sure that wing lock-up pins are in their storage positions as shown in Figure 14.

Fully raise front and rear of Defoliator and move tractor control lever #3 to raise wings to transport position.

Stop engine, set parking brake, wait for all moving parts to stop, and remove ignition key before dismantling.

Install wing lock-up pins as shown in Figure 17.

Check that the hitch is securely attached to the tractor drawbar and the safety chain is properly fastened.

Lower hydraulic cylinders to rest on cylinder locks.



Figure 17a. Wing Lock Pin Installed



Figure 17b. Wing Lock Pin Storage

## Operation Continued

### LOWERING WINGS TO OPERATING POSITION



#### WARNING

■ Never walk, stand or place yourself or others under a raised wing or in the path of a lowering wing. Hydraulic system leak down, hydraulic system failures, mechanical failures or movement of control levers can cause wings to drop unexpectedly and cause severe injury or death.



#### CAUTION

■ Before raising or lowering wings, front hitch/lift and rear wheel/lift cylinders must be fully extended and all four cylinder locks installed. This prevents rotor and bearing support damage that can result from ground contact.

When lowering wings to operating position, the Defoliator must be properly attached to the tractor on level ground, with front hitch/lift and rear wheel/lift cylinder locks installed and pinned as shown in Figure 7 and Figure 14.

Use tractor hydraulic lever #3 to relieve pressure on wing lock pins.

Stop engine, set parking brake, wait for all moving parts to stop, and remove ignition key before dismounting.

Remove wing lock-up pins and place in storage position as shown in Figure 17.

Lower the wings to rest the wing gauge wheels on the ground. Retract wing cylinders completely to allow wings to follow ground contour during operation.

**Note:** Pull ahead several feet to help align wing wheels before making final field adjustments.



Figure 20. Rear Wheel/Lift Cylinder Lock Storage



## Operation Continued

### FIELD OPERATION

The Alloway Defoliator will give best performance if it is properly set to work in existing conditions.

#### IMPORTANT

■ **Field conditions may require additional fine adjustment since tractor tracks are usually lower from cultivating and other previous field operations.**

Machine setting may require adjustment within or between fields as conditions change. Changes in soil moisture, soil density or even beet varieties may affect performance.

Defoliator must be adjusted so that wheels are centered between rows and rubber flail assemblies are centered over beet rows. All flail tips should be about 1/2" above the ground.

Before entering the field initially, the machine should be unfolded on firm and level ground.

#### LEVELING THE DEFOLIATOR

Place Defoliator wings in operating position.

Remove front hitch/lift and rear wheel/lift cylinder locks.

Lower rear of machine until the rubber flail tips contact the beets 1/2" below the crown.

Lower the front of the machine until the Defoliator wings are parallel to the ground. Adjust front hitch/lift and rear wheel/lift cylinder stop collars (Figure 21) to establish the operating position of the center frame. Fine adjustment may be required to match field conditions.

Adjust wing gauge wheels so that wings are level across the beet tops.

Adjust the ratchet jacks on each gauge wheel strut to level the wings and establish flail cutting height.

On machines equipped with steel flail front rotor, the steel flail tips are 4" shorter than the rubber flail tips. Steel flails should remove only greens and not damage beet crowns, while rubber flails remove the residual foliage and deposit leaves between the beet rows.

Machines may be equipped with rubber flails on all rotors. The load of leaf removal should be split between the #1 and #2 rotor. For that reason fewer flails are used on the #1 rotor.



Figure 21. Rear Wheel/Lift Cylinder Stop Collars

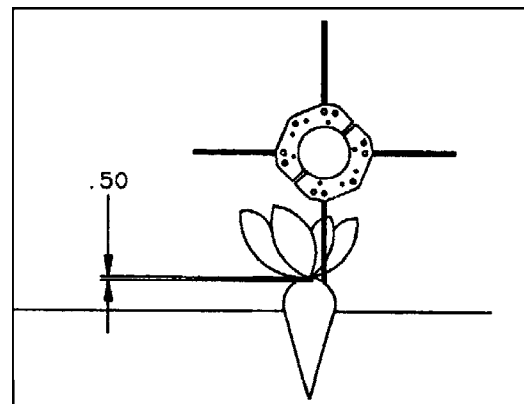


Figure 22. Leveling Defoliator



Figure 23. Gauge Wheel Ratchet Jack

# Operation *Continued*

## ENTERING THE FIELD

Pull into the field with the tractor centered on the first set of rows.

Lower the machine front and rear to the pre-set position. Scalpers will automatically lower after the rear depth control cylinders bottom out.

## STARTING DEFOLIATOR

With the tractor engine at idle, slowly engage the PTO and choose your forward speed setting. Recommended speed in average conditions is 2 to 3 mph.

Increase engine speed to PTO speed.

Release clutch and move tractor forward following the beet rows.

If the performance of the Defoliator is not satisfactory, stop the unit and make any necessary adjustments.

## STOPPING DEFOLIATOR

Reduce engine speed and depress clutch. Take tractor out of gear. After engine has slowed to idle, disengage PTO.

## IMPORTANT

- **Never disengage PTO at high RPM because the inertia of the turning rotors in the Defoliator can damage the tractor PTO brake.**

Stop engine, set parking brake, wait for all moving parts to stop, and remove ignition key before dismounting.

Check behind the Defoliator to observe performance.

Further fine-adjustment on wing gauge wheels and/or center carrier may be needed for satisfactory performance.

## FIELD PERFORMANCE

Many factors will influence the performance of the Defoliator:

- Bulk of leaf canopy
- Moisture content of foliage Frozen leaves
- Beet varieties
- Beet stand
- Cultivating job
- Forward speed
- Soil moisture content Height of beds

The operator will have to adjust the machine accordingly.

In soft or wet conditions, the tires will sink into the soil and the machine should be raised to maintain the flail contact point 1/2" below the beet crown.

In conditions where beets extend above the ground and are easily knocked over, adjust flails to contact beet at or just below the crown.

Do not allow the flails to contact the ground. Dirt, stones or other material can be thrown from under the machine.

Running the flails too low causes high flail wear and breakage, higher fuel consumption, and more build up inside the machine. Tall beets may be kicked between rows.



## Operation Continued

### REAR STEERING (Optional)



Figure 24. Rear Steering

Rear wheel steering struts are used when additional maneuverability is required. Tractor must be equipped with a fourth hydraulic control lever if rear steering is to be used.

To operate the rear steering, connect hydraulic hoses so that moving the #4 control lever forward steers the Defoliator to the right and moving the #4 control lever rearward moves the Defoliator to the left.

Use the rear steering system to adjust the offset of the Defoliator for field operation. Ensure that rear steering is “centered” for transport and is tracking directly behind the tractor.

### SCALPERS (Optional)



#### WARNING

- Do not handle blades with bare hands. Careless or improper handling may result in serious injury.

The scalper option available from Alloway is a non-driven, mechanically rotating disc. Scalper lift cylinders operate in parallel with the rear wheel lift cylinders. When raising the rear of the Defoliator, scalper attachments will raise first. When lowering the rear of the Defoliator, scalper attachments will lower last.

### IMPORTANT

- Always raise scalpers before backing up. Scalpers must be fully raised before folding wings.

The disc will rotate to either side and a sharp cutting edge is exposed to do the scalping job. When properly adjusted, it will stay free of debris and consistently cut the required amount of the beet crown.

Uneven beet stands and double beets will cause less than perfect performance. Adjustments should be made to regulate the thickness of the slice to be removed.

Forward speed changes will influence the performance.

In any working position, the disc forward edge of the disc should always be a few degrees lower than the rear edge.

Scalpers are factory pre-set, but need fine adjustment for individual conditions.



#### CAUTION

- Never work on scalper attachment in the raised position. Lower scalpers to the ground and service each unit individually.

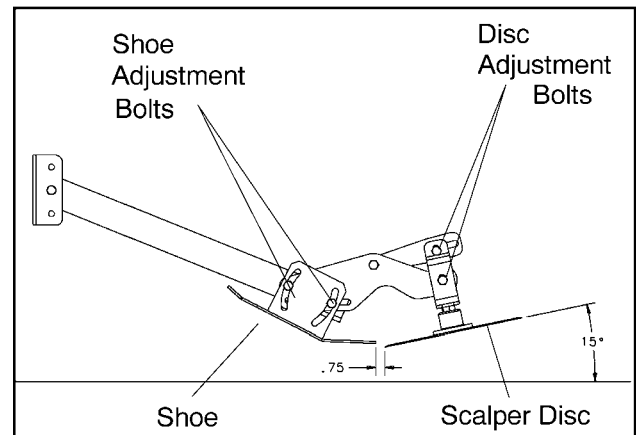


Figure 25. Scalper Adjustment

## Operation Continued

Loosen shoe adjustment bolts and adjust scalper shoe. The trailing surface of the shoe should be nearly horizontal.

Loosen disc adjustment bolts to adjust disc operating pitch. Adjust pitch of scalper disk to slice beets as required.

When adjustments are complete, tighten bolts to specifications in torque chart.



**Figure 26.** Scalper Attachment

## TRANSPORTING THE DEFOLIATOR

When transporting on public roads, wings must be raised to transport position. Follow instructions in "Raising Wings to Transport Position."

Make sure reflector, lights and the SMV sign are clean and clearly visible to other traffic.

Do not allow riders.

Use hazard flashers on the tractor when transporting.

Never exceed safe travel speed. Slow down when making turns and traveling on rough roads or shoulders.

Make sure to use a tractor of sufficient size and with enough front end ballast to assure safe steering.

Lock foot brake pedals for even application during road travel.

## DEFOLIATOR STORED POSITION

Lower wings to operating position and disconnect Defoliator from tractor as described in "Disconnecting Defoliator from Tractor." Defoliator should be in "STORED POSITION" and be supported by park stands, rear wheel/lift cylinder locks, and wing gauge wheels.

Gauge wheel screw jacks may be adjusted to support wings in a level position.

Store Defoliator in an area away from children and bystanders.

Do not allow children to play on or around the stored unit.

Store in a dry, level area.



**Figure 27.** Parking Stand

# OWNER SERVICE

Safety is a primary concern in the design and manufacture of our products. Unfortunately, our efforts to provide safe equipment can be wiped out by an operator's single careless act.

In addition to the design and configuration of equipment, hazard control and accident prevention are dependent upon the awareness, concern, judgement, and proper training of personnel involved in the operation, transport, maintenance and storage of equipment.

It has been said "The best safety device is an informed, careful operator." We ask you to be that kind of operator.

The information in this section is written for the operator who possesses basic mechanical skills. Should you need help, your dealer has trained service technicians available. For your protection, read and follow all safety information in this manual.



## WARNING

■ **Service and maintenance work not covered in OWNER SERVICE must be done by a qualified dealership. Special skills, tools and safety procedures may be required. Failure to follow these instructions can result in serious injury or death.**

■ **Before working underneath a raised implement, read and follow all operator's manual instructions and safety rules. Implement must be attached to tractor, lift cylinder locks must be installed, and lift cylinders lowered against locks. Hydraulic system leak down, hydraulic system failures, or movement of control levers can cause equipment to drop unexpectedly and cause severe injury or death.**

■ **Never perform service or maintenance with engine running.**

■ **Do not disconnect hydraulic lines until engine is stopped, tractor is properly secured, equipment and all components are lowered to the ground, and system pressure is released by operating all valve control levers.**

■ **Keep all persons away from operator control area while performing adjustments, service or maintenance.**

■ **Never go underneath equipment lowered to the ground or raised, unless it is properly blocked and secured. Never place any part of the body underneath equipment or between moveable parts even when the engine has been turned off. Hydraulic system leak down, hydraulic system failures, mechanical failures or movement of control levers can cause equipment to drop or rotate unexpectedly and cause severe injury or death. Follow Operator's Manual instructions for working underneath and blocking requirements, or have work done by a qualified dealer.**



## CAUTION

■ **Always wear relatively tight and belted clothing to avoid entanglement in moving parts. Wear sturdy, rough-soled work shoes and protective equipment for eyes, hair, hands, hearing and head.**

## BLOCKING METHOD

Do not work underneath the Defoliator unless it is properly attached to the tractor and blocked securely. When properly attached, the unit will be anchored to minimize front-to-rear movement. Do not work on Defoliator with wings in any intermediate position.

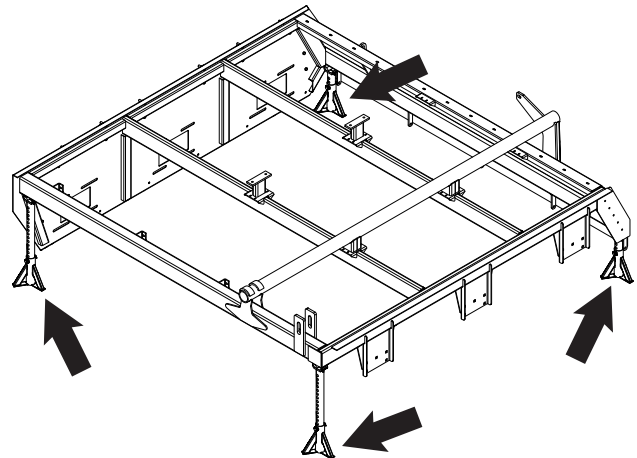


Figure 28 Jackstand Locations

For any service work which requires working underneath the Defoliator, the following blocking instructions must be followed.

The Defoliator must be properly attached to a tractor located on a hard level surface.

## Owner Service Continued

The Defoliator wings must be lowered into operating position with wing gauge wheels adjusted to support the wings during service.

Front and rear cylinder locks must be properly installed. Do not use a cylinder lock or retaining pin which is bent or damaged. Replace any damaged or lost cylinder lock components immediately.

Jackstands, with a minimum load rating of 4000 lbs each, must be placed under the wing frames at each corner of the right and left wings as shown in Figure 28. Jackstands should be adjusted so that they securely support the Defoliator during service.

Tractor park brake must be engaged, wheels chocked, and PTO shaft disconnected from the tractor.

## LUBRICATION

### GEARBOX OIL

Use 80W90 gear lube. Capacity: 2 US quarts.

### GREASING

Use a multi-purpose high temperature grease.

**Note:** Over-greasing can cause damage to bearing seals.

- Use hand held grease gun to avoid blown seals.
- Wipe grease fittings clean to avoid contamination.
- Replace or repair broken fittings immediately.
- If fittings do not take grease, remove zerk, and clean passageway.

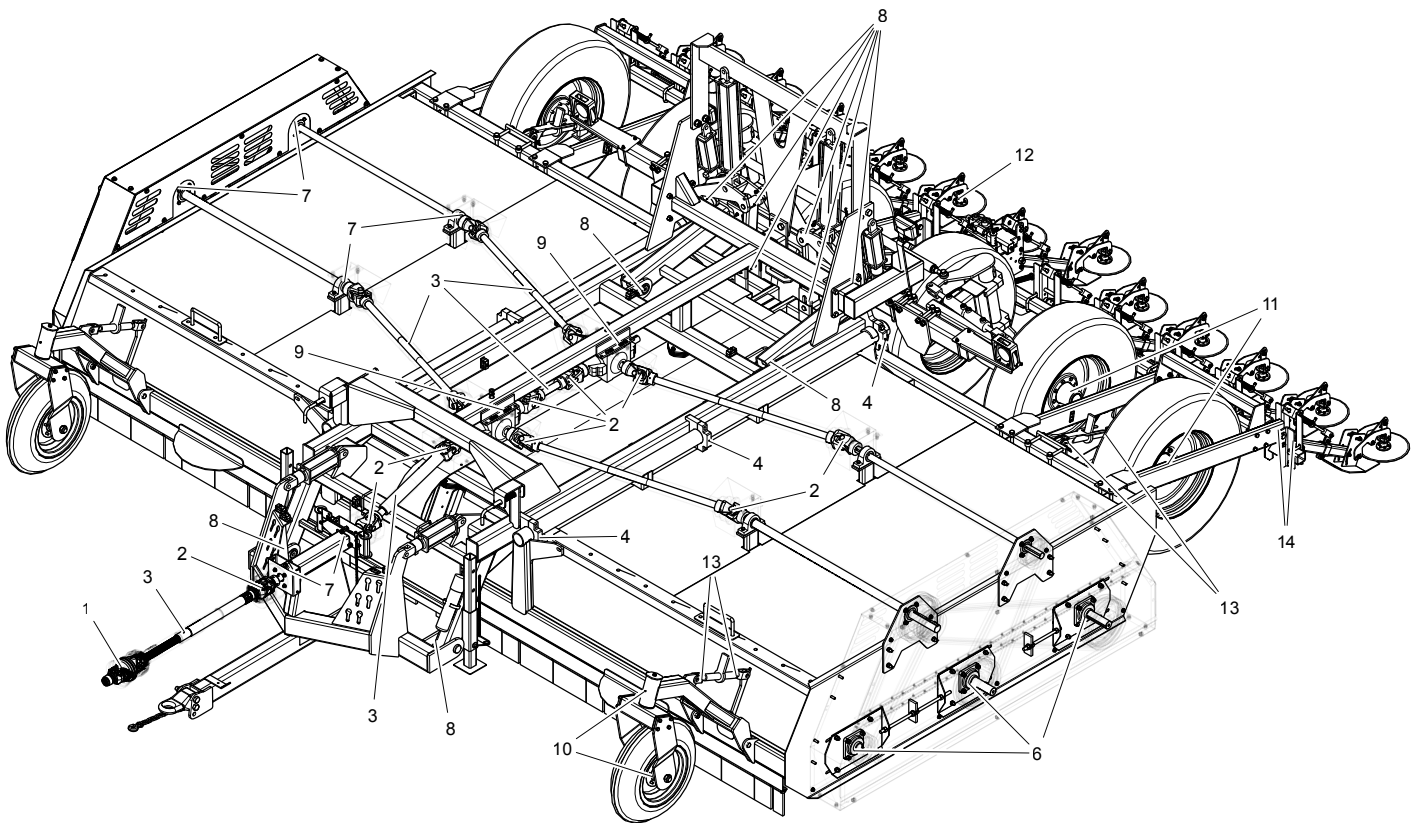


Figure 30. Lubrication Points

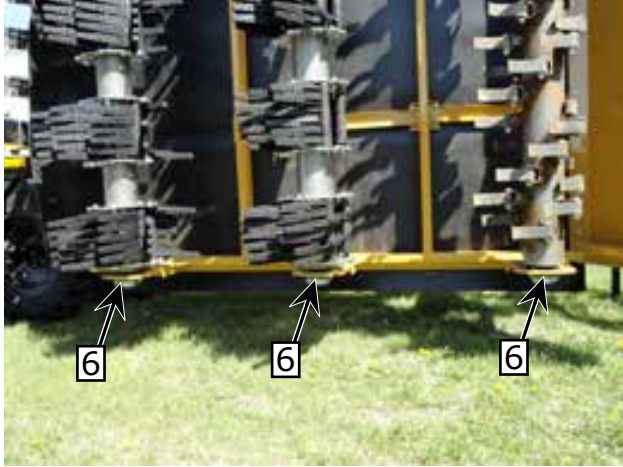


# Owner Service *Continued*

## Sealed Bearing Information (Figure 29)

Moisture and contaminants can be trapped behind the bearing seals.

Usually a single pump of a hand held grease gun every 40 hours of operation will be sufficient to force moisture out and relube the bearing. Please keep this in mind when greasing line shaft or rotor bearings on the Defoliator.



**Figure 29. Inside Rotor Bearings Grease Intervals**

### 10 Hours

1. Grease CV PTO portion of the driveline.
2. Grease PTO driveline with regular universals and shield zerks.

### 20 Hours

3. Grease all telescoping drive shafts on top of the machine including shield zerks.
4. Grease wing hinge points and all lift arm linkages.

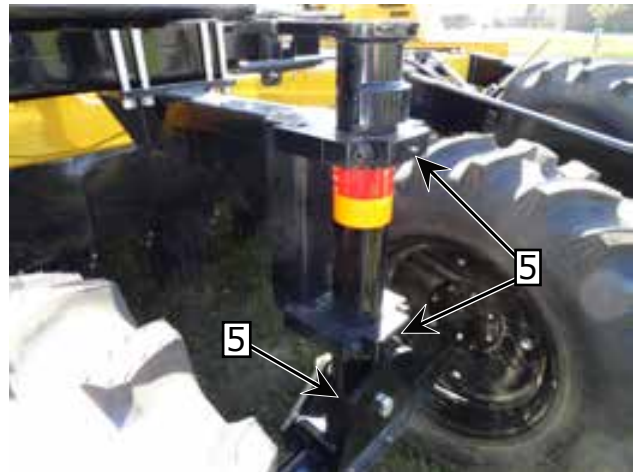
### 40 Hours

5. Grease rear steering pivots (Figure 31).
6. Grease all rotor bearings (Figure 29, 30).
7. Grease all line shaft bearings.
8. Grease hitch and rear carrier hinge points.

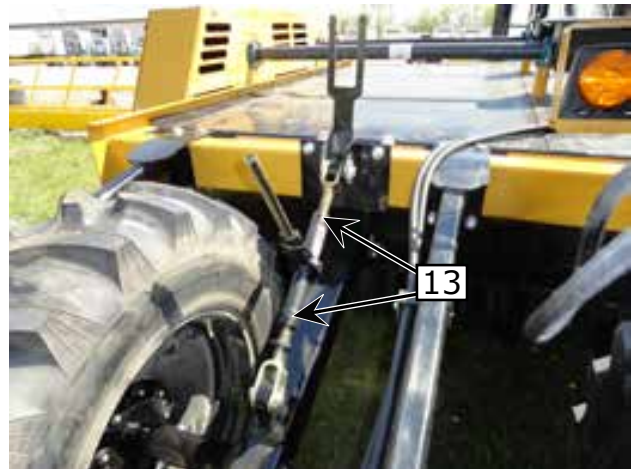
## Annually

9. Change oil in gearboxes / Clean breathers
10. Grease Stabilizer Wheel
11. Grease carrier wheel bearings.
12. Inspect scalper bearings.
13. Grease gauge wheel jack screws (Figure 30, 32).
14. Grease Scalper Pivots.

Grease all zerks after washing and at outset or end of season to remove potential moisture from bearings.



**Figure 31. Rear Steering Pivots**



**Figure 32. Gauge Wheel Jack Screws**

## MAINTENANCE

### DRIVE BELTS

#### Belt Tension

Banded drive belts are used to transmit power to the rotor shafts. Improperly adjusted belts will create heat which results in poor performance and fast belt wear. It is wise to check belts every 4 to 5 hours, if they feel cool to touch, they are adjusted well. Any high heat should signal a need for adjustment.

**Note:** Heat buildup can also be caused by running flails too close to the ground or excessive build up inside the Defoliator.

#### Adjusting Belt Tension (Figure 33)

Stop tractor engine, put all controls in neutral, remove ignition key, and wait for all moving parts to stop before dismounting.

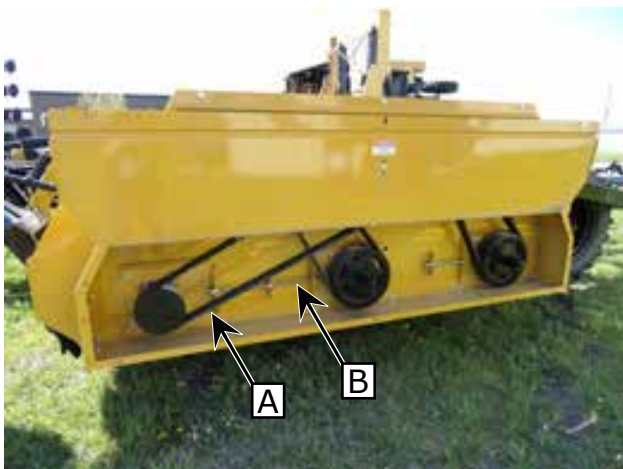
Open and secure lower belt housing shields.

Loosen bearing plate anchor bolts (A).

Adjust nuts on tightener rod (B) until proper tension is reached.

Retighten bearing plate (A).

Close and secure belt housing shields.



**Figure 33.** Belt Tension Adjustment - Belt Box

#### Replacing Drive Belts (Figure 33 & Figure 34)

Stop tractor engine, put all controls in neutral, remove ignition key, and wait for all moving parts to stop before dismounting.

Open and secure lower belt housing shields.

Loosen bearing plate anchor bolts (A).

Loosen nuts on tightener rod and bring rotor shaft to the extreme loose position.

Replace belt on sheaves as shown in Figure 33 and Figure 34.

Adjust nuts on tightener rod (B) until proper tension is reached.

Retighten bearing plate (A).

Close and secure belt housing shields



**Figure 34.** Rotor Upper Drive Pulleys

## Owner Service *Continued*

### FLAIL REPLACEMENT

Securely block-up the Defoliator as described in "Blocking Method for Defoliator Service," Figure 28.



### WARNING

■ Never walk, stand or place yourself or others under a raised wing or in the path of a lowering wing. Hydraulic system leak down, hydraulic system failures, mechanical failures or movement of control levers can cause wings to drop unexpectedly and cause severe injury or death.

### IMPORTANT

■ Always replace opposite pairs of knives and mounting hardware to maintain rotor balance. Replace any broken or missing knife immediately.



**Figure 35.** Flail Assembly

### L-Knife/Cup

Remove bolt from flail bracket and remove flail.

Replace flail bushing and tighten bolt to specifications in Torque Chart.

### Rubber Flail

Rubber flails are attached to adjustable flail heads, which are clamped to the rotor.

To replace rubber flails, remove flail pin retaining bolt and withdraw pin. Remove flail assembly as a unit. Head clamping bolts may need to be loosened to make disassembly easier.

Note location of flails, spacers and bushings. Replace any worn, damaged or missing components in their correct location. Insert flail pin through assembly and install retaining bolt. Tighten flail pin retaining bolt to specifications in Torque Chart.

Inspect flail heads to determine that they are securely clamped to rotor. If flail heads are not attached securely, tighten clamping bolts to specifications in Torque Chart.

# TROUBLE SHOOTING

The Alloway Folding Defoliator uses rubber or steel flails on drums to remove foliage from the tops of sugar beets. It is a simple and reliable system that requires minimal maintenance. The following table lists problems, causes, and solutions that you may

encounter. If you encounter a problem that is difficult to solve even after reading through this table, please call your local Alloway dealer. When calling, please have this manual and your unit's serial number ready.

PROBLEM	POSSIBLE CAUSE	SOLUTION
Drums won't turn	Tractor PTO defective	Repair tractor PTO
	Broken cross shaft or drive coupler on central hanger bearing	Replace (9 or 12 row units only)
Rapid belt wear	Machine plugged	Unplug machine
	Pulleys out of alignment	Align pulleys
	Loose or overtightened belts	Adjust belt tension
	Overloaded/Running too low	Raise unit or slow down
Flails breaking	Machine too low	Raise machine
	Hitting rocks or other debris	Clean field better before planting
Tires don't turn	Mud buildup	Adjust tire pressure to 15-20 psi
Beet crown not clean	Machine too high	Lower the machine
	Flails broken	Replace broken flails
	Traveling too fast	Slow down
	Running slow (tractor)	Increase speed to rated PTO RPM
	Need a scalper	Install and set scalper
	Scalper bounces	Increase scalper spring tension
Beets are pulled out of the ground	Machine too low	Raise machine
	Machine too slow	Increase ground speed
	Scalper pulling beets out of ground	Adjust scalper
Defoliator vibrates	Driveline doesn't telescope	Remove, disassemble, and clean telescoping joint
		Balance tube
	Flail tube out of balance	Replace missing knives or rubber flails. Always replace in pairs 180 degrees apart.



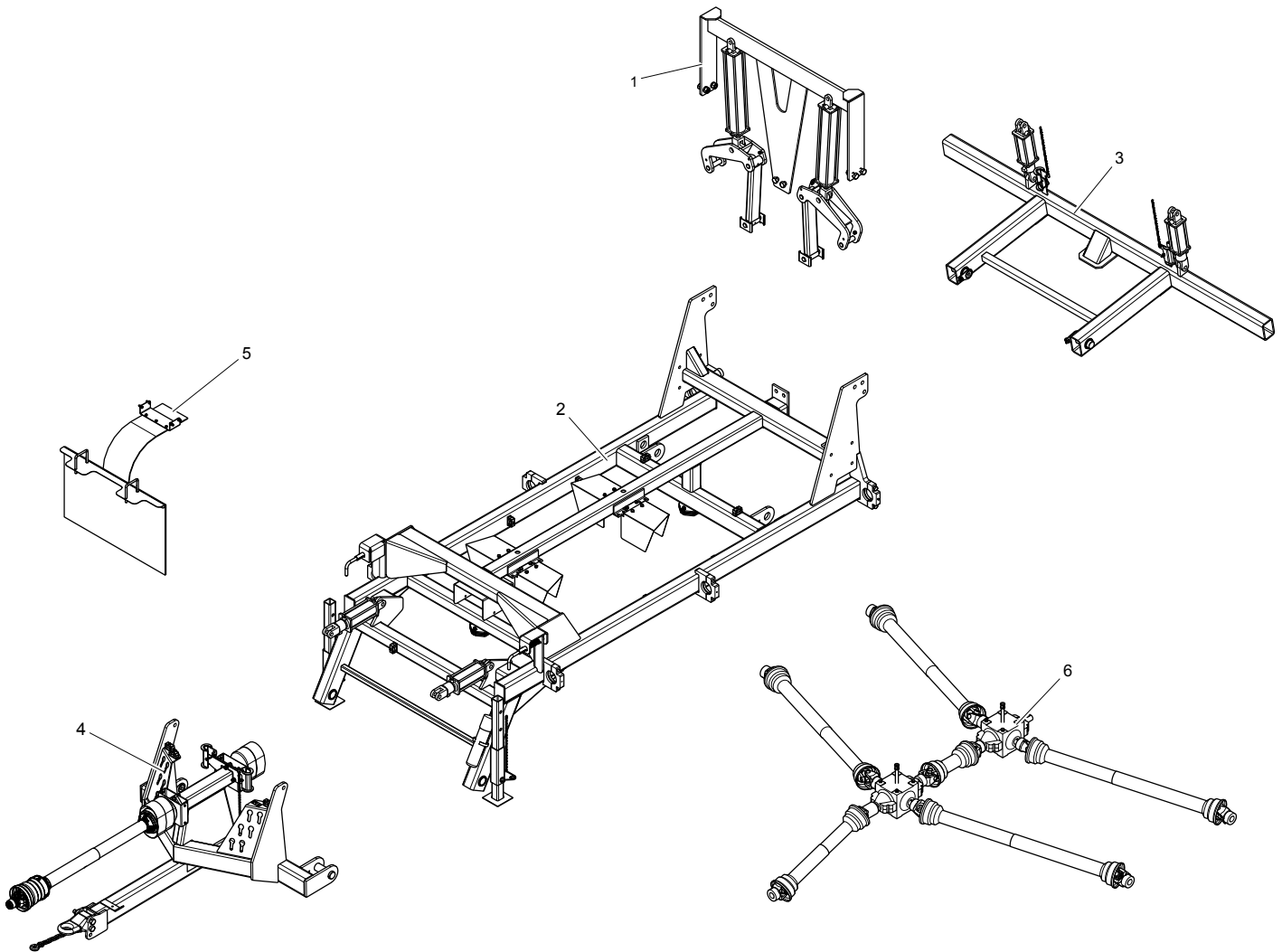


# PARTS INDEX

## FOLDING DEFOLIATOR

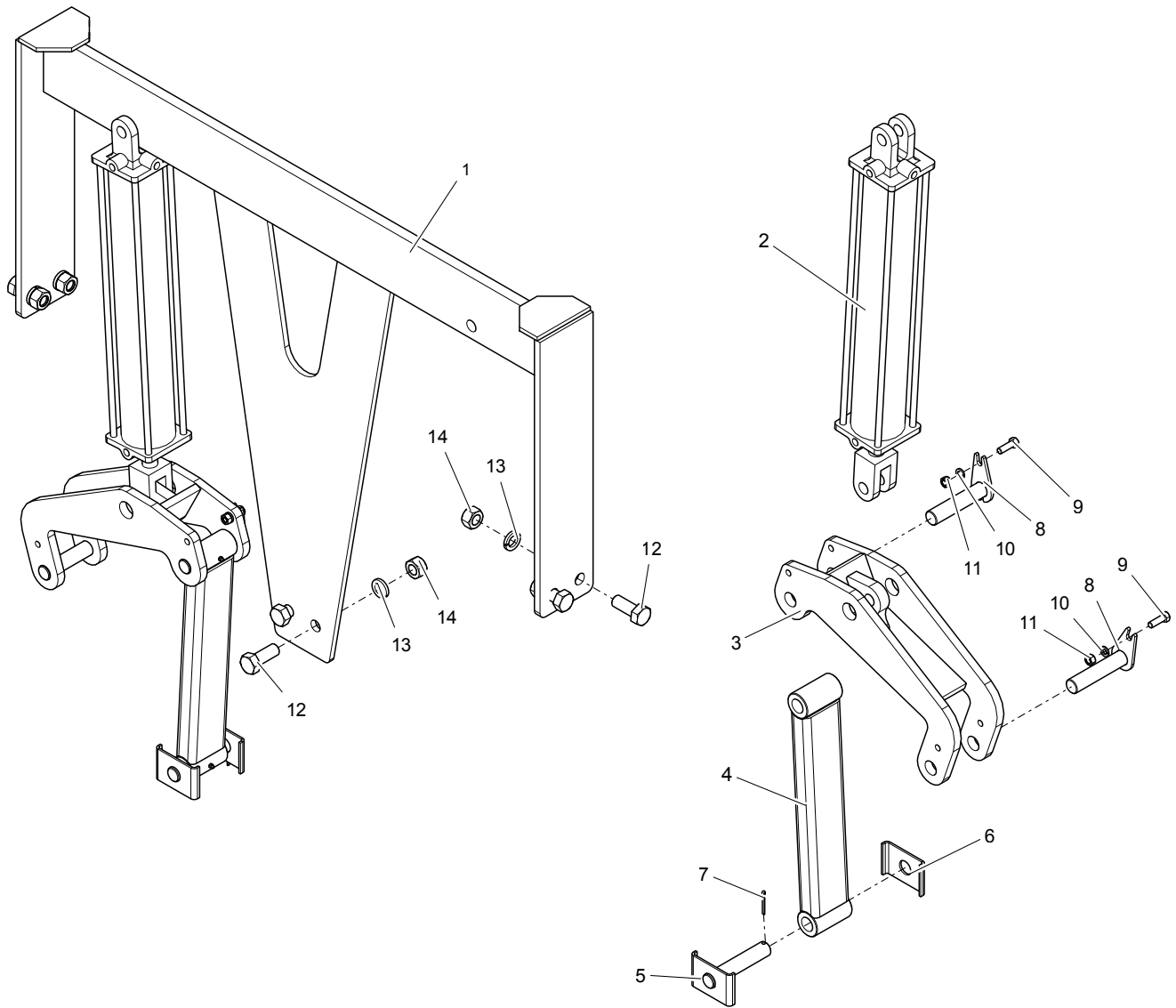
FRAME COMPONENTS .....	36 - 42
TOP BAR .....	37
CENTER FRAME .....	38
STRUT MOUNT .....	39
HITCH .....	40
MUD FLAP .....	41
DRIVE .....	42
WING COMPONENTS .....	43 - 47
WING SHIELD .....	43
WING FRAME .....	44 - 45
WING COVER .....	46
BELT ASSEMBLY .....	47
WING STRUT COMPONENTS .....	48
FLAIL COMPONENTS .....	49
FIXED STRUT COMPONENTS .....	50 - 51
STEERABLE STRUT COMPONENTS .....	52 - 53
ROW FINDER COMPONENTS .....	54 - 55
TOOLBAR ROW FINDER COMPONENTS .....	56 - 57
SCALPER ROW FINDER COMPONENTS .....	58 - 59
ROW FINDER PARALLEL LINK MOUNT COMPONENTS .....	60 - 63
HYDRAULIC COMPONENTS .....	64 - 65
REAR STEER HYDRAULIC COMPONENTS .....	66
ROW FINDER HYDRAULIC COMPONENTS .....	67
WING LIFT HYDRAULIC COMPONENTS .....	68
HUB & SPINDLE COMPONENTS .....	69
GEARBOX - SUPERIOR (4-WAY) .....	70
JUMP DRIVE SHAFT COMPONENTS .....	71
1-3/8" PTO WWCV DRIVE SHAFT COMPONENTS .....	72
1-3/4" PTO WWCV DRIVE SHAFT COMPONENTS .....	73
WING DRIVE SHAFT COMPONENTS .....	74
HITCH EXTENSION DRIVE SHAFT COMPONENTS .....	75
SCALPER TOOLBAR COMPONENTS (STRAIGHT ARM) .....	76 - 77
SCALPER TOOLBAR COMPONENTS (PARALLEL LINK) .....	78 - 79
CIRCULAR KNIFE SCALPER - STRAIGHT ARM .....	80
STRAIGHT KNIFE SCALPER - PARALLEL LINK .....	81
CIRCULAR KNIFE SCALPER - PARALLEL LINK .....	82
STABILIZER WHEEL COMPONENTS .....	83
LIGHT COMPONENTS .....	84

# FRAME COMPONENTS - COMPLETE ASSEMBLY



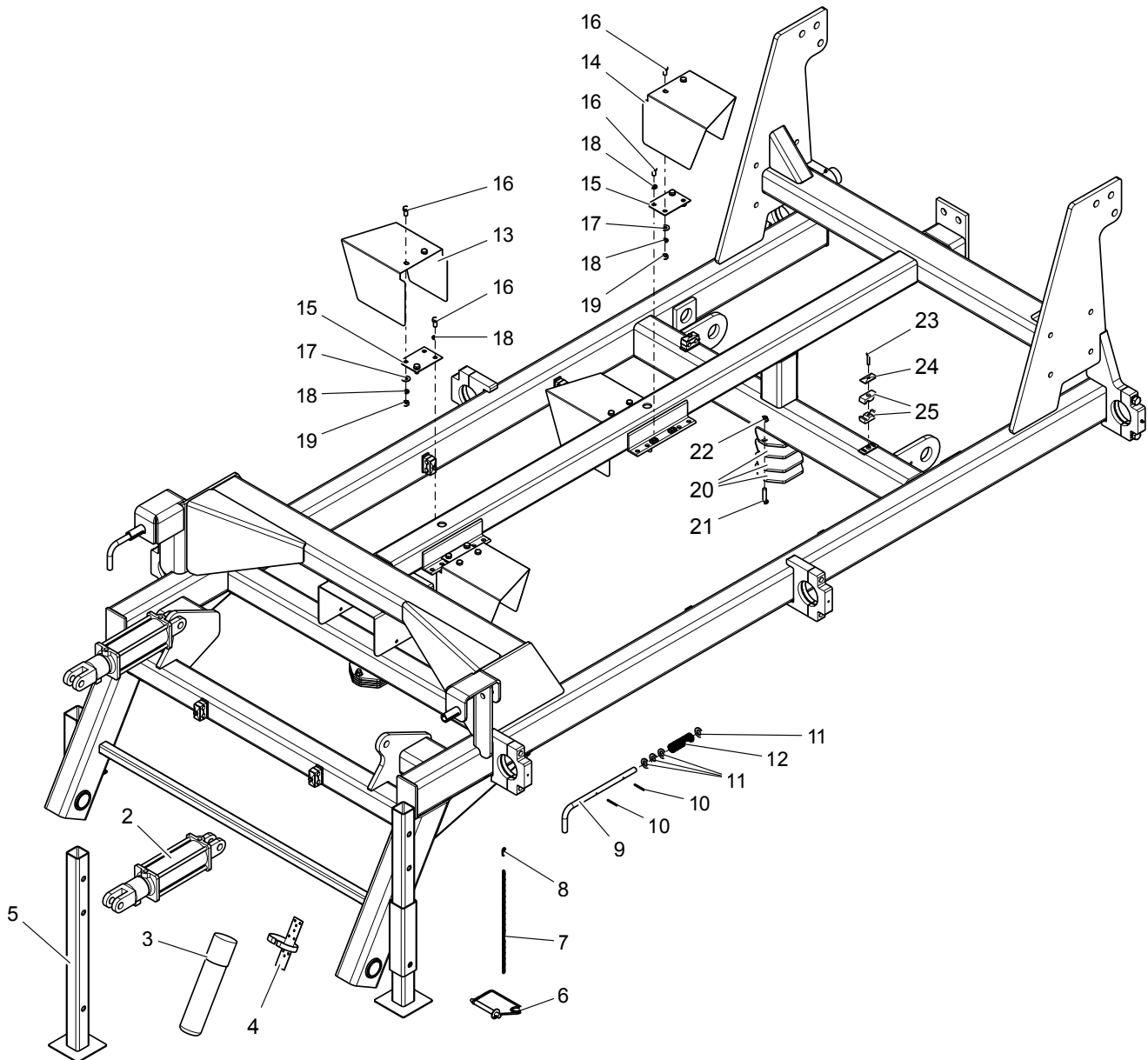
ITEM NO.	PAGE NUMBER	DESCRIPTION
1	37	TOP BAR SECTION
2	38 - 39	CENTER FRAME SECTION
3	39	STRUT MOUNT SECTION
4	40	HITCH SECTION
5	41	MUD FLAP SECTION
6	42	DRIVE SECTION

## FRAME COMPONENTS - TOP BAR SECTION



ITEM NO.	PART NUMBER	DESCRIPTION	QTY.
1	500-2-0661	TOP BAR WELD	1
2	905-21417	CYLINDER, 4 X 24 W/ 3/4-16 ORB PORTS	2
	905-21415	SEAL KIT, 4 X 24	
3	500-2-0662	LINK ARM WELD	2
4	500-2-0954	PIVOT TUBE WELD	2
5	500-2-0685	CHANNEL PIN WELD	2
6	500-3-1510	CHANNEL PIN CAP	2
7	900-23045	PIN, COTTER 3/16 X 2	2
8	500-2-0684	PIN WELD, 1-1/4	4
9	900-01225	BOLT, HEX HEAD 1/2 X 1-1/2, GR5 ZP	4
10	900-11013	WASHER, LOCK 1/2	4
11	900-06009	NUT, HEX HEAD 1/2	4
12	900-01515	BOLT, HEX HEAD 1 X 2-1/2, GR5 ZP	6
13	900-11021	WASHER, LOCK 1	6
14	900-06019	NUT, HEX HEAD 1	6

## FRAME COMPONENTS - CENTER FRAME SECTION

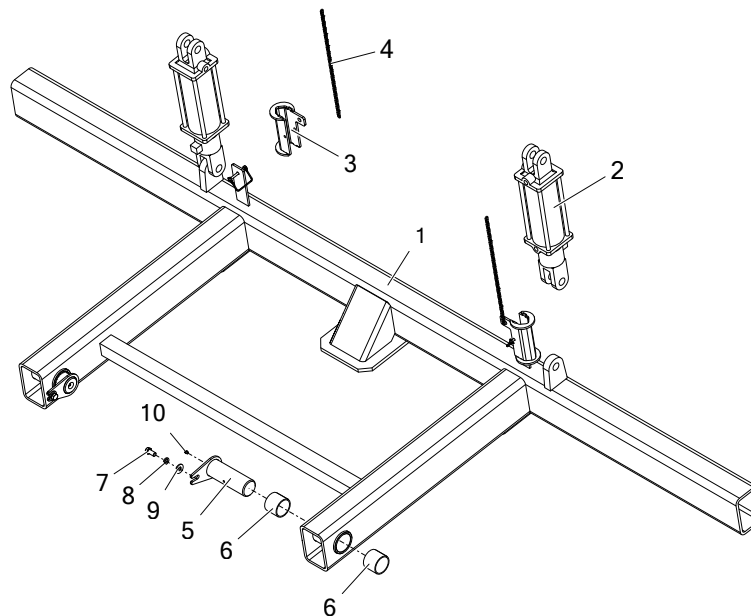


ITEM NO.	PART NUMBER	DESCRIPTION	QTY.
1	500-2-0664	CENTER FRAME WELDMENT	1
2	905-21400	CYLINDER, 3-1/2 X 8 W/ DEPTH STOP	2
	905-21380	SEAL KIT, 3-1/2 X 8 ( <i>PRINCE CYLINDERS ONLY</i> )	
	905-21401	SEAL KIT, 3-1/2 X 8 ( <i>MONARCK CYLINDERS ONLY</i> )	
3	100-3-3957	MANUAL STORAGE TUBE	1
4	100-3-3958	MANUAL TUBE BRACKET	1
5	500-2-0658	MAINFRAME STAND	2
6	900-42054	SNAP LOCK CLEVIS PIN, 5/8 x 4	2
7	500-3-2858	RETAINING CHAIN, 36 LINKS	2
8	900-42051	QUICK LINK, 1/8	2
9	500-3-2749	WING LOCK PIN	2
10	900-29138	ROLL PIN, 3/16 x 2	2
11	900-11038	WASHER, FLAT, 3/4	8

## FRAME COMPONENTS - CENTER FRAME SECTION

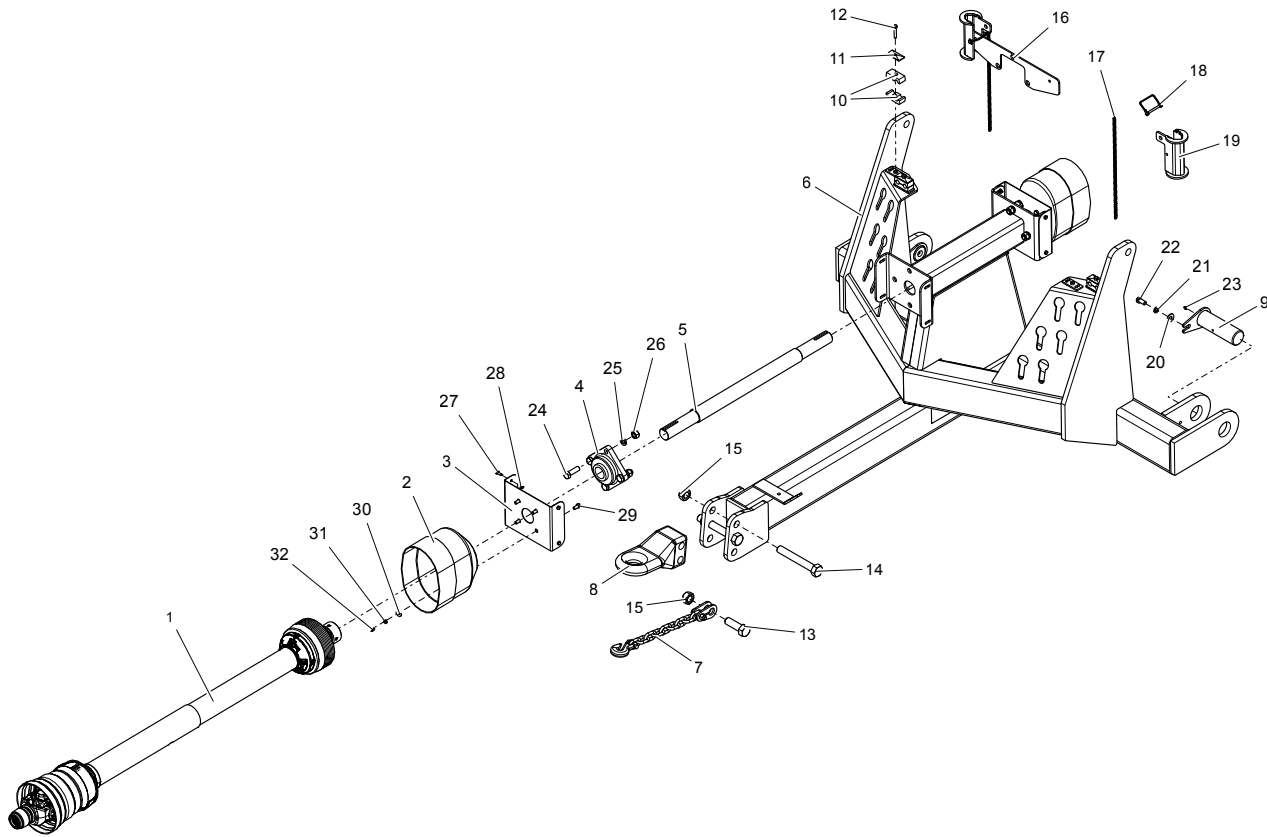
ITEM NO.	PART NUMBER	DESCRIPTION	QTY.
12	905-14022	LOCK PIN SPRING	2
13	500-3-1679	GEARBOX SHIELD (RH)	2
14	500-3-1680	GEARBOX SHIELD (LH)	2
15	500-3-1684	RUBBER HINGE	4
16	900-01221	BOLT, 1/2 NC x 1	16
17	900-11035	WASHER, FLAT, 1/2	8
18	900-11013	WASHER, LOCK, 1/2	16
19	900-06009	NUT, 1/2 NC	8
20	500-3-2621	SPACER PLATE	6
21	900-01754	BOLT, CARRIAGE, 1/2 NC x 2-1/4	4
22	900-06143	NUT, SPIRALOCK, 1/2 NC	4
23	900-02356	BOLT, 5/16 NC x 1-3/4	10
24	900-31068	TOP PLATE	10
25	900-31069	BODY CLAMP, 3/8	20

## FRAME COMPONENTS - STRUT MOUNT SECTION



ITEM NO.	PART NUMBER	DESCRIPTION	QTY.
1	500-2-0659	STRUT MOUNT WELDMENT	1
2	905-21400	CYLINDER, 3-1/2 X 8 W/ DEPTH STOP	2
	905-21380	SEAL KIT, 3-1/2 X 8 ( <b>PRINCE CYLINDERS ONLY</b> )	
	905-21401	SEAL KIT, 3-1/2 X 8 ( <b>MONARCK CYLINDERS ONLY</b> )	
3	700-2-0159	CYLINDER STOP	2
4	500-3-2858	RETAINING CHAIN	2
5	500-2-0748	PIN WELDMENT	2
6	901-01318	BUSHING, 2-1/4 X 2-1/2 X 2, SPLT B	4
7	900-01221	BOLT, 1/2 NC X 1	2
8	900-11013	WASHER, LOCK, 1/2	2
9	900-11035	WASHER, FLAT, 1/2	2
10	905-15024	ZERK, 1/4-28	2

## FRAME COMPONENTS - HITCH SECTION

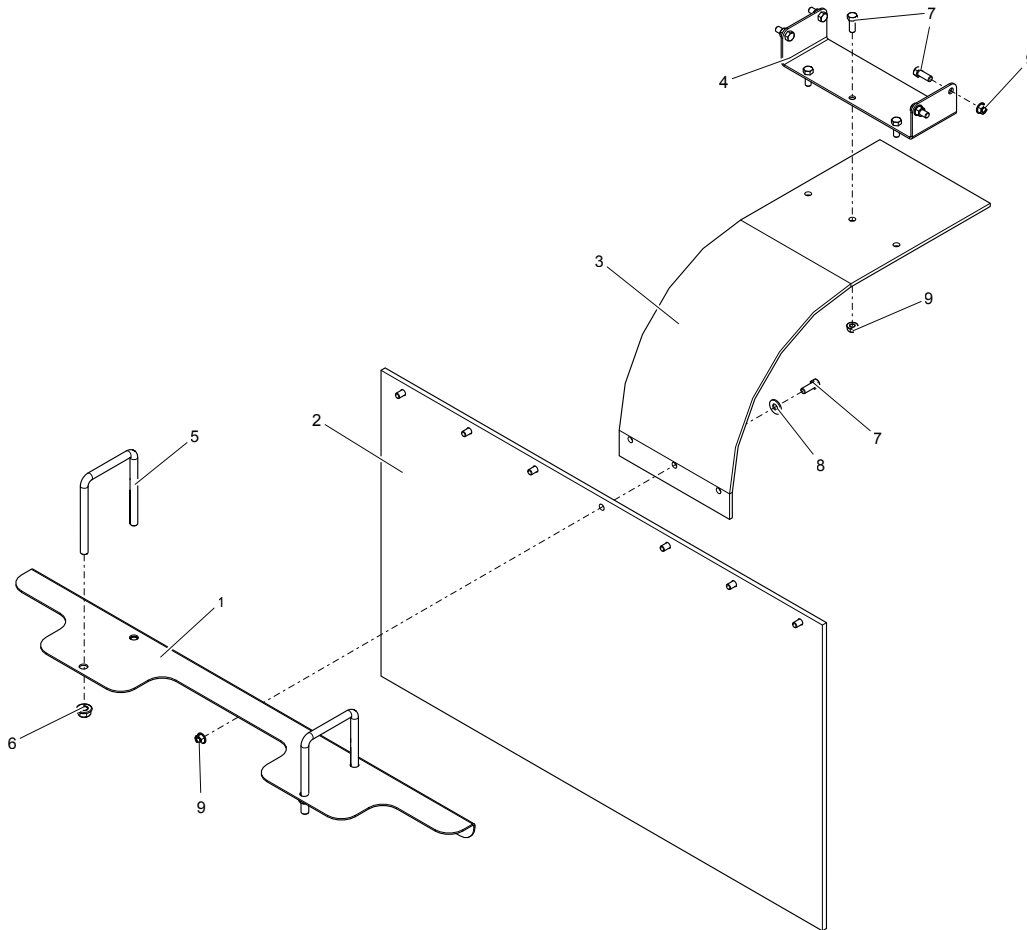


ITEM NO.	PART NUMBER	DESCRIPTION	QTY.
1	905-18411	SHAFT, PTO DRIVE 1-3/4	1
	905-18412	SHAFT, PTO DRIVE 1-3/8	1
2	903-18007	PTO BELL	2
3	500-3-2164	GUARD BRACKET	2
4	901-01185	BEARING 1-3/4 (107022)	2
5	500-3-2742	SHAFT, PTO TRANSFER	1
6	500-2-1336	HITCH WELDMENT	1
7	905-07123	CHAIN, SAFETY TOW (21,000 LB)	1
8	505-3-0831	HITCH TONGUE (CAT-3)	1
9	700-2-0019	PIN WELD	2
10	900-31069	HOSE CLAMP BODY	
11	900-31068	TOP PLATE, CLAMP BODY	
12	900-02356	BOLT, 5/16 NC x 1-3/4	3
13	900-01519	BOLT, 1 NC x 3	1
14	900-02930	BOLT, 1 NC x 7	2
15	900-06514	NUT, LOCK, 1 NC	3
16	500-3-2847	TRANSPORT LOCK HOLDER	1
17	500-3-2858	RETAINING CHAIN	2
18	900-42055	SQ SNAP RETAINING PIN, 1/4 x 2-1/4	2
19	700-2-0159	CYLINDER STOP	2
20	900-11035	WASHER, FLAT, 1/2	2
21	900-11013	WASHER, LOCK, 1/2	2
22	900-01221	BOLT, 1/2 NC x 1	2
23	905-15024	GREASE ZERK, 1/4-28	2

## FRAME COMPONENTS - HITCH SECTION

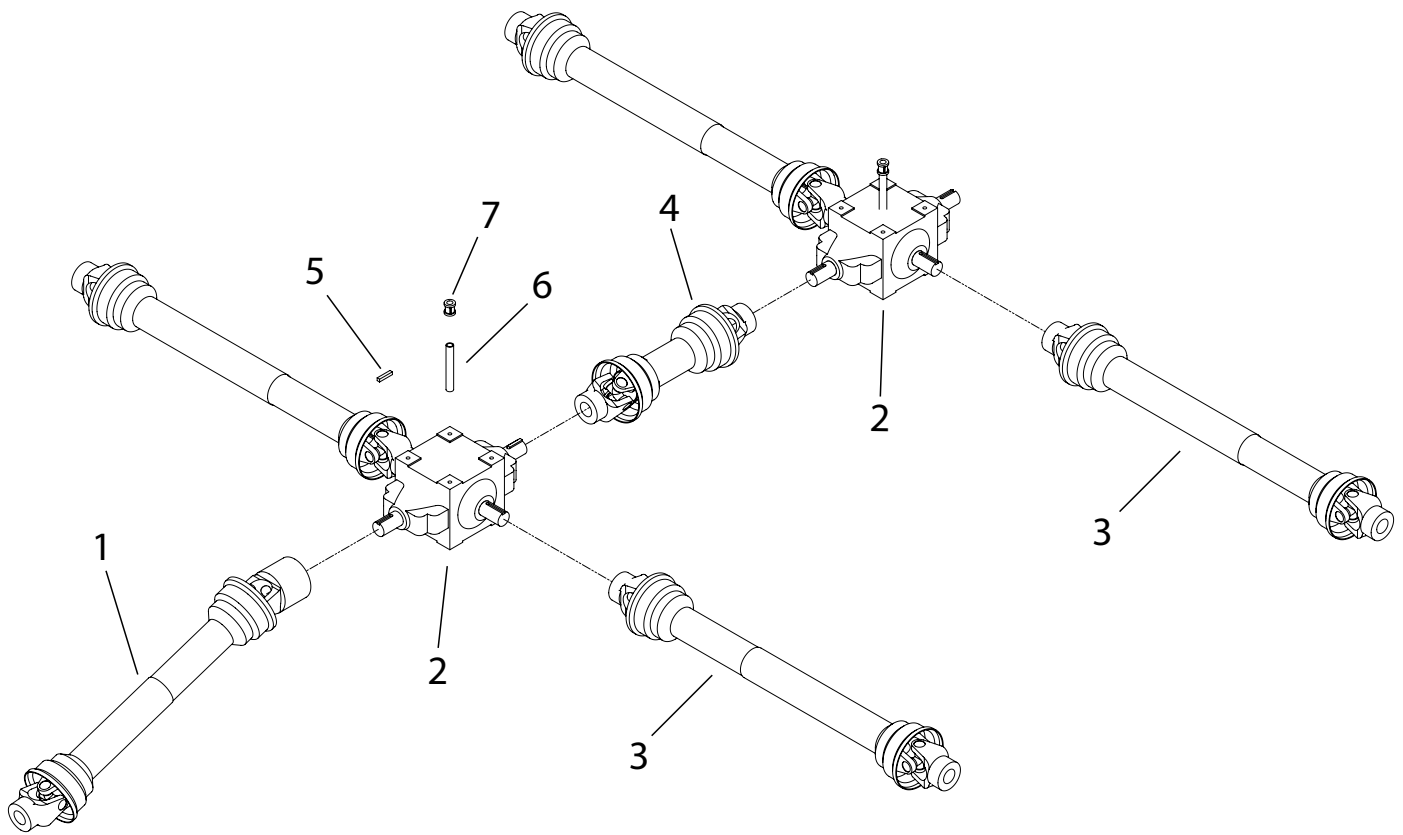
ITEM NO.	PART NUMBER	DESCRIPTION	QTY.
24	900-01345	BOLT, 5/8 NC x 2	8
25	900-11015	WASHER, LOCK, 5/8	8
26	900-06013	NUT, 5/8 NC	8
27	900-01005	BOLT, 1/4 NC x 3/4	8
28	900-06135	NUT, SPIRALOCK, 1/4 NC	8
29	900-01105	BOLT, 3/8 NC x 3/4	8
30	900-11033	WASHER, FLAT, 3/8	8
31	900-11011	WASHER, LOCK, 3/8	8
32	900-06005	NUT, 3/8 NC	8

## FRAME COMPONENTS - MUD FLAP SECTION



ITEM NO.	PART NUMBER	DESCRIPTION	QTY.
1	500-3-2211	FRONT FLAP MOUNT	1
2	700-3-1220	RUBBER FLAP	1
3	500-3-2238	DEFLECTOR SHIELD - DIVIDER	1
4	500-3-2237	DEFLECTOR SHIELD MOUNT	1
5	100-3-2582	U-BOLT 1/2 X 4 X 5.5	2
6	900-06143	NUT, SPIRALOCK FLANGE 1/2	4
7	900-06139	NUT, SERR FLANGE 3/8	14
8	900-11033	WASHER, FLAT 3/8	7
9	900-01109	BOLT, HEX HEAD 3/8 X 1, GR5 ZP	14

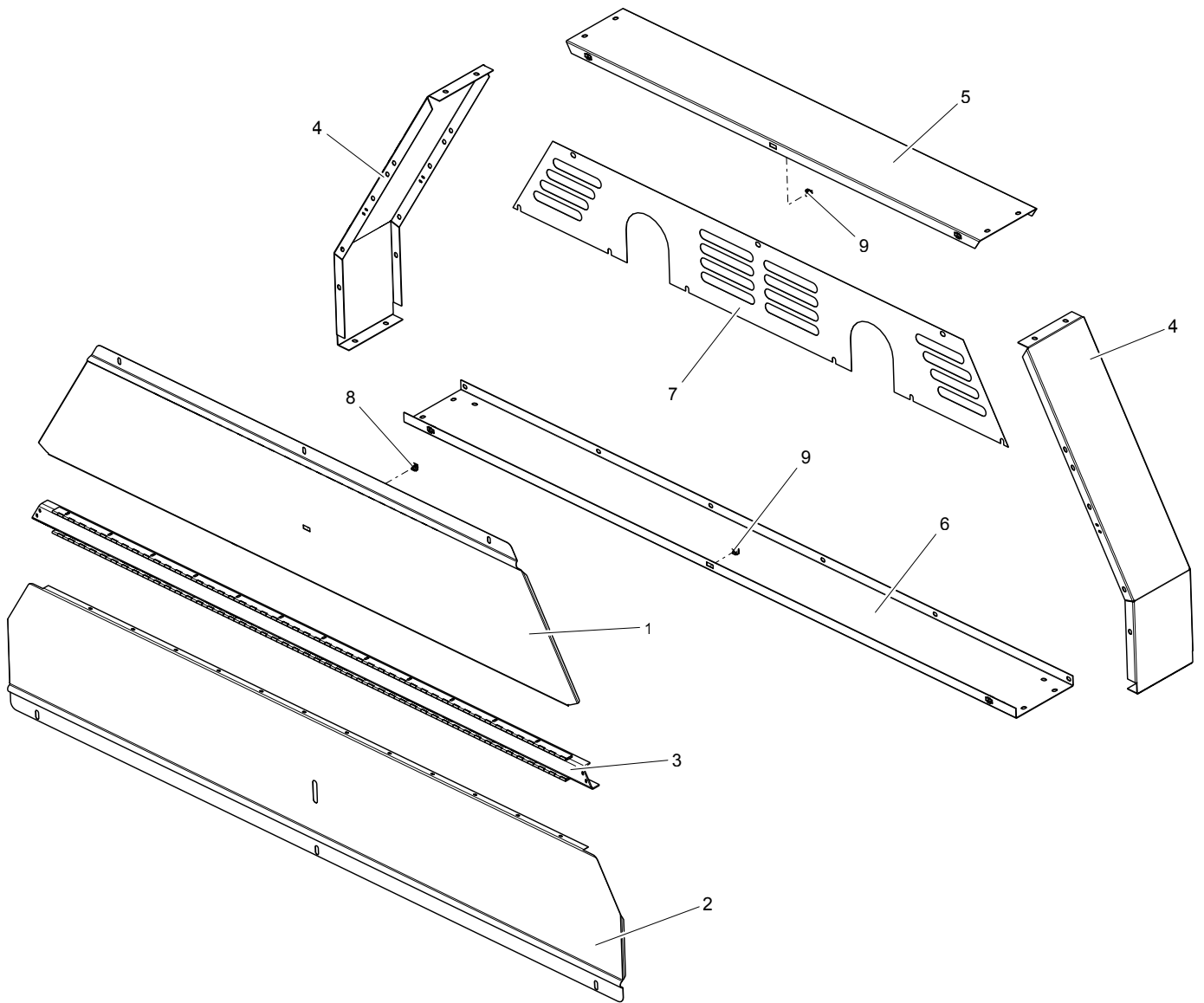
## FRAME COMPONENTS - DRIVE SECTION



ITEM NO.	PART NUMBER	DESCRIPTION	QTY.
1	903-18308	HITCH EXTENSION DRIVE SHAFT	1
2	903-15560	GEARBOX, SUPERIOR R-600 (1:1.35 GEAR RATIO)	2
3	903-18055	WING DRIVE SHAFT	4
4	903-18198	JUMP DRIVE SHAFT	1
5	100-3-3333	KEY 3/8 X 3/8 X 2	12
6	905-01238	NIPPLE, 1/2 NPT X 6 (GALVANIZED)	2
7	905-01189	COUPLING 1/2 NPT (STAINLESS STEEL)	2

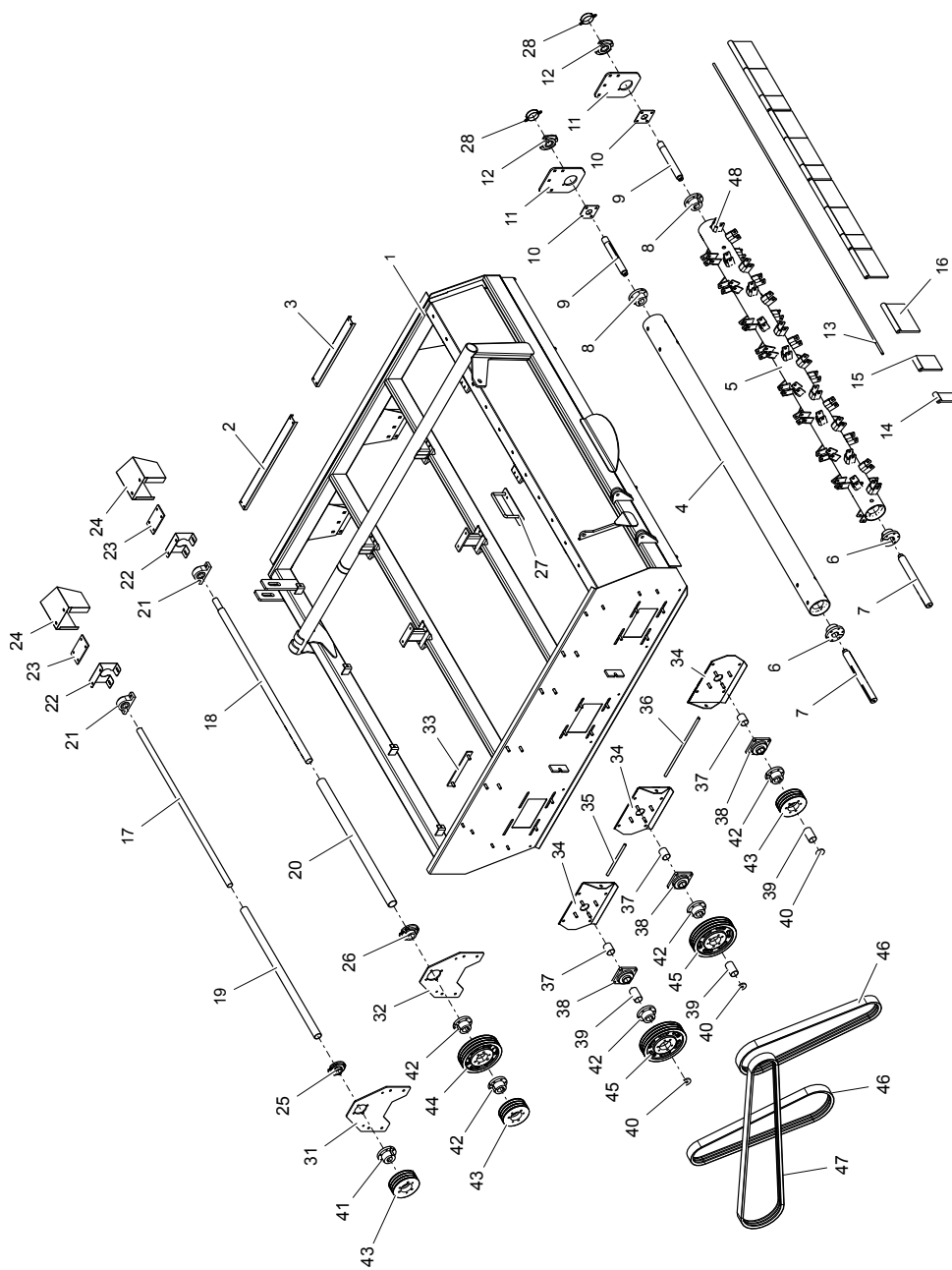


## WING SHIELD COMPONENTS



ITEM NO.	PART NUMBER	DESCRIPTION	QTY.
1	500-3-2328	TOP DOOR	1
2	500-3-2327	BOTTOM DOOR	1
3	500-2-0955	DOOR HINGE	1
4	500-3-2109	SIDE SHIELD	2
5	500-3-2111	TOP SHIELD	1
6	500-3-2110	BOTTOM SHIELD	1
7	500-3-1632	BACK SHIELD	1
8	900-06630	CLIP-ON NUT, 1/2-13 (DOOR ONLY)	1
9	900-06631	CLIP-ON NUT, 1/2-13 (SHIELD ONLY)	6
	500-2-1277	WING SHIELD (COMPLETE)	-

# WING FRAME COMPONENTS

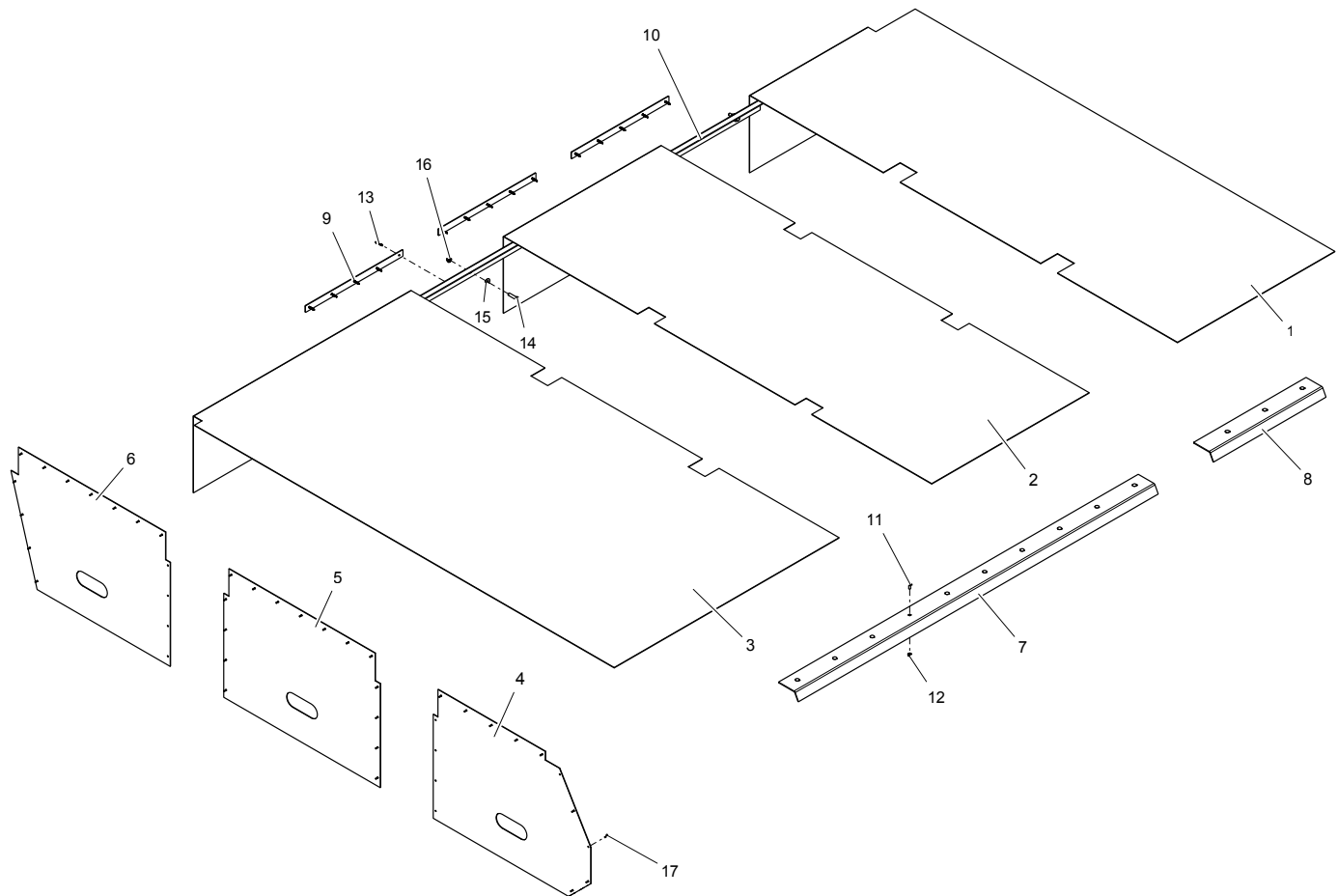


ITEM NO.	PART NUMBER	DESCRIPTION	QTY.
1	500-2-0674	WING WELDMENT - 12R22 (RH)	1
	500-2-1247	WING WELDMENT - 12R20/8R30 (RH)	
	500-2-0673	WING WELDMENT - 12R22 (LH)	
	500-2-1263	WING WELDMENT - 12R20/8R30 (LH)	
	500-2-1262	KNIFE FLAIL DRUM - 12R20/8R30 (RH)	
2	500-3-2380	COVER SPLICE CHANNEL (BACK)	2
	500-3-2379	COVER SPLICE CHANNEL (FRONT)	
4	500-2-1118	SMOOTH FLAIL DRUM - 12R22	1
	500-2-1261	SMOOTH FLAIL DRUM - 12R20/8R30	
5	500-2-1124	KNIFE FLAIL DRUM - 12R22 (RH)	1
	500-2-1262	KNIFE FLAIL DRUM - 12R20/8R30 (RH)	
	500-2-1129	KNIFE FLAIL DRUM - 12R22 (LH)	
	500-3-1734	KNIFE FLAIL DRUM - 12R20/8R30 (LH)	

## WING FRAME COMPONENTS

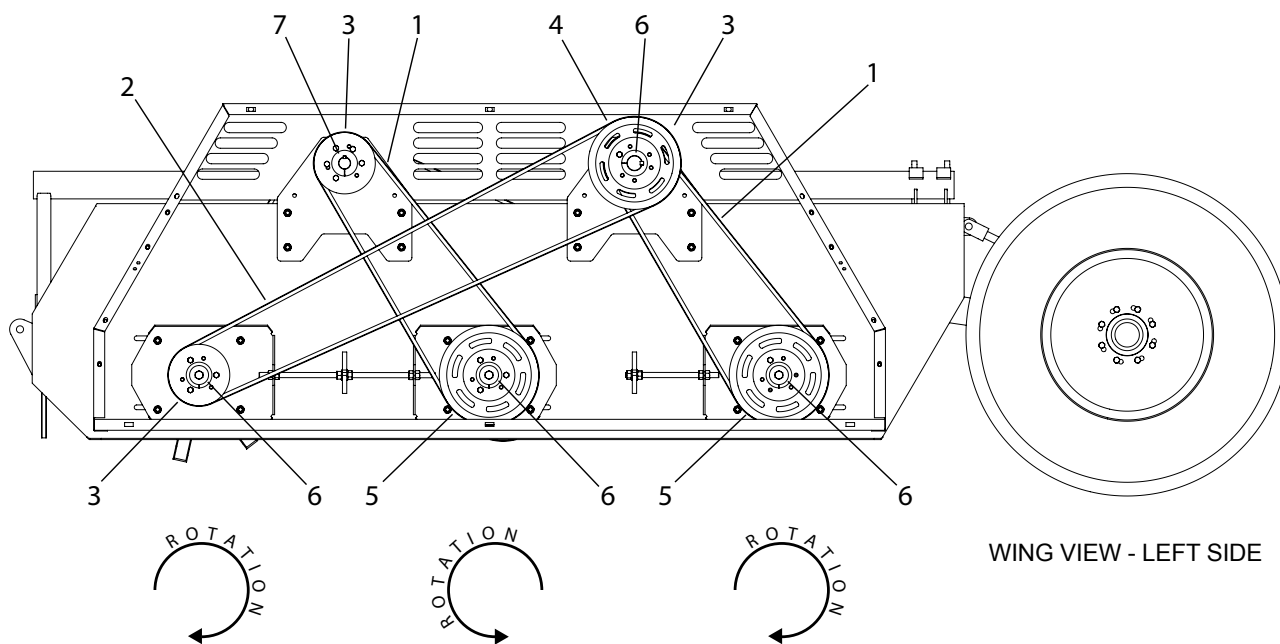
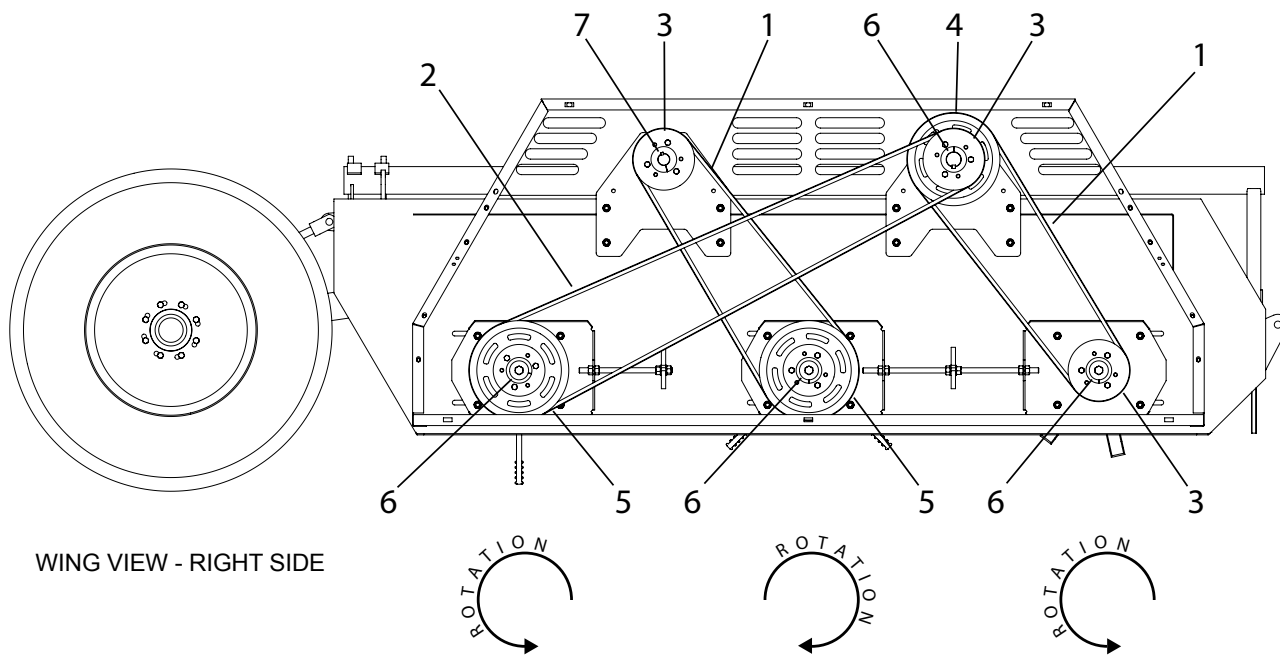
ITEM NO.	PART NUMBER	DESCRIPTION	QTY.
6	903-08420	QD BUSHING, 2-3/16 (TYPE E)	3
7	500-3-1550	OUTER STUB SHAFT	3
8	500-3-1060	HUB, 2"	3
9	500-3-2367	INSIDE STUB SHAFT	3
10	500-3-2373	PLASTIC SHIELD	3
11	500-3-2382	HANGER BEARING MOUNT	3
12	901-01408	PILOTED BEARING, 1-15/16	3
13	500-3-1636	FLAP ROD - 12R22	1
	500-3-2636	FLAP ROD - 12R20/8R30	
14	505-3-0868	FLAP SHIELD, 3-1/2"	-
15	505-3-1097	FLAP SHIELD, 6"	-
16	505-3-1089	FLAP SHIELD, 12"	-
17	500-3-1546	SMALL OUTPUT SHAFT - 12R22	1
	500-3-2638	SMALL OUTPUT SHAFT - 12R20/8R30	
18	500-3-1544	LARGE OUTPUT SHAFT - 12R22	1
	500-3-2643	LARGE OUTPUT SHAFT - 12R20/8R30	
19	500-3-1681	SMALL OUTPUT SHAFT SHIELD - 12R22	1
	500-3-2639	SMALL OUTPUT SHAFT SHIELD - 12R20/8R30	
20	500-3-1627	LARGE OUTPUT SHAFT SHIELD - 12R22	1
	500-3-2637	LARGE OUTPUT SHAFT SHIELD - 12R20/8R30	
21	901-01272	PILLOW BLOCK BEARING, 1-3/4"	2
22	500-3-1686	BEARING SHIELD MOUNT	2
23	500-3-1685	RUBBER HINGE	2
24	500-3-1682	BEARING SHIELD (RH)	2
	500-3-1683	BEARING SHIELD (LH)	-
25	901-01415	BEARING, 4 HOLE FLANGED, 1-3/4	
26	901-01416	BEARING, 4 HOLE FLANGED, 2-3/16	
27	500-2-1369	HANDLE	
28	500-2-1339	ROTOR BEARING CAP	
31	500-3-2803	SMALL OUTPUT SHAFT MOUNT	1
32	500-3-2802	LARGE OUTPUT SHAFT MOUNT	1
33	500-2-0671	SLIDE STRAP	6
34	500-2-0672	BEARING SLIDE	2
35	500-3-1629	ADJUSTMENT ROD (SHORT)	1
36	500-3-1628	ADJUSTMENT ROD (LONG)	1
37	500-3-2488	STEEL SPACER (2.91 LONG)	3
38	901-01311	BEARING, 4 HOLE FLANGED, 2-3/16"	3
39	500-3-1540	STEEL SPACER (4.16 LONG)	3
40	500-3-1463	WASHER	3
41	500-3-1058	QD BUSHING, 1-3/4" (TYPE E)	1
42	903-08420	QD BUSHING, 2-3/16" (TYPE E)	5
43	903-08362	PULLEY, 3C 8.5"	3
44	903-08363	PULLEY, 3C 13"	1
45	903-08421	PULLEY, 3C 14"	2
46	903-01433	BELT, 3C 105"	2
47	903-01434	BELT, 3C 173"	1
48	500-3-1734	FLAIL TUBE WELD-ON CLIP	60

## WING COVER COMPONENTS



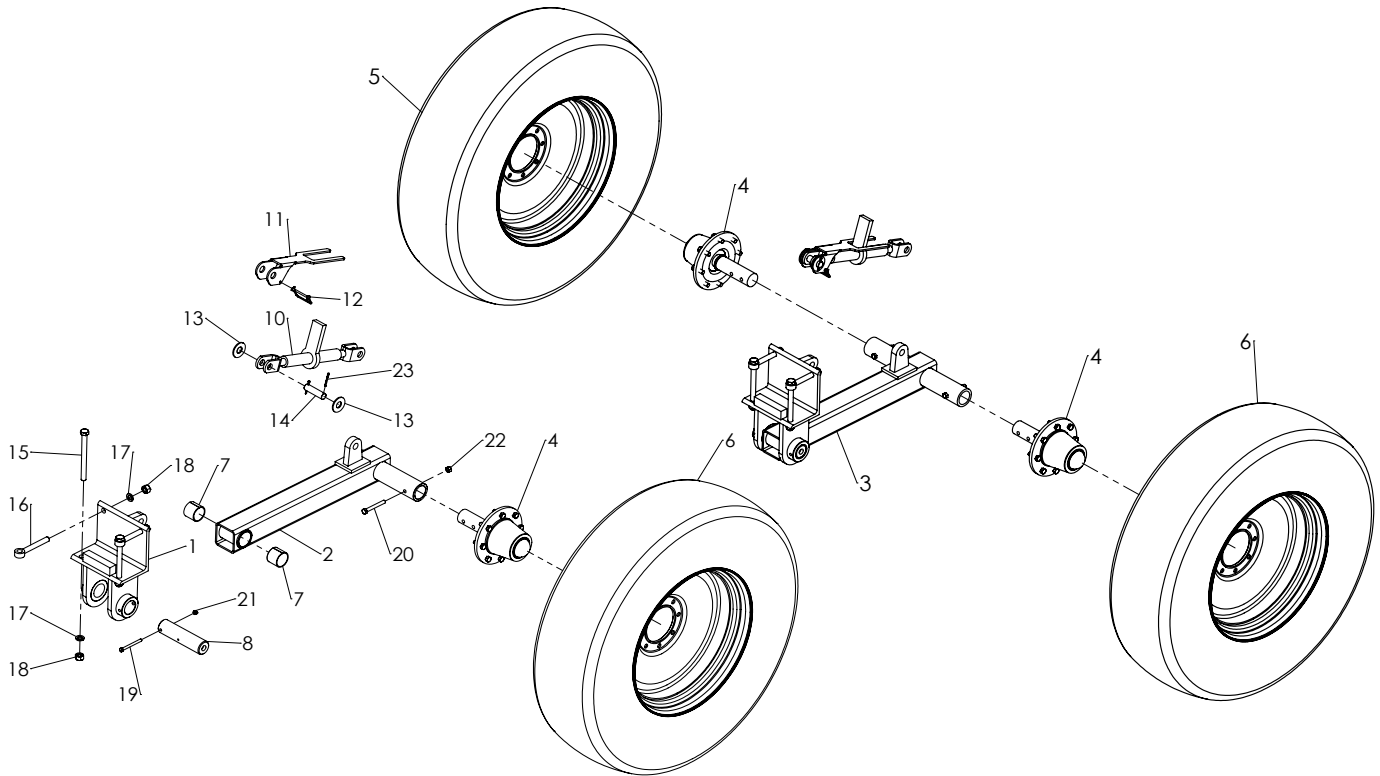
ITEM NO.	PART NUMBER	DESCRIPTION	QTY.
1	500-3-1535	RUBBER TOP, INSIDE	1
2	500-3-1536	RUBBER TOP, MIDDLE	1
3	500-3-1537	RUBBER TOP, OUTSIDE (12R22)	1
	500-3-2644	RUBBER TOP, OUTSIDE (12R20/8R30)	
4	500-3-1612	PLASTIC LINER, FRONT PANEL	1
5	500-3-1613	PLASTIC LINER, MIDDLE PANEL	1
6	500-3-1514	PLASTIC LINER, REAR PANEL	1
7	500-3-1466	TOP COVER STRIP (12R22)	1
	500-3-2641	TOP COVER STRIP (12R20/8R30)	
8	500-3-2653	TOP COVER STRIP RH - SHORT (12R22)	1
	500-3-2654	TOP COVER STRIP LH - SHORT (12R22)	
9	500-3-1533	CANVAS CLAMP STRIP	3
10	500-3-1467	REAR TOP TIE (12R22)	1
	500-3-2878	REAR TOP TIE (12R20/8R30)	
11	900-01695	BOLT, CARRIAGE 3/8 X 1, GR5 ZP	-
12	900-06139	NUT, SPIRALOCK FLANGE 3/8, GR8	-
13	900-16964	SCREW, SELF-DRILLING TEK 1/2 X 1-1/2	-
14	900-01229	BOLT, HEX HEAD 1/2 X 2, GR5 ZP	4
15	900-11035	WASHER, FLAT, 1/2	4
16	900-06143	NUT, SPIRALOCK FLANGE 1/2, GR8	4
17	900-21489	RIVET, POP 3/16 (.550)	44

## BELT ASSEMBLY COMPONENTS



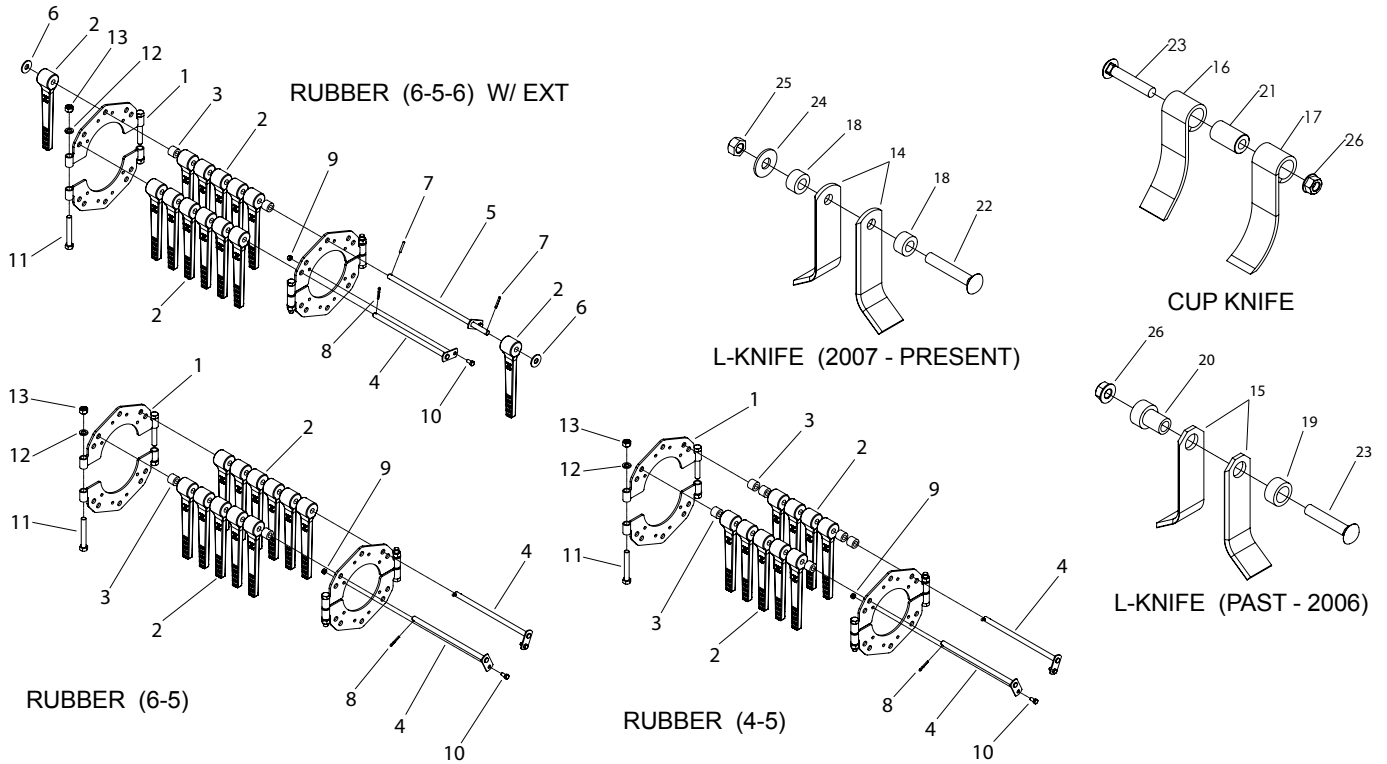
ITEM NO.	PART NUMBER	DESCRIPTION	QTY.
1	903-01433	BELT, 3C105, HY-T TORQUE TEAM	2
2	903-01434	BELT, XC175, HY-T TORQUE TEAM	1
3	903-08362	SHEAVE, QD, 3C8.5-E	3
4	903-08363	SHEAVE, QD, 3C13.0-E	1
5	903-08421	SHEAVE, QD, 3C14.0-E	1
6	903-08420	BUSHING, QD, 2-3/16, TYPE E	5
7	500-3-1058	BUSHING, QD, 1-3/4, TYPE E	1

## WING STRUT COMPONENTS



ITEM NO.	PART NUMBER	DESCRIPTION	QTY.
1	500-2-0686	MOUNTING ANGLE	1
2	500-2-0763	WING STRUT (SINGLE TIRE)	
3	500-2-1121	WING STRUT (DUAL TIRE)	
4	700-2-0165	HUB & SPINDLE ASSEMBLY	1 - 2
5	700-2-0168	TIRE & RIM ASSY (RH)	1
	905-09130	TIRE, 12.4-24	-
	905-09127	RIM, 24 x 10	-
6	700-2-0167	TIRE & RIM ASSY (LH)	1
	905-09130	TIRE, 12.4-24	-
	905-09127	RIM, 24 x 10	-
7	901-01318	BUSHING	2
8	500-3-2257	STRUT PIN	1
9	905-15024	STRAIGHT ZERK, 1/4-28	1
10	905-23014	RATCHET JACK	1
11	500-3-2202	RATCHET JACK LOCK	1
12	900-42065	SNAP PIN	1
13	900-11040	FLAT WASHER, 1"	2
14	500-3-2203	RATCHET JACK PIN	1
15	900-01437	BOLT, 3/4 NC x 8-1/2	2
16	900-03463	EYE BOLT, 3/4 NC x 6	2
17	900-11017	WASHER LOCK, 3/4	4
18	900-06015	NUT, 3/4 NC	4
19	900-01133	BOLT, 3/8 NC X 4	1
20	900-01245	BOLT, 1/2 NC X 4	-
21	900-06500	TOPLOCK NUT, 3/8 NC	1
22	900-06504	TOPLOCK NUT, 1/2 NC	-
23	900-23045	PIN, COTTER, 3/16 X 2	2

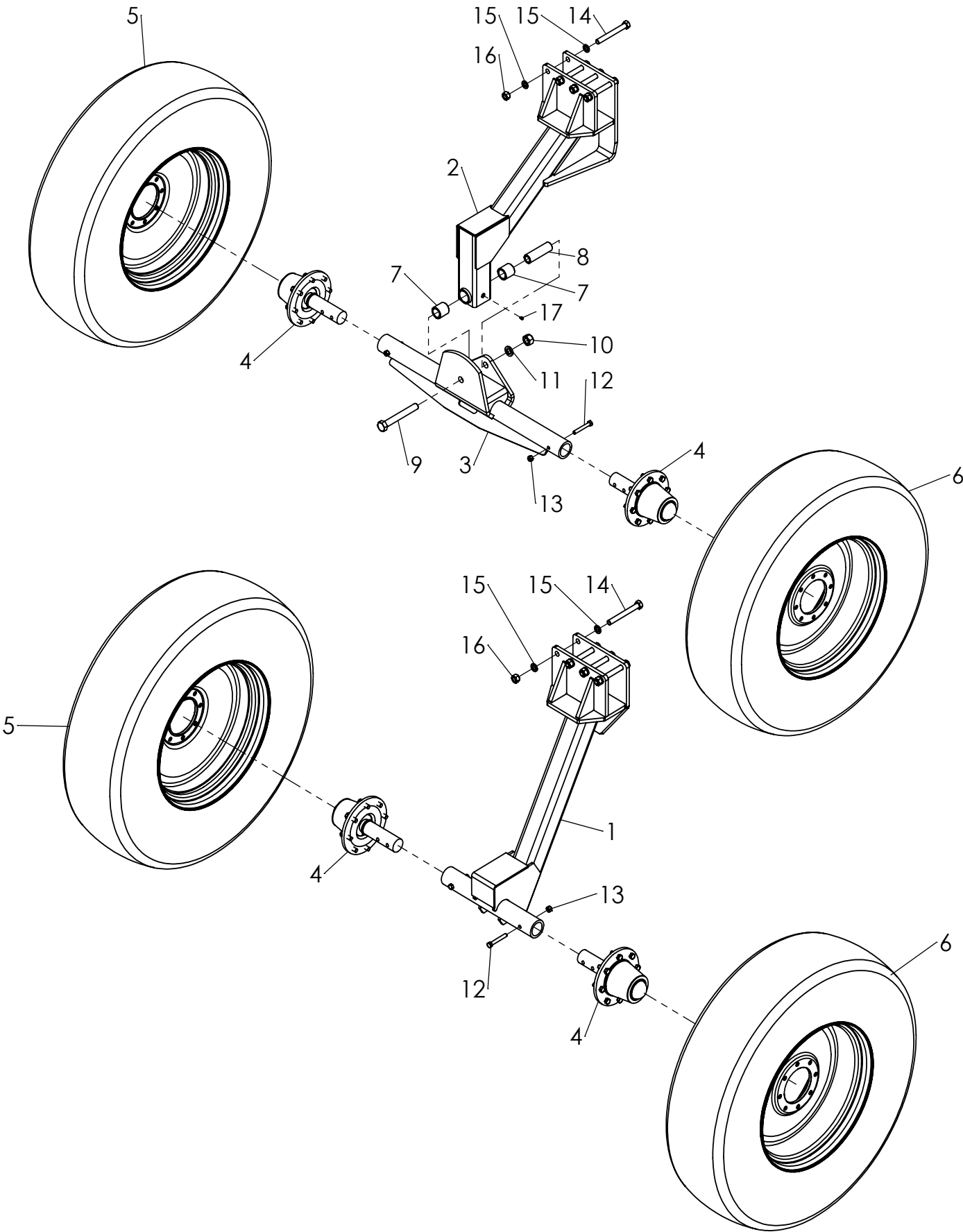
# FLAIL COMPONENTS



ITEM NO.	PART NUMBER	DESCRIPTION	QTY.
1	500-2-0067	FAIL MTG BRACKET WELD HALF	-
2	500-3-2578	RUBBER FLAIL (NAUFSINGER)	(2012 - PRESENT)
	500-3-0316	RUBBER FLAIL	(PAST - 2012)
3	500-3-0151	SPACER, 1", RUBBER FLAIL	-
4	500-2-0068	PIN WELD, RUBBER FLAIL	-
5	500-2-0069	PIN WELD, EXTENTION, RUBBER FLAIL	-
6	900-11131	WASHER, NYLON 5/8	-
7	900-29153	PIN, ROLL 7/32 X 1-1/2	-
8	900-23041	PIN, COTTER 3/16 X 1	-
9	900-06500	NUT, LOCK 3/8 NC	-
10	900-01105	BOLT, HEX HEAD 3/8 NC X 3/4, GR5 ZP	-
11	900-01363	BOLT, HEX HEAD 5/8 NC X 4-1/2, GR5 ZP	-
12	900-11015	WASHER, LOCK 5/8	-
13	900-06013	NUT, HEX HEAD 5/8 NC	-
14	505-3-0001	L-KNIFE (SMALL HOLE)	-
15	500-3-1735	L-KNIFE (LARGE HOLE)	-
16	505-3-0004	STEEL CUP KNIFE, SHORT 7"	(2008 - PRESENT)
17	505-3-0972	STEEL CUP KNIFE, SHORT 6-3/16"	(PAST - 2007)
18	500-3-2134	SPACER, SMALL HOLE	-
19	500-3-1736	SPACER, LARGE HOLE	-
20	500-3-1733	BUSHING	-
21	505-3-0405	BUSHING, WEAR	-
22	900-03064	BOLT, CARRIAGE 5/8 NC X 3-3/4, GR8 ZP (PARTIAL THREAD)	-
23	900-01792	BOLT, CARRIAGE 5/8 NC X 3-1/2, GR5 ZP (PARTIAL THREAD)	-
24	900-11037	WASHER, FLAT 5/8	-
25	900-06508	NUT, TOP LOCK 5/8 NC, GR8	-
26	900-06145	NUT, SPIRALOCK FLANGE 5/8 NC, GR8	-



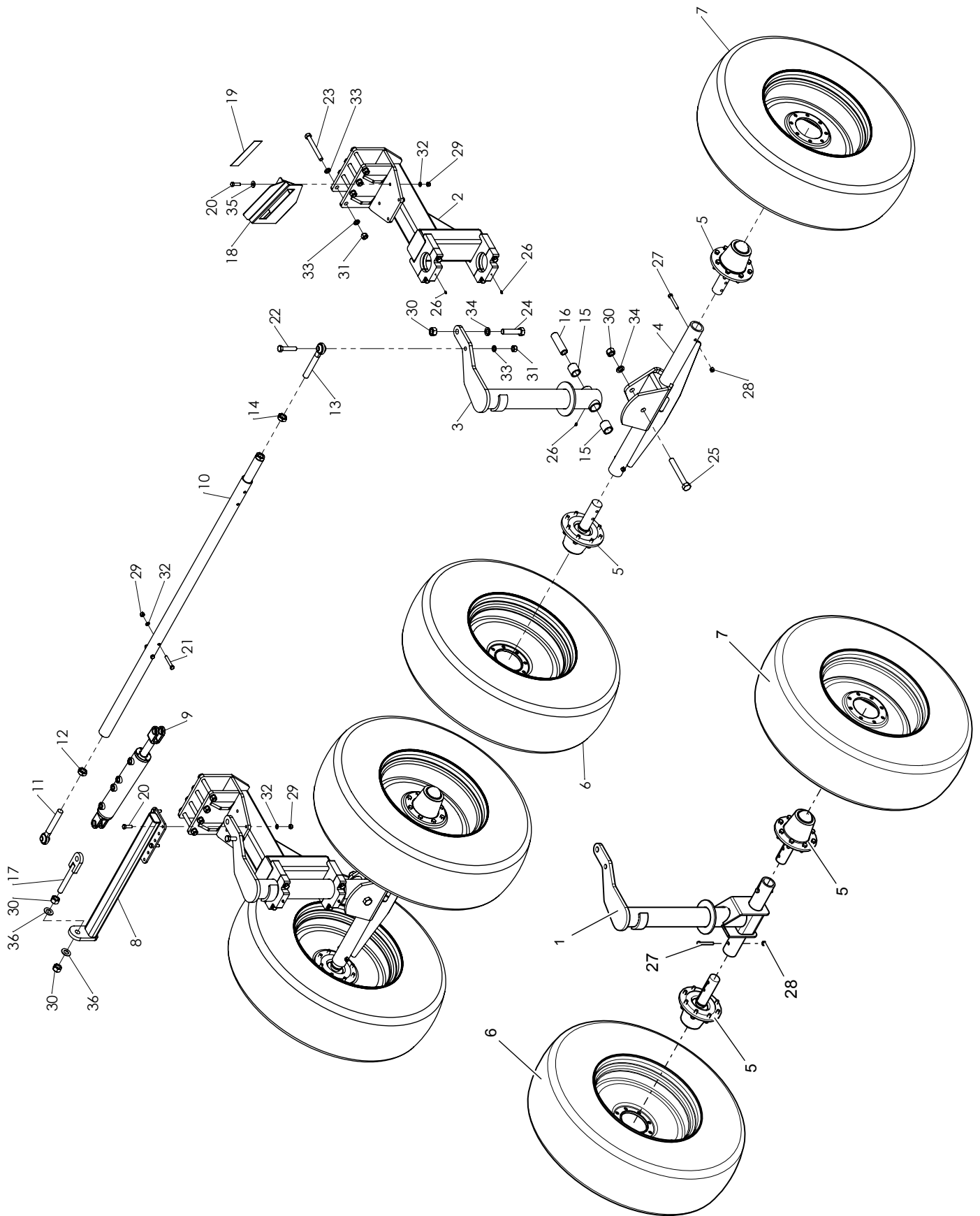
**FIXED STRUT COMPONENTS**



## FIXED STRUT COMPONENTS

ITEM NO.	PART NUMBER	DESCRIPTION	QTY.
1	500-2-0657	CENTER STRUT (22")	1
2	500-2-1167	UPPER PIVOT CENTER STRUT	1
3	500-2-1042	SPINDLE HOLDER (30")	1
	500-2-1274	SPINDLE HOLDER (40")	
	500-2-1151	SPINDLE HOLDER (44")	
4	700-2-0165	HUB & SPINDLE ASSY	2
5	700-2-0167	TRACTION TIRE ASSY (LH)	1
	905-09130	- TIRE, 12.4 X 24	
	905-09127	- RIM, 24 x 10 x 8 BOLT	
6	700-2-0168	TRACTION TIRE ASSY (RH)	1
	905-09130	- TIRE, 12.4 X 24	
	905-09127	- RIM, 24 x 10 x 8 BOLT	
7	500-3-1151	PIVOT BUSHING (BRONZE)	2
8	500-3-2236	PIVOT BUSHING (STEEL)	1
9	900-01541	BOLT, 1 NC x 7-1/2	1
10	900-06019	NUT, 1 NC	1
11	900-11021	LOCK WASHER, 1"	1
12	900-01241	BOLT, 1/2 NC x 3-1/2	2
13	900-06504	TOPLOCK NUT, 1/2 NC	2
14	900-01429	BOLT, 3/4 NC X 6-1/2	4
15	900-11017	LOCK WASHER, 3/4"	8
16	900-06015	NUT, 3/4 NC	4
17	905-15024	STRAIGHT ZERK, 1/4-28	-

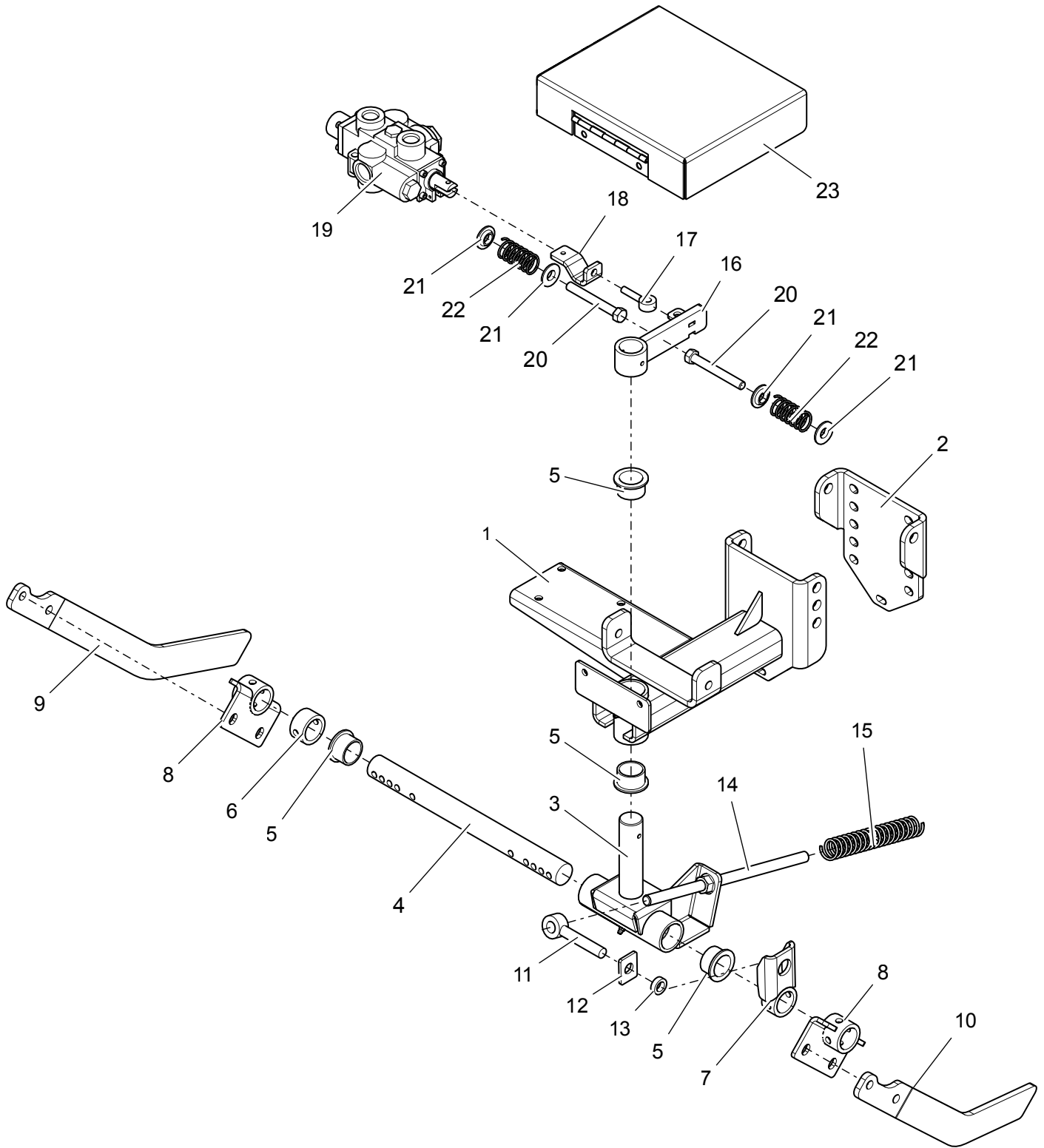
# STEERABLE STRUT COMPONENTS



## STEERABLE STRUT COMPONENTS

ITEM NO.	PART NUMBER	DESCRIPTION	QTY.
1	500-2-1240	CENTER STRUT 22"	2
2	500-2-1444	ADJUSTABLE REAR STEER WELD	2
3	500-2-1229	CENTER STRUT PIVOTING	2
4	500-2-1042	SPINDLE HOLDER (30")	2
	500-2-1274	SPINDLE HOLDER (40")	
	500-2-1151	SPINDLE HOLDER (44")	
5	700-2-0165	HUB & SPINDLE ASSY	4
6	700-2-0167	TRACTION TIRE ASSY (LH)	2
	905-09130	- TIRE, 12.4 X 24	
	905-09127	- RIM, 24 x 10 x 8 BOLT	
7	700-2-0168	TRACTION TIRE ASSY (RH)	2
	905-09130	- TIRE, 12.4 X 24	
	905-09127	- RIM, 24 x 10 x 8 BOLT	
8	500-2-1445		1
9	905-21452	DOUBLE CYLINDER	1
10	500-2-1205	ADJUSTMENT TUBE	1
11	903-05031	PIVOT LINK (RH)	-
12	900-06288	JAM NUT, 1" (RH)	-
13	903-05030	PIVOT LINK (LH)	-
14	900-06310	JAM NUT, 1" (LH)	-
15	500-3-1151	PIVOT BUSHING (BRONZE)	4
16	500-3-2236	PIVOT BUSHING (STEEL)	2
17	500-2-1446	ADJUSTABLE REAR STEER EYE BOLT	1
18	500-2-1484	STEERING GUAGE WELD	1
19	902-15117	DECAL, STEERING INDICATOR	1
20	900-01227	BOLT, 1/2 NC X 1-3/4	-
21	900-01237	BOLT, 1/2 NC X 3	-
22	900-01417	BOLT, 3/4 NC X 3-3/4	-
23	900-01429	BOLT, 3/4 NC X 6-1/2	-
24	900-01529	BOLT, 1 NC X 4-1/2	-
25	900-01541	BOLT, 1 NC X 7-1/2	-
26	905-15024	STRAIGHT ZERK, 1/4-28	-
27	900-01241	BOLT, 1/2 NC X 3-1/2	-
28	900-06504	TOPLOCK NUT, 1/2 NC	-
29	900-06009	NUT, 1/2 NC	-
30	900-06019	NUT, 1 NC	-
31	900-06015	NUT, 3/4 NC	-
32	900-11013	LOCK WASHER, 1/2"	-
33	900-11017	LOCK WASHER, 3/4"	-
34	900-11021	LOCK WASHER, 1"	-
35	900-11035	WASHER, 1/2"	-
36	905-09068	WASHER, 1" SAE	-

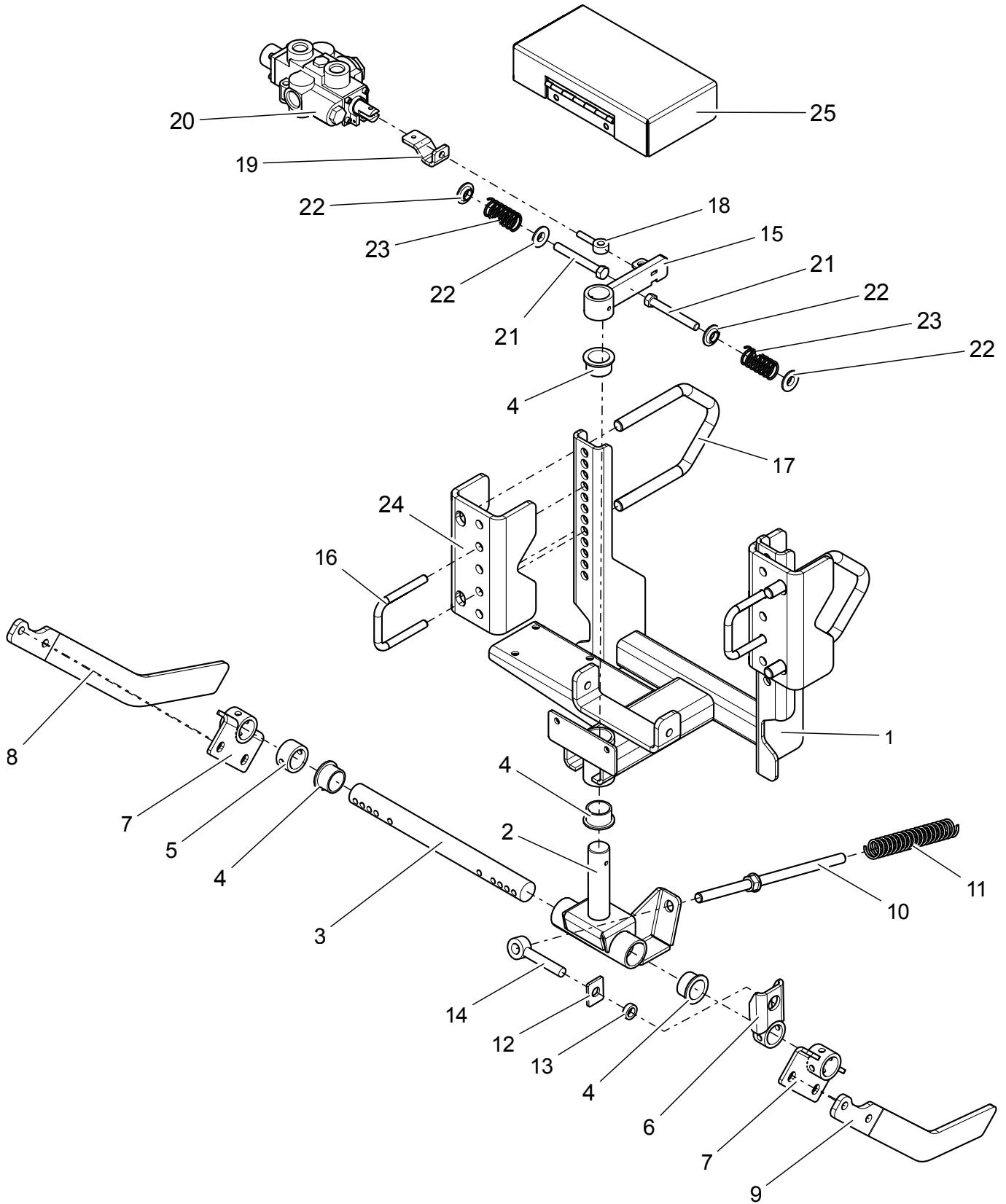
# ROW FINDER COMPONENTS



## ROW FINDER COMPONENTS

ITEM NO.	PART NUMBER	DESCRIPTION	QTY.
1	500-2-1249	PIVOT MOUNT	1
2	700-3-2186	INNER PIVOT MOUNT	1
3	700-2-0851	BOTTOM PIVOT	1
4	700-3-2170	PIVOT SHAFT	1
5	700-3-0383	BUSHING (OILITE)	4
6	700-3-2182	LOCK COLLAR	1
7	700-2-0853	SPRING TENSIONER	1
8	700-2-0854	FINGER MOUNT	2
9	700-3-2188	FINGER (LH)	1
10	700-3-2189	FINGER (RH)	1
11	900-03465	EYE BOLT	1
12	700-3-2187	INSIDE WASHER	1
13	700-3-2183	BUSHING (TENSIONER)	1
14	700-2-0856	TENSIONER ROD	1
15	905-14007	TENSIONER SPRING	1
16	700-2-0850	STEERING PADDLE	1
17	903-05044	ROD END EYE BOLT	1
18	700-3-2343	ADJUSTMENT PLATE	1
19	905-03262	CONTROL VALVE	1
20	900-01245	BOLT, 1/2 NC x 4	2
21	700-3-2185	SPRING RETAINER	4
22	905-14022	SPRING	2
23	500-2-1250	TOP COVER	1
-	500-2-1248	ROWFINDER COMPLETE ASSEMBLY	-

# TOOLBAR ROW FINDER COMPONENTS

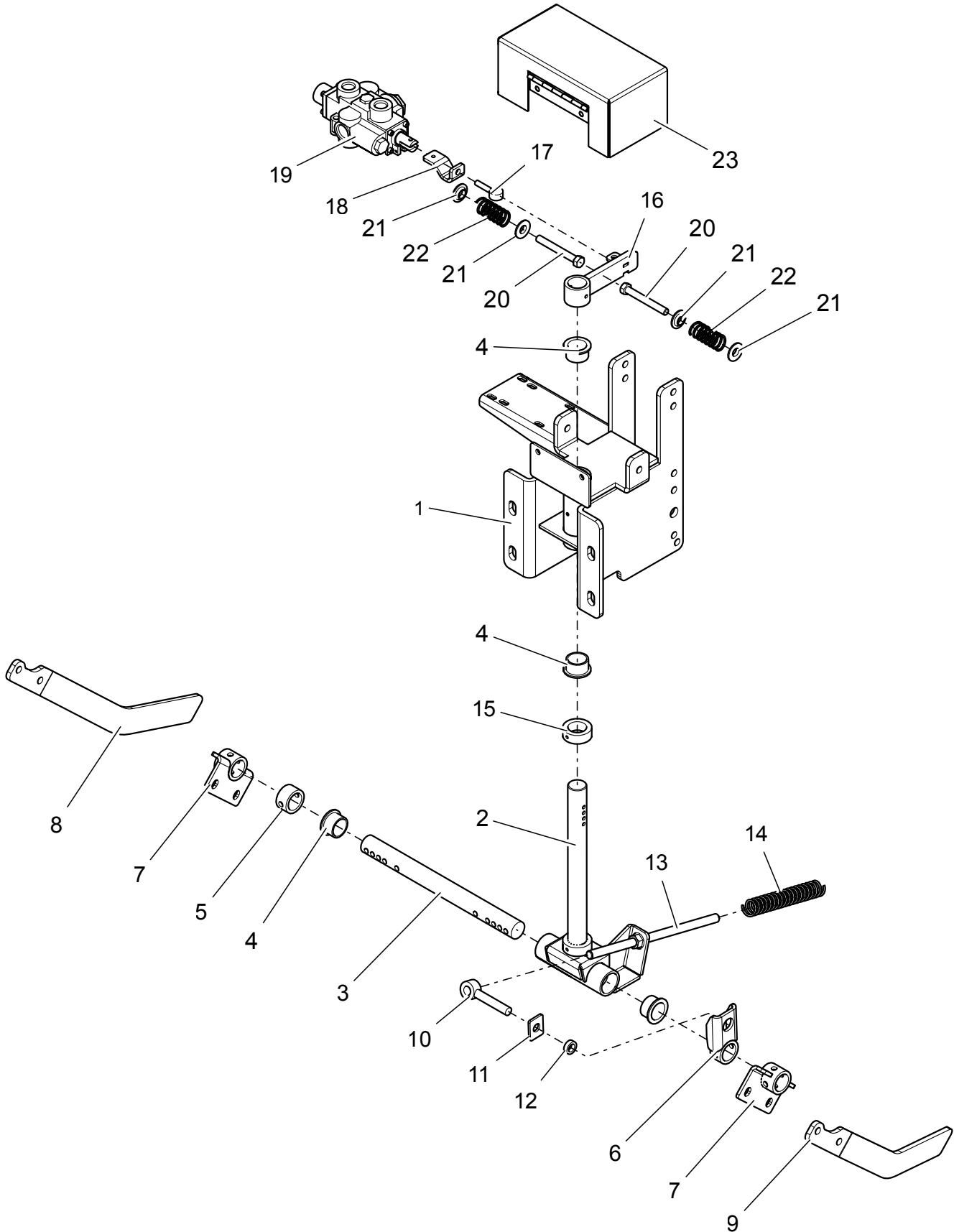


## TOOLBAR ROW FINDER COMPONENTS

ITEM NO.	PART NUMBER	DESCRIPTION	QTY.
1	500-2-1168	PIVOT MOUNT	1
2	700-2-0851	BOTTOM PIVOT	1
3	700-3-2170	PIVOT SHAFT	1
4	700-3-0383	BUSHING (OILITE)	4
5	700-3-2182	LOCK COLLAR	1
6	700-2-0853	SPRING TENSIONER	1
7	700-2-0854	FINGER MOUNT	2
8	700-3-2188	FINGER (LH)	1
9	700-3-2189	FINGER (RH)	1
10	700-2-0856	TENSIONER ROD	1
11	905-14007	TENSIONER SPRING	1
12	700-3-2187	INSIDE WASHER	1
13	700-3-2183	BUSHING (TENSIONER)	1
14	900-03465	EYE BOLT	1
15	700-2-0850	STEERING PADDLE	1
16	500-3-1578	U-BOLT, 1/2NC x 3 x 4	2
17	500-3-0635	A-BOLT, 3/4NC x 4 x 4	2
18	903-05044	ROD END EYE BOLT	1
19	700-3-2343	ADJUSTMENT PLATE	1
20	905-03262	CONTROL VALVE	1
21	900-01245	BOLT, 1/2 NC x 4	2
22	700-3-2185	SPRING RETAINER	4
23	905-14022	SPRING	2
24	500-3-2548	ADAPTER MOUNT	2
25	700-2-0908	TOP COVER	1
-	500-2-1169	ROWFINDER COMPLETE ASSEMBLY	-



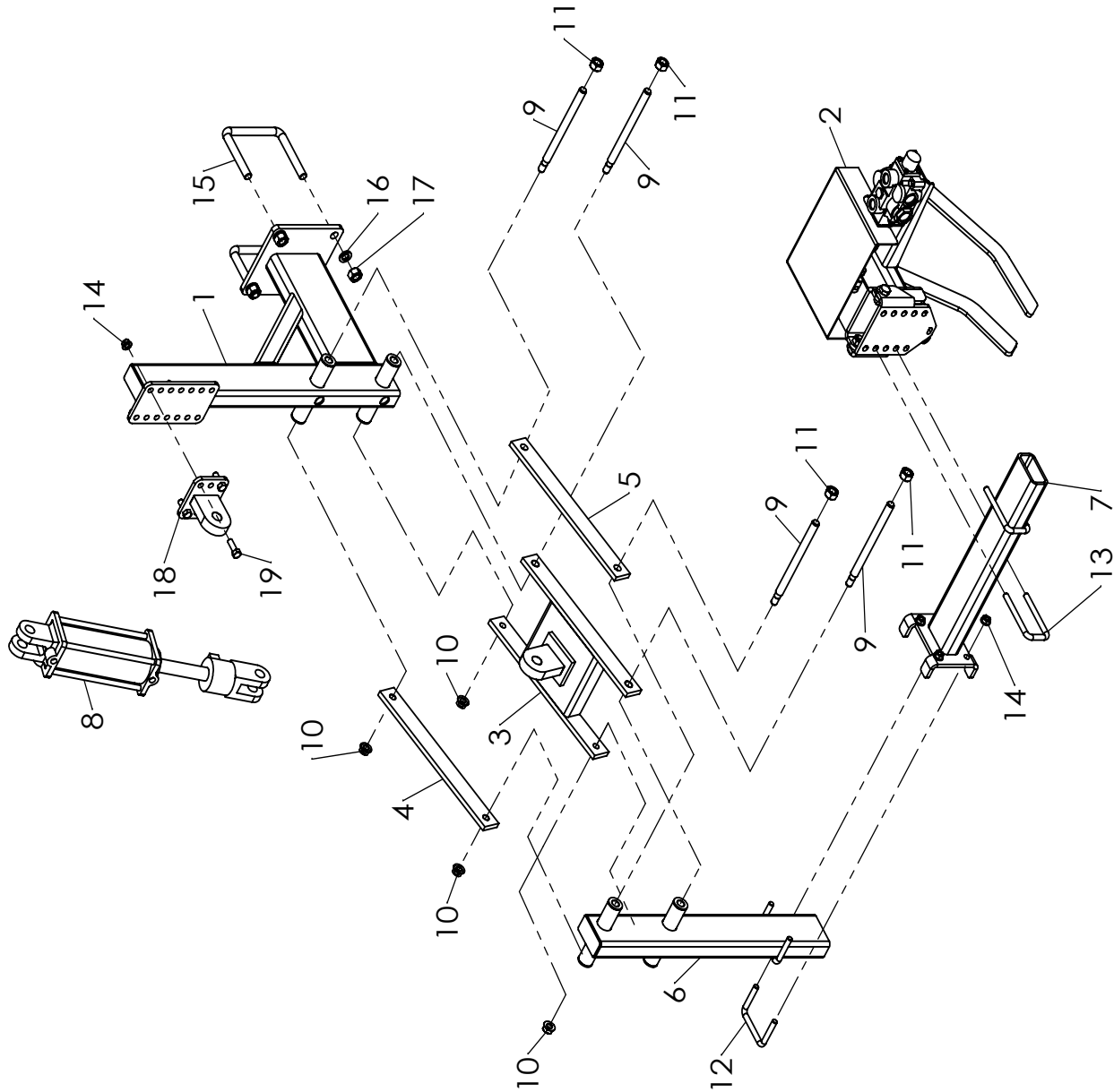
# CIRCULAR SCALPER ROW FINDER COMPONENTS



## CIRCULAR SCALPER ROW FINDER COMPONENTS

ITEM NO.	PART NUMBER	DESCRIPTION	QTY.
1	500-2-1259	PIVOT MOUNT	1
2	500-2-1258	BOTTOM PIVOT	1
3	700-3-2170	PIVOT SHAFT	1
4	700-3-0383	BUSHING (OILITE)	4
5	700-3-2182	LOCK COLLAR	1
6	700-2-0853	SPRING TENSIONER	1
7	700-2-0854	FINGER MOUNT	2
8	700-3-2188	FINGER (LH)	1
9	700-3-2189	FINGER (RH)	1
10	900-03465	EYE BOLT	1
11	700-3-2187	INSIDE WASHER	1
12	700-3-2183	BUSHING (TENSIONER)	1
13	700-2-0856	TENSIONER ROD	1
14	905-14007	TENSIONER SPRING	1
15	901-01323	LOCK COLLAR, 1-3/8"	1
16	700-2-0850	STEERING PADDLE	1
17	903-05044	ROD END EYE BOLT	1
18	700-3-2343	ADJUSTMENT PLATE	1
19	905-03262	CONTROL VALVE	1
20	900-01245	BOLT, 1/2 NC x 4	2
21	700-3-2185	SPRING RETAINER	4
22	905-14022	SPRING	2
23	500-2-1269	ROP COVER	1
-	500-2-1257	ROWFINDER COMPLETE ASSEMBLY	-

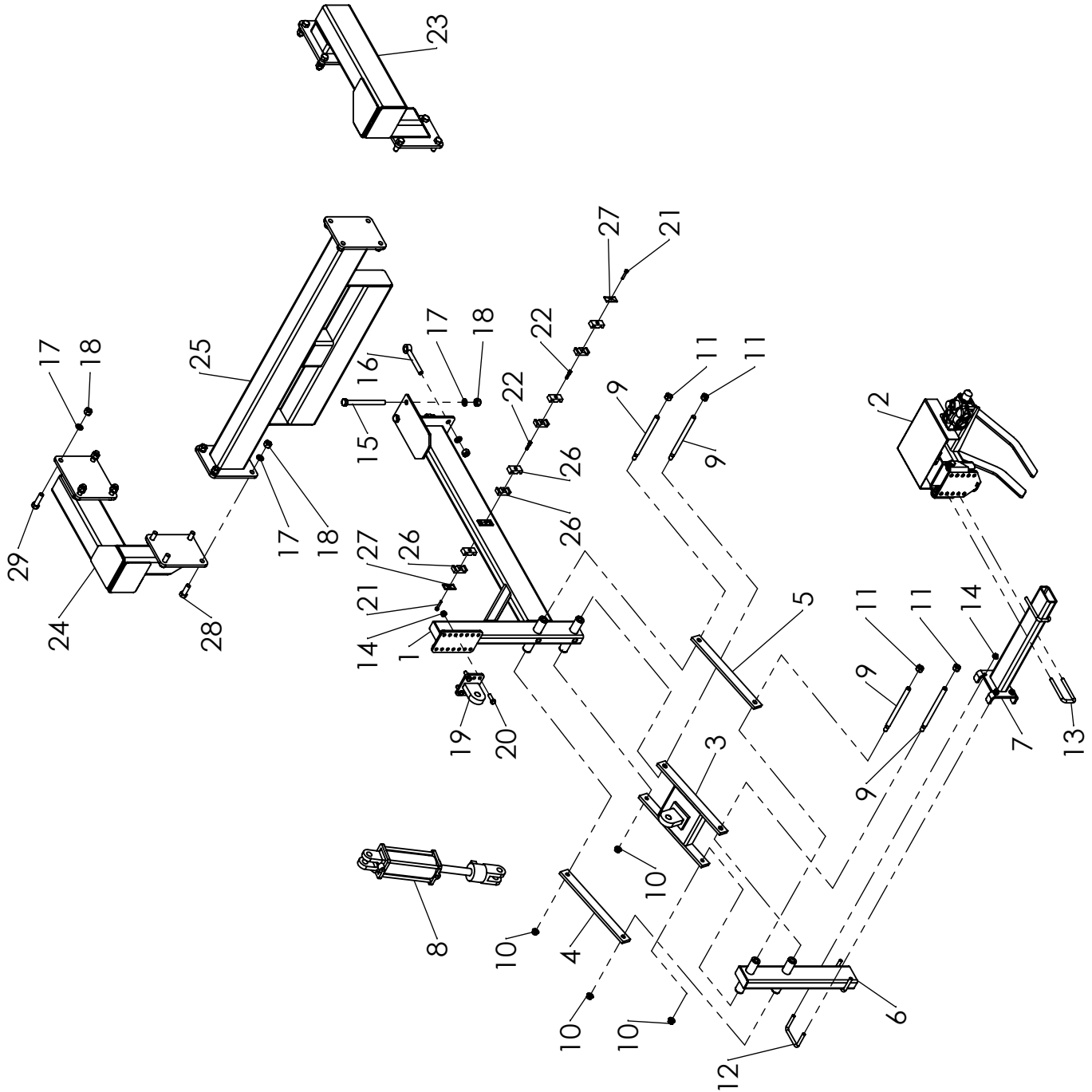
# ROWFINDER PARALLEL LINK MOUNT



## ROWFINDER PARALLEL LINK MOUNT

ITEM NO.	PART NUMBER	DESCRIPTION	QTY.
1	500-2-1080	UPPER MOUNT	1
2	500-2-1248	ROWFINDER	1
3	500-2-1081	H-ARM	1
4	500-3-0991	CONNECTING ARM (5/8" HOLES)	1
5	500-3-0992	CONNECTING ARM (3/4" HOLES)	1
6	500-2-1079	LOWER MOUNT	1
7	500-2-1029	HORIZONTAL MOUNT	1
8	905-21400	CYLINDER, 3-1/2 x 8	1
	905-21380	- SEAL KIT ( <b>PRINCE CYLINDERS ONLY</b> )	
	905-21401	- SEAL KIT ( <b>MONARCK CYLINDERS ONLY</b> )	
9	200-3-2631	PARALLEL LINK PIN	4
10	900-06145	SPIRALOCK NUT, 5/8 NC	4
11	900-06510	TOP LOCK NUT, 3/4 NC	4
12	200-3-1445	U-BOLT, 1/2 NC x 4 x 3	2
13	200-3-1447	U-BOLT, 1/2 NC x 2 x 5-1/4	2
14	900-06143	SPIRALOCK NUT, 1/2 NC	12
15	200-3-0024	U-BOLT, 3/4 NC x 6 x 5-1/2	2
16	900-11017	LOCK WASHER, 3/4	4
17	900-06015	NUT, 3/4 NC	4
18	500-2-1474	ADJUSTABLE CYLINDER EAR WELD	1
19	900-01225	BOLT, 1/2 NC X 1-1/2	4
-	500-1-0182	ROW FINDER REAR TUBE MOUNT KIT	-

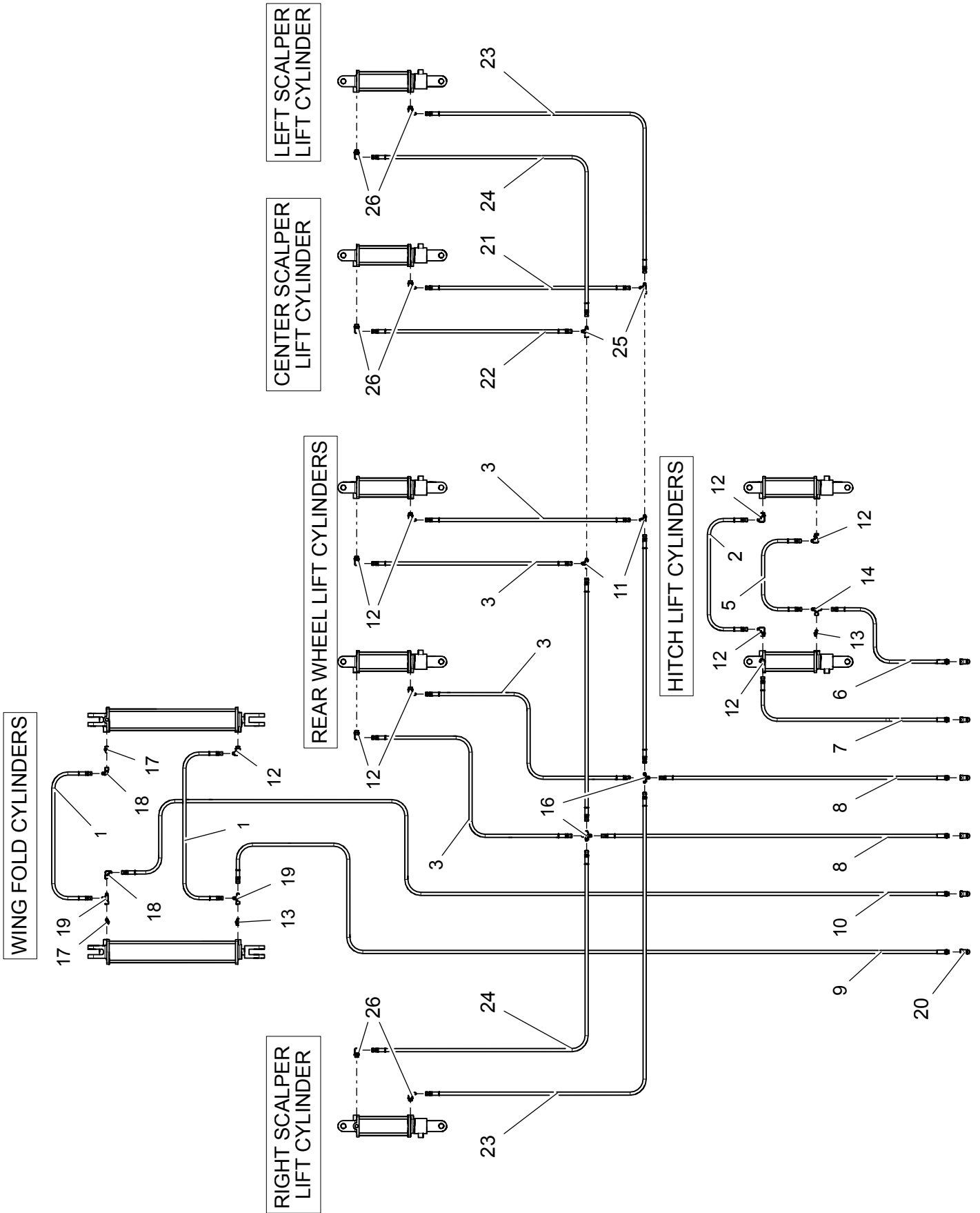
# ROWFINDER PARALLEL LINK MOUNT (44" STRUTS)



## ROWFINDER PARALLEL LINK MOUNT (44" STRUTS)

ITEM NO.	PART NUMBER	DESCRIPTION	QTY.
1	500-2-1254	UPPER MOUNT	1
2	500-2-1248	ROW FINDER	1
3	500-2-1081	H-ARM	1
4	500-3-0991	CONNECTING ARM (5/8" HOLES)	1
5	500-3-0992	CONNECTING ARM (3/4" HOLES)	1
6	500-2-1255	LOWER MOUNT	1
7	500-2-1029	HORIZONTAL MOUNT	1
8	905-21400	CYLINDER, 3-1/2" x 8	1
	905-21380	- SEAL KIT ( <b>PRINCE CYLINDERS ONLY</b> )	
	905-21401	- SEAL KIT ( <b>MONARCK CYLINDERS ONLY</b> )	
9	200-3-2631	PARALLEL LINK PIN	4
10	900-06145	SPIRALOCK NUT, 5/8 NC	4
11	900-06510	TOP LOCK NUT, 3/4 NC	4
12	200-3-1445	U-BOLT, 1/2 NC x 4 x 3	2
13	200-3-1447	U-BOLT, 1/2 NC x 2 x 5-1/4	2
14	900-06143	SPIRALOCK NUT, 1/2 NC	12
15	900-01437	BOLT, 3/4 NC x 8-1/2	2
16	900-03463	EYE BOLT, 3/4 NC x 6	2
17	900-11017	LOCK WASHER, 3/4	20
18	900-06015	NUT, 3/4 NC	20
19	500-2-1474	ADJUSTABLE CYLINDER EAR WELD	1
20	900-01225	BOLT, 1/2 NC X 1-1/2	4
21	900-02356	BOLT, 5/16 NC X 1-3/4	2
22	900-31071	BOLT, STACKING 5/16 UNC	2
23	500-2-1233	SCALPER SET BACK WELD - RH	1
24	500-2-1231	SCALPER SET BACK WELD - LH	1
25	500-2-1234	SCALPER CROSS TUBE WELD	1
26	900-31069	CLAMP BODY	8
27	900-31068	COVER PLATE AND BOLT	2
28	900-01403	BOLT, 3/4 NC X 2	8
29	900-01407	BOLT, 3/4 NC X 2-1/2	8
-	500-1-0366	ROW FINDER REAR TUBE MOUNT KIT (44" STRUTS)	-

# HYDRAULIC COMPONENTS



## HYDRAULIC COMPONENTS

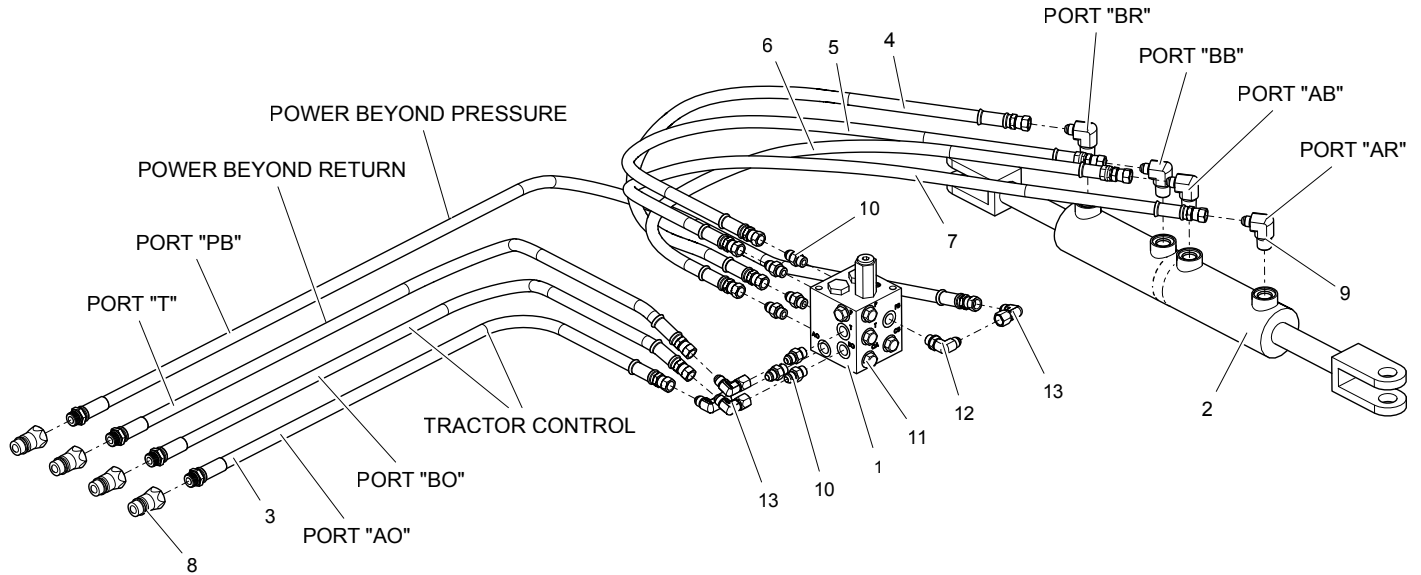
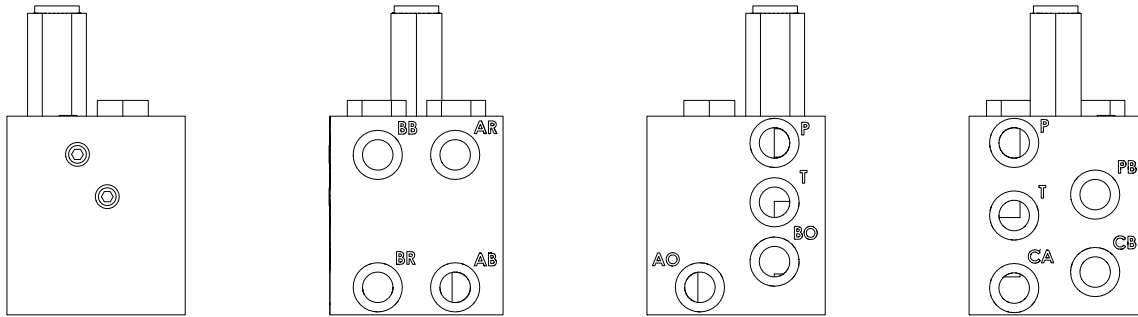
ITEM NO.	PART NUMBER	DESCRIPTION	QTY.	
1	905-19136	3/8 HOSE, 6FJX x 6FJX	41.50"	2
2	905-19141	3/8 HOSE, 6FJX x 6FJX	50.00"	1
3	905-19134	3/8 HOSE, 6FJX x 6FJX	53.50"	4
4	905-19135	3/8 HOSE, 6FJX x 6FJX	58.00"	2
5	905-19142	3/8 HOSE, 6FJX x 6FJX	70.00"	1
6	905-19140	3/8 HOSE, 6FJX x 8MB	138.00"	1
7	905-19139	3/8 HOSE, 6FJX x 8MB	150.00"	1
8	905-19133	3/8 HOSE, 6FJX x 8MB	252.00"	2
9	905-19127	3/8 HOSE, 6FJX x 8MB	300.00"	1
10	905-19138	3/8 HOSE, 6FJX x 8MB	324.00"	1
11	905-03112	ADAPTER, TEE, 6MJ		2
12	905-03114	ADAPTER, 90° ELBOW, 6MJ x 8MB		9
13	905-03115	ADAPTER, STRAIGHT, 6MJ x 8MB		2
14	905-03127	ADAPTER, TEE, 6MJ x 6MJ x 6FJX		1
15	905-03140	ADAPTER, CAP, 6FJ		4
16	905-03141	ADAPTER, CROSS, 6MJ		2
17	905-03162	ADAPTER, RESTRICTOR, 6MJ x 8MB (1/16 HOLE)		2
18	905-03163	ADAPTER, 90° ELBOW, 6MJ x 6FJX		2
19	905-03199	ADAPTER, TEE, 6FJX x 6MJ x 6MJ		2
20	905-19126	QUICK COUPLER, 8FB		6
-	500-2-0709	MAIN FRAME HYDRAULIC KIT <b>*DOES NOT INCLUDE CYLINDERS*</b>		-

## SCALPER HYDRAULIC COMPONENTS

ITEM NO.	PART NUMBER	DESCRIPTION	QTY.	
21	905-19193	3/8 HOSE, 6FJX x 6FJX	106.00"	1
22	905-19147	3/8 HOSE, 6FJX x 6FJX	111.00"	1
23	905-19155	3/8 HOSE, 6FJX x 6FJX	120.00"	2
24	905-19143	3/8 HOSE, 6FJX x 6FJX	130.00"	2
25	905-03199	ADAPTER, TEE, 6FJX x 6MJ x 6MJ		2
26	905-03114	ADAPTER, 90° ELBOW, 6MJ x 8MB		6
-	500-1-0265	SCALPER HYDRAULIC KIT <b>*DOES NOT INCLUDE CYLINDERS*</b>		-

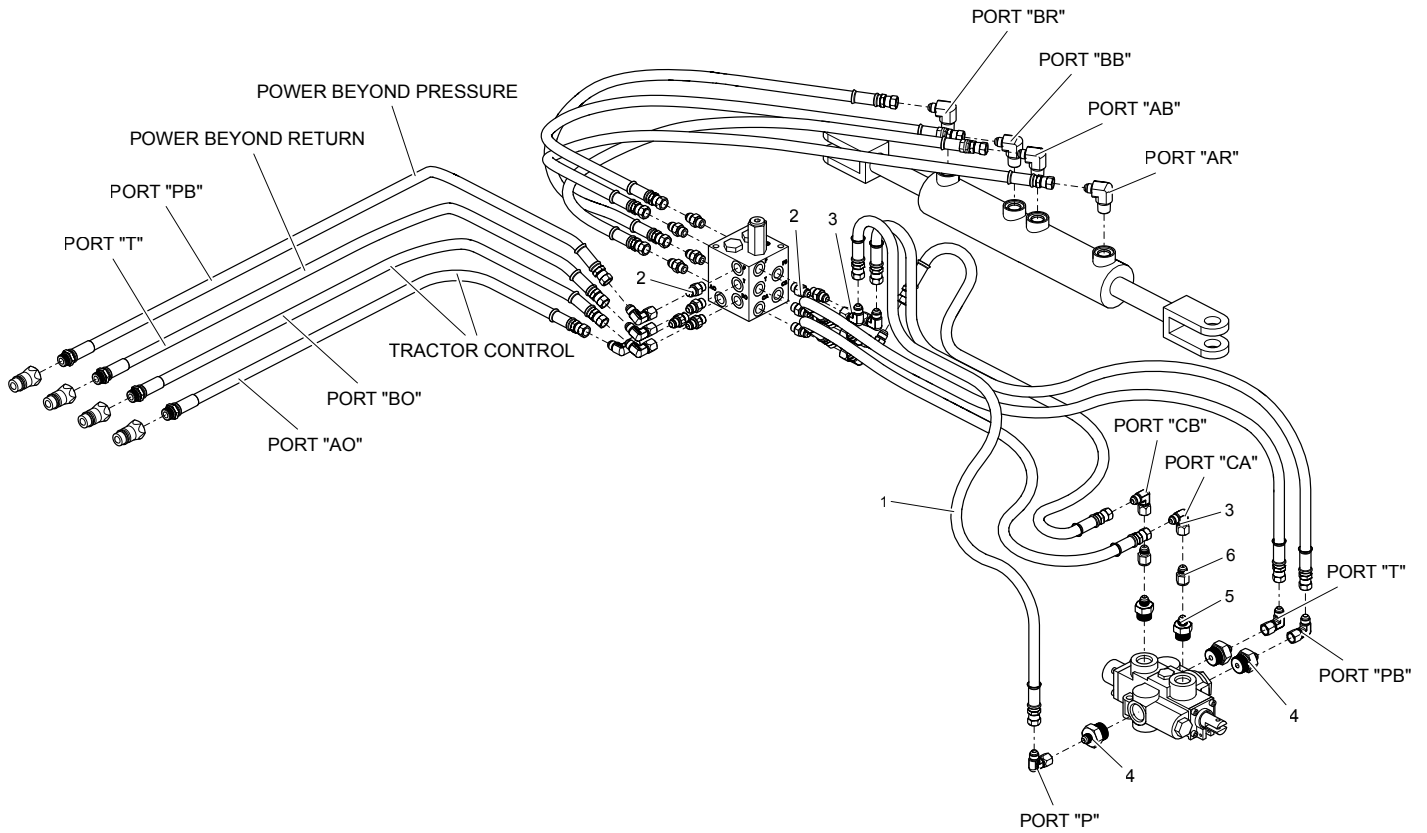


## REAR STEER HYDRAULIC COMPONENTS



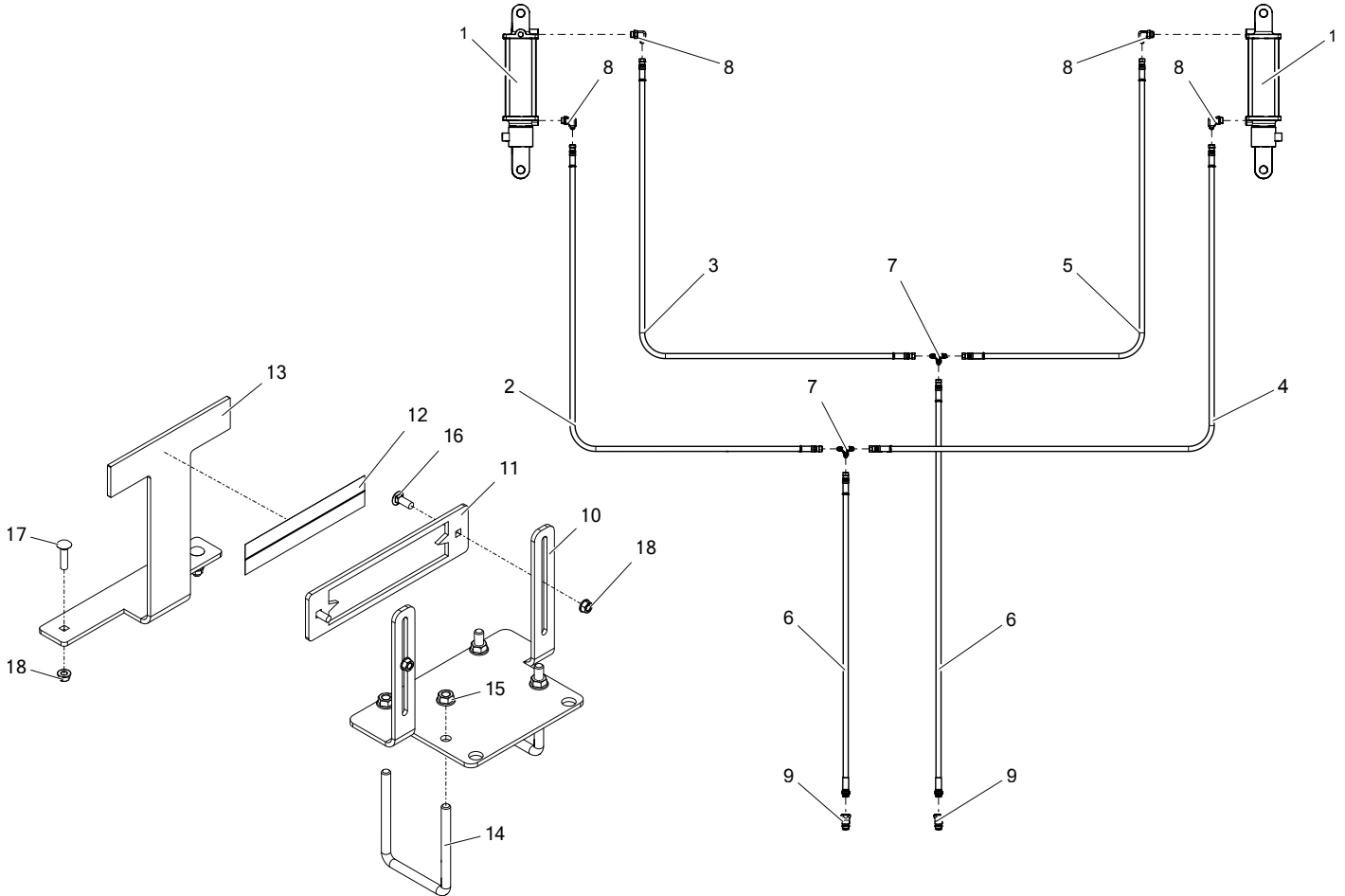
ITEM NO.	PART NUMBER	DESCRIPTION	QTY.
1	905-03263	MANIFOLD BLOCK	1
2	905-21452	DOUBLE CYLINDER	1
3	905-19213	3/8 HOSE, 8MB x 6FJX	4
4	905-19190	3/8 HOSE, 6FJX x 6FJX	1
5	905-19118	3/8 HOSE, 6FJX x 6FJX	1
6	905-19237	3/8 HOSE, 6FJX x 6FJX	1
7	905-19215	3/8 HOSE, 6FJX x 6FJX	1
8	905-19126	QUICK COUPLER, 8FB	4
9	905-03117	ADAPTER, 90° ELBOW, 6MJ x 8MP	4
10	905-03120	ADAPTER, STRAIGHT, 6MJ x 6MB	7
11	905-03265	ADAPTER, PLUG, 6MB	5
12	905-03264	ADAPTER, 90° ELBOW, 6MJ x 6MB	1
13	905-03163	ADAPTER, 90° ELBOW, 6MJ x 6FJX	4
-	500-1-0342	REAR STEER HOSE KIT *DOES NOT INCLUDE HYD CYLINDER*	-

# ROW FINDER HYDRAULIC COMPONENTS



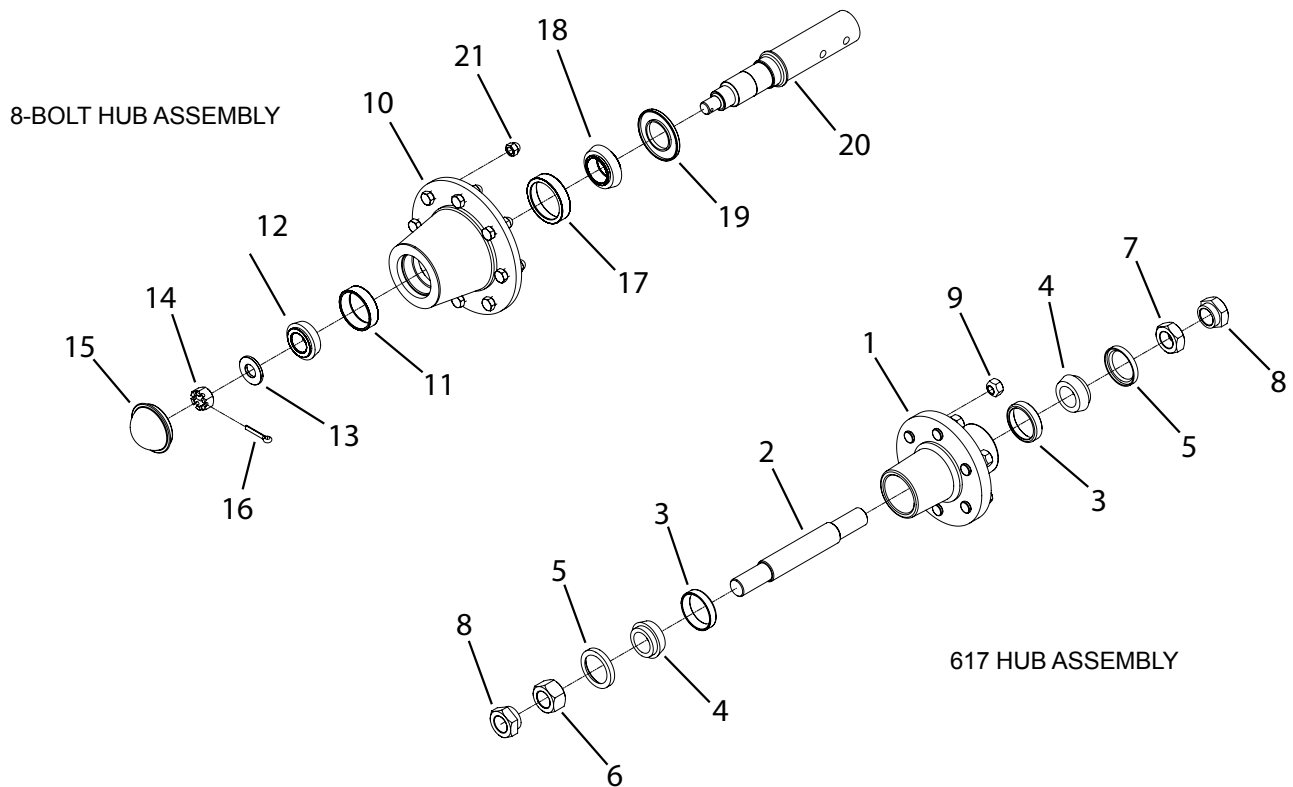
ITEM NO.	PART NUMBER	DESCRIPTION	QTY.	
1	905-19155	3/8 HOSE, 6FJ x 6FJ	120.00"	5
2	905-03120	ADAPTER, STRAIGHT, 6MJ x 6MB		6
3	905-03163	ADAPTER, 90° ELBOW, 6MJ x 6FJ		10
4	905-03210	ADAPTER, STRAIGHT, 6MJ x 12MB		3
5	905-03198	ADAPTER, STRAIGHT, 6MJ x 10MB		2
6	905-03220	ADAPTER, 1/16 RESTRICTOR, 6FJ x 6MJ		1
-	500-1-0343	ROW FINDER HOSE KIT		-

## WING LIFT HYDRAULIC COMPONENTS



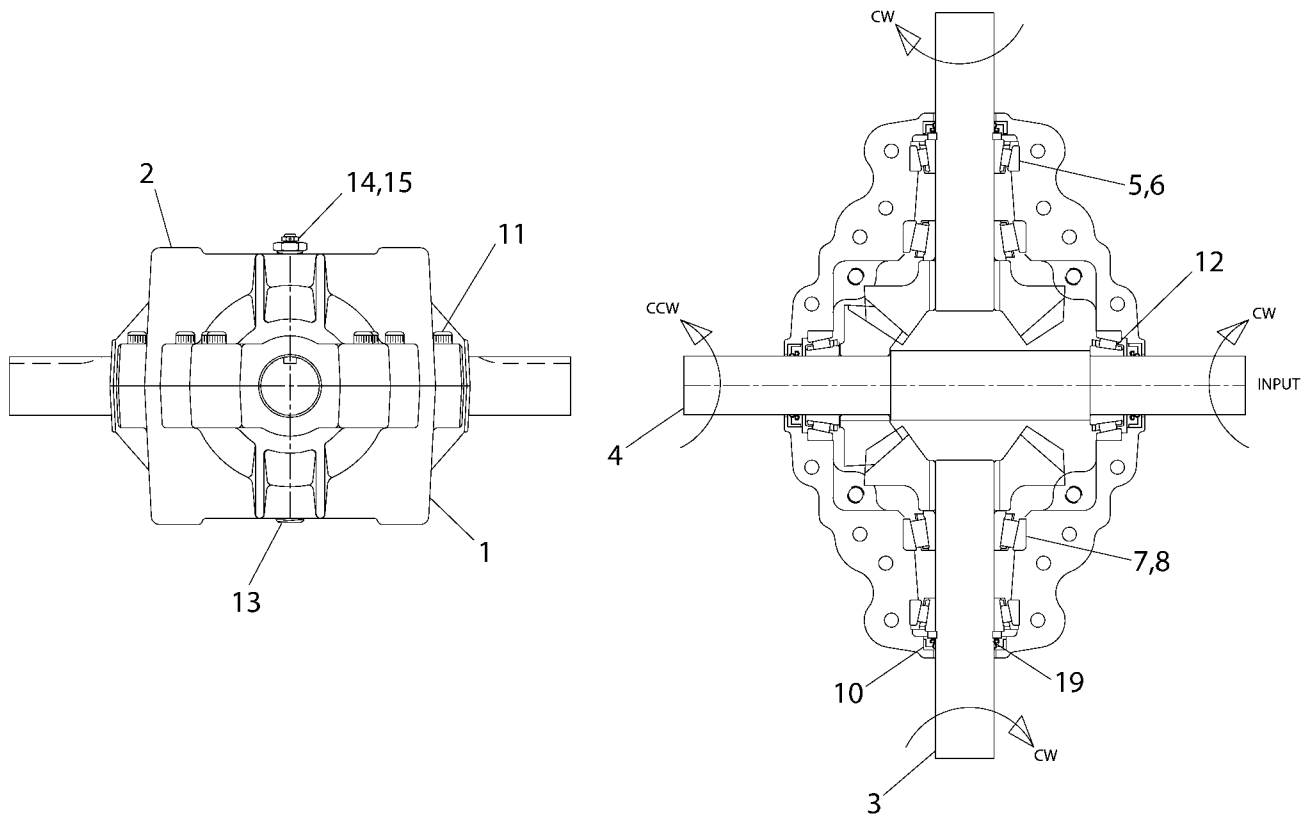
ITEM NO.	PART NUMBER	DESCRIPTION	QTY.
1	905-21400	CYLINDER, 3-1/2 x 8	2
2	905-19155	3/8 HOSE, 6FJX x 6FJX	120.00" 1
3	905-19143	3/8 HOSE, 6FJX x 6FJX	130.00" 1
4	905-19177	3/8 HOSE, 6FJX x 6FJX	183.00" 1
5	905-19171	3/8 HOSE, 6FJX x 6FJX	193.00" 1
6	905-19133	3/8 HOSE, 6FJX x 8MB	252.00" 2
7	905-03112	ADAPTER, TEE, 6MJ	2
8	905-03114	ADAPTER, 90° ELBOW, 6MJ x 8MB	4
9	905-19126	QUICK COUPLER, 8FB	2
10	500-3-1923	FRONT BRACKET	1
11	500-3-1922	POINTER	1
12	200-3-4034	DECAL, ORANGE	1
13	500-3-2877	FLAG BRACKET	1
14	100-3-2582	U-BOLT, 1/2 NC x 4 x 5-1/2	2
15	900-06143	NUT, SPIRALOCK, 1/2 NC	4
16	900-01695	BOLT, CARRIAGE, 3/8 NC x 1	2
17	900-01697	BOLT, CARRIAGE, 3/8 NC x 1-1/2	2
18	900-06139	NUT, SPIRALOCK, 3/8 NC	4
-	500-2-0866	WING LIFT HOSE KIT <b>*DOES NOT INCLUDE CYLINDERS*</b>	-
-	500-1-0112	WING LIFT KIT <b>*INCLUDES CYLINDERS*</b>	-

## HUB & SPINDLE ASSEMBLY COMPONENTS



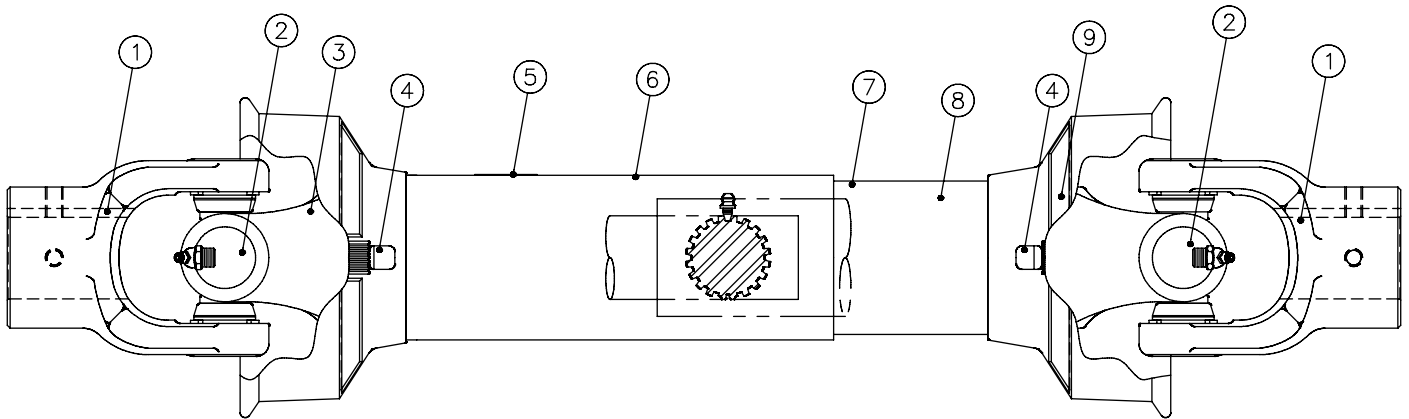
ITEM NO.	PART NUMBER	DESCRIPTION	QTY.
1	905-09082	HUB W/ CUPS (617)	1
2	2003-1240	FORK SPINDLE	1
3	901-01148	BEARING CUP	2
4	901-01149	BEARING CONE	2
5	901-09127	SEAL	2
6	900-06024	NUT, HEX HEAD 1-1/4 NF, ZP	1
7	900-06291	NUT, HEX HEAD, JAM 1-1/4 NF, ZP	1
8	200-3-1847	NUT, HEX HEAD, SHOULDER 1-1/4 NF	2
9	905-09134	NUT, HEX HEAD, WHEEL 9/16 NF	6
10	905-09136	HUB W/ CUPS (8-BOLT)	1
11	901-01324	BEARING CUP	1
12	901-01326	BEARING CONE	1
13	905-09067	WASHER, 7/8 SAE	1
14	900-06060	NUT, HEX HEAD, SLOTTED 7/8 NF	1
15	905-09135	HUB CAP	1
16	900-23064	PIN, COTTER 1/4 X 2	1
17	901-01152	BEARING CUP	1
18	901-01325	BEARING CONE	1
19	901-09215	SEAL	1
20	700-3-0143	SPINDLE	1
21	905-09011	NUT, HEX HEAD, WHEEL 1/2 NF	1

## GEARBOX - SUPERIOR (4-WAY)



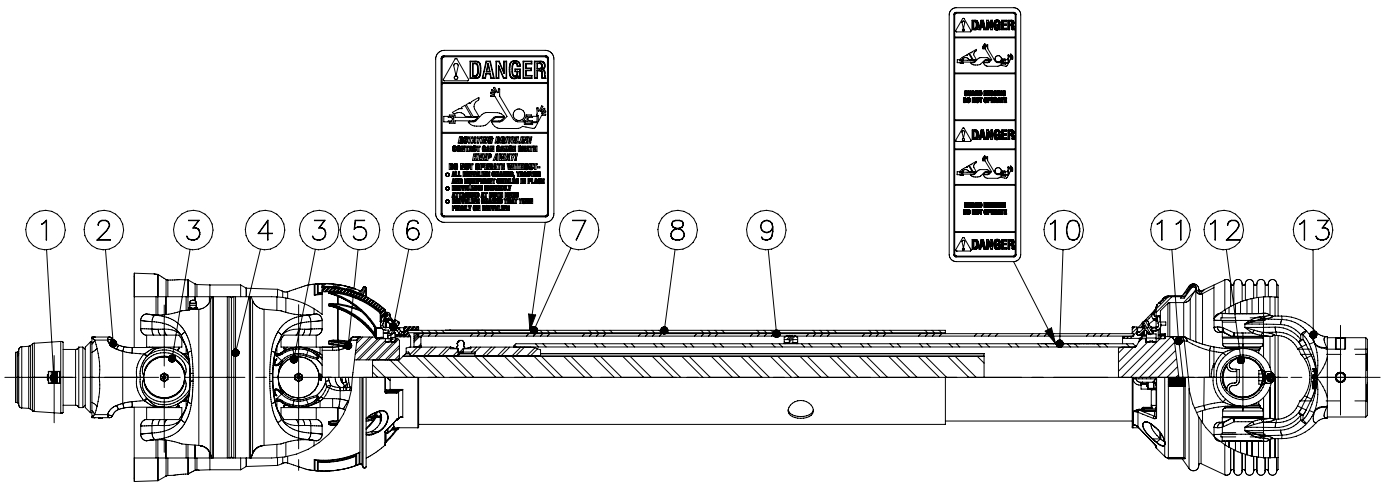
ITEM NO.	PART NUMBER	DESCRIPTION	QTY.
1	903-15526	CASTING, MACH 600	1
2	903-15525	CASTING, MACH 600	1
3	903-15561	ASSY, STUB SHAFT/GEAR R600	2
4	903-15562	ASSY, CROSS SHAFT/GEAR	1
5	901-01150	BEARING CONE 25581	3
6	901-01152	BEARING CUP 25520	4
7	901-01151	BEARING CONE 3782	2
8	901-01153	BEARING CUP 3720	2
9	900-39030	RETAINING RING, EXT 1.750 SHFT	2
10	901-09125	SEAL TC-1.750-2.437-.312	4
11	900-03033	BOLT, 3/8-16 X 2.25 SHCS	16
12	901-01328	BEARING CONE 25580	1
13	905-03078	PLUG, 1/2-14 NPTSCHDW/3M	1
14	905-03080	PLUG, VENT 5PSI	1
15	905-15359	BUSHING, 1/2 NPT TO 1/8 NPT	1
16	903-15560	GEARBOX, COMPLETE	1

## JUMP DRIVE SHAFT COMPONENTS



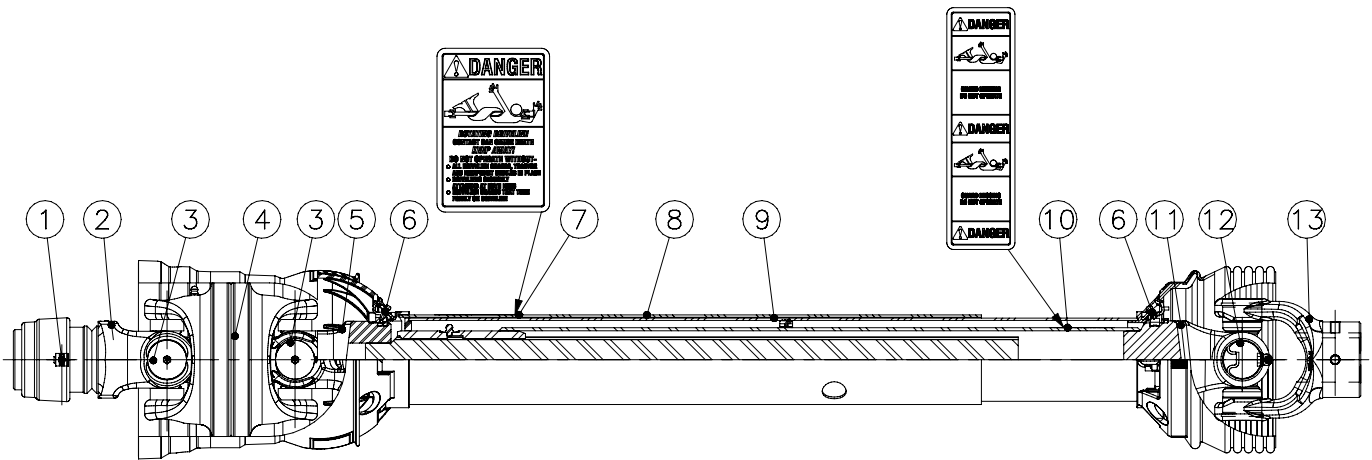
ITEM NO.	PART NUMBER	DESCRIPTION	QTY.
1	903-17639	Q.D. YOKE ASSEMBLY	2
2	903-17525	44R CROSS & BEARING KIT	2
3	903-18208	YOKE & SHAFT (1.31 SQ.)	1
4	903-18271	GUARD REPAIR KIT (NOT SHOWN)	1
5	903-17455	SAFETY SIGN	1
6	903-18276	OUTER GUARD	2
7	903-18277	INNER GUARD	1
8	903-18247	SAFETY SIGN (NOT SHOWN)	1
9	903-18248	GUARD REPAIR KIT (NOT SHOWN)	1
10	903-18209	YOKE, TUBE & SLIP SLEEVE	1
	903-18207	GUARD SET	
	903-18198	JUMP PTO DRIVE SHAFT, COMPLETE	

## 1-3/8" PTO WWCV DRIVE SHAFT COMPONENTS



ITEM NO.	PART NUMBER	DESCRIPTION	QTY.
1	903-18106	SSL / AUTO-LOK REPAIR KIT	1
2	903-18334	WWCV AUTO-LOK YOKE ASSEMBLY	1
3	903-18328	AB8/AW24/CAT 6 80° EBL CROSS KIT	2
4	903-18329	WWCV CENTER HOUSING	1
5	903-18415	WWCV YOKE & SHAFT (1.69-20)	1
6	903-18248	GUARD REPAIR KIT	1
7	903-17455	SAFETY SIGN	1
8	903-18361	OUTER GUARD	1
9	903-18362	INNER GUARD	1
10	903-17456	SAFETY SIGN	1
11	903-18363	YOKE, TUBE & SLIP SLEEVE	1
12	903-17239	55E CROSS KIT	1
13	903-18364	YOKE	1
	903-18411	WWCV PTO DRIVE SHAFT, 1-3/8", COMPLETE	

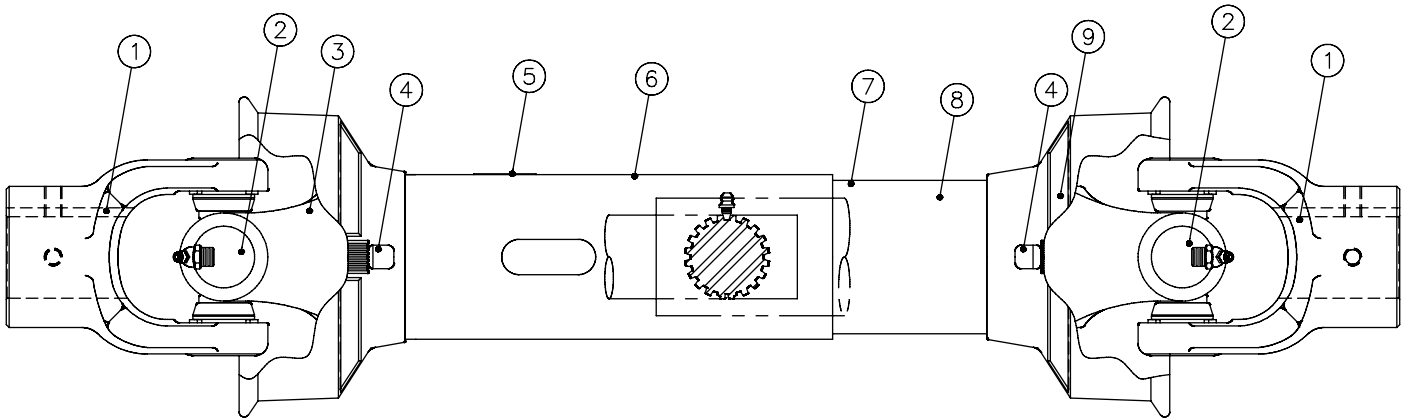
## 1-3/4" PTO WWCV DRIVE SHAFT COMPONENTS



ITEM NO.	PART NUMBER	DESCRIPTION	QTY.
1	903-17772	SSL / AUTO-LOK REPAIR KIT	1
2	903-18327	WWCV AUOT-LOK YOKE ASSEMBLY	1
3	903-18328	AB8/AW24/CAT 6 80° EBL CROSS & BEARING KIT	2
4	903-18329	WWCV CENTER HOUSING	1
5	903-18418	WWCV YOKE & SHAFT (1.69-20)	1
6	903-18248	GUARD REPAIR KIT	1
7	903-17455	SAFETY SIGN	1
8	903-18371	OUTER GUARD	1
9	903-18372	INNER GUARD	1
10	903-17456	SAFETY SIGN	1
11	903-18373	YOKE, TUBE & SLIP SLEEVE	1
12	903-17239	55E CROSS & BEARING KIT	1
13	903-18364	YOKE	1
	903-18412	WWCV PTO DRIVE SHAFT, 1-3/4", COMPLETE	

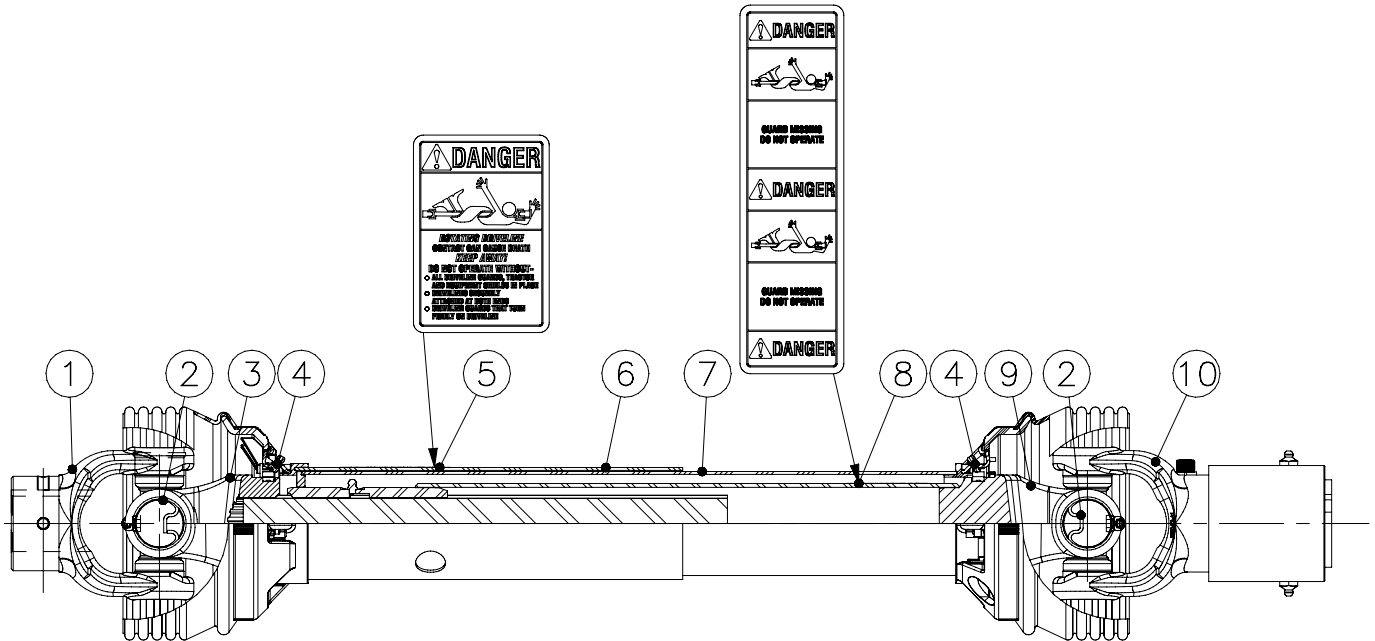


## WING DRIVE SHAFT COMPONENTS



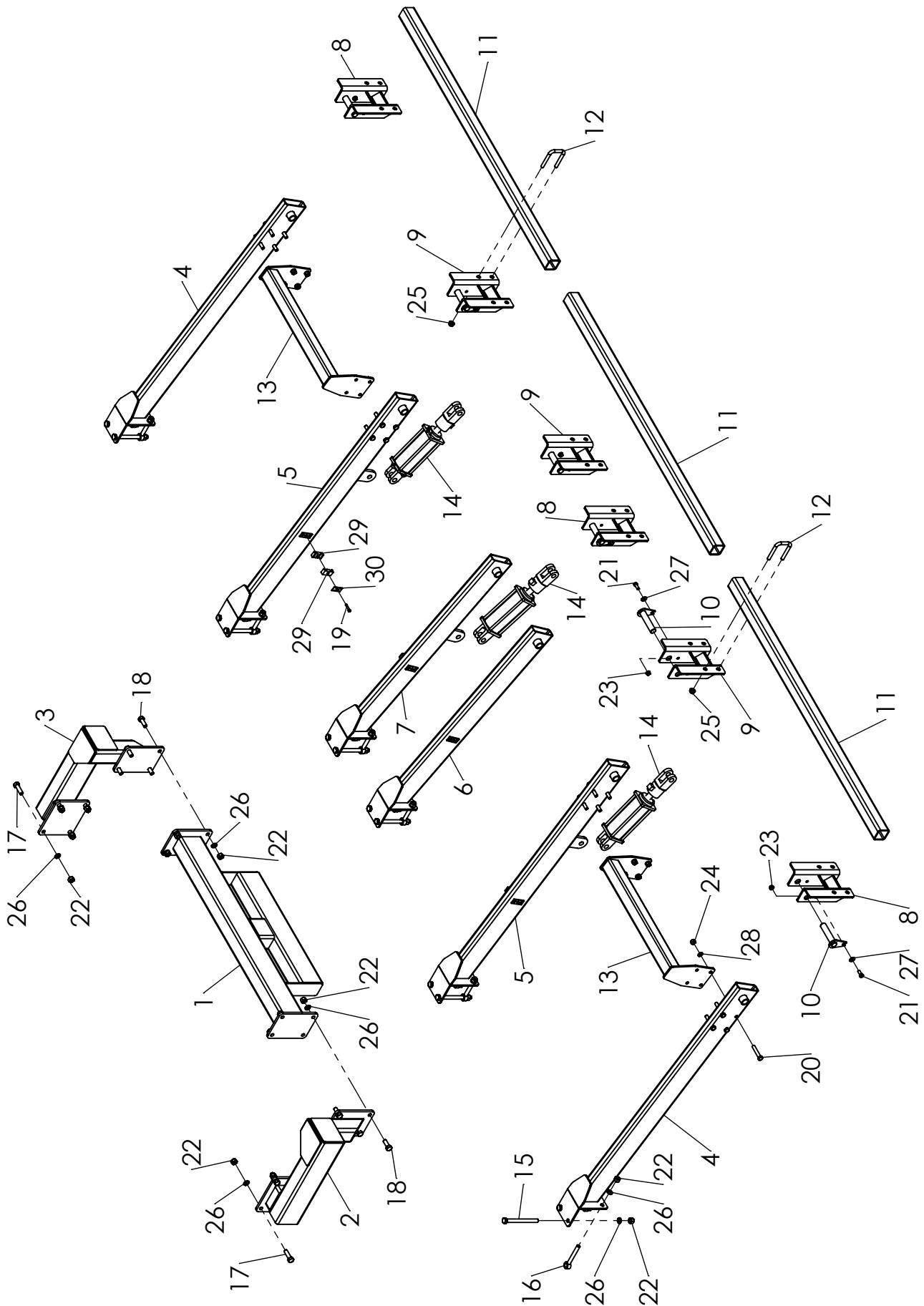
ITEM NO.	PART NUMBER	DESCRIPTION	QTY.
1	903-17639	YOKE	2
2	901-17525	44R CROSS & BEARING KIT	2
3	903-18079	YOKE & SHAFT (1.69-20)	1
4	903-17851	GUARD REPAIR KIT	2
5	903-18080	OUTER GUARD	1
6	903-18081	INNER GUARD	1
7	903-18082	YOKE, TUBE & SLIP SLEEVE	1
-	903-18055	WING DRIVE SHAFT, COMPLETE	-

# HITCH EXTENSION DRIVE SHAFT COMPONENTS



ITEM NO.	PART NUMBER	DESCRIPTION	QTY.
1	903-18364	YOKE	1
2	903-17239	55E CROSS & BEARING KIT	2
3	903-18378	YOKE & SHAFT (1.69-20)	1
4	903-17774	GUARD REPAIR KIT	2
5	903-17455	SAFETY SIGN	1
6	903-18379	OUTER GUARD	1
7	903-18380	INNER GUARD	1
8	903-17456	SAFETY SIGN	1
9	903-18381	YOKE, TUBE & SLIP SLEEVE	1
10	903-18382	OVERRUNNING CLUTCH ASM.	1
-	903-18308	HITCH EXTENSION DRIVE SHAFT, COMPLETE	-

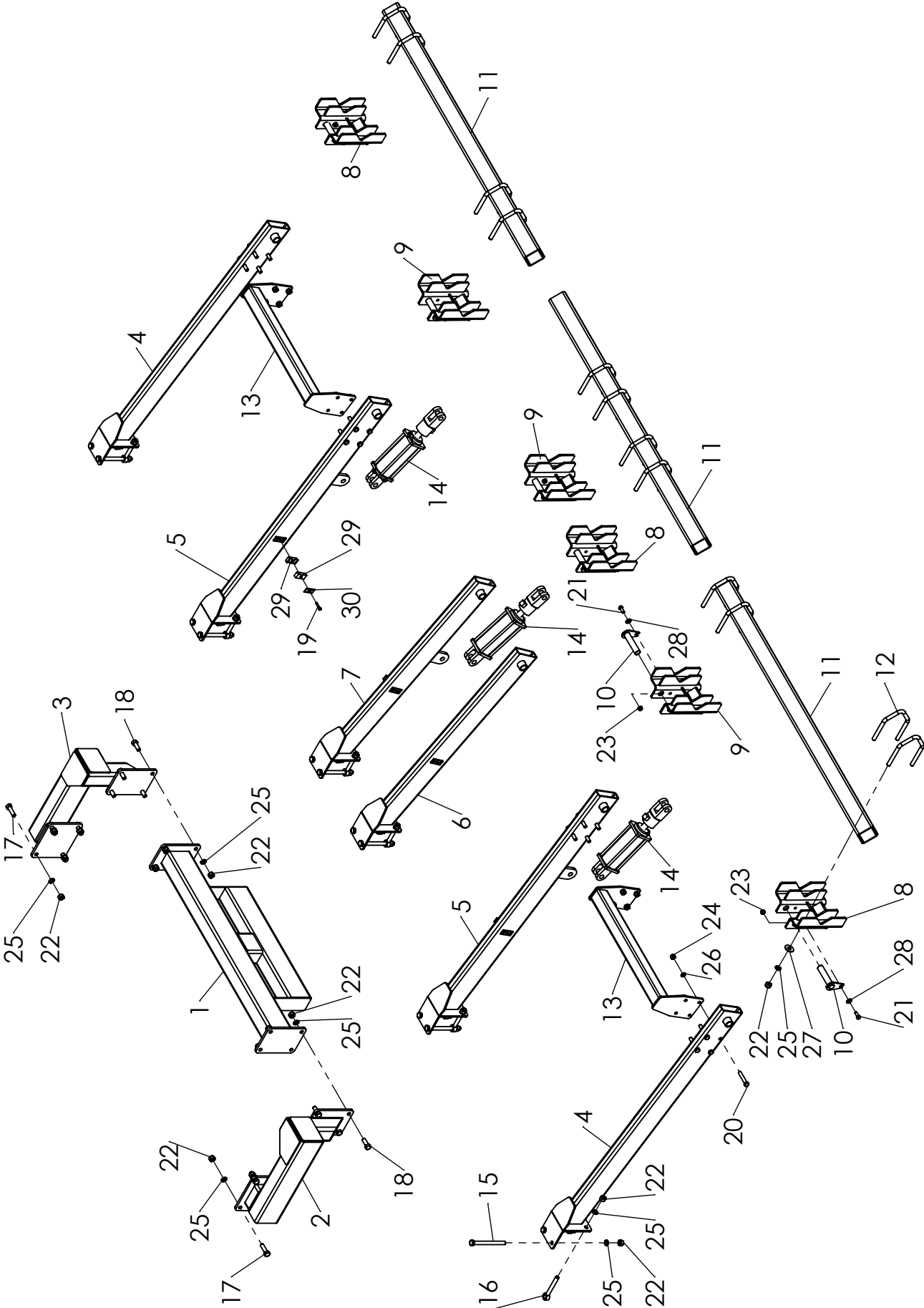
# SCALPER TOOLBAR COMPONENTS - STRAIGHT ARM



## SCALPER TOOLBAR COMPONENTS - STRAIGHT ARM

ITEM NO.	PART NUMBER	DESCRIPTION	QTY.
1	500-2-1234	CROSS TUBE	1
2	500-2-1231	MOUNT ARM (LH)	1
3	500-2-1233	MOUNT ARM (RH)	1
4	500-2-1437	WING SETBACK LONG ARM W/O CYLINDER EAR	2
5	500-2-1436	WING SETBACK LONG ARM W/ CYLINDER EAR	2
6	500-2-1435	CENTER SETBACK LONG ARM W/O CYLINDER EAR	1
7	500-2-1434	CENTER SETBACK LONG ARM W/ CYLINDER EAR	1
8	500-2-1440	SCALPER TUBE MOUNT W/O EAR - EXTENDED	3
9	500-2-1439	SCALPER TUBE MOUNT W/ EAR - EXTENDED	3
10	500-2-0684	1-1/4" PIN	6
11	500-3-2572	SCALPER TUBE	3
12	900-35026	U-BOLT, 5/8NC x 3 x 4-1/2	-
13	500-2-1144	WING SPREADER BAR	2
14	905-21400	CYLINDER, 3-1/2 x 8	3
15	900-01437	BOLT, 3/4 NC x 8-1/2	-
16	900-03463	EYE BOLT, 3/4NC x 6	-
17	900-01407	BOLT, 3/4 NC x 2-1/2	-
18	900-01403	BOLT, 3/4 NC x 2	-
19	900-02356	BOLT, 5/16 NC x 1-3/4	-
20	900-01357	BOLT, 5/8 NC x 3-1/2	-
21	900-01223	BOLT, 1/2 NC x 1-1/4	-
22	900-06015	NUT, 3/4 NC	-
23	900-06143	1/2 NC SPIRALOCK NUT	-
24	900-06013	NUT, 5/8 NC	-
25	900-06145	NUT, SPIRALOCK FLANGE 5/8 NC	-
26	900-11017	LOCK WASHER, 3/4	-
27	900-11035	WASHER, 1/2	-
28	900-11015	LOCK WASHER, 5/8	-
29	900-31069	CLAMP BODY - HOSE HOLDER	-
30	900-31068	COVER PLATE	-
-	500-2-1232	CENTER MOUNT KIT *INCLUDES: #1 - #3*	-

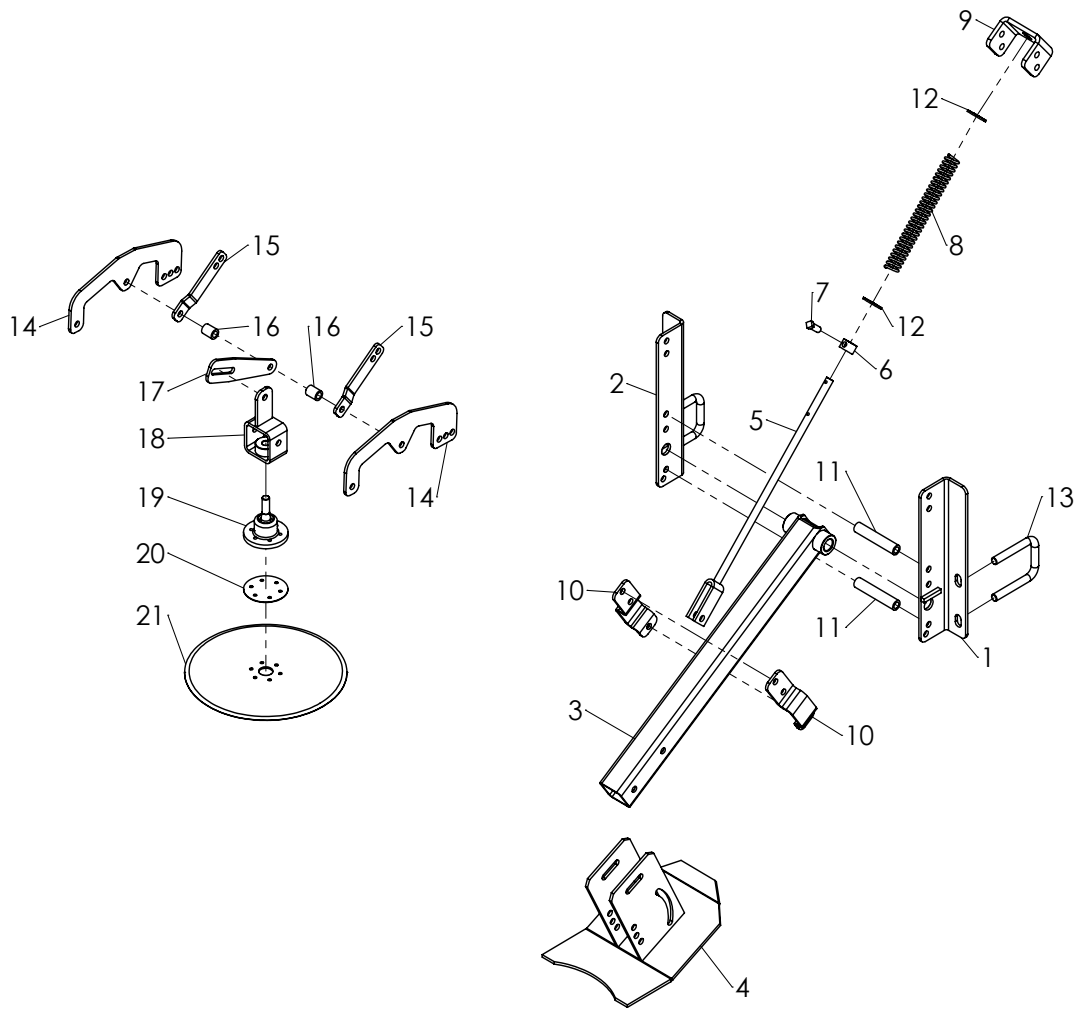
# SCALPER TOOLBAR COMPONENTS - PARALLEL LINK



## SCALPER TOOLBAR COMPONENTS - PARALLEL LINK

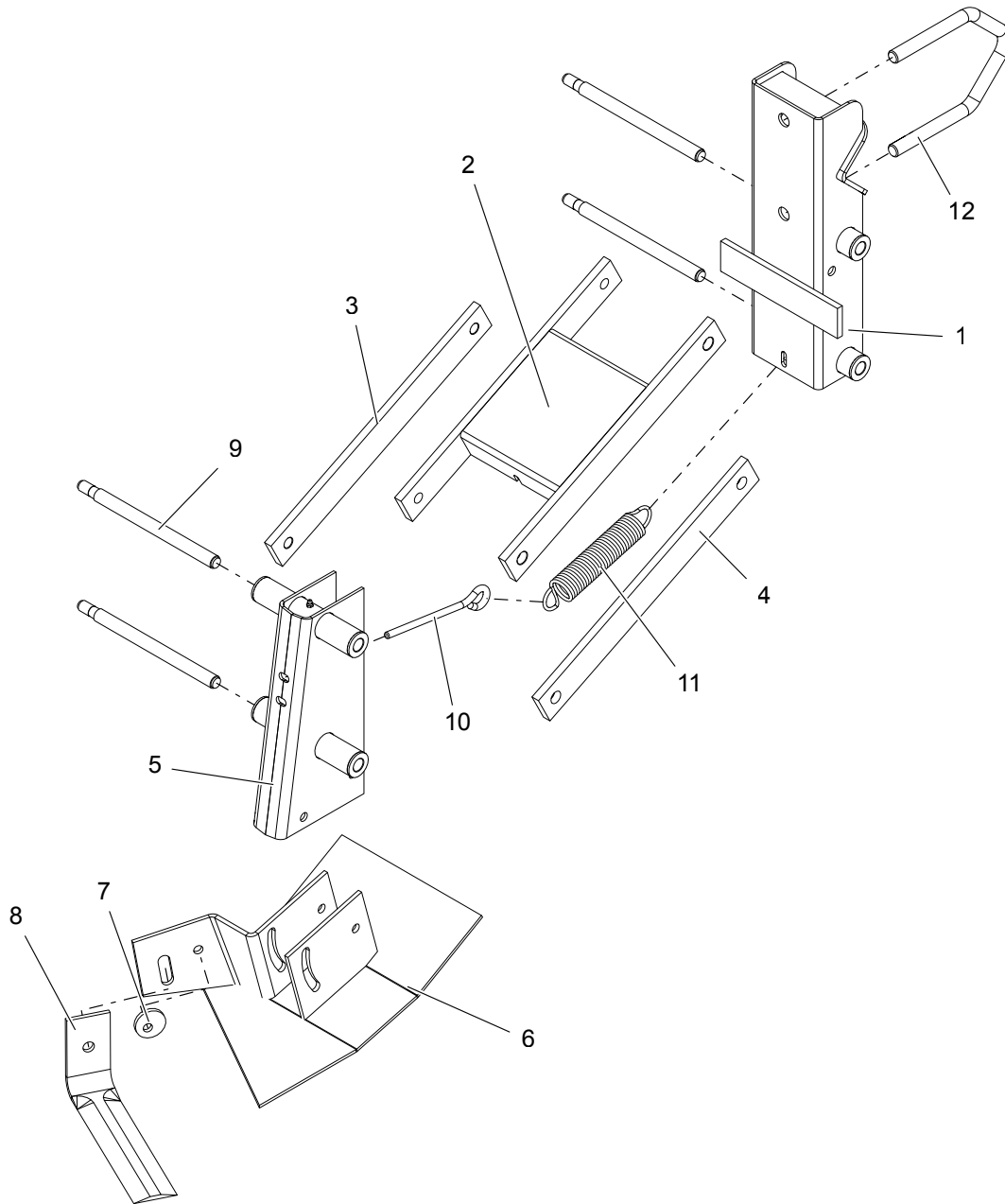
ITEM NO.	PART NUMBER	DESCRIPTION	QTY.
1	500-2-1234	CROSS TUBE	1
2	500-2-1231	MOUNT ARM (LH)	1
3	500-2-1233	MOUNT ARM (RH)	1
4	500-2-1437	WING SETBACK LONG ARM W/O CYLINDER EAR	2
5	500-2-1436	WING SETBACK LONG ARM W/ CYLINDER EAR	2
6	500-2-1435	CENTER SETBACK LONG ARM W/O CYLINDER EAR	1
7	500-2-1434	CENTER SETBACK LONG ARM W/ CYLINDER EAR	1
8	500-2-0942	SCALPER TUBE MOUNT W/O EAR	3
9	500-2-0941	SCALPER TUBE MOUNT W/ EAR	3
10	500-2-0684	1-1/4" PIN	6
11	500-3-2558	SCALPER TUBE	3
12	500-3-0635	A-BOLT, 3/4 NC X 4 X 4	-
13	500-2-1144	WING SPREADER BAR	2
14	905-21400	CYLINDER, 3-1/2 x 8	3
15	900-01437	BOLT, 3/4 NC x 8-1/2	-
16	900-03463	EYE BOLT, 3/4NC x 6	-
17	900-01407	BOLT, 3/4 NC x 2-1/2	-
18	900-01403	BOLT, 3/4 NC x 2	-
19	900-02356	BOLT, 5/16 NC x 1-3/4	-
20	900-01357	BOLT, 5/8 NC x 3-1/2	-
21	900-01223	BOLT, 1/2 NC x 1-1/4	-
22	900-06015	NUT, 3/4 NC	-
23	900-06143	1/2 NC SPIRALOCK NUT	-
24	900-06013	NUT, 5/8 NC	-
25	900-11017	LOCK WASHER, 3/4	-
26	900-11015	LOCK WASHER, 5/8	-
27	900-11038	WASHER, 3/4	-
28	900-11035	WASHER, 1/2	-
29	900-31069	CLAMP BODY - HOSE HOLDER	-
30	900-31068	COVER PLATE	-
-	500-2-1232	CENTER MOUNT KIT *INCLUDES: #1 - #3*	-

## CIRCULAR KNIFE SCALPER - STRAIGHT ARM



ITEM NO.	PART NUMBER	DESCRIPTION	QTY.
1	500-2-1438	MOUNT WELD (RH)	1
2	500-3-2948	MOUNT (LH)	1
3	500-2-1318	PIVOT TUBE WELD	1
4	500-2-1068	SCALPER SHOE	1
5	500-2-0072	LIFT ROD	1
6	500-3-0172	RETAINING COLLAR	1
7	900-16063	SET SCREW, 1/2 N x 1-1/4	1
8	500-3-0157	SPRING	1
9	500-3-1756	SPRING RETAINER	1
10	500-3-1757	LIFT ROD CLAMP	2
11	500-3-1561	MOUNT SPACER	2
12	900-11037	WASHER, 5/8	2
13	900-35026	U-BOLT, 5/8 NC x 3 x 4-1/2	2
14	500-3-2507	SHOE LINK BAR	2
15	500-3-2265	SHOE ADJUSTMENT ARM	2
16	500-3-1556	DISC SPACER	2
17	500-3-1557	DISC ADJUSTMENT ARM	1
18	500-2-1138	DISC MOUNT	1
19	905-09178	ROTARY DISC HUB	1
20	500-3-1940	DISC COVER	1
21	500-3-1582	ROTARY DISC	1

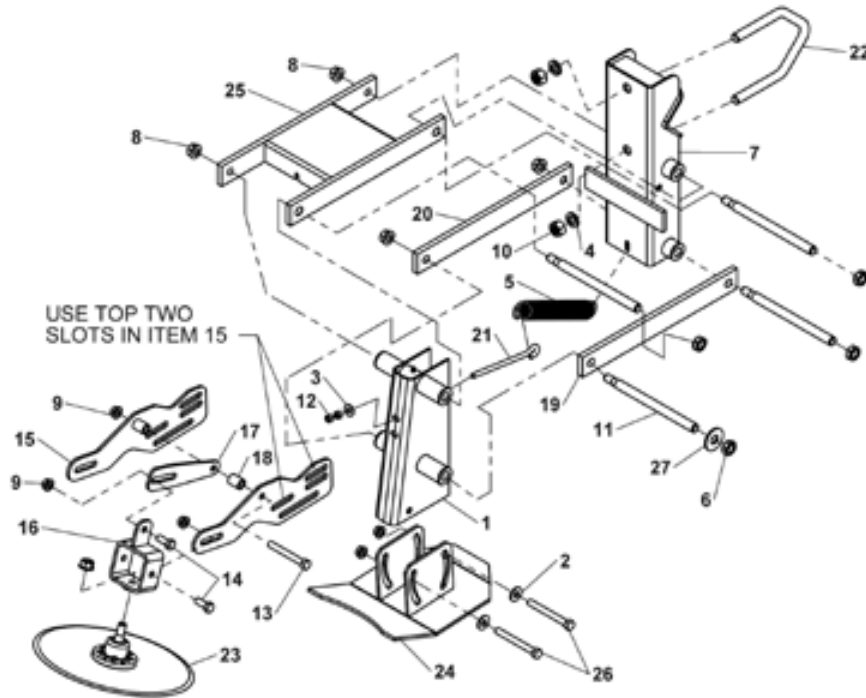
## STRAIGHT KNIFE SCALPER - PARALLEL ARM



ITEM NO.	PART NUMBER	DESCRIPTION	QTY.
1	500-2-0330	UPPER MOUNT	1
2	500-2-0518	"H" LINKAGE ARM	1
3	500-3-0991	LINKAGE ARM (LH)	1
4	500-3-0992	LINKAGE ARM (RH)	1
5	500-2-0338	LOWER SHOE MOUNT	1
6	500-2-0335	SHOE (LH)	1
7	500-2-0336	SHOE (RH)	1
8	500-3-0201	ECCENTRIC SPACER	1
9	500-3-0910	KNIFE SCALPER	1
10	200-3-2631	PIN	4
11	500-3-0675	EYE BOLT, 3.8 x 8	1
12	400-3-0263	EXTENSION SPRING	1
12	500-3-0635	A-BOLT, 3/4 NC x 4 x 4	1

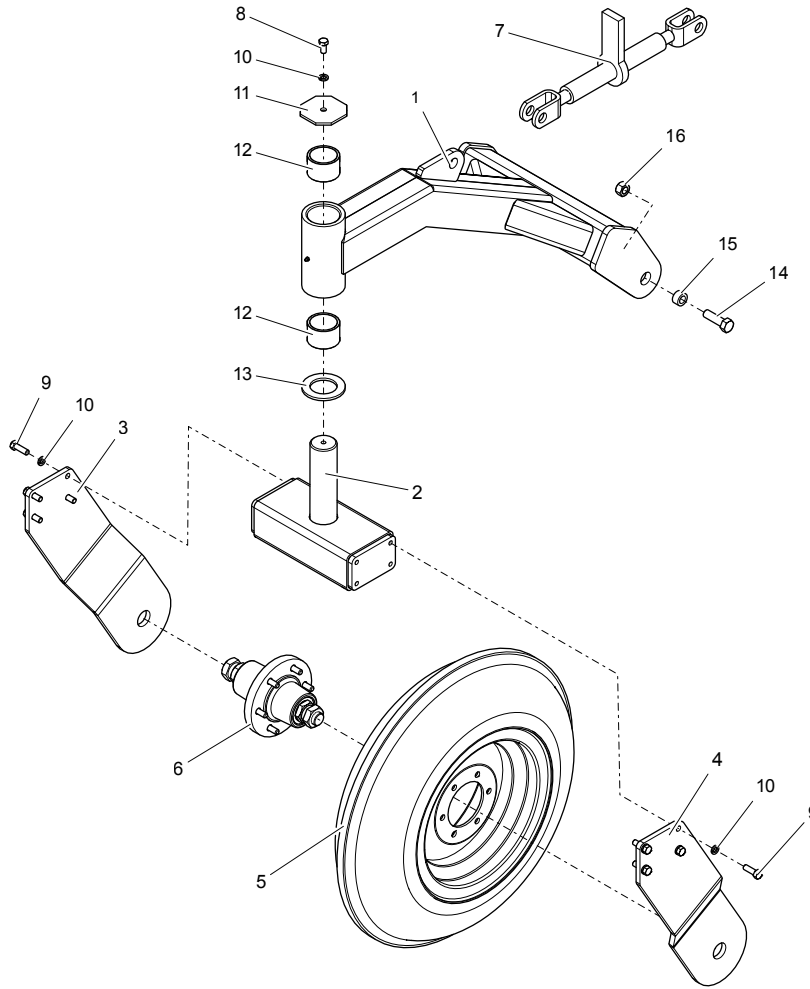


## CIRCULAR KNIFE SCALPER - PARALLEL ARM



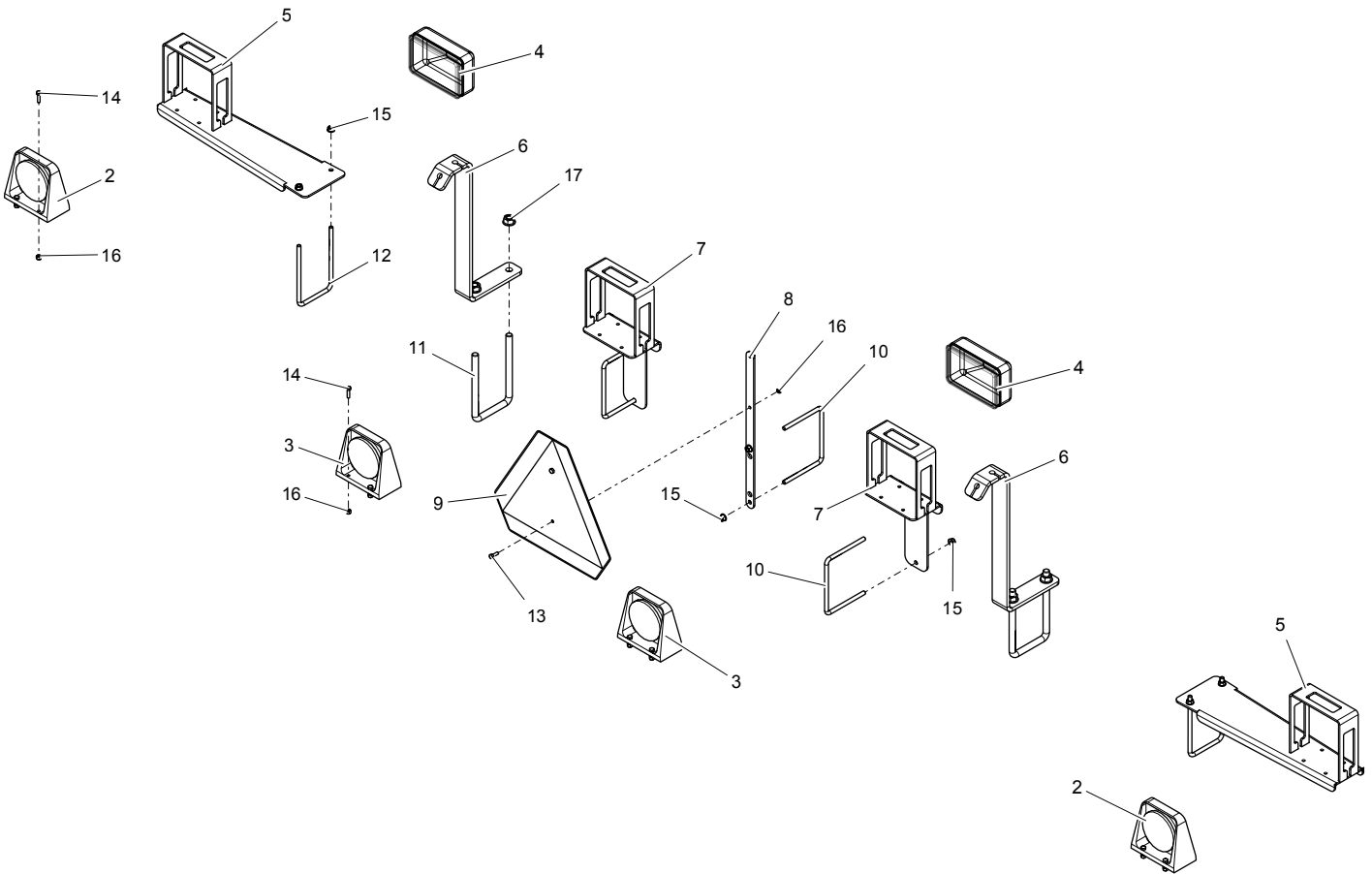
ITEM NO.	PART NUMBER	DESCRIPTION	QTY.
1	500-2-0338	UPRIGHT WELD	1
2	900-11035	1/2 FLAT WASHER, ZP	2
3	900-11033	3/8 FLAT WASHER, ZP	1
4	900-11017	3/4 LOCK WASHER	2
5	400-3-0263	SPRING, GM AND ALLOWBOOM	
6	900-06510	3/4 NC TOP LOCK NUT, ZP	4
7	500-2-0330	MOUNT WELD	1
8	900-06145	5/8 NC SPIRALOCK FLANGE NUT	5
9	900-06143	1/2 NC SPIRALOCK FLANGE NUT	6
10	900-06015	3/4 NC HEX NUT ZP	2
11	200-3-2631	PIN, PLATED	4
12	900-06005	3/8 NC HEX NUT, ZP	2
13	900-01245	1/2 NC X 4 HEX BOLT, GR5	1
14	900-01223	1/2 NC X 1-1/4 HEX BOLT	3
15	500-3-1563	PLATE, BRACKET, REAR TOP	2
16	500-2-0774	BRACKET, PIVOT	1
17	500-3-1557	STRAP, TOP REAR, ADJ.	1
18	500-3-1556	REAR SPACER TUBE	2
19	500-3-0992	BAR, 3/4 HOLES	1
20	500-3-0991	BAR, 5/8 HOLES	1
21	500-3-0675	3/8 EYE BOLT X 8" LONG	1
22	500-3-0635	A-BOLT, 3/4 X 4 X 4	1
23	500-2-0762	HUB ASSY, SCALPER	1
	500-3-1582	DISC	1
	901-09219	HUB ASSY	1
	901-09220	HUB REPAIR KIT	1
24	500-2-0704	SCALPER SHOE WELD	1
25	500-2-0518	H-WELD	1
26	900-01247	1/2 NC X 4-1/2 HEX BOLT GR5	2

## STABILIZER WHEEL COMPONENTS



ITEM NO.	PART NUMBER	DESCRIPTION	QTY.
1	500-2-1128	UPPER ARM	1
2	200-2-0689	CASTER PIVOT BASE	1
3	200-3-2621	SIDE PLATE, LH	1
4	200-3-2622	SIDE PLATE, RH	1
5	200-2-0988	TIRE & WHEEL ASSEMBLY, 600 X 16SL MONORIB	1
	905-09019	- TIRE, 600 X 16 SINGLE RIB IMP	
	905-09157	- RIM, 16 X 4.5E, 6 BOLT	
6	200-2-0928	HUB & SPINDLE ASSEMBLY (617) - SEE PAGE 67	1
7	905-23014	RATCHET JACK, HEAVY DUTY	1
8	900-01221	BOLT, HEX HEAD, 1/2 NC X 1, GR5 ZP	1
9	900-01225	BOLT, HEX HEAD, 1/2 NC X 1-1/2, GR5 ZP	8
10	900-11013	WASHER, LOCK 1/2	9
11	200-3-1219	RETAINER PLATE	1
12	200-3-1766	BUSHING, OILITE, CASTER PIVOT	2
13	200-3-1233	WASHER, OILITE	1
14	900-01407	BOLT, HEX HEAD 3/4 NC X 2-1/2, GR5 ZP	2
15	500-3-2399	BUSHING, STEEL	2
16	900-06015	NUT, 3/4 NC	2
	500-1-0290	STABILIZER WHEELS (PAIR)	

# LIGHT COMPONENTS






ITEM NO.	PART NUMBER	DESCRIPTION	QTY.
1	500-3-2196	WIRE HARNESS	1
2	904-01154	LAMP, AMBER	2
3	904-01155	LAMP, RED	2
4	500-3-1721	LIGHT, FIELD	2
5	500-2-0929	BRACKET, AMBER LAMP	2
6	500-3-1720	BRACKET, FIELD LIGHT	2
7	500-2-1245	BRACKET, RED LAMP	2
8	500-3-2091	MOUNNT, SMV	1
9	500-3-1696	SIGN, SMNV	1
10	900-35000	U-BOLT, 3/8 NC x 6 x 5	3
11	200-3-0017	U-BOLT, 5/8 NC x 4 x 7-1/4	2
12	900-35001	U-BOLT, 3/8 NC x 4 x 7	2
13	900-01005	BOLT, 1/4 NC x 3/4	2
14	900-01009	BOLT, 1/4 NC x 1	16
15	900-06139	SPIRALOCK NUT, 3/8 NC	10
16	900-06496	TOP LOCK NUT, 1/4 NC	18
17	900-06145	SPIRALOCK NUT, 5/8 NC	4

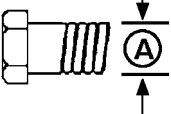
# BOLT TORQUE CHART

## SAE Series Torque Chart

Always tighten hardware to these values unless a different torque value or tightening procedure is listed for a specific application. Fasteners must always be replaced with the same grade as specified in the manual parts list.

Make sure fastener threads are clean and you properly start thread engagement.

SAE Bolt Head Identification		 SAE Grade 2 (No Dashes)		 SAE Grade 5 (3 Radial Dashes)		 SAE Grade 8 (6 Radial Dashes)	
Ⓐ Diameter (Inches)	Wrench Size	MARKING ON HEAD					
		SAE 2		SAE 5		SAE 8	
		ft./lb.	(Nm)	ft./lb.	(Nm)	ft./lb.	(Nm)
1/4"	7/16"	6	(8)	10	(13)	14	(18)
5/16"	1/2"	12	(17)	19	(26)	27	(37)
3/8"	9/16"	23	(31)	35	(47)	49	(67)
7/16"	5/8"	36	(48)	55	(75)	78	(106)
1/2"	3/4"	55	(75)	85	(115)	120	(163)
9/16"	13/16"	78	(106)	121	(164)	171	(232)
5/8"	15/16"	110	(149)	170	(230)	240	(325)
3/4"	1-1/8"	192	(261)	297	(403)	420	(569)
7/8"	1-5/16"	306	(416)	474	(642)	669	(907)
1"	1-1/2"	350	(475)	680	(925)	1020	(1383)
1-1/8"	1-11/16"	450	(610)	885	(1200)		
1-1/4"	1-7/8"	600	(815)	1255	(1700)		
1-3/8"	2-1/16"	675	(915)	1620	(2200)		
1-1/2"	2-1/4"	920	(1250)	2200	(2900)		



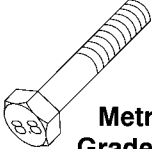
Bolt Diameter

## Metric Series Torque Chart

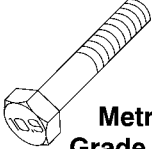
Use only metric tools on metric hardware. Always tighten hardware to these values unless a different torque value or tightening procedure is listed for a specific application. Fasteners must always be replaced with the same grade.

Make sure fastener threads are clean and you properly start thread engagement.

Ⓐ Diameter & Thread Pitch (Millimeters)	Wrench Size	COARSE THREAD				FINE THREAD				Ⓐ Diameter & Thread Pitch (Millimeters)	Metric Bolt Head Identification
		MARKING ON HEAD				MARKING ON HEAD					
		Metric 8.8		Metric 10.9		Metric 8.8		Metric 10.9			
		Nm	ft./lb.	Nm	ft./lb.	Nm	ft./lb.	Nm	ft./lb.		
6x1.0	10 mm	8	6	11	8	8	6	11	8	6x1.0	
8x1.25	13 mm	20	15	27	20	21	16	29	22	8x1.0	
10x1.5	16 mm	39	29	54	40	41	30	57	42	10x1.25	
12x1.75	18 mm	68	50	94	70	75	55	103	76	12x1.25	
14x2.0	21 mm	109	80	151	111	118	87	163	120	14x1.5	
16x2.0	24 mm	169	125	234	173	181	133	250	184	16x1.5	
18x2.5	27 mm	234	172	323	239	263	194	363	268	18x1.5	
20 x 2.5	30 mm	330	244	457	337	367	270	507	374	20x1.5	
22 x 2.5	34 mm	451	332	623	460	495	365	684	505	22 x 1.5	
24 x 3.0	36 mm	571	421	790	583	623	459	861	635	24 x 2.0	
30 x 3.0	46 mm	1175	867	1626	1199	1258	928	1740	1283	30 x 2.0	

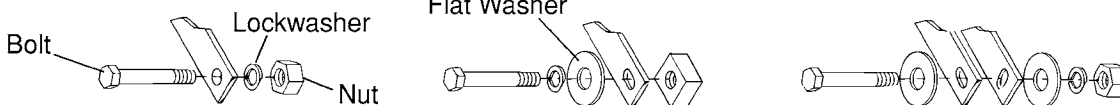


Metric Grade 8.8



Metric Grade 10.9

## Typical Washer Installations



8/9/00

# ABBREVIATIONS

AG .....	Agriculture	NC .....	National Course
ASAE .....	American Society of Agricultural Engineers	NF.....	National Fine
ATF.....	Automatic Transmission Fluid	NPSM.....	National Pipe Straight Mechanical
BSPP.....	British Standard Pipe Parallel	NPT .....	National Pipe Tapered
BSPTM.....	British Standard Pipe Tapered Male	NPT SWF.....	National Pipe Tapered Swivel Female
CV .....	Constant Velocity	Nm.....	Newton Meter
CCW .....	Counter-Clockwise	OSHA...	Occupational Safety and Health Administration
CW .....	Clockwise	P .....	Pitch
DIA.....	Diameter	PBY .....	Power Beyond
EP.....	Extreme Pressure	psi.....	Pounds per Square Inch
F .....	Female	PTO.....	Power Take Off
FB.....	Female O-Ring Boss	QD .....	Quick Disconnect
FJ .....	Female Boss	RH .....	Right Hand
FJX.....	Female Swivel JIC	ROPS.....	Roll Over Protection Structure
FP .....	Female Pipe	RPM .....	Revolutions Per Minute
ft./lb.....	Foot Pound	RT.....	Right
GA .....	Gauge	SAE .....	Society of Automotive Engineers
GR (5, etc.) .....	Grade (5, etc.)	SMV .....	Slow Moving Vehicle
HHCS.....	Hex Head Cap Screw	UNC .....	Unified Coarse
HT.....	Heat Treated	UNF .....	Unified Fine
in.....	Inch	UNS.....	Unified Special
JIC.....	Joint Industry Council 37° Flare	ZP.....	Zinc Plate
kg.....	Kilogram		
km/h .....	Kilometers Per Hour		
lb.....	Pound		
LH.....	Left Hand		
LT.....	Left		
in.....	Inches		
m .....	Meter		
mm .....	Millimeter		
M .....	Male		
MB.....	Male O-Ring Boss		
MJ.....	Male JIC		
MJX.....	Male Swivel JIC		
MP .....	Male Pipe		
MPa.....	Mega Pascal		
MPH .....	Miles Per Hour		
N.....	Newton		

# INDEX

## GENERAL

Abbreviations.....	86
Bolt Torque Chart .....	85
Check Lists .....	8
General Information .....	1
Introduction.....	Inside Front Cover
Product Warranty .....	Inside Back Cover
Replacement Part Warranty .....	88
Specifications .....	2
Table of Contents .....	1

## OPERATION ..... 15 - 28

Attaching to the Tractor .....	20 - 21
Break-In of the Defoliator .....	18
Defoliator Stored Position .....	28
Disconnecting from Tractor .....	22 - 23
Equipment Matching .....	18 - 20
CV Driveline Turning Limits .....	19
Drawbar with Clevis .....	19
Electrical System .....	19
Hydraulic System .....	19
Mount and Dismount Tractor .....	20
PTO .....	18
Tractor Ballast .....	20
Field Operation .....	25 - 26
Entering the Field .....	26
Field Performance .....	26
Starting Defoliator .....	26
Stopping Defoliator .....	26
Lowering Wings to Operating Position .....	24
Pre-Operation Check List .....	17
Principal Components .....	16
Raising Wings to Transport Position .....	23
Rear Steering (Optional) .....	27
Scalpels (Optional) .....	27 - 28
Transporting the Defoliator .....	28

## OPERATOR SIGN-OFF RECORD ..... 9

## OWNER SERVICE ..... 29 - 33

Blocking Method .....	29 - 30
Lubrication .....	30 - 31
Maintenance .....	32 - 33
Drive Belts .....	32
Flail Replacement .....	33

## PARTS INDEX ..... 35

## SAFETY..... 3

Check Lists .....	10
Decal Instructions.....	8-9
Maintenance.....	5-6
Operation.....	4-5
Operator Sign-Off Record.....	11
Preparation.....	3
Storage .....	6
Transporting .....	4

## SAFETY DEALS ..... 10 - 13

## SAFETY RULES ..... 3 - 7

Maintenance .....	6 - 7
Operation .....	5 - 6
Preparation .....	3 - 4
Storage .....	7
Training .....	3
Transporting .....	4 - 5

## TROUBLE SHOOTING ..... 34

# WARRANTY

Please Enter Information Below and Save For Future Reference.

Date Purchased: \_\_\_\_\_ From (Dealer): \_\_\_\_\_

Model Number: \_\_\_\_\_ Serial Number: \_\_\_\_\_

ALLOWAY STANDARD, d/b/a ALLOWAY, warrants this product to be free from defect in material and workmanship for TWELVE (12) MONTHS COMMENCING ON THE DATE OF DELIVERY OF THE PRODUCT TO THE ORIGINAL PURCHASER.

Under no circumstances will this Warranty apply in the event that the product, in the good faith opinion of ALLOWAY, has been subjected to improper operation, improper maintenance, misuse, or an accident. This Warranty does not apply in the event that the product has been materially modified or repaired by someone other than ALLOWAY, a ALLOWAY authorized dealer or distributor, and/or a ALLOWAY authorized service center; This Warranty does not cover normal wear or tear, or normal maintenance items. This Warranty also does not cover repairs made with parts other than those obtainable through ALLOWAY.

This Warranty is extended solely to the original purchaser of the product. Should the original purchaser sell or otherwise transfer this product to a third party, this Warranty does not transfer to the third party purchaser in any way. There are no third party beneficiaries of this Warranty.

ALLOWAY makes no warranty, express or implied, with respect to tires or other parts or accessories not manufactured by ALLOWAY. Their respective manufacturers, if any, provide warranties for these items, separately. ALLOWAY'S' obligation under this Warranty is limited to, at ALLOWAYS' option, the repair or replacement, free of charge, of the product if ALLOWAY, in its sole discretion, deems it to be defective or in noncompliance with this Warranty. The product must be returned to ALLOWAY with proof of purchase within thirty (30) days after such defect or noncompliance is discovered or should have been discovered, routed through the dealer and distributor from whom the purchase was made, transportation charges prepaid. ALLOWAY shall complete such repair or replacement within a reasonable time after ALLOWAY receives the product. THERE ARE NO OTHER REMEDIES UNDER THIS WARRANTY. THE REMEDY OF REPAIR OR REPLACEMENT IS THE SOLE AND EXCLUSIVE REMEDY UNDER THIS WARRANTY.

THERE ARE NO WARRANTIES, WHICH EXTEND BEYOND THE DESCRIPTION ON THE FACE OF THIS WARRANTY. ALLOWAY MAKES NO OTHER WARRANTY, EXPRESS OR IMPLIED, AND ALLOWAY SPECIFICALLY DISCLAIMS ANY IMPLIED WARRANTY OF MERCHANTABILITY AND/OR ANY IMPLIED WARRANTY OF FITNESS FOR A PARTICULAR PURPOSE.

ALLOWAY shall not be liable for any incidental or consequential losses, damages or expenses, arising directly or indirectly from the product, whether such claim is based upon breach of contract, breach of warranty, negligence, strict liability in tort or any other legal theory. Without limiting the generality of the foregoing. Alloway specifically disclaims any damages relating to (i) lost profits, business, revenues or goodwill; (ii) loss of crops; (iii) loss because of delay in harvesting; (iv) any expense or loss Incurred for labor, supplies, substitute machinery or rental; or (v) any other type of damage to property or economic loss.

This Warranty is subject to any existing conditions of supply, which may directly affect ALLOWAYS' ability to obtain materials or manufacture replacement parts.

No agent, representative, dealer, distributor, serviceperson, salesperson, or employee of any company; including without limitation, ALLOWAY, its authorized dealers, distributors, and service centers, is authorized to alter, modify, or enlarge this Warranty.

This Warranty is effective only if the warranty registration card is returned within ten (10) days.

Answers to any questions regarding warranty service and locations may be obtained by contacting:

Alloway  
4230 14<sup>th</sup> Ave.NW  
Fargo, North Dakota 58102  
701-356-4983



## WARRANTY

ALLOWAY STANDARD, d/b/a ALLOWAY, warrants this product to be free from defect in material and workmanship for a period of One (1) year, ninety (90) days for Service Parts, from the date of delivery of the product to the original purchaser.

Under no circumstances will this Warranty apply in the event that the product, in the good faith opinion of ALLOWAY, has been subjected to improper operation, improper maintenance, misuse, or an accident. This Warranty does not cover normal wear or tear, or normal maintenance items.

This Warranty is extended solely to the original purchaser of the product. Should the original purchaser sell or otherwise transfer this product to a third party, this Warranty does not transfer to the third party purchaser in any way. There are no third party beneficiaries of this Warranty.

ALLOWAY'S' obligation under this Warranty is limited to, at ALLOWAY'S option, the repair or replacement, free of charge, of the product if ALLOWAY, in its sole discretion, deems it, to be defective or in noncompliance with this Warranty. The product must be returned to ALLOWAY with proof of purchase within thirty (30) days after such defect or noncompliance is discovered or should have been discovered, routed through the dealer and distributor from whom the purchase was made, transportation charges prepaid. ALLOWAY shall complete such repair or replacement within a reasonable time after ALLOWAY receives the product. THERE ARE NO OTHER REMEDIES UNDER THIS WARRANTY. THE REMEDY OF REPAIR OR REPLACEMENT IS THE SOLE AND EXCLUSIVE REMEDY UNDER THIS WARRANTY.

THERE ARE NO WARRANTIES WHICH EXTEND BEYOND THE DESCRIPTION ON THE FACE OF THIS WARRANTY. ALLOWAY MAKES NO OTHER WARRANTY, EXPRESS OR IMPLIED, AND ALLOWAY SPECIFICALLY DISCLAIMS ANY IMPLIED WARRANTY OF MERCHANTABILITY AND/OR ANY IMPLIED WARRANTY OF FITNESS FOR A PARTICULAR PURPOSE.

ALLOWAY shall not be liable for any incidental or consequential losses, damages or expenses, arising directly or indirectly from the product, whether such claim is based upon breach of contract, breach, of warranty, negligence, strict liability in tort or any other legal theory. Without limiting the generality of the foregoing, Alloway specifically disclaims any damages relating to (i) lost profits, business, revenues or goodwill; (ii) loss of crops; (iii) loss because of delay in harvesting; (iv) any expense or loss incurred for labor, supplies, substitute machinery or rental; or (v) any other type of damage to property or economic loss.

This Warranty is subject to any existing conditions of supply, which may directly affect ALLOWAYS' ability to obtain materials or manufacture replacement parts.

No agent, representative, dealer, distributor, service person, salesperson, or employee of any company, including without limitation, ALLOWAY, Its authorized dealers, distributors, and service centers, IS authorized to alter, modify, or enlarge this Warranty.

Answers to any questions regarding warranty service and locations may be obtained by contacting:

Alloway  
4230 14<sup>th</sup> Ave.NW  
Fargo, North Dakota 58102  
701-356-4983





**PART NUMBER**  
**500-5-0013**



*Quality • Innovation*

Alloway Standard Industries  
4230 14th Avenue NW  
Fargo, North Dakota 58102

Local/Intl: 1-701-356-4983  
Toll Free: 1-877-275-8714  
Fax: 1-701-356-4985